

44

**D 4506** 7876 / 1 7868 / 1

MANITOU (4006) 7542 / 0001

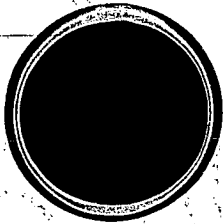

0500 0694

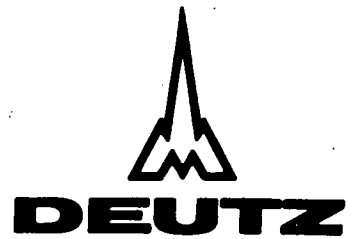

# D 45 06

Gültig ab Traktor-Nr.

Effective from tractor No.

7876/1

Valable à partir du tracteur No.

7868/1

Válida a partir tractor No.

**Ersatzteil- u. Nummernliste**  
**Spare Parts / Nos. List**  
**Lista de références**  
**constructives**  
**et de pièces de rechange**  
**Lista de Nos.**  
**de piezas y de repuestos**

500 0672 1003-99



**Hiermit wird die Ersatzteil-Nummernliste  
500 0637 1003-99 ungültig.**

**Spare parts number list 500 0637 1003-99  
becomes herewith null and void.**

**La liste des numéros de pièces  
500 0637 1003-99 est annulée par la présente.**

**Por la presente queda sin efecto la Lista  
de Nos. de piezas 500 0637 1003-99.**

**Ersatzteil- u. Nummernliste  
Spare Parts/Nos. List  
Lista de références constructives  
et de pièces de rechange  
Lista de Nos. de piezas y  
de repuestos**

500 0672 1003-99

Diese Druckschrift ist für unseren Ersatzteildienst bestimmt und darf weder ganz noch auszugsweise weitergegeben oder zu anderen Zwecken, als denen sie dem Empfänger anvertraut wurde, benutzt werden.

This list is intended to be used solely for our Spare Parts Service and may not be distributed in part or whole, nor used for purposes other than for which it was issued to the receiver.

Cette brochure est destinée à notre service de fourniture des pièces de rechange. Son détenteur ne devra en aucun cas permettre à des tiers d'en prendre connaissance même partiellement ou l'utiliser à des fins autres que celles pour lesquelles elle lui a été confiée.

Esta lista está destinada a nuestro servicio de suministro de repuestos, no debiendo transmitirla su tenedor, total o parcialmente a terceros, ni emplearla en otros fines que para los que le ha sido confiada.

**Die Druckschrift bleibt unser Eigentum.**

**This book remains our property.**

**Cette brochure reste notre propriété.**

**Esta lista sigue siendo propiedad nuestra.**

**Klöckner-Humboldt-Deutz  
Aktiengesellschaft**



Traktor      Tracteur

Tractor      Tractor

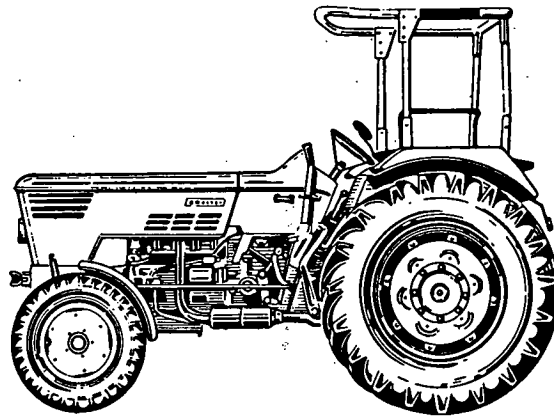

# D 45 06

Gültig ab Traktor-Nr.

Effective from tractor No.      7876/1

Valable à partir du tracteur No.      7868/1

Válida a partir tractor No.

Ersatzteil- u. -Nummernliste

Spare Parts/Nos. List

Lista de referéncias constructives  
et de pièces de rechange

Lista de Nos. de piezas y de repuestos

500 0672 1003-99

Klöckner-Humboldt-Deutz AG



**KHD**

> = Bis Traktor No. bzw.  
Getriebe No. bzw.  
Achsen No. bzw.  
Kraftheber No.

< = Ab Traktor No. bzw.  
Getriebe No. bzw.  
Achsen No. bzw.  
Kraftheber No.

> = To tractor No. resp.  
transmission No. resp.  
driven axle No. resp.  
hydraulic lift No.

< = From tractor No. resp.  
transmission No. resp.  
driven axle No. resp.  
hydraulic lift No.

> = Jusque tracteur no. ou  
transmission no. ou  
essieux no. ou  
verin hydraulique no.

< = A partir de tracteur no. ou  
transmission no. ou  
essieux no. ou  
verin hydraulique no.

> = hasta tractor No. resp.  
transmisión No. resp.  
eje motriz No. resp.  
elevador hidraulico No.

< = desde tractor No. resp.  
transmisión No. resp.  
eje motriz No. resp.  
elevador hidraulico No.

ETK DEUTSCH  
01 TEIL VORDRINGLICH AUF LAGER HALTEN

ETK ENGLISH  
01 STOCK AS PRIORITY PART

ETK FRANCAIS  
01 Pièce a tenir en stock en première urgence

ETK ESPANOL  
01 PIEZA A MANTENER CON PRIORIDAD EN STOCK

Nolizen

---

Dieser Hinweis ist nur für den Traktoren-Kunden bestimmt.

**Bei Ersatzteilbestellungen**

erwarten Sie unsere richtige Lieferung; dazu brauchen wir von Ihnen folgende Angaben:

1. **Typenbezeichnung** (z.B. D 100 06)
2. **Variantenbezeichnung** (z.B. NULD)
3. **Traktor- u. Motornummer**
4. **Nummer der Ersatzteil-Nummernliste** (z.B. 580 1213)
5. **Seite**
6. **Bild-Nummer des gewünschten Teiles, wie in der Tafel abgebildet**
7. **Stückzahl des gewünschten Teiles**
8. **Benennung des gewünschten Teiles**

**Bestellbeispiel**

Brieflich:

Für Traktor D 100 06/NULD

Traktor-Nr. 7859/413 Motor-Nr. 8 775 493

Ersatzteil-Nummernliste 580 1213, Seite 11, Bild-Nr. 41

bitte 1 Kolben



Ihre Ersatzteilbestellung richten Sie bitte an:

Ihren zuständigen Vertragshändler.

This note refers to tractor customers only.

**With regard to spare parts orders,**

you expect us to ensure correct supply; for this purpose, please quote the following

1. **type designation** (e.g. D 100 06)
2. **variant designation** (e.g. NULD)
3. **tractor No. and engine No.**
4. **No. of spare part numbers list** (e.g. 580 1213)
5. **page**
6. **Fig. No. identifying the part requested, as shown in the illustration**
7. **quantity of the part requested**
8. **denomination of the part requested**

**Example for ordering spare parts**

By letter:

For tractor D 100 06 / NULD

tractor No. 7859/413 engine No. 8 775 493

spare part numbers list 580 1213, page 11, Fig. No. 41

1 piston please

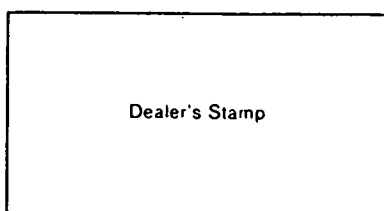

Please address your spare parts order to:

Our representation competent for you.

Cette remarque ne concerne que les clients de tracteurs.

**Pour les commandes de pièces de rechange**

vous attendez notre livraison correcte; pour cela nous avons besoin des renseignements suivants:

1. **Désignation du type** (par exemple D 100 06)
2. **Désignation de la variante** (par exemple NULD)
3. **Numéros de tracteur et de moteur**
4. **Numéro du catalogue de pièces de rechange** (par exemple 580 1213)
5. **Page**
6. **Numéro de figure de la pièce souhaitée, telle que représentée dans la planche**
7. **Quantités de pièces souhaitées**
8. **Désignation de la pièce souhaitées**

**Exemple de commande**

Par lettre:

pour tracteur D 100 06 / NULD

tracteur n° 7859/413 moteur n° 8 775 493

catalogue de numéros de pièces 580 1213, page 11, fig. 41

1 piston S.V.P

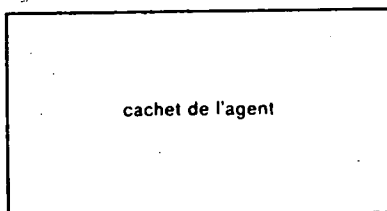

cachet de l'agent

**Veillez adresser votre commande de pièces de rechange à:**

notre représentation compétente pour vous.

Esta nota está destinada exclusivamente al usuario del tractor.

**Al pedir repuestos**

esperan Uds. un correcto suministro por parte de nosotros, a cuyo objeto necesitamos que Uds. nos indiquen los siguientes datos:

1. **Denominación de tipo** (p. ej D 100 06)
2. **Denominación de la variante** (p. ej. NULD)
3. **Nos. del tractor y del motor**
4. **No. de la lista de Nos. de repuestos** (p. ej. 580 1213)
5. **No. de la página correspondiente**
6. **Fig. No. de la pieza deseada, según representación en el grabado**
7. **Cantidad de la pieza deseada**
8. **Denominación de la pieza deseada**

**Ejemplo para un pedido:**

(por escrito)

Para tractor D 100 06 / NULD

tractor No. 7859/413, motor No. 8 775 493

lista de Nos. de repuestos 580 1213, página 11, Fig. No. 41

solicitamos 1 émbolo

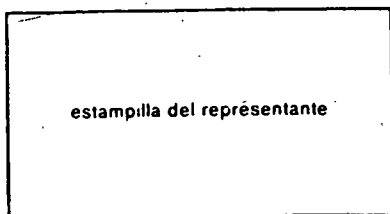

estampilla del representante

**Rogamos dirijan sus pedidos por repuestos a:**

nuestra representación competente para Vds.



## Kurzzeichen in der Spalte "Stückzahl"

- DS = Dichtungssatz  
Handelt es sich bei der in Spalte 23 angegebenen Nummer um die Teilenummer eines Dichtungssatzes, so wird linksbündig "DS" eingetragen.
- IP = Informationsposition  
Ist ein Teil ungültig, oder wird es als Ersatzteil nicht geliefert, die Teilenummer jedoch zur Information in Spalte 23 angegeben, so wird linksbündig "IP" eingetragen.
- MTR = Meterware  
Wird in Spalte 23 nicht die Teilenummer des dargestellten Teiles, sondern die Halbzeugteilenummer der Meterware (z.B. bei Schläuchen) angegeben, so wird "MTR" eingetragen.
- NB = Nach Bedarf  
Kann die erforderliche Stückzahl nicht angegeben werden, z.B. bei Übermaßstufen, so wird linksbündig "NB" eingetragen.
- RS = Reparatursatz  
Handelt es sich bei der in Spalte 23 angegebenen Nummer um die Teilenummer eines Reparatursatzes, so wird linksbündig "RS" eingetragen.
- SP = Sammelpackung  
Handelt es sich bei der in Spalte 23 angegebenen Nummer um die Teilenummer einer Sammelpackung, so wird linksbündig "SP" eingetragen.
- SZ = Satz  
Handelt es sich bei der in Spalte 23 angegebenen Nummer um die Teilenummer eines ganzen Satzes z.B. Ausgleichscheiben, so wird linksbündig "SZ" eingetragen.
- TN = Teilenummern-Listen-Blatt  
Ist unter einer Bild-Nummer eine Komplettierung dargestellt, die auf einem eigenen Teilenummern-Listen-Blatt (Ersatzteil-Nummernlisten-Blatt) aufgegliedert ist, so wird linksbündig "TN" eingetragen.

CODES IN THE COLUMN "STÜCKZAHL"/"QUANTITY"

- DS = Dichtungssatz/Set of gaskets  
If the number quoted in the column "Teile-No." is the part number of a set of gaskets, "DS" will be entered at the left of the column.
- IP = Informationsposition/Information item  
If a part is obsolete or if it is not delivered as spare parts but the part number is quoted in the column "Teile-No." for information, "IP" will be entered at the left of the column.
- MTR = Meterware/Goods by the metre  
If the column "Teile-No." does not include the part number of the illustrated part but the part number of the semi-finished goods by the metre (e.g. in the case of hoses), "MTR" will be entered.
- NB = Nach Bedarf/According to requirement  
If the required quantity cannot be indicated, e.g. in the case of oversizes, "NB" will be entered at the left.
- RS = Reparatursatz/Repair kit  
If the number quoted in the column "Teile-No." is the part number of a repair kit, "RS" will be entered at the left.
- SP = Sammelpackung/Collective package  
If the part number quoted in the column "Teile-No." is the part number of a collective package, "SP" will be entered at the left.
- SZ = Satz/Set  
If the number quoted in the column "Teile-No." is the part number of a complete set, e.g. shims, "SZ" will be entered at the left.
- TN = Teilenummern-Listen-Blatt/Part Numbers List Sheet  
If, under a figure number, a complete sub-assembly is illustrated, which is itemized on a separate part numbers list sheet (spare parts numbers list sheet). "TN" will be entered at the left.

Abréviations dans la colonne " Stückzahl ".

---

- DS = Jeu de joints  
Si le numéro mentionné dans la colonne " Teile Nr." est le no. de fabrication d'un jeu de joints, l'abréviation "DS" est inscrite à gauche.
- IP = Poste d'information  
Si une pièce est annulée, ou n'est pas livrable comme pièce de rechange, le no. de fabrication est indiqué dans la colonne "Teile Nr." à titre d'information. L'abréviation à gauche est alors IP.
- MTR = Articles au mètre  
Si la colonne "Teile Nr." ne mentionne pas le no. de fabrication de la pièce représentée, mais bien le no. de fabrication de l'article semi-fini au mètre (par ex. cas des flexibles) l'abréviation à gauche est MTR.
- NB = Selon besoin  
Si le nombre de pièces nécessaires ne peut être donné par ex. dans le cas de cote réparation, l'abréviation à gauche est NB.
- RS = Ensemble de réparation  
Si le numéro indiqué dans la colonne "Teile Nr." est le no. de fabrication d'un ensemble de réparation, l'abréviation à gauche est RS.
- SP = Lot de pièces  
Si le numéro indiqué dans la colonne "Teile Nr." est le numéro de fabrication d'un lot de pièces, l'abréviation à gauche est SP.
- SZ = Jeu  
Si le numéro indiqué dans la colonne "Teile Nr." est le numéro de fabrication d'un jeu complet, par ex. rondelles d'épaisseur, l'abréviation à gauche est SZ.
- TN = Page de liste de numéros de fabrication  
Si un sous-ensemble est représenté sous un no. de figure dont le détail est donné à part sur une page de la liste des numéros de fabrication (liste des numéros de pièces de rechange) l'abréviation à gauche est TN.

## Abreviaciones en la columna "Cantidad"

---

- DS = Juego de juntas  
Si se trata en el número indicado en la columna "No. de pieza" del número de pieza correspondiente a un juego de juntas, se registra "DS" en la columna "Cantidad", a la izquierda.
- IP = Posición informativa  
Si una pieza no corresponde o no se suministra más como repuesto, indicándose a título informativo su número de pieza en la columna "No. de pieza", se registra "IP" en la columna "Cantidad", a la izquierda.
- MTR = Material por metros lineares  
Si no se indica en la columna "No. de pieza" el número respectivo de la pieza representada, sino el del semiproducto correspondiente al material en metros (p.ej. al tratarse de mangueras), se registra "MTR"
- NB = Según necesidad  
Si no es posible indicar la cantidad necesaria, p.ej. en el caso de medidas de desgaste, se registra "NB" en la columna "Cantidad", a la izquierda.
- RS = Lote para reparaciones  
Si se trata en el número indicado en la columna "No. de pieza" del número de pieza de un lote para reparaciones, se registra "RS" en la columna "Cantidad", a la izquierda.
- SP = Paquete colectivo  
Si se trata en el número indicado en la columna "No. de pieza" del número de pieza para un paquete colectivo, se registra "SP" en la columna "Cantidad", a la izquierda.
- SZ = Juego  
Si se trata en el número indicado en la columna "No. de pieza" del número de pieza correspondiente a un juego completo, p.ej. arandelas de compensación, se registra "SZ" en la columna "Cantidad", a la izquierda.
- TN = Hoja de lista de Nos. de pieza  
Si bajo un No. de fig. queda representada una completación, desglosada por separado en una hoja de lista de Nos. de pieza (hoja de lista de Nos. de repuestos), se registra "TN" en la columna "Cantidad", a la izquierda.

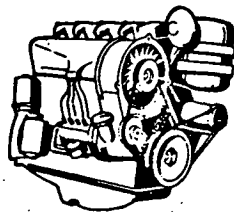

Baugruppen - Verzeichnis  
Index of Construction Groups  
Index des Groupes de Construction  
Indice de los Grupos de Construcción



Baugruppe: Constr. Group: Groupe/Grupo Constr.:

S./P.

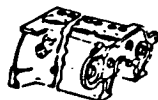

|           |   |    |
|-----------|---|----|
| <b>01</b> | Kurbelgehäuse-Oberteil<br>Crankcase<br>Bâti-cylindres<br>Bloque motor   | 34 |
| <b>01</b> | Zwischenradlagerung<br>Idler gear bearing<br>Tourillon de pignon intermédiaire<br>Soporte para rueda intermedia   | 36 |
| <b>01</b> | Vorderer Deckel<br>Front cover<br>Couvercle avant<br>Tapa delantera   | 37 |
| <b>01</b> | Befestigungsteile zum vorderen Deckel<br>Fastening parts for front cover<br>Pièces de fixation pour couvercle avant<br>Partes de fijación para tapa delantera       | 38 |
| <b>01</b> | Deckel mit Spannrolle<br>Cover with idler pulley<br>Couvercle avec galet tendeur<br>Tapa con polea tensora  |    |
| <b>01</b> | Verschluss für Nockenwellenantrieb<br>Camshaft drive cover<br>Pièces obturatrices pour arbre à cames<br>Cierre para accionamiento del árbol de levas                | 39 |
| <b>01</b> | Verschlussdeckel für Spritzversteller<br>Cover for advance/retard unit<br>Couvercle pour avance automatique<br>Tapa de cierre para graduador de avance de inyección | 40 |
| <b>01</b> | Deckel<br>Cover<br>Couvercle<br>Tapa  | 41 |
| <b>01</b> | Spritzdüse<br>Spray nozzle<br>Pulvérisateur<br>Tobera de dispersión   |    |
| <b>01</b> | Entlüftungsrohr<br>Vent pipe<br>Tuyau de désaération<br>Tubo de purga de aire   | 42 |
| <b>01</b> | Motorenentlüftung<br>Engine breather<br>Évent du moteur<br>Ventilación del motor  |    |
| <b>01</b> | Öleinfüllung<br>Oil filler neck<br>Tubulure de remplissage d'huile<br>Tubuladura de llenado   |    |
| <b>01</b> | Öleinfüllverschluss<br>Oil filler cap<br>Couvercle de cheminée de remplissage d'huile<br>Tapón de llenado de aceite   | 43 |
| <b>01</b> | Ölmeßstab<br>Oil dipstick<br>Jauge de niveau d'huile<br>Varilla de sondeo para nivel de aceite  | 44 |





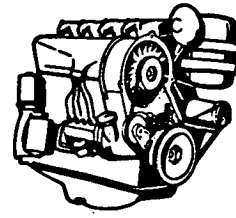

Baugruppen - Verzeichnis  
 Index of Construction Groups  
 Index des Groupes de Construction  
 Indice de los Grupos de Construcción



Baugruppe: Constr. Group: Groupe/Grupo Constr.:





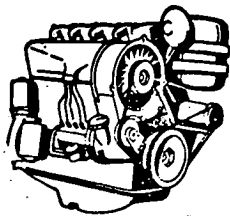

S./P.

|   |   |    |
|---|---|----|
|    | <b>01</b> Verschluss-<br>Locking parts<br>Pièces de fermeture<br>Partes de cierre   | 45 |
|   | <b>01</b> Ölmeßvorrichtung<br>Oil gauge fitting<br>Dispositif de mesure du niveau d'huile<br>Dispositivo de medición de nivel de aceite             |    |
|   |   |    |
|    | <b>02</b> Ölwanne<br>Oil pan<br>Carter d'huile<br>Sumidero de aceite  | 46 |
|   | <b>02</b> Ölwanne - Allrad<br>Oil pan - Four Wheel Drive<br>Carter d'huile - Toutes roues motrices<br>Sumidero de aceite - Traccion en las 4 ruedas | 47 |
|   | <b>02</b> Ölablaß<br>Oil drain<br>Bouchon de vidange d'huile<br>Sistema de vaciado de aceite  |    |
|   | <b>02</b> Öleinfüllung<br>Oil filler neck<br>Tubulure de remplissage d'huile<br>Tubuladura de llenado   |    |
|   | <b>02</b> Ölmeßstab<br>Oil dipstick<br>Jauge de niveau d'huile<br>Varilla de sondeo para nivel de aceite  |    |
|   |   |    |
|  | <b>04</b> Zylinder<br>Cylinder<br>Cylindre<br>Cilindro  | 48 |
|   |   |    |
|  | <b>05</b> Kurbelwelle<br>Crankshaft<br>Vilebrequin<br>Cigüeñal  | 49 |
|   | <b>05</b> Keilriemenscheibe<br>V-belt pulley<br>Poulie de courroie trapézoïdale<br>Polea acanalada  | 50 |



Baugruppen - Verzeichnis  
 Index of Construction Groups  
 Index des Groupes de Construction  
 Indice de los Grupos de Construcción

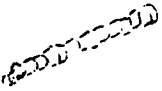



| Baugruppe: Constr. Group: Groupe/Grupo Constr.:                                     |  | S./P. |
|---|--|-------|
|    | <b>05</b> Schwingungsdämpfer<br>Vibration damper<br>Amortisseur de vibrations<br>Amortiguador de vibraciones                       |       |
|   | <b>05</b> Schwungrad<br>Flywheel<br>Volant<br>Volante  | 51    |
|   | <b>05</b> Zahnkranz<br>Ring gear<br>Couronne dentée<br>Corona dentada  |       |
|   |  |       |
|    | <b>06</b> Pleuelstange<br>Connecting rod<br>Bielle<br>Biela  | 52    |
|  | <b>07</b> Kolben<br>Piston<br>Piston<br>Embolo   | 53    |
|  | <b>08</b> Zylinderkopf<br>Cylinder head<br>Culasse<br>Culata   | 54    |
|   | <b>08</b> Zylinderkopfhaube<br>Rocker chamber cover<br>Culasse<br>Caperuza de culata   | 57    |
|   |  |       |
|  | <b>10</b> Nockenwelle<br>Camshaft<br>Arbre à cames<br>Árbol de levas   | 58    |
|   | <b>10</b> Nockenwellen Abtrieb<br>Camshaft drive<br>Prise de mouvement sur arbre à cames<br>Entrega de fuerza en el árbol de levas |       |
|   |  |       |
|  | <b>11</b> Steuerungsteile<br>Timing gears<br>Organes de distribution<br>Partes de distribución                                     | 59    |
|  | <b>14</b> Schmierölpumpe<br>Lube oil pump<br>Pompe d'huile de graissage<br>Bomba de aceite lubricante                              | 60    |

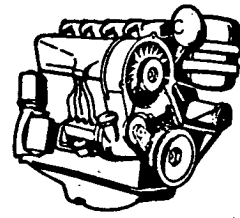

Baugruppen - Verzeichnis  
 Index of Construction Groups  
 Index des Groupes de Construction  
 Indice de los Grupos de Construcción





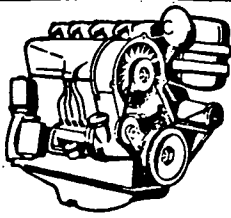

| Baugruppe: Constr. Group: Groupe/Grupo Constr.:  |  | S./P.  |
|--|--|--|
|   | <b>14</b> Absaugpumpe<br>Drain pump<br>Pompe de renvoi<br>Bomba recuperac  |  |
|   | <b>15</b> Schmierölfilter<br>Lube oil filter<br>Filtre à huile-moteur<br>Filtro de aceite lubricante   | 61   |
|  | <b>15</b> Nebenstromfeinfilter<br>By-pass microfilter<br>Filtre fin en dérivation<br>Microfiltro en corriente secundaria                                 |  |
|  | <b>15</b> Filterpatrone<br>Filter cartridge<br>Cartouche de filtre<br>Cartucho de filtro   |  |
|  | <b>15</b> Spaltfilteranbau<br>Edge-type filter mounting<br>Pièces de fixation pour filtre à nettoyage mécanique<br>Sistema de montaje de filtro mecánico |  |
|  | <b>15</b> Flansch mit Befestigung<br>Flange with fastenings<br>Flasque et fixation<br>Brida con elementos de fijación                                    |  |
|  | <b>15</b> Ventil<br>Valve<br>Vanne<br>Válvula  |  |
|  | <b>15</b> Schmierölkühler<br>Lube oil cooler<br>Radiateur d'huile de graissage<br>Refrigerador de aceite lubricante                                      |  |
|  | <b>15</b> Wandlerölkühler<br>Torque converter oil cooler<br>Refroidisseur d'huile de convertisseur<br>Refrigerador de aceite de convertidor              |  |
|  | <b>15</b> Hohlschraube<br>Banjo bolt<br>Vis banjo<br>Tornillo racor  |  |
|  |   | <b>16</b> Öldruckrohr<br>Oil delivery pipe<br>Tube de refoulement d'huile<br>Tubo de presión de aceite |
| <b>16</b> Schmierölanaugleitung<br>Lube oil suction pipe<br>Tuyau d'aspiration d'huile<br>Tubería de aspiración de aceite lubricante |  | 63   |
| <b>16</b> Schmierölleitung<br>Lube oil pipe<br>Conduite d'huile de graissage<br>Tubería de aceite lubricante                         |  |  |



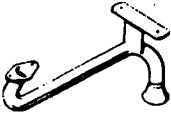

Baugruppen - Verzeichnis  
Index of Construction Groups  
Index des Groupes de Construction  
Indice de los Grupos de Construcción



| Baugruppe: Constr. Group: Groupe/Grupo Constr.:                                     |   | S./P. |
|---|---|-------|
|    | <b>16</b> Kurzschlußleitung<br>By-pass line<br>Conduite de by-pass<br>Tubería by-pass   | 64    |
|   |   |       |
|    | <b>17</b> Einspritzpumpe<br>Injection pump<br>Pompe d'injection<br>Bomba de inyección   | 65    |
|   | <b>17</b> Verteilereinspritzpumpe<br>Distributor injection pump<br>Pompe distributrice d'injection<br>Bomba de inyección, de pistón de distribución |       |
|   | <b>17</b> Überströmventil<br>Overflow valve<br>Valve de décharge<br>Válvula de rebosamiento   | 66    |
|   | <b>17</b> Drehzahlverstellung<br>Speed control<br>Changement de vitesse<br>Graduación de revoluciones   |       |
|   | <b>17</b> Rohrleitung<br>Piping<br>Tuyauteries<br>Tuberías  |       |
|  | <b>18</b> Spritzversteller<br>Advance / retard unit<br>Avance automatique<br>Graduador de avance de inyección                                       |       |
|   | <b>18</b> Einspritzpumpenantrieb<br>Injection pump drive<br>Entrainement de pompe d'injection<br>Accionamiento para bomba de inyección              | 67    |
|  | <b>19</b> Einspritzventil<br>Injector<br>Injecteur<br>Inyector  | 68    |
|   |   |       |
|  | <b>20</b> Kraftstofffilter<br>Fuel filter<br>Filtre nourrice<br>Filtro de combustible   | 69    |
|   | <b>20</b> Konsole mit Befestigung<br>Bracket with fastenings<br>Console avec fixation<br>Consola con elementos de fijación                          |       |



Baugruppen - Verzeichnis  
 Index of Construction Groups  
 Index des Groupes de Construction  
 Indice de los Grupos de Construcción

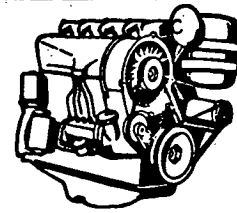

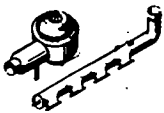

| Baugruppe: Constr. Group: Groupe/Grupo Constr.:                                     |   | S./P. |
|---|---|-------|
|    | <b>21</b> Einspritzleitungen<br>Injection pipes<br>Tuyauteries de injection<br>Tuberías de inyección  | 70    |
|   | <b>21</b> Überströmventil<br>Overflow valve<br>Valve de décharge<br>Válvula de rebosamiento   |       |
|   | <b>21</b> Kraftstoffleitungen<br>Fuel pipes<br>Tuyauteries à combustible<br>Tuberías de combustible   | 71    |
|   | <b>21</b> Kraftstoffleitungen<br>Fuel pipes<br>Tuyauteries à combustible<br>Tuberías de combustible   |       |
|   | <b>21</b> Überströmleitung<br>Overflow pipe<br>Conduit de décharge<br>Tubería de rebosamiento   | 72    |
|   | <b>21</b> Leckölleitungen<br>Leak oil pipes<br>Tuyauteries des fuites<br>Tuberías de combustible sobrante   | 73    |
|   | <b>21</b> Kraftstoffbehälter mit Befestigung<br>Fuel tank with fastenings<br>Réservoir à gas-oil avec attaches<br>Tanque de combustible con elementos de fijación                 |       |
|   | <b>21</b> Tragschiene mit Befestigung<br>Carrier rail with fastenings<br>Barrette-support avec fixation<br>Carril de soporte con elementos de fijación                            |       |
|  | <b>22</b> Luftansaugrohr<br>Air intake manifold<br>Tuyau d'admission d'air<br>Tubo de aspiración de aire  | 74    |
|   | <b>22</b> Anschlußkrümmer<br>Connecting elbow<br>Coude raccord<br>Codo de empalme   |       |
|   | <b>22</b> Ölbadluftfilter<br>Oil bath air cleaner<br>Épurateur d'air à bain d'huile<br>Filtro de aire en baño de aceite   |       |
|   | <b>22</b> Ölbadluftfilterbefestigung<br>Oil-bath air cleaner fixation<br>Fixation d'épurateur d'air à bain d'huile<br>Elementos de fijación para filtro de aire en baño de aceite |       |

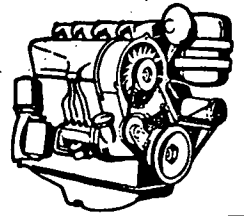

Baugruppen - Verzeichnis  
 Index of Construction Groups  
 Index des Groupes de Construction  
 Índice de los Grupos de Construcción

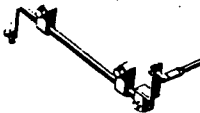

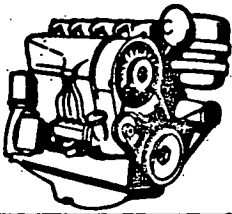

| Baugruppe: Constr. Group; Groupe/Grupo Constr.:                                     |   | S./P. |
|---|---|-------|
|    | <b>26</b> Elektrische Leitungen<br>Wiring<br>Câbles<br>Cables   |       |
|   | <b>26</b> Glühanlage<br>Heater plug installation<br>Equipement de préchauffage<br>Sistema de incandescencia                               |       |
|   | <b>26</b> Verbindungsschiene<br>Interplug connector<br>Barrette de connexion<br>Carril de ligación  |       |
|   | <b>26</b> Glühstiftkerze<br>Pin-type glow plug<br>Bougie à crayon<br>Bujia de espiga de incandescencia                                    |       |
|   |   |       |
|  | <b>29</b> Drehzahl-Feineinstellung<br>Vernier speed control<br>Réglage précis de la vitesse<br>Sistema de micrograduación de revoluciones |       |
|  | <b>33</b> Luftpresse<br>Air compressor<br>Compresseur d'air<br>Compresor de aire  |       |
|   | <b>33</b> Antriebsteile<br>Driving parts<br>Pièces d'entraînement<br>Piezas de accionamiento  |       |
|   | <b>33</b> Verschlusssteile<br>Locking parts<br>Pièces de fermeture<br>Partes de cierre  | 75    |
|   | <b>33</b> Saugleitung<br>Suction pipe<br>Conduite d'aspiration<br>Tubería de aspiración   |       |
|   | <b>33</b> Naßluftfilter<br>Wet air cleaner<br>Filtre d'air humecté d'huile<br>Filtro de aire tipo húmedo                                  |       |
|   | <b>33</b> Druckregler<br>Pressure regulator<br>Régulateur de pression<br>Regulador de presión   |       |
|   | <b>33</b> Keilriemenscheibe<br>V-belt pulley<br>Poulie de courroie trapézoïdale<br>Polea acanalada  |       |



Baugruppen - Verzeichnis  
 Index of Construction Groups  
 Index des Groupes de Construction  
 Indice de los Grupos de Construcción

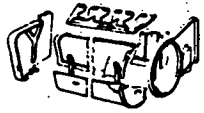

| Baugruppe: Constr. Group: Groupe/Grupo Constr.:                                     |   | S./P. |
|---|---|-------|
|    | <b>33</b> Druckölleitung<br>Pressure oil pipe<br>Conduite d'huile sous pression<br>Tuberna de aceite a presión  |       |
|   | <b>33</b> Anbauteile für Luftpresse<br>Mounting parts for air compressor<br>Pièces de fixation de compresseur d'air<br>Partes de montaje para compresor de aire |       |
|   |   |       |
|    | <b>35</b> Armaturenkasten<br>Instrument panel<br>Tableau de bord<br>Caja de instrumentos  |       |
|   | <b>35</b> Konsole<br>Bracket<br>Console<br>Consola  |       |
|   |   |       |
|  | <b>39</b> Kühlgebläse<br>Cooling air blower<br>Turbine de refroidissement<br>Ventilador de refrigeración  | 76    |
|   | <b>39</b> Keilriemen<br>V-belt<br>Courroie trapézoïdale<br>Correa trapezoidal   |       |
|  | <b>40</b> Luftführungsleiste<br>Baffle mounting plate<br>Plinthe de hotte de guidage d'air<br>Listón guía de aire   | 77    |
|   | <b>40</b> Luftführungshaube<br>Air cowling<br>Manche d'air<br>Manga guía de aire  |       |
|   | <b>40</b> Verschlussblech<br>Closing sheet<br>Tôle d'obturation<br>Chapa de cierre  |       |
|   | <b>40</b> Standblech (hinten)<br>Stay plate, rear<br>Tôle verticale (AR)<br>Chapa vertical (atrás)  | 78    |
|   | <b>40</b> Luftführungsunterteil<br>Air cowling base<br>Partie inférieur hotte guidage d'air<br>Parte inferior de guía de aire                                   | 79    |



Baugruppen - Verzeichnis  
 Index of Construction Groups  
 Index des Groupes de Construction  
 Indice de los Grupos de Construcción

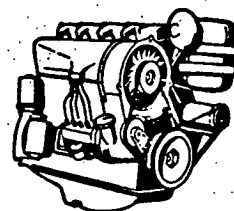

| Baugruppe: Constr. Group: Groupe/Grupo Constr.: |  | S./P.  |
|---|--|--|
|   | <b>40</b> Luftführungs-Oberteil<br>Air guide upper part<br>Part sup cart vent<br>Parte sup. guia de adre   | 80   |
|   | <b>40</b> Luftführungsblech<br>Air guide plate<br>Tôle défectrice d'air<br>Chapa guia de aire  |  |
|   | <b>40</b> Abluftkasten<br>Air discharge frame<br>Hotte de départ d'air vicié<br>Caja de evacuación de aire   |  |
|   | <b>40</b> Seitendeckel<br>Side cover<br>Couvercle latéral<br>Tapa lateral  |  |
|   | <b>40</b> Verschlussdeckel<br>Cover<br>Couvercle<br>Tapa   |  |
|   | <b>40</b> Abschirmblech<br>Air shield<br>Tôle défectrice<br>Chapa deflectora   | 81   |
|   | <b>40</b> Standblech (vorne)<br>Stay plate, front<br>Tôle verticale (AV)<br>Chapa vertical (delante)   | 82   |
|   | <b>40</b> Heizkasten<br>Heater box<br>Boite de chauffage<br>Caja de calefacción  |  |
|   | <b>40</b> Luftzuführungsring<br>Air guide ring<br>Bague d'arrivée d'air<br>Aro de entrada de aire  |  |
|   | <b>40</b> Abdichtbürste<br>Sealing brush<br>Brosse de collerette<br>Cepillo de hermetización   |  |
|   | <b>40</b> Kühlluftführung für Generator<br>Cooling air duct for generator<br>Gaine d'air de refroidissement pour l'alternateur<br>Conducción de aire para generatriz |  |
|   | <b>40</b> Abluftteile<br>Exhaust-air cowling parts<br>Tôlerie de sortie d'air<br>Partes para sistema de desviación de aire   |  |
|   |  | <b>41</b> Auspuffsammelrohr<br>Exh. manifold<br>Collecteur d'échappement<br>Colector de escape |

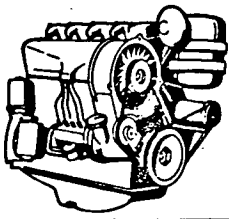

Baugruppen - Verzeichnis  
 Index of Construction Groups  
 Index des Groupes de Construction  
 Índice de los Grupos de Construcción



Baugruppe: Constr. Group: Groupe/Grupo Constr.:



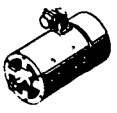

S./P.

|   |           |   |    |
|---|-----------|---|----|
|    | <b>41</b> | Auspuffsammelrohr<br>Exh. manifold<br>Collecteur d'échappement<br>Colector de escape                                | 84 |
|   | <b>41</b> | Auspuffsammeldämpfer<br>Exh. silencing manifold<br>Collecteur silencieux d'échappement<br>Silenciador de escape     |    |
|   | <b>41</b> | Gegenflansch<br>Counterflange<br>Contre-bride<br>Contrabrida  |    |
|   | <b>41</b> | Befestigungsteile<br>Fastening parts<br>Pièces de fixation<br>Partes de fijación                                    |    |
|   | <b>41</b> | Auspuffrohrverbindung<br>Exhaust manifold connection<br>Raccord de tuyau d'échappement<br>Unión para tubo de escape |    |
|   | <b>41</b> | Reduzierstück<br>Reducer<br>Pièce de réduction<br>Reductor  |    |
|   |           |   |    |
|  | <b>44</b> | Lichtmaschine<br>Dynamo<br>Dynamo<br>Generatriz   | 85 |
|   | <b>44</b> | Antriebssteile<br>Driving parts<br>Pièces d'entraînement<br>Piezas de accionamiento                                 | 86 |
|   | <b>44</b> | Befestigungsteile<br>Fastening parts<br>Pièces de fixation<br>Partes de fijación                                    | 87 |
|   | <b>44</b> | Keilriemenscheibe<br>V-belt pulley<br>Poulie de courroie trapézoïdale<br>Polea acanalada                            |    |
|   | <b>44</b> | Keilriemen<br>V-belt<br>Courroie trapézoïdale<br>Correa trapezoidal   | 88 |
|   | <b>44</b> | Abschirmblech<br>Air shield<br>Tôle déflectrice<br>Chapa deflector  | 89 |
|   | <b>44</b> | Reglerschalter<br>Regulator cutout<br>Disjoncteur-régulateur<br>Disyuntor   | 90 |
|   |           |   |    |

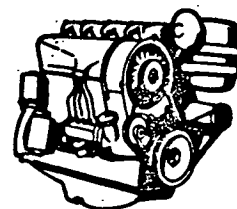

Baugruppen - Verzeichnis  
 Index of Construction Groups  
 Index des Groupes de Construction  
 Indice de los Grupos de Construcción





| Baugruppe: Constr. Group: Groupe/Grupo Constr.:  |  | S./P. |
|--|--|-------|
| <br><br> | <b>44</b> Steckverbindung<br>Plug & socket connection<br>Prise et fiche<br>Unión de enchufe                                      |       |
|  | <b>44</b> Elektr. Anlasser<br>Electr. starter motor<br>Démarreur électr.<br>Arrancador eléctrico                                 | 91    |
|  | <b>44</b> Schutzkappe<br>Protective cape<br>Chapeau de protection<br>Sombrero de protección                                      |       |
|  |  |       |
|   | <b>46</b> Motoraufhängung<br>Engine suspension<br>Suspension du moteur<br>Suspensión del motor                                   |       |
|  |  |       |
|   | <b>48</b> Elektrische Leitungen<br>Wiring<br>Câbles<br>Cables  |       |
|  | <b>48</b> Öl druckschalter<br>Oil press. switch<br>Commutateur à pression d'huile<br>Conmutador para presión de aceite           | 92    |
|  | <b>48</b> Öl druckgeber<br>Oil pressure switch<br>Mano-contact d'huile<br>Transmisor de presión de aceite                        |       |
|  | <b>48</b> Elektrisches Grundzubehör<br>Basic electr. accessories<br>Accessoires électr. de base<br>Accesorios eléctricos básicos |       |
|  | <b>48</b> Glühlampen<br>Bulbs<br>Lampes à incandescence<br>Bombillas   |       |
|  | <b>48</b> Anschlußstelle<br>Connecting parts<br>Pièces d'adaptation<br>Piezas de conexión  |       |
|  | <b>48</b> Anzeigeleuchte<br>Pilot lamp<br>Lampe-témoin<br>Lámpara indicadora   |       |
|  | <b>48</b> Batterie-Umschalter<br>Battery changeover switch<br>Commutateur de batterie<br>Conmutador de batería                   |       |
|  |  |       |



Baugruppen - Verzeichnis  
Index of Construction Groups  
Index des Groupes de Construction  
Indice de los Grupos de Construcción



Fahrzeug und Getriebegruppen / Vehicle and Transmission Assemblies  
Ensembles Tracteur - Transmissions / Grupos: Vehiculo - Transmission

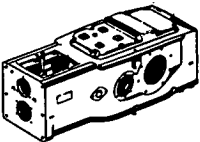
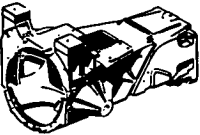
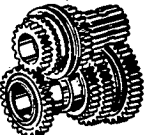

| Baugruppe/Constr. Group/Groupe/Grupo Constr.  |  | S./P.       |
|---|--|-------------|
|    | <b>02</b> KUPPLUNG<br>CLUTCH<br>EMBAYAGE<br>EMBRAGUE   | 93-<br>96   |
|    | <b>03</b> KUPPLUNGSBETÄTIGUNG<br>CLUTCH CONTROL ASSEMBLY<br>ACTIONNEMENT D EMBRAYAGE<br>ACCIONAMIENTO DEL EMBRAGUE | 97-<br>101  |
|   |  |             |
|   |  |             |
|   |  |             |
|   |  |             |
|  | <b>08</b> GETRIEBEGEHÄUSE<br>TRANSMISSION CASE<br>CARTER DE TRANSMISSION<br>CAJA DEL TREN DE ENGRANAJES            | 102-<br>104 |
|  | <b>09</b> KUPPLUNGSGEHÄUSE<br>CLUTCH HOUSING<br>CLOCHE D EMBRAYAGE<br>CAJA DEL AMBRAGUE                            | 105         |
|   |  |             |
|  | <b>11</b> WECHSELGETRIEBE<br>CHANGE-SPEED GEARBOX<br>BOITE DE VITESSES<br>CAMBIO DE MARCHAS                        | 106-<br>114 |



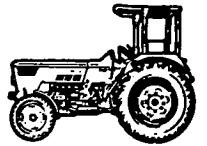

Baugruppen - Verzeichnis  
 Index of Construction Groups  
 Index des Groupes de Construction  
 Indice de los Grupos de Construcción

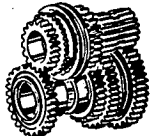
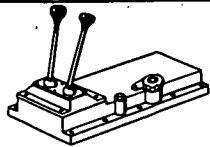

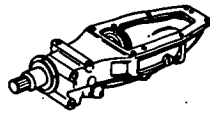
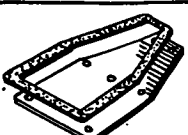



| Baugruppe/Constr. Group/Groupe/Grupo Constr.  |  | S./P.       |
|---|--|-------------|
|    | <b>11</b><br>KRIECHGANG<br>CREEP GEAR<br>RAPPORT ULTRA-LENT<br>GRUPO DEMARCHAS ULTRALENTAS   |             |
|    | <b>12</b><br>SCHALTUNG ZUM WECHSELGETRIEBE<br>GEAR-SHIFT ASSEMBLY<br>ORGANES D ACTIONNEMENT DE LA BOITE DE VITESSES<br>MANDO PARA CAJA DE VELOCIDADES  | 115-<br>123 |
|   | SCHALTUNG ZUM WECHSELGETRIEBE BEI KRIECHGANG<br>GEARSHIFT ASSEMBLY FOR TRACTOR WITH CREEP GEAR<br>COMMANDE DE BOITE DE VITESSES AVEC RAPPORT ULTRA-LENT<br>MANDO PARA CAMBIO, EXISTIENDO GRUPO MARCHAS ULTRALENTAS |             |
|   | GETR.-SCHALTUNG MIT ANLASS-SPERRE<br>GEARSHIFT ASSEMBLY WITH START INTERLOCK<br>ORGANES D ACTIONNEMENT AVEC SECURITE DE DEMARR.<br>MANDO TRANSMISION C. BLOQUEO CONTRA ARRANQUE                                    |             |
|  | <b>14</b><br>ZAPFWELLENSCHALTUNG<br>PTO CONTROL ASSEMBLY<br>COMMANDE DU MECANISME MENANT P.D.F.<br>MANDO PARA ARBOL TOMA FUERZA  | 124-<br>125 |
|   | VERSCHLUSSDECKEL - (ZAPFW.-SCHALTUNG)<br>CLOSING COVER - (PTO CONTROL ASSEMBLY)<br>COUVERCLE DE FERM - (COMM.D. PRISE D. FORCE)<br>CIERRE DE TAPA - (MANDO PARA ARBOL TOMA DE FUERZA)                              |             |
|  | <b>16</b><br>VERSCHLUSSDECKEL - (VORGELEGE BREMSE )<br>CLOSING COVER - (LAYSHAFT BRAKE)<br>COUVERCLE DE FERM - (FREIN SUR LA TRANSMISSION)<br>CIERRE DE TAPA - (FRENO ACTUANDO SOBRE LA TRANSMISION)               |             |
|  | <b>17</b><br>MÄHBALKENANTRIEB<br>MOVER DRIVE<br>MECANISME D. COMM. BARRE D. COUPE)<br>ACCIONAMIENTO D. SEGADORA)   | 126-<br>127 |
|   | VERSCHLUSSDECKEL - (MÄHBALKENANTRIEB)<br>CLOSING COVER - (MOVER DRIVE)<br>COUVERCLE DE FERM - (MECANISME D.COMM.BARRE D. COUPE)<br>CIERRE DE TAPA - (ACCIONAMIENTO D. SEGADORA)                                    |             |
|  | <b>18</b><br>SCHALTUNG FÜR MÄHBALKENANTRIEB<br>MOVER DRIVE CONTROL ASSEMBLY<br>COMMANDE BARRE DE COUPE<br>CONNEXION PARA ACCIONAMIENTO DE SEGADORA   |             |

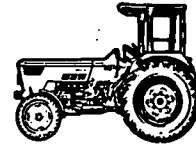

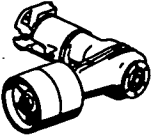
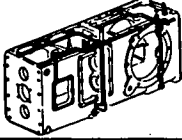
Baugruppen - Verzeichnis  
 Index of Construction Groups  
 Index des Groupes de Construction  
 Indice de los Grupos de Construccion

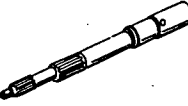
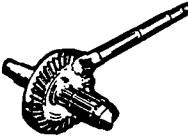

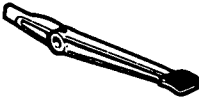
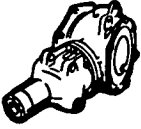
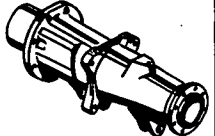



| Ba ugruppe/Constr. Group/Groupe/Grupo Constr.                                       |  | S./P.       |
|---|--|-------------|
|    | <b>19</b><br>RIEMENSCHIBENANTRIEB<br>BELT PULLEY DRIVE<br>MECANISME ENTRAINEMENT POULIE DE BATTAGE<br>ACCIONAMIENTO DE POLEA               | 128-<br>131 |
|    | <b>20</b><br>ÖLLEITUNGEN IM GETRIEBE<br>OIL PIPING IN TRANSMISSION<br>CONDUITES D HUILE DANS BOITE<br>TUBERIAS DE ACEITE EN LA TRANSMISION |             |
|    | <b>21</b><br>GELENKWELLE<br>JOINT SHAFT<br>ARBRE A CARDANS<br>ARBOL CARDAN   | 132         |
|    | <b>22</b><br>ANTRIEBSWELLE<br>DRIVE SHAFT<br>ARBRES D ENTRAINEMENT<br>EJES DE ACCIONAMIENTO  | 133         |
|   | <b>23</b><br>KEGELTRIEB<br>BEVEL DRIVE<br>COUPLE CONIQUE<br>GRUPO CONICO   | 134-<br>135 |
|  | <b>24</b><br>AUSGLEICHGETRIEBE<br>DIFFERENTIAL UNIT<br>DIFFERENTIEL<br>DIFERENCIAL   | 136         |
|  | <b>25</b><br>AUSGLEICHGETRIEBESPERRE<br>DIFFERENTIAL LOCK<br>BLOCAGE DU DIFFERENTIEL<br>BLOQUEO DEL DIFERENCIAL                            | 137         |
|   | VERSCHLUSSTEILE (HINTERACHSE)<br>BLANKING PARTS FOR REAR AXLE<br>OBTURATIONS (PONT ARRIERE)<br>PIEZAS DE CIERRE (EJE TRASERO)              |             |
|  | <b>26</b><br>VORDERRADANTRIEB<br>FRONT WHEEL DRIVE<br>COMMANDE DES ROUES AV<br>PROPULSION DELANTERA  | 138-<br>143 |
|   | ANLAUFKUPPLUNG<br>SLIP CLUTCH FOR FRONT WHEEL DRIVE<br>LIMITEUR DE COUPLE<br>ACOPLAMIENTO DE RESBALAMIENTO                                 |             |
|   | SCHALTUNG FÜR VORDERRADANTRIEB<br>FRONT WHEEL DRIVE CONTROL ASSEMBLY<br>COMMANDE DU PONT-MOTEUR AV<br>CONEXION PARA TRACCION DELANTERA     |             |
|  | <b>27</b><br>HINTERACHSE<br>STANDARD REAR AXLE<br>TRAIN AR<br>PUENTE TRASERO   | 144-<br>149 |

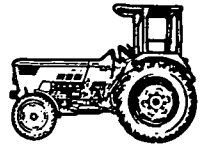

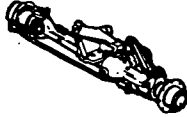
Baugruppen - Verzeichnis  
 Index of Construction Groups  
 Index des Groupes de Construction  
 Indice de los Grupos de Construcción

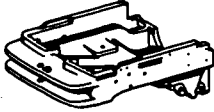



| Baugruppe/Constr. Group/Groupe/Grupo Constr.  |  | S./P.       |
|---|--|-------------|
|    | <b>28</b><br>ANGETRIEBENE VORDERACHSE<br>DRIVEN FRONT AXLE<br>ESSIEU AV MOTEUR<br>EJE DELANTERO CON ACCIONAMIENTO  | 150-<br>154 |
|    | <b>29</b><br>FESTSTELLBREMSE<br>PARKING BRAKE<br>FREIN DE STATIONNEMENT<br>FRENO DE ESTACIONAMIENTO  | 155-<br>156 |
|   | FESTSTELLBETÄTIGUNG<br>CONTROL ASSEMBLY FOR PARKING BRAKE<br>MECANISME D ACTIONNEMENT DU FREIN DE STATIONNEMENT<br>ACCIONAMIENTO PARA FRENO DE ESTACIONAMIENTO |             |
|    | <b>30</b><br>HINTERRADBREMSE<br>REAR WHEEL BRAKE<br>FREIN ARRIERE<br>FRENO DE RUEDAS TRASERAS  | 157-<br>165 |
|   | HINTERRAD-BREMSBETÄTIGUNG<br>REAR WHEEL BRAKE CONTROL ASSEMBLY<br>ACTIONNEMENT DU FREIN - ARRIERE<br>ACCIONAMIENTO DE FRENO DE RUEDAS TRASERAS                 |             |
|   | FESTSTELLBREMSE<br>PARKING BRAKE<br>FREIN DE STATIONNEMENT<br>FRENO DE ESTACIONAMIENTO   |             |
|   | BETR. - UND FESTSTELLBREMSE<br>OPERATING AND PARKING BRAKE<br>FREIN MECANIQUE ET D'IMMOBILISATION<br>FRENO DE RODADURA Y DE ESTACIONAMIENTO                    |             |
|  | <b>32</b><br>VORDERACHSLAGERBOCK<br>FRONT AXLE BRACKET<br>BERCEAU DE L ESSIEU AV<br>CABALLETE DE SOPORTE DEL EJE DELANTERO                                     | 166-<br>168 |
|   | RANGIERKUPPLUNG<br>FRONT TOWING CLEVIS<br>ACCOUPLEMENT DE MANOEUVRE<br>ACOUPLE PARA MANIOBRAS  |             |
|  | <b>33</b><br>VORDERACHSE<br>FRONT AXLE<br>ESSIEU AV<br>EJE DELANTERO   | 169-<br>176 |

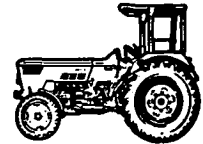

Baugruppen - Verzeichnis  
Index of Construction Groups  
Index des Groupes de Construction  
Indice de los Grupos de Construcción

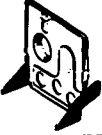
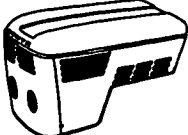
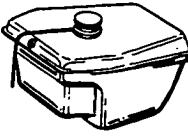

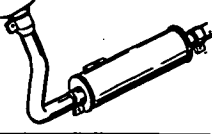



| Baugruppe/Constr. Group/Groupe/Grupo Constr.  |  | S./P.       |
|---|--|-------------|
|    | <b>37</b><br>LENKUNG<br>STEERING-SYSTEM<br>DIRECTION<br>DIRECCION  | 177-<br>187 |
|    | <b>38</b><br>TRENNWAND<br>BULKHEAD<br>CLOISON DE SEPARATION<br>TABIQUE DE SEPARACION   | 188-<br>189 |
|   |  |             |
|   |  |             |
|   | <b>41</b><br>MOTORHAUBE<br>ENGINE HOOD<br>CAPOT MOTEUR<br>CAPOT DE MOTOR   | 190-<br>193 |
|  | <b>42</b><br>KRAFTSTOFFBEHÄLTER<br>FUEL TANK<br>RESERVOIR A COMBUSTIBLE<br>TANQUE DE COMBUSTIBLE   | 194-<br>196 |
|   | KRAFTSTOFF-FILTER<br>FUEL FILTER<br>FILTRE A COMBUSTIBLE<br>FILTRO DE COMBUSTIBLE  |             |
|   | SCHLAUCHLEITUNG - ZUSATZKRAFTSTOFFBEHÄLTER (CAN.)<br>HOSE PIPE-FUEL TANK/ SECOND<br>FLEXIBLE-RESERVOIR A GAS-OIL/Z<br>MANGUERA TANQUE DE COMBUSTIBLE/Z |             |
|  | <b>43</b><br>LUFTFILTER<br>AIR CLEANER<br>EPURATEUR D AIR<br>FILTRO DE AIRE  | 197-<br>203 |
|   | UNTERDRUCKANZEIGE - ELEKTRISCH<br>CONTAMINATION INDICATOR - EL.<br>INDICATEUR DE DEPRESSION - EL.<br>INDICATOR DE DEPRESSION - EL.                     |             |
|  | <b>44</b><br>AUSPUFFANLAGE<br>EXHAUST SILENCER AND PIPING<br>ECHAPPEMENT<br>SISTEMA DE ESCAPE  | 204-<br>206 |
|   |  |             |

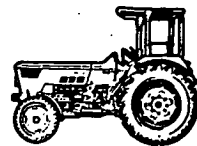

Baugruppen - Verzeichnis  
 Index of Construction Groups  
 Index des Groupes de Construction  
 Indice de los Grupos de Construcción

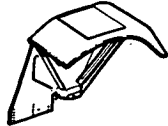
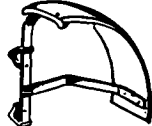





| Baugruppe/Constr. Group/Groupe/Grupo Constr.  |  | S./P.       |
|---|--|-------------|
|    | <b>46</b><br>DREHZAHLVERSTELLUNG<br>SPEED CONTROL DEVICE<br>SYSTEME D ACCELERATION<br>SISTEMA DE ACELERACION                         | 207-<br>209 |
|    | <b>47</b><br>ABSTELLVORRICHTUNG<br>SHUT-DOWN DEVICE<br>DISPOSITIF D ARRET<br>DISPOSITIVO DE PARADA                                   | 210         |
|    | <b>49</b><br>ELEKTRISCHE AUSRÜSTUNG<br>ELECTRICAL EQUIPMENT<br>EQUIPEMENT ELECTRIQUE<br>EQUIPO ELECTRICO                             | 211-<br>229 |
|   | SCHEIBENWASCHANLAGE<br>WINDSC.-WASHER<br>LAVE-GLACE<br>EQU. LAVA PARA BRISAS   |             |
|  | <b>51</b><br>HINTERE KOTFLÜGEL<br>REAR MUDGUARDS, STANDARD<br>GARDE-BOUE AR<br>GUARDABARROS TRASEROS                                 | 230-<br>234 |
|   | HINTERE VERKLEIDUNG<br>REAR PANELLING<br>HABILLAGE AR<br>REVESTIMIENTO POSTERIOR   |             |
|   | BODENBELAG B. FAHRERKABINE<br>FLOOR LINING-DRIVER S CAB.<br>GARNITRE DE PLANCH - CABINE DE CONDUCT<br>REV. DEL PISO-CAB. D/CONDUCTOR |             |
|  | <b>52</b><br>KOTFLÜGEL VORN<br>FRONT MUDGUARDS, STANDARD<br>AILES AV<br>GUARDABARROS DELANTEROS                                      | 235-<br>237 |
|  | <b>54</b><br>FAHRERSITZ<br>DRIVER S SEAT<br>SIEGE DU CONDUCTEUR<br>ASIENTO DEL CONDUCTOR   | 238-<br>246 |

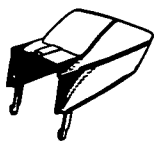

Baugruppen - Verzeichnis  
 Index of Construction Groups  
 Index des Groupes de Construction  
 Indice de los Grupos de Construcción



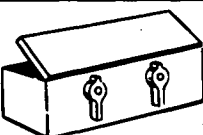
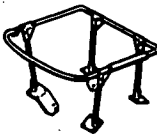
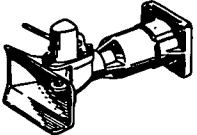
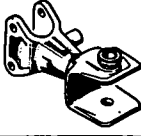



| Baugruppe/Constr. Group/Groupe/Grupo Constr.  |  | S./P.       |
|---|--|-------------|
|    | <b>55</b> VERKLEIDUNGSKASTEN<br>TANK PANNELLING<br>HABILLAGE<br>CAJA DE REVESTIMIENTO  | 247         |
|    | <b>56</b> TRAKTORMETER<br>TRACTORMETER<br>TRACTORMETRE<br>TRACTOMETRO  | 248         |
|    | <b>57</b> VERSCHLUSS-STOPFEN<br>SCREW PLUG<br>BOUCHON D OBTURATION<br>TAPON ROSCADO  | 249         |
|    | <b>58</b> SCHEIBENRÄDER VORN<br>DISC WHEELS, FRONT<br>ROUES A VOILE PLEIN AV<br>RUEDAS DE PLATO DELANTERAS                           | 250         |
|   | <b>59</b> SCHEIBENRÄDER HINTEN<br>REAR DISC WHEELS<br>RUES A VOILE PLEIN<br>RUEDAS DE PLATO, ATRAS                                   | 251-<br>252 |
|   | VERSTELLRÄDER<br>BOWL WHEELS, ADJUSTABLE-GAUGE<br>ROUES A GRADINS<br>RUEDAS DE MODIFICACION DE ANCHO DE RODADA                       |             |
|  | <b>60</b> WERKZEUGKASTEN<br>TOOLBOX<br>COFFRET A OUTILS<br>CAJA DE HERRAMIENTAS  | 253         |
|  | <b>61</b> SCHUTZRAHMEN<br>SAFETY FRAME<br>CADRE DE PROTECTION<br>BASTIDOR SALVAVIDAS   | 254-<br>255 |
|  | <b>62</b> AUTOM. ANHÄNGERKUPPLUNG<br>AUTOMATIC TRAILER HITCH<br>ATTELAGE AUTOMATIQUE DE REMORQUE<br>ACOPLE AUTOMATICO PARA REMOLQUES | 256         |
|  | <b>63</b> ANHÄNGEKUPPLUNG<br>TRAILER HITCH, AUTOMATIC, RIGID<br>DISPOSITIF D ATTELAGE<br>ACOPLE PARA REMOLQUES                       | 257-<br>259 |
|   | SCHUTZSCHILD FÜR ZAPFWELLE<br>PTO MASTER SHIELD<br>DEFLECTEUR EMBOUT PRISE DE FORCE<br>PLACA PROTÉCTORA PARA ARBOL TOMA DE FUERZA    |             |
|   |  |             |

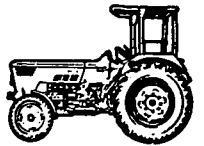

Baugruppen - Verzeichnis  
Index of Construction Groups  
Index des Groupes de Construction  
Indice de los Grupos de Construcción

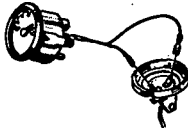

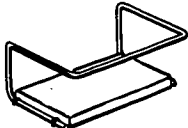

| Baugruppe/Constr. Group/Groupe/Grupo Constr.  |  | S./P.       |
|---|--|-------------|
|   |  |             |
|   |  |             |
|    | <b>67</b> RÜCKBLICKSPIEGEL<br>DRIVING MIRROR<br>RETROVISEUR<br>ESPEJO RETROVISOR.  | 260         |
|    | <b>68</b> RÜCKSTRAHLER<br>REAR REFLECTOR<br>CATADIOPTRE<br>REFLECTORES TRASEROS  | 261-<br>262 |
|   | <b>69</b> TANKINHALTSANZEIGE<br>FUEL GAUGE<br>JAUGE A COMBUSTIBLE<br>INDICACION PARA CONTENIDO DEL TANQUE  | 263         |
|  | <b>70</b> HALTER FÜR WARNDREIECK<br>RETAINER FOR WARNING TRIANGLE<br>SUPPORT POUR TRIANGLE DE PANNE<br>SOPORTE PARA TRIANGULO DE SITUACION DEL PELIGRO | 264         |
|  | <b>71</b> SCHILDER<br>MARKING PLATES<br>PLAQUES<br>ROTULOS   | 265-<br>268 |
|   |  |             |
|   |  |             |
|   |  |             |
|   |  |             |
|  | <b>76</b> BEIFAHRENSITZ<br>PASSENGER SEAT<br>SIEGE DE CONVOYEUR<br>ASIENTO PARA ACOMPAÑANTE  | 269         |

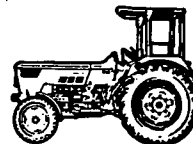

Baugruppen - Verzeichnis  
Index of Construction Groups  
Index des Groupes de Construction  
Indice de los Grupos de Construcción

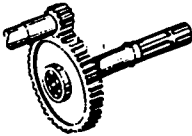

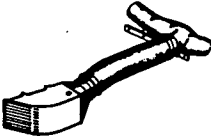
| Ba ugruppe/Constr. Group/Groupe/Grupo Constr.                                       |  | S./P.       |
|---|--|-------------|
|    | <b>77</b><br>ZAPFWELLE<br>STANDARD PTO SHAFT<br>PRISE DE FORCE<br>ARBOL TOMA DE FUERZA   | 270-<br>273 |
|   | VERSCHLUSSDECKEL - (ZAPFWELLE)<br>CLOSING COVER - (PTO SHAFT)<br>COUVERCLE DE FERM - (PRISE DE FORCE)<br>CIERRE DE TAPA - (ARBOL TOMA DE FUERZA) |             |
|   |  |             |
|   |  |             |
|   | <b>80</b><br>BREMSKLOTZ<br>WHEEL CHOCK<br>SABOT<br>ZAPATA DE FERNO   |             |
|   |  |             |
|   |  |             |
|   |  |             |
|   |  |             |
|  | <b>85</b><br>HEIZUNGSANLAGE<br>HEATING SYSTEM<br>CLIMATISATION<br>SISTEMA DE CALEFACCION   | 274         |
|   |  |             |
|   |  |             |





Baugruppen - Verzeichnis  
 Index of Construction Groups  
 Index des Groupes de Construction  
 Indice de los Grupos de Construcción

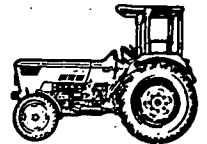

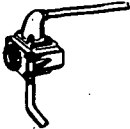
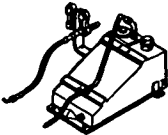
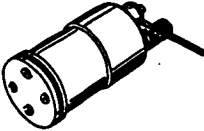
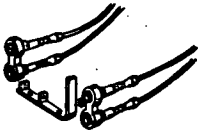

Anbaugruppen / Attachements  
 Equipments Portes / Grupos: Complementarios

| Baugruppe/Constr. Group/Groupe/Grupo Constr.  |   | S./P.       |
|---|---|-------------|
|    | <b>01</b><br>HYDR. PUMPE MIT LEITUNGEN<br>HYDRAULIC PUMP WITH PIPING<br>POMPE HYDRAULIQUE AVEC TUYAUTERIES<br>BOMBA HIDRAULICA CON TUBERIAS   | 275-<br>278 |
|   | ÖLBEHÄLTER FÜR HYDR. STAT. LENKUNG<br>OIL TANK FOR ALL-HYDRAULIC STEERING SYSTEM<br>RESERVOIR D HUILE POUR DIRECTION HYDRO-STATIQUE<br>TANQUE DE ACEITE PARA DIRECCION HIDROSTATICA |             |
|   |   |             |
|   |   |             |
|  | <b>04</b><br>REMOTE-CONTROL<br>INDEPENDENT REMOTE HYDRAULICS (TRACTOR W/O LIFT)<br>TELECOMMANDE HYDRAULIQUE<br>CONTROL REMOTO   | 279-<br>281 |
|   | GEHÄUSEDECKEL MIT FILTER<br>HOUSING COVER WITH CLEANER<br>COUVER DE CARTER AVEC FILTRE<br>TAPA DEL CARTER CON FILTRO  |             |
|   |   |             |
|  | <b>06</b><br>REGELSTEUERGERÄT<br>HYDRAULIC MAIN CONTROL UNIT<br>DISTRIBUTEUR PRINCIPAL<br>APARATO DE MANDO REGULADO   | 282-<br>285 |
|  | <b>07</b><br>REMOTE - ANSCHLÜSSE<br>AUXILIARY REMOTE HYDRAULICS (TRACTOR WITH LIFT)<br>RACCORDEMENTS DE TELECOMMANDE HYDRAULIQUE<br>EMPALMES PARA CONTROL REMOTO                    | 286-<br>288 |
|   | LECKÖLANSCHLÜSSE<br>LEAK-OFF CONNECTIONS<br>RACCORDS DE RECUPERATION DES EGOUTTURES<br>EMPALMES PARA COMBUSTIBLE SOBRANTE   |             |
|   | STEUERGERÄTE - WESTINGHOUSE<br>CONTROL UNITS, WESTINGHOUSE<br>DISTRIBUTEURS COMPLEMENTAIRES WESTINGHOUSE<br>APARATOS DE MANDO, TIPO WESTINGHOUSE                                    |             |

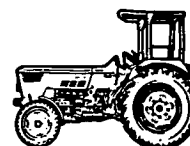

Baugruppen - Verzeichnis  
 Index of Construction Groups  
 Index des Groupes de Construction  
 Indice de los Grupos de Construcción

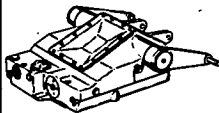

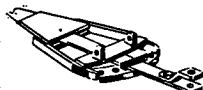
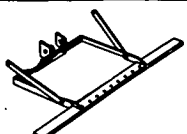

| Baugruppe/Constr. Group/Groupe/Grupo Constr.  |  | S./P.       |
|---|--|-------------|
|    | <b>08</b><br>KRAFTHEBER<br>HYDRAULIC LIFT<br>PIÈCES DÉTACHÉES DE RELEVAGE<br>PARTES INDIVIDUALES, ELEVADOR HIDRAULICO                                | 289-<br>302 |
|   | BETÄTIGUNG - KRAFTHEBER<br>CONTROL ASSEMBLY - HYDRAULIC LIFT<br>MECANISME DE COMMANDE - RELEVAGE HYDRAULIQUE<br>ACCIONAMIENTO DE ELEVADOR HIDRAULICO |             |
|   | ZUSATZ-ÖLBEHÄLTER<br>OIL TANK<br>CAISSON A FLUIDE HYDRAULIQUE<br>TANQUE DE ACEITE  |             |
|   |  |             |
|   |  |             |
|  | <b>11</b><br>DREIPUNKTKUPPLUNG<br>THREE-POINT LINKAGE<br>ATTELAGE FROIS POINTS<br>SISTEMA DE ACOPLAMIENTO EN 3 PUNTOS                                | 303-<br>312 |
|   |  |             |
|   |  |             |
|  | <b>14</b><br>ZUGPENDEL<br>DRAWBAR<br>BARRE OSCILLANTE<br>PENDULO DE TRACCION   | 313         |
|   | TRAGBÜGEL<br>BRACKET<br>SUPPORT<br>PUENTE DE SOPORTE   |             |
|  | <b>15</b><br>SCHIENE MIT PLATTFORM<br>TOOLBAR WITH PLATFORM<br>BARRE AGRICOLE AVEC PLATEFORME<br>BARRA DE ENGANCHE Y PLATAFORMA                      | 314         |
|   |  |             |

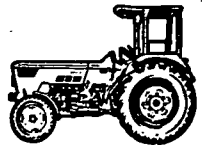

Baugruppen - Verzeichnis  
 Index of Construction Groups  
 Index des Groupes de Construction  
 Indice de los Grupos de Construcción

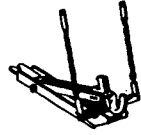
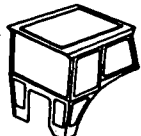
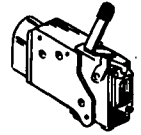
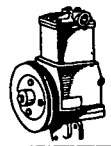
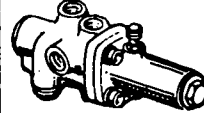
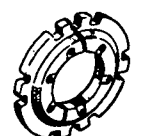

| Baugruppe/Constr. Group/Groupe/Grupo Constr.  |   | S./P.       |
|---|---|-------------|
|    | <b>17</b><br>DEUTZ-HITCH<br>DEUTZ-HITCH<br>PICK-HUP DEUTZ<br>ENGANCHE HIDRAULICO DEUTZ  | 315-<br>320 |
|    | <b>20</b><br>HUBKUPPLUNG<br>PICK-UP HITCH<br>PICK-UP D ATTELAGE<br>GANCHO DE ACOPLÉ, DE ELEVACION HIDRAULICA  | 321-<br>322 |
|    | <b>37</b><br>FAHRERKABINE<br>CABINE<br>CABINE<br>CABINE   |             |
|    | <b>40</b><br>DEUTZ-STEUERGERÄTE<br>CONTROL UNITS, DEUTZ<br>DISTRIBUTEURS COMPLEMENTAIRES DEUTZ<br>APARTOS DE MANDO, TIPO DEUTZ                            | 323-<br>329 |
|   | <b>55</b><br>DRUCKLUFTANLAGE<br>PNEUMATIC SYSTEM<br>SYSTEME D AIR COMPRIME<br>SISTEMA DE AIRE COMPRIMINDO   | 330-<br>335 |
|  | <b>56</b><br>HYDRAULIKBREMSE FÜR ANHÄNGER<br>HYDRAULIC BRAKE FOR TRAILER<br>FREINAGE HYDRAULIQUE DE REMORQUE<br>SISTEMA DE FRENO HIDRAULICO PARA REMOLQUE |             |
|  | <b>61</b><br>BALLASTGEWICHTE HINTEN<br>BALLAST WEIGHT, REAR<br>MASSES D ALOURDISSEMENT, AR<br>PESO DE LASTRE, TRASERO                                     | 336         |
|  | <b>62</b><br>BALLASTGEWICHTE, VORNE<br>BALLAST WEIGHTS, FRONT<br>MASSES D ALOURDISSEMENT, AV<br>PESO DE LASTRE, DELANTEROS                                | 337-<br>338 |
|  | <b>81</b><br>HYDRAULIK-ZYLINDER<br>HYDRAULIC CYLINDER<br>VERIN HYDRAULIQUE<br>CILINDRO HIDRAULICO   |             |
|   |   |             |
|   |   |             |
|   |   |             |

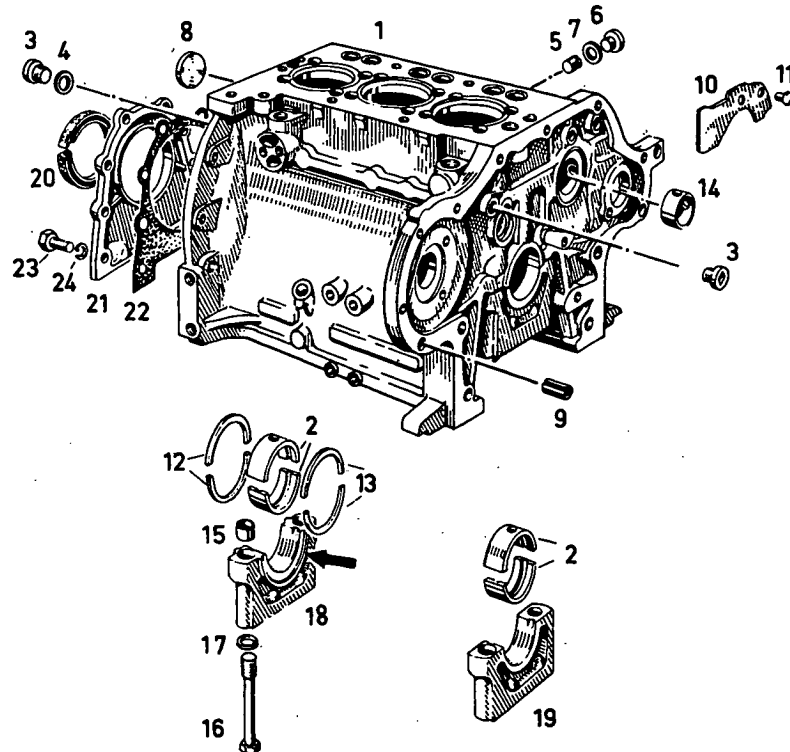
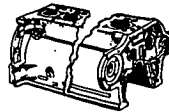

0150-01 500 6748

| Bild Nr. | Teile-Nr. | Stück-Zahl | Deutsch             | English         | Francaise          | Espanol            | Nummer/Bemerkung   | ETK |
|----------|-----------|------------|---------------------|-----------------|--------------------|--------------------|--|-----|
| 1        | 223 0526  | 1          | KURBELGEH.-OBERTEIL | CRANKCASE       | CARTER SUPERIEUR   | BLOQUE MOTOR       | BEST.AUS POS.3-11,14   |     |
| 2        | 336 2379  | 4          | KURBELWELLENLAGER   | MAIN BEARING    | PALIER LIGNE ARBRE | COJ.BANCADA        | 0150-01-27-59/63<br>NORMAL 70.00 MM RD 2.7559 IN<br>UNTERNASSTUFEN 950-955 | 03  |
| 3        | 121 4988  | 2          | VERSCHLUSSSCHRAUBE  | SCREW PLUG      | BOUCHON FILETE     | TAPON ROSCADO      | 2 827 A 3 IN KLAMMER   |     |
| 4        | 111 8707  | 2          | DICHTRING           | WASHER          | BAGUE D ETANCHEITE | ANILLO DE JUNTA    | A 16 X 22 DIN 7603-CU  |     |
| 5        | 121 5235  | 4          | SCHLITZSTÖPFEN      | SLOTTED PLUG    | BOUCHON FENDU      | TAPON RANURADO     | 860 3  |     |
| 6        | 112 2350  | 3          | VERSCHLUSSSCHRAUBE  | SCREW PLUG      | BOUCHON FILETE     | TAPON ROSCADO      | M12X1,5 DIN 908 PHOSPH   |     |
| 7        | 111 8673  | 3          | DICHTRING           | WASHER          | BAGUE D ETANCHEITE | ANILLO DE JUNTA    | A 12 X 15,5 DIN 7603-CU  |     |
| 8        | 121 6240  | 1          | VERSCHLUSSSCHEIBE   | DISHED PLUG     | RONDELLE OBTURAT.  | ARANDELA CIERRE    | 2 827 A 1  |     |
| 9        | 116 7266  | 2          | SPANNBUCHSE         | CLAMPING BUSH   | DOUILLE DE SERRAGE | CASQUILLO FIADOR   | B11X16H 2341   |     |
| 10       | 223 1082  | 1          | PRÄLLBLECH          | DEFLECTOR PLATE | CHICANE            | CHAPA DE CHOQUE    |  |     |
| 11       | 111 5333  | 2          | HALBRUNDKERBNAGEL   | NOTCHED NAIL    | ERGOT A ENCOCHE    | CLAVIJA RANURADA   | 6 X13 DIN 1476 VZKC  |     |
| 12       | 223 0181  | 1          | ANLAUFRING          | STOP RING       | BAGUE BUTEE        | ANILLO TOPE        | NORMAL 3,00 MM 0.1181 IN<br>UEBERNASSTUFEN 956-959                         | 01  |
| 13       | 223 0170  | 1          | ANLAUFRING          | STOP RING       | BAGUE BUTEE        | ANILLO TOPE        | NORMAL 3,00 MM 0.1181 IN<br>UEBERNASSTUFEN 960-963                         | 01  |
| 14       | 213 9737  | 1          | BUCHSE              | BUSH            | DOUILLE            | CASQUILLO          |  |     |
| 15       | 336 2279  | 8          | PASSBUCHSE          | DOWEL BUSH      | DOUILLE CENTRAGE   | CASQ.AJUSTE        | 0150-01-01.87  |     |
| 16       | 116 9634  | 8          | SKY-DEHNSCHRAUBE    | WAISTED BOLT    | VIS EXTENS 6 PANS  | TORN.HEX.EXPANSION | M14 X110 H 803-10.9  | 03  |
| 17       | 121 6107  | 8          | SCHIEBE             | DISC/PANE/PLATE | RONDELLE/DISQUE    | DISCO              | 2 305 A 11   |     |
| 18       | 213 8184  | 1          | LAGERDECKEL         | BEARING CAP     | CHAPEAU DE PALIER  | TAPA SOPORTE       | PASSLAGER  |     |
| 19       | 213 8185  | 3          | LAGERDECKEL         | BEARING CAP     | CHAPEAU DE PALIER  | TAPA SOPORTE       | NORMAL   |     |
| 20       | 116 0097  | 1          | WELLENDICHTRING     | SHAFT SEAL      | JOINT D ARBRE      | ANILLO HERMET.EJE  | L 115X140 X16 H 2940-SI  | 03  |
| 21       | 213 7842  | 1          | DECKEL              | COVER           | COUVERCLE          | TAPA               |  |     |

| Bld Nr. | Teil-Nr. | Stück-Zahl | Deutsch           | English           | Français           | Español            | Nummer/Bemerkung  | ETK |
|---------|----------|------------|-------------------|-------------------|--------------------|--------------------|---|-----|
| 22      | 336 2337 | 1          | DICHTUNG          | GASKET            | GARNITURE/JOINT    | JUNTA              | 0150-01-20-03   | 01  |
| 23      | 111 2322 | 8          | SECHSKANTSCHRAUBE | HEX-BOLT          | VIS 6 PANS         | TORNILLO HEXAGONAL | M 8X 20 DIN 933- 8-8-A4C                                  |     |
| 24      | 110 2799 | 8          | FEDERRING         | SPRING LOCKWASHER | RONDELLE GROMER    | ARANDELA ELASTICA  | A 8 DIN 128 A4C   |     |
| 250     | 336 2360 | 4          | KURBELWELLENLAGER | MAIN BEARING      | PALIER LIGNE ARBRE | COJ-BANCADA        | 0150-01-27-62/63<br>1-UNTERMASST-69,75 MM RD<br>2-7459 IN |     |
| 251     | 336 2361 | 4          | KURBELWELLENLAGER | MAIN BEARING      | PALIER LIGNE ARBRE | COJ-BANCADA        | 0150-01-27-64/65<br>2-UNTERMASST-69,50 MM RD<br>2-7362 IN |     |
| 252     | 336 2362 | 4          | KURBELWELLENLAGER | MAIN BEARING      | PALIER LIGNE ARBRE | COJ-BANCADA        | 0150-01-27-66/67<br>3-UNTERMASST-69,25 MM RD<br>2-7263 IN |     |
| 253     | 336 2363 | 4          | KURBELWELLENLAGER | MAIN BEARING      | PALIER LIGNE ARBRE | COJ-BANCADA        | 0150-01-27-68/69<br>4-UNTERMASST-69,00 MM RD<br>2-7165 IN |     |
| 254     | 336 2364 | 4          | KURBELWELLENLAGER | MAIN BEARING      | PALIER LIGNE ARBRE | COJ-BANCADA        | 0150-01-27-70/72<br>5-UNTERMASST-68,75 MM RD<br>2-7066 IN |     |
| 255     | 336 2365 | 4          | KURBELWELLENLAGER | MAIN BEARING      | PALIER LIGNE ARBRE | COJ-BANCADA        | 0150-01-27-73/74<br>6-UNTERMASST-68,50 MM RD<br>2-6968 IN |     |
| 256     | 223 0182 | 1          | ANLAUFRING        | STOP RING         | BAGUE BUTEE        | ANILLO TOPE        | 1-UEBERMASST-3,25 MM<br>0-1279 IN                         |     |
| 257     | 223 0183 | 1          | ANLAUFRING        | STOP RING         | BAGUE BUTEE        | ANILLO TOPE        | 2-UEBERMASST-3,50 MM<br>0-1378 IN                         |     |
| 258     | 223 0184 | 1          | ANLAUFRING        | STOP RING         | BAGUE BUTEE        | ANILLO TOPE        | 3-UEBERMASST-3,75 MM<br>0-1476 IN                         |     |
| 259     | 223 0185 | 1          | ANLAUFRING        | STOP RING         | BAGUE BUTEE        | ANILLO TOPE        | 4-UEBERMASST-4,00 MM<br>0-1575 IN                         |     |
| 260     | 223 0172 | 1          | ANLAUFRING        | STOP RING         | BAGUE BUTEE        | ANILLO TOPE        | 1-UEBERMASST-3,25 MM<br>0-1279 IN                         |     |
| 261     | 223 0173 | 1          | ANLAUFRING        | STOP RING         | BAGUE BUTEE        | ANILLO TOPE        | 2-UEBERMASST-3,50 MM<br>0-1378 IN                         |     |
| 262     | 223 0174 | 1          | ANLAUFRING        | STOP RING         | BAGUE BUTEE        | ANILLO TOPE        | 3-UEBERMASST-3,75 MM<br>0-1476 IN                         |     |
| 263     | 223 0175 | 1          | ANLAUFRING        | STOP RING         | BAGUE BUTEE        | ANILLO TOPE        | 4-UEBERMASST-4,00 MM<br>0-1575 IN                         |     |

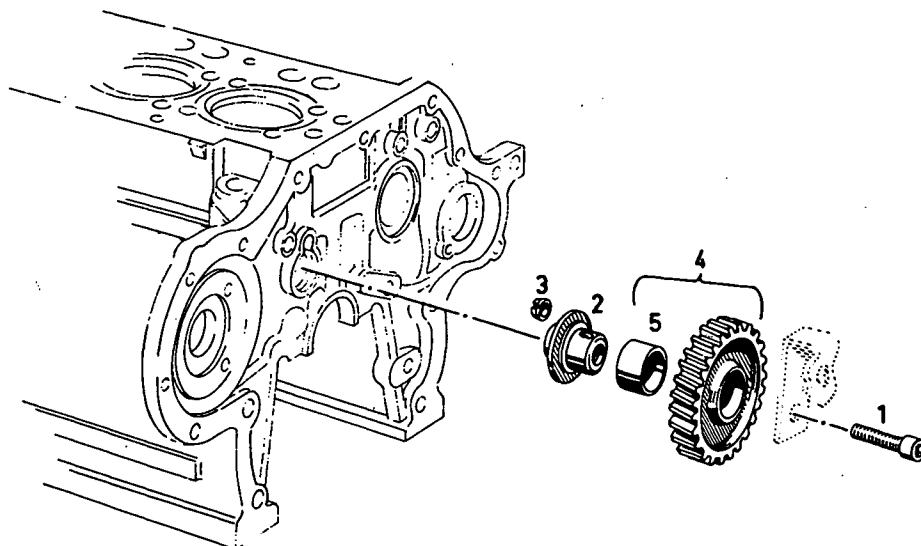
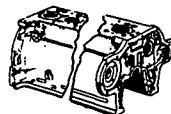

0150-01 500 6503

| Bild Nr. | Teil-Nr. | Stück-Zahl | Deutsch          | English           | Français           | Español           | Nummer/Bemerkung        | ETK |
|----------|----------|------------|------------------|-------------------|--------------------|-------------------|-------------------------|-----|
| 1        | 111 0688 | 1          | ZYLINDERSCHRAUBE | CHEESE-HEAD SCREW | VIS TETE CYLINDR.  | TORN-CAZA-CILIND. | M10X 60DIN 912-10-7-A4C |     |
| 2        | 210 1006 | 1          | LAGERZAPFEN      | JOURNAL           | TOURILLON/MANETON  | MUNON SOPORTE     | 0150-31-45-08           |     |
| 3        | 210 1007 | 1          | BUCHSE           | BUSH              | DOUILLE            | CASQUILLO         | 0150-31-45-09           |     |
| 4        | 336 2541 | 1          | ZWISCHENRAD      | IDLER GEAR        | ROUE INTERMEDIAIRE | RUEDA INTERMEDIA  | 0150-01-74-20           |     |
| 5        | 336 2538 | 1          | BUECHSE          | BUSH              | BOITE              | CASQUILLO         | 0150-31-74-02           |     |

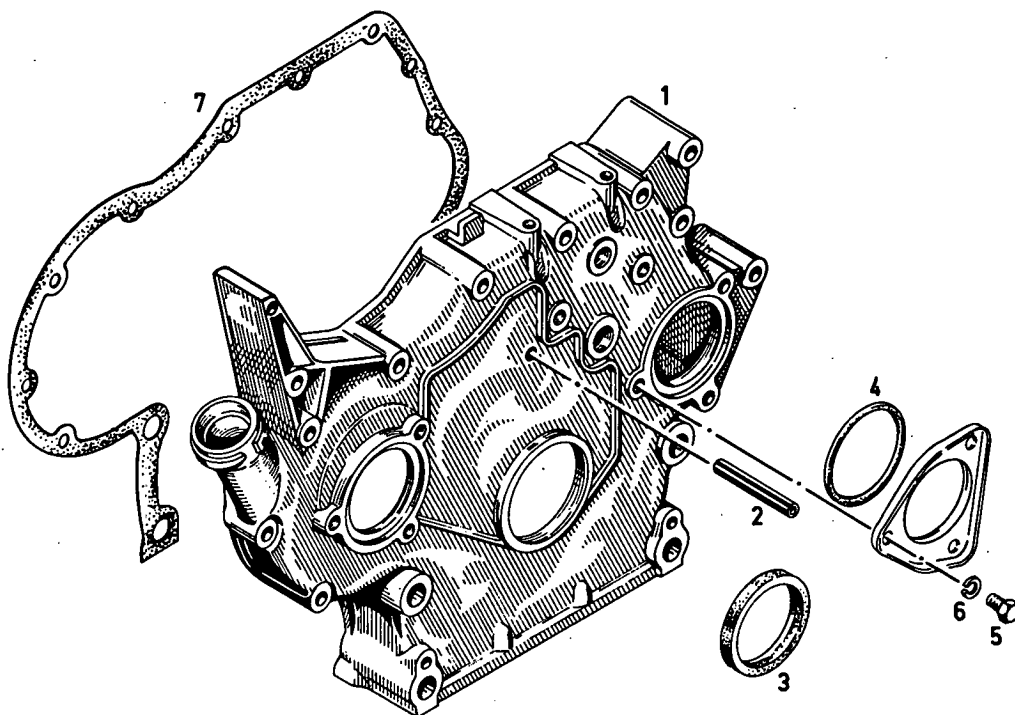
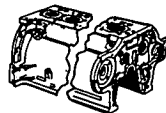

0150-01 500 4555

| Bild Nr. | Teile-Nr. | Stück-Zahl | Deutsch           | English           | Français        | Español            | Nummer/Bemerkung          | ETK |
|----------|-----------|------------|-------------------|-------------------|-----------------|--------------------|---------------------------|-----|
| 1.       | 213 6027  | 1          | VORDERER-DECKEL   | FRONT COVER       | COUVERCLE AV    | TAPA DELANTERA     |                           |     |
| 2.       | 111 5459  | 1          | SPANNHUELSE       | DOWEL SLEEVE      | DOUILLE SERRAGE | CASQUILLO FIADOR   | 6 X 45 DIN 1481           |     |
| 3.       | 213 3781  | 1          | WELLENDICHRING    | SHAFT SEAL        | JOINT D ARBRE   | ANILLO HERMET-EJE  |                           | 01  |
| 4.       | 116 6110  | 1          | RUNDGUMRING       | O-SEAL            | ANNEAU TORIQUE  | ANILLO GOMA REDOND | 80 X 3 H 721              |     |
| 5.       | 111 2295  | 1          | SECHSKANTSCHRAUBE | HEX-BOLT          | VIS 6 PANS      | TORNILLO HEXAGONAL | M 8 X 10 DIN 933- 8.8-A4C |     |
| 6.       | 110 2799  | 1          | FEDERRING         | SPRING LOCKWASHER | RONDELLE GROUER | ARANDELA ELASTICA  | A 8 DIN 128 A4C           |     |
| 7.       | 336 2505  | 1          | DICHTUNG          | GASKET            | GARNITURE/JOINT | JUNTA              | 0150-01-54-12             | 01  |

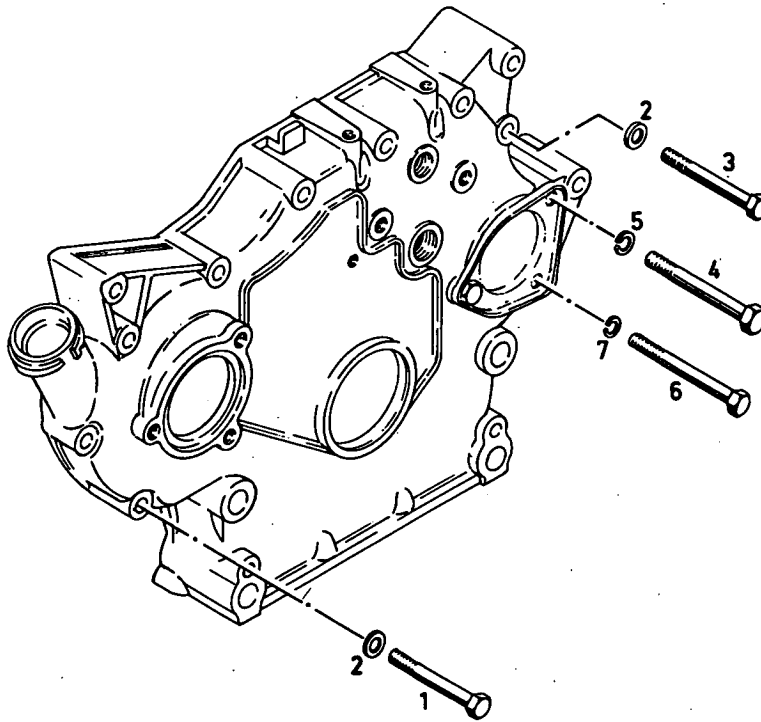

0150-01 500 6842

| Bild Nr. | Teile-Nr. | Stück-Zahl | Deutsch           | English           | Français        | Español            | Nummer/Bemerkung         | ETK |
|----------|-----------|------------|-------------------|-------------------|-----------------|--------------------|--------------------------|-----|
| 1        | 111 1166  | 2          | SECHSKANTSCHRAUBE | HEX-BOLT          | VIS 6 PANS      | TORNILLO HEXAGONAL | M 8X 60 DIN 931- 8-8     |     |
| 2        | 110 7101  | 3          | SCHEIBE           | DISC/PANE/PLATE   | RONDELLE/DISQUE | DISCO              | A 8-4DIN 125-ST-A4C      |     |
| 3        | 111 1179  | 1          | SECHSKANTSCHRAUBE | HEX-BOLT          | VIS 6 PANS      | TORNILLO HEXAGONAL | M 8X 70 DIN 931- 8-8-A4C |     |
| 4        | 111 1334  | 1          | SECHSKANTSCHRAUBE | HEX-BOLT          | VIS 6 PANS      | TORNILLO HEXAGONAL | M10X 75 DIN 931- 8-8     |     |
| 5        | 110 2800  | 1          | FEDERRING         | SPRING LOCKWASHER | RONDELLE GROUER | ARANDELA ELASTICA  | A 10 DIN 128 A4C         |     |
| 6        | 111 1195  | 1          | SECHSKANTSCHRAUBE | HEX-BOLT          | VIS 6 PANS      | TORNILLO HEXAGONAL | M 8X 55 DIN 931- 8-8     |     |
| 7        | 110 2799  | 1          | FEDERRING         | SPRING LOCKWASHER | RONDELLE GROUER | ARANDELA ELASTICA  | A 8 DIN 128 A4C          |     |



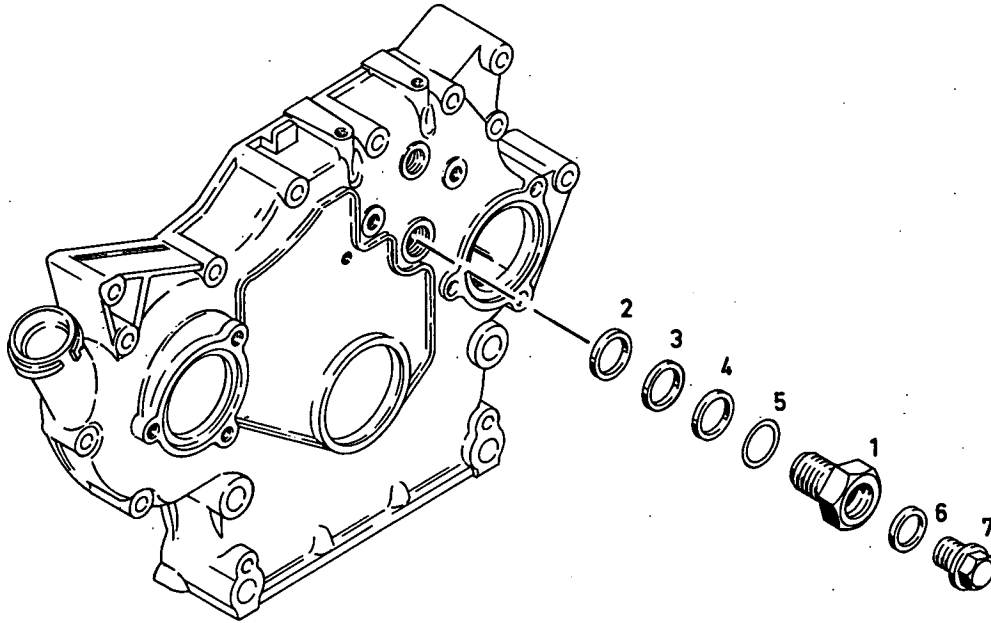
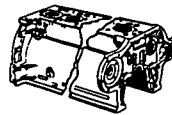

0150-01 500 3307

| Bld Nr. | Teile-Nr. | Stück-Zahl | Deutsch            | English         | Français           | Español         | Nummer/Bemerkung       | ETK |
|---------|-----------|------------|--------------------|-----------------|--------------------|-----------------|------------------------|-----|
| 1       | 336 2530  | 1          | VERSCHLUSSSCHRAUBE | SCREW PLUG      | BOUCHON FILETE     | TAPON ROSCADO   | 0150-01-62-03          |     |
| 2       | 111 8750  | 1          | DICHRING           | WASHER          | BAGUE D ETANCHEITE | ANILLO DE JUNTA | A 24 X 30 DIN 7603-ALU |     |
| 3       | 336 2293  | 1          | SCHWEIBE           | DISC/PANE/PLATE | RONDELLE/DISQUE    | DISCO           | 0150-01-07-08          |     |
| 4       | 336 2294  | 1          | SCHWEIBE           | DISC/PANE/PLATE | RONDELLE/DISQUE    | DISCO           | 0150-01-07-09          |     |
| 5       | 336 2295  | 2          | SCHWEIBE           | DISC/PANE/PLATE | RONDELLE/DISQUE    | DISCO           | 0150-01-07-11          |     |
| 6       | 111 8713  | 1          | DICHRING           | WASHER          | BAGUE D ETANCHEITE | ANILLO DE JUNTA | A 18 X 22 DIN 7603-CU  |     |
| 7       | 111 8770  | 1          | VERSCHLUSSSCHRAUBE | SCREW PLUG      | BOUCHON FILETE     | TAPON ROSCADO   | M18X1,5 DIN 7604       |     |

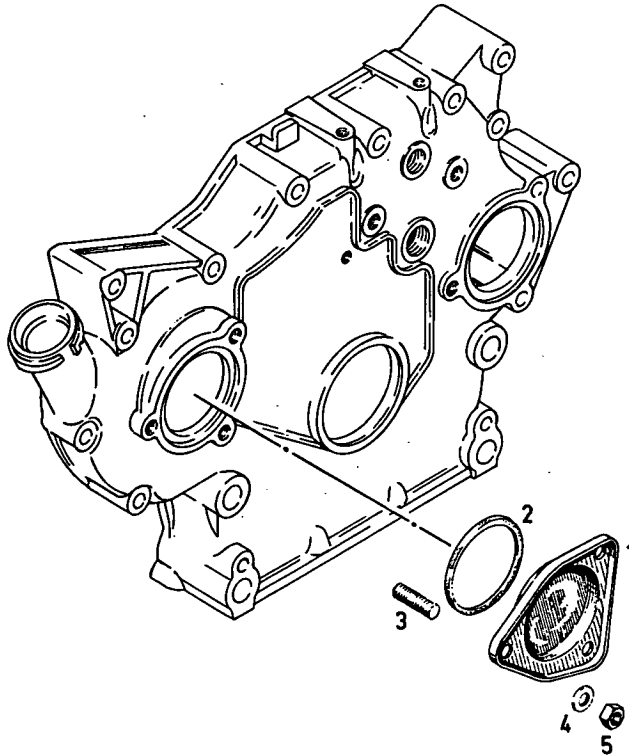
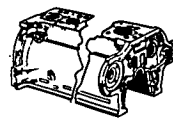

0150-01 500 3331

| Bild Nr. | Teile-Nr. | Stück-Zahl | Deutsch         | English         | Français        | Español            | Nummer/Bemerkung                  | ETK |
|----------|-----------|------------|-----------------|-----------------|-----------------|--------------------|-----------------------------------|-----|
| 1        | 336 2504  | 1          | DECKEL          | COVER           | COUVERCLE       | TAPA               | 0150-01-500 05                    |     |
| 2        | 116 6110  | 1          | RUNDGUMRING     | O-SEAL          | ANNEAU TORIQUE  | ANILLO GOMA REDOND | 80 X 3 H 721                      |     |
| 3        | 110 2295  | 3          | STIFTSCHRAUBE   | STUD            | GOIJON          | ESPARRAGO          | M 8 X 1,5 S N 4 DIN 835- 6-8 VZKC |     |
| 4        | 110 7101  | 3          | SCHIEBE         | DISC/PANE/PLATE | RONDELLE/DISQUE | DISCO              | A 8-NDIN 125-ST-A9C               |     |
| 5        | 111 2824  | 3          | SECHSKANTMUTTER | HEX-NUT         | ECROU 6 PANS    | TUERCA HEXAGONAL   | M 8 DIN 934-M 8 A9C               |     |

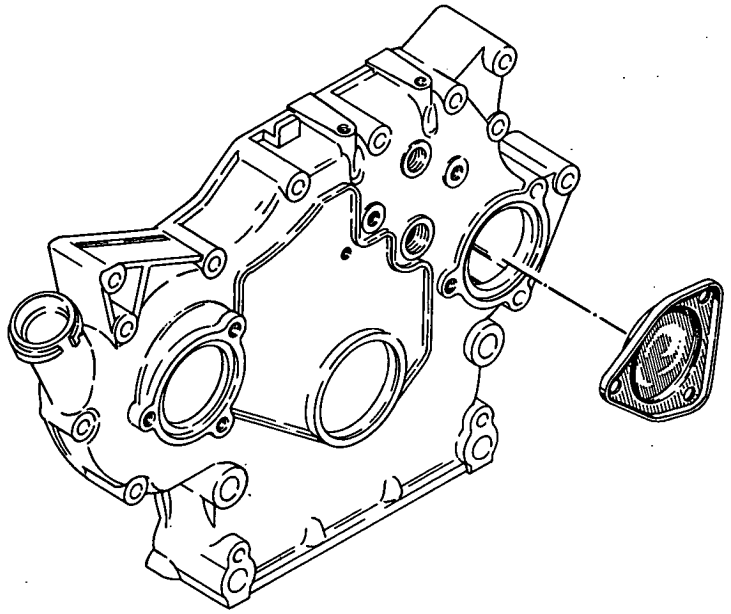
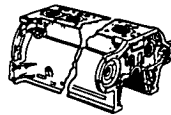

0150-01 500 3326

| Bild Nr. | Teile-Nr. | Stück-Zahl | Deutsch | English | Français  | Español | Nummer/Bemerkung | ETK |
|----------|-----------|------------|---------|---------|-----------|---------|------------------|-----|
| 1        | 336 2504  | 1          | BECKEL  | COVER   | COUVERCLE | TAPA    |                  |     |

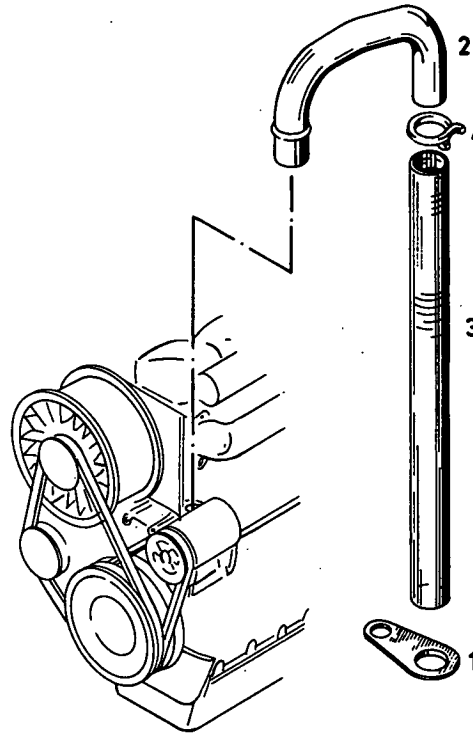
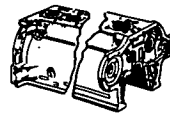

0150-01 500 3333

| Bild Nr. | Teil-Nr. | Stück-Zahl | Deutsch            | English         | Français           | Español           | Nummer/Bemerkung | ETK |
|----------|----------|------------|--------------------|-----------------|--------------------|-------------------|------------------|-----|
| 1        | 210 1292 | 1          | HALTEBLECH         | RETAINING PLATE | TOLE DE RETENUE    | CHAPA SUJECION    | 0150-01-416-04   |     |
| 2        | 210 1937 | 1          | ROHR               | PIPE/TUBE       | TUBE/TUYAU         | TUBO              | 0150-01-416-01   |     |
| 3        | 190 0762 | 1          | KUNSTSTOFFSCHLAUCH | PLASTIC HOSE    | BOYAU PLASTIQUE    | MANGUERA PLASTICO | A25X31X340 H7761 |     |
| 4        | 116 3942 | 1          | SCHLAUCHKLEMME     | HOSE CLIP       | COLLIER A FLEXIBLE | PINZA MANGUERA    | SK 33 H 735      |     |

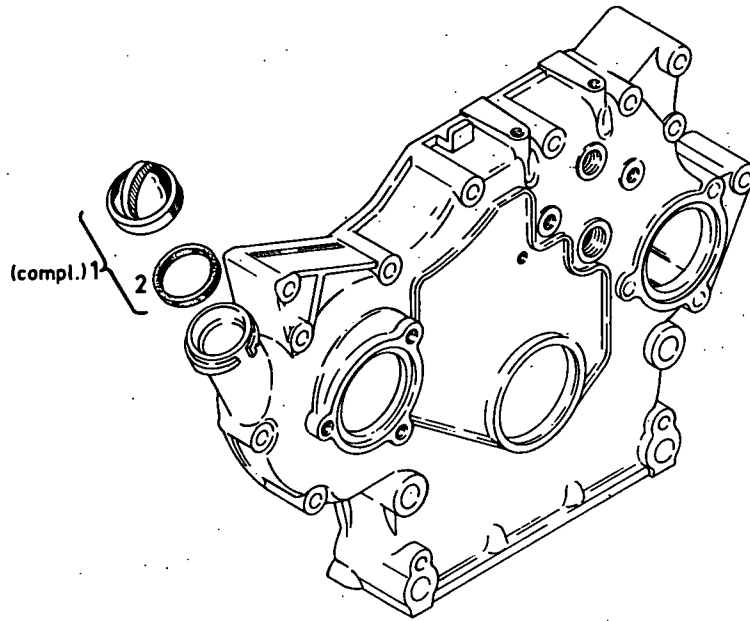
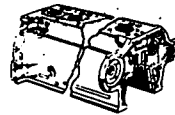

0150-01 500 3320

| Bild Nr. | Teile-Nr. | Stück-Zahl | Deutsch   | English | Français           | Español         | Nummer/Bemerkung | ETK |
|----------|-----------|------------|-----------|---------|--------------------|-----------------|------------------|-----|
| 1        | 123 6291  | 1          | BECKEL    | COVER   | COUVERCLE          | TAPA            | 8928-75-007-010  |     |
| 2        | 123 6290  | 1          | DICHTRING | WASHER  | BAGUE D ETANCHEITE | ANILLO DE JUNTA | 8928-75-007-002  | 03  |



Ölmeßstab  
 Oil dipstick  
 Jauge de niveau d'huile  
 Varilla de sondeo para nivel de aceite

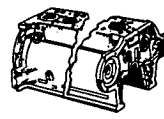

0150-01-500 4439

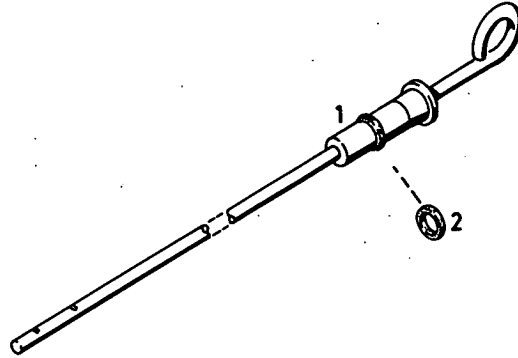

0150-01 500 4439

| Bild Nr. | Teil-Nr. | Stück-Zahl | Deutsch       | English      | Français       | Español                        | Nummer/Bemerkung                 | ETK |
|----------|----------|------------|---------------|--------------|----------------|--------------------------------|----------------------------------|-----|
| 1        | 336 2498 | 1          | ÖLMESSSTAB    | OIL DIPSTICK | JAUGE D HUILE  | VARIL-NIVEL ACEITE             | 0150-01-52-280<br>MIT BILD-NR. 2 |     |
| 2        | 116 5975 | 1          | RUNDGUMMIRING | O-SEAL       | ANNEAU TORIQUE | ANILLO GOMA REDOND 5 X 8 H 721 |                                  | 01  |



Verschlußteile  
 Locking parts  
 Pièces de fermeture  
 Partes de cierre

Stück/Zyl.-Einheit  
 Pieces / cyl. unit  
 Qté / cylindre  
 Cantid. / unid. cilind.

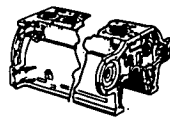

0150-01-500 6781

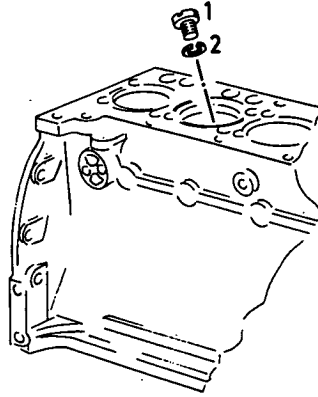

0150-01 500 6781

| Bild-Nr. | Teil-Nr. | Stück-Zahl | Deutsch           | English           | Français        | Español           | Nummer/Bemerkung | ETK |
|----------|----------|------------|-------------------|-------------------|-----------------|-------------------|------------------|-----|
| 1        | 213 0507 | 1          | VERSCHLUSSSTÖPFEN | NIPPLE            | BOUCHON         | TAPON OBTURADOR   |                  |     |
| 2        | 111 7611 | 1          | FEDERRING         | SPRING LOCKWASHER | RONDELLE GROMER | ARANDELA ELASTICA | 8DIN 7980 VZKC   |     |

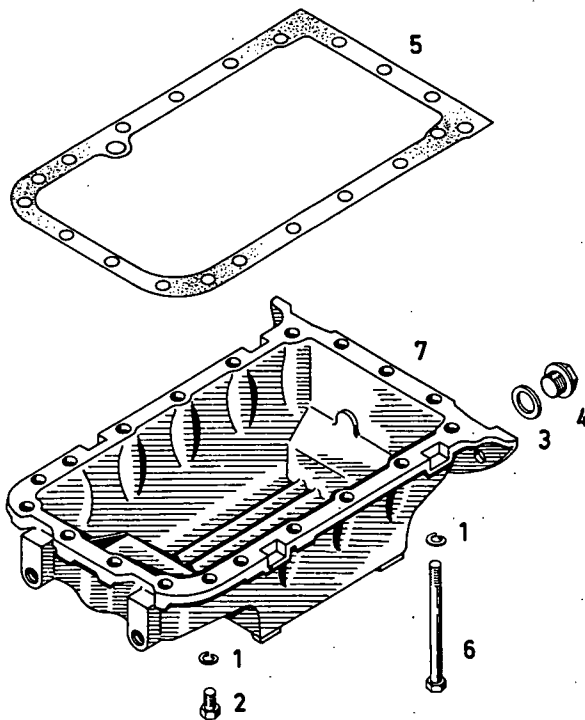
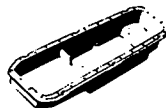

0150-02 500 6732

| Bild Nr. | Teil-Nr. | Stück-Zahl | Deutsch            | English           | Français           | Español            | Nummer/Bemerkung          | ETK |
|----------|----------|------------|--------------------|-------------------|--------------------|--------------------|---------------------------|-----|
| 1        | 110 2799 | 19         | FEDERRING          | SPRING LOCKWASHER | RONDELLE GROUPE    | ARANDELA ELASTICA  | A 8 DIN 128 A4C           |     |
| 2        | 111 2333 | 16         | SECHSKANTSCHRAUBE  | HEX-BOLT          | VIS 6 PANS         | TORNILLO HEXAGONAL | M 8 X 25 DIN 933- 8-8-A4C |     |
| 3        | 111 8736 | 1          | DICHRING           | WASHER            | BAGUE D ETANCHEITE | ANILLO DE JUNTA    | A 22 X 27 DIN 7603-ALU    | 01  |
| 4        | 111 8780 | 1          | VERSCHLUSSSCHRAUBE | SCREW PLUG        | BOUCHON FILETE     | TAPON ROSCADO      | M22X1,5 DIN 7604 VZKC     | 01  |
| 5        | 336 2573 | 1          | DICHTUNG           | GASKET            | GARNITURE/JOINT    | JUNTA              | 0150-02-01-02             | 01  |
| 6        | 111 1212 | 3          | SECHSKANTSCHRAUBE  | HEX-BOLT          | VIS 6 PANS         | TORNILLO HEXAGONAL | M 8 X 110 DIN 933- 8-8    |     |
| 7        | 213 1611 | 1          | ÖELWANNE           | OIL SUMP          | CUVE A HUILE       | SUMIDERO ACEITE    |                           |     |



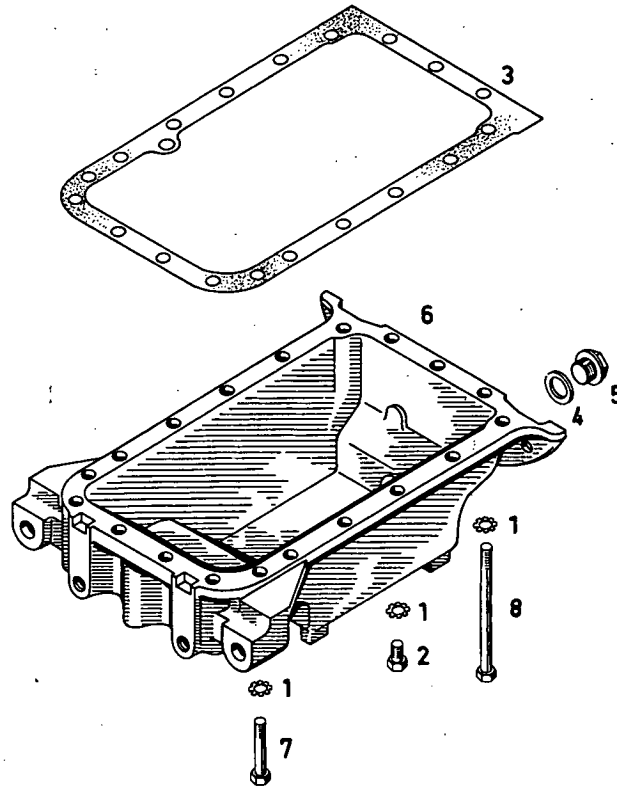
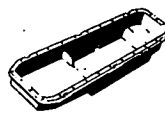

0150-02 500 6742

| Bild-Nr. | Teile-Nr. | Stück-Zahl | Deutsch            | English        | Français           | Español            | Nummer/Bemerkung       | ETK |
|----------|-----------|------------|--------------------|----------------|--------------------|--------------------|------------------------|-----|
| 1        | 110 1492  | 19         | ZAHNSCHEIBE        | TOOTHED WASHER | RONDELLE DENTÉE    | ARANDELA DENTADA   | A 8-20IN 6797          |     |
| 2        | 111 2339  | 12         | SECHSKANTSCHRAUBE  | HEX-BOLT       | VIS 6 PANS         | TORNILLO HEXAGONAL | M 8 X 30 DIN 933- 8-8  |     |
| 3        | 336 2573  | 1          | DICHTUNG           | GASKET         | GARNITURE/JOINT    | JUNTA              | 0150-02-01-02          | 03  |
| 4        | 111 8783  | 1          | DICHRING           | WASHER         | BAGUE D ETANCHEITE | ANILLO DE JUNTA    | A 30 X 36 DIN 7603-ALU | 03  |
| 5        | 111 8789  | 1          | VERSCHLUSSSCHRAUBE | SCREW PLUG     | BOUCHON FILETE     | TAPON ROSCADO      | AM30X1,5 DIN 7604 VZKC | 03  |
| 6        | 210 1390  | 1          | ÖLWANNE            | OIL SUMP       | CUVE A HUILE       | SUMIDERO ACEITE    | 0150-02-18-26          |     |
| 7        | 111 1151  | 2          | SECHSKANTSCHRAUBE  | HEX-BOLT       | VIS 6 PANS         | TORNILLO HEXAGONAL | M 8 X 45 DIN 931- 8-8  |     |
| 8        | 111 1212  | 5          | SECHSKANTSCHRAUBE  | HEX-BOLT       | VIS 6 PANS         | TORNILLO HEXAGONAL | M 8 X 110 DIN 931- 8-8 |     |

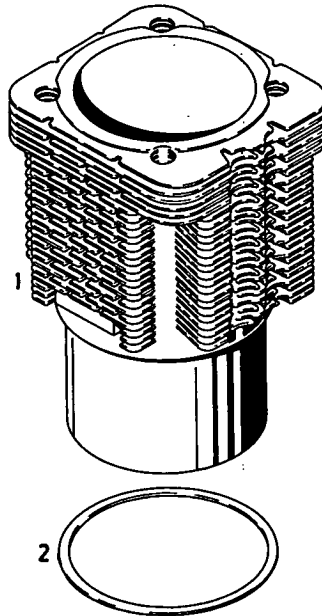

0150-04 500 3353

| Bild Nr. | Teile-Nr. | Stück-Zahl | Deutsch       | English      | Français         | Español          | Nummer/Bemerkung                          | ETK |
|----------|-----------|------------|---------------|--------------|------------------|------------------|---|-----|
| 1        | 223 1924  | 1          | ZYLINDER      | CYLINDER/RAH | CYLINDRE         | CILINDRO         | 100-80MMR0 3-9370IN-<br>WAHLWEISE POS-950 | 01  |
| 2        | 223 1844  | NB         | AUSGLEICHRING | SHIM         | ANNEAU COMPENSAT | ARO COMPENSACION |   | 01  |
| 950      | 223 1975  | 1          | ZYLINDER      | CYLINDER/RAH | CYLINDRE         | CILINDRO         | WAHLWEISE POS-1                           |     |

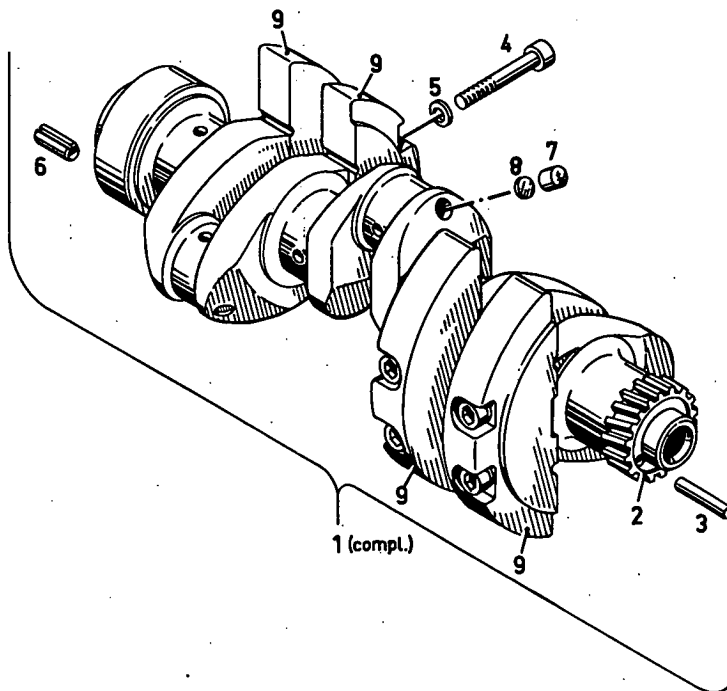

0150-05 500 6730

| Bild Nr. | Teil-Nr. | Stück-Zahl | Deutsch          | English           | Français          | Español           | Nummer/Bemerkung                       | ETK |
|----------|----------|------------|------------------|-------------------|-------------------|-------------------|--|-----|
| 1        | 213 6926 | 1          | KURBELWELLE      | CRANKSHAFT        | VILEBREQUIN       | CIGUENAL          | TESTIERTE KURBELWELLEN<br>POS. 950-955 |     |
| 2        | 336-2737 | 1          | ZAHNRAD          | GEAR              | ROUE DENTEE       | RUEDA DENTADA     | D150-35-36-34                          |     |
| 3        | 110 5166 | 1          | ZYLINDERSTIFT    | PARALLEL PIN      | GOUVILLE CYLINDR. | PERNO CILINDRICO  | 8 M 6X 450IN 7                         |     |
| 4        | 112 4778 | 8          | ZYLINDERSCHRAUBE | CHEESE-HEAD SCREW | VIS TETE CYLINDR. | TORN-CBZA-CILIND. | M12X 60DIN 932-30.9 A4C                |     |
| 5        | 121 6119 | 8          | SCHEIBE          | DISC/PANE/PLATE   | RONDELLE/DISQUE   | DISCO             | 2 305 A 29                             |     |
| 6        | 111 5464 | 1          | SPANNHUELSE      | DOWEL SLEEVE      | DOUILLE SERRAGE   | CASQUILLO FIADOR  | 8 X 33DIN 1481                         |     |
| 7        | 117 0580 | 3          | STOPFEN          | PLUG              | BOUCHON           | TAPON             | A 8 H 2855                             |     |
| 8        | 116 7010 | 3          | SCHEIBE          | DISC/PANE/PLATE   | RONDELLE/DISQUE   | DISCO             | A 7.5X 1 H 984                         |     |
| 9        | 223 0134 | 4          | GEGENGEWICHT     | COUNTERWEIGHT     | CONTRE-POIDS      | CONTRAPESO        |  |     |
| 950      | 213 7737 | NB         | KURBELWELLE      | CRANKSHAFT        | VILEBREQUIN       | CIGUENAL          | TEST SL                                |     |
| 951      | 213 7738 | NB         | KURBELWELLE      | CRANKSHAFT        | VILEBREQUIN       | CIGUENAL          | TEST LR                                |     |
| 952      | 223 0634 | NB         | KURBELWELLE      | CRANKSHAFT        | VILEBREQUIN       | CIGUENAL          | TEST BV                                |     |
| 953      | 223 0635 | NB         | KURBELWELLE      | CRANKSHAFT        | VILEBREQUIN       | CIGUENAL          | TEST WV                                |     |
| 954      | 223 0636 | NB         | KURBELWELLE      | CRANKSHAFT        | VILEBREQUIN       | CIGUENAL          | TEST YIN                               |     |
| 955      | 223 0637 | NB         | KURBELWELLE      | CRANKSHAFT        | VILEBREQUIN       | CIGUENAL          | TEST ABS                               |     |

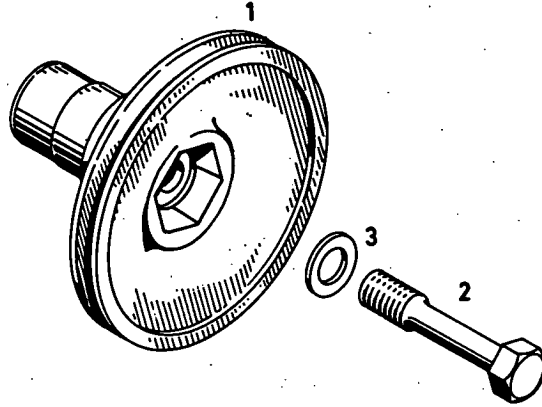

0150-05 500 4551

| Bild-Nr. | Teil-Nr. | Stück-Zahl | Deutsch            | English         | Français          | Español            | Nummer/Bemerkung           | ETK |
|----------|----------|------------|--------------------|-----------------|-------------------|--------------------|----------------------------|-----|
| 1        | 213 4337 | 1          | KEILRIEMENSCHLEIBE | V-BELT PULLEY   | POULIE COURR TRAP | POLEA ACANALADA    |                            |     |
| 2        | 116 6951 | 1          | SKT-DEHNSCHRAUBE   | WAISTED BOLT    | VIS EXTENS L PANS | TORN-HEX-EXPANSION | M24X2 LINKSXL10 H 803-10-9 |     |
| 3        | 121 6128 | 1          | SCHLEIBE           | DISC/PANE/PLATE | RONDELLE/DISQUE   | DISCO              | 2 305 A 90                 |     |



Schwungrad  
Flywheel  
Volant  
Volante



0150-05-500 6805

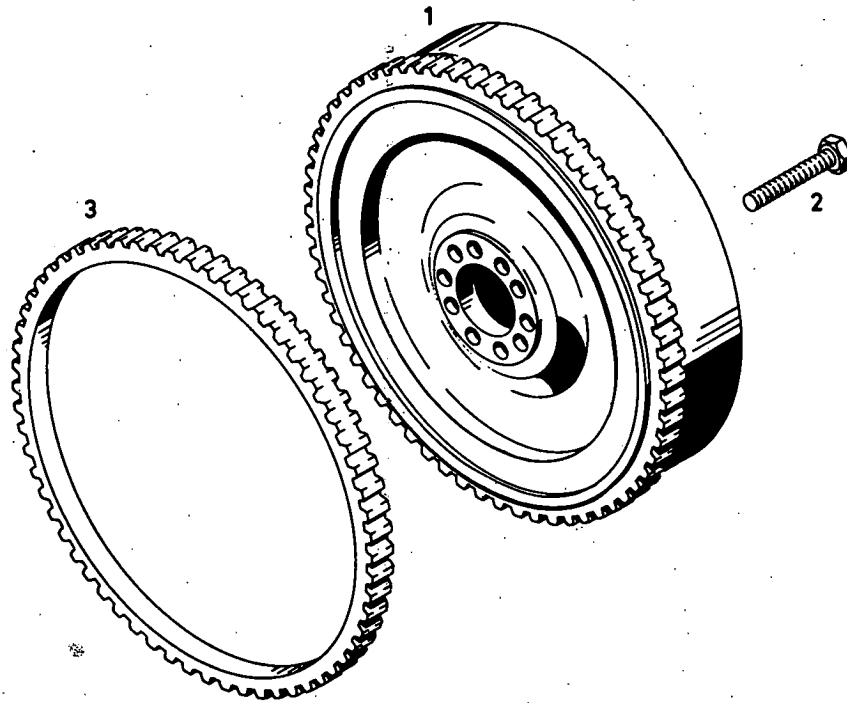

0150-05 500 6805

| Bild Nr. | Teile-Nr. | Stück-Zahl | Deutsch           | English   | Français        | Español            | Nummer/Bemerkung            | ETK |
|----------|-----------|------------|-------------------|-----------|-----------------|--------------------|-----------------------------|-----|
| 1        | 216 2477  | 1          | SCHWUNGRAD        | FLYWHEEL  | VOLANT          | VOLANTE            |                             |     |
| 2        | 110 4845  | 10         | SECHSKANTSCHRAUBE | HEX-BOLT  | VIS 6 PANS      | TORNILLO HEXAGONAL | M10X1 X 35 DIN 913-10-7-A9C |     |
| 3        | 213 1081  | 1          | ZAHNKRANZ         | RING GEAR | COURONNE DENTEE | CORONA DENTADA     |                             |     |



Pleuelstange  
Connecting rod  
Bielle  
Biela

Stück / Zyl.-Einheit  
Pieces / cyl. unit  
Qté / cylindre  
Cantid./unid. cilind.



0150-06-500 4310

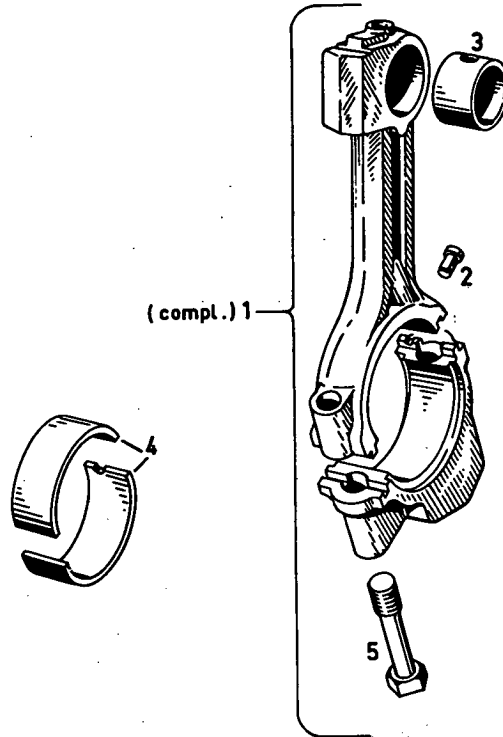

0150-06 500 4310

| Bild Nr. | Teile-Nr. | Stück-Zahl | Deutsch           | English         | Français          | Español            | Nummer/Bemerkung   | ETK |
|----------|-----------|------------|-------------------|-----------------|-------------------|--------------------|--|-----|
| 1        | 213 6526  | 1          | PLEUELSTANGE      | CONNECTING ROD  | BIELLE            | BIELA              |  |     |
| 2        | 213 6101  | 1          | STIFT             | PIN             | CHEVILLE/GOUPILLE | PERNO/PASADOR      |  | 01  |
| 3        | 337 1612  | 1          | KOLBENBUCHSE      | BARREL          | CYL DE PLONGEUR   | CASQ-ENBOLO/PISTON | 0155-06-05-05  | 01  |
| 4        | 213 7750  | 1          | PLEUELLAGER       | BIG-END BEARING | COUSS TETE BIELLE | COJINETE BIELA     | NORMAL 60,00MM RD 2,3622 IN.<br>UNTERMASST.-POS.-750-755 | 01  |
| 5        | 213 3871  | 2          | SKT.-DEHNSCHRAUBE | WAISTED BOLT    | VIS EXTENS 6 PANS | TORN-HEX-EXPANSION |  | 01  |
| 50       | 213 7754  | NB         | PLEUELLAGER       | BIG-END BEARING | COUSS TETE BIELLE | COJINETE BIELA     | 1. UNTERMASST.-59,75MM RD<br>2,3523 IN.                  |     |
| 51       | 213 7756  | NB         | PLEUELLAGER       | BIG-END BEARING | COUSS TETE BIELLE | COJINETE BIELA     | 2. UNTERMASST.-59,50MM RD<br>2,3425 IN.                  |     |
| 52       | 213 7762  | NB         | PLEUELLAGER       | BIG-END BEARING | COUSS TETE BIELLE | COJINETE BIELA     | 3. UNTERMASST.-59,25MM RD<br>2,3327 IN.                  |     |
| 53       | 213 7766  | NB         | PLEUELLAGER       | BIG-END BEARING | COUSS TETE BIELLE | COJINETE BIELA     | 4. UNTERMASST.-59,00MM RD<br>2,3228 IN.                  |     |
| 54       | 213 7770  | NB         | PLEUELLAGER       | BIG-END BEARING | COUSS TETE BIELLE | COJINETE BIELA     | 5. UNTERMASST.-58,75MM RD<br>2,3130 IN.                  |     |
| 55       | 213 7774  | NB         | PLEUELLAGER       | BIG-END BEARING | COUSS TETE BIELLE | COJINETE BIELA     | 6. UNTERMASST.-58,50MM RD<br>2,3031 IN.                  |     |

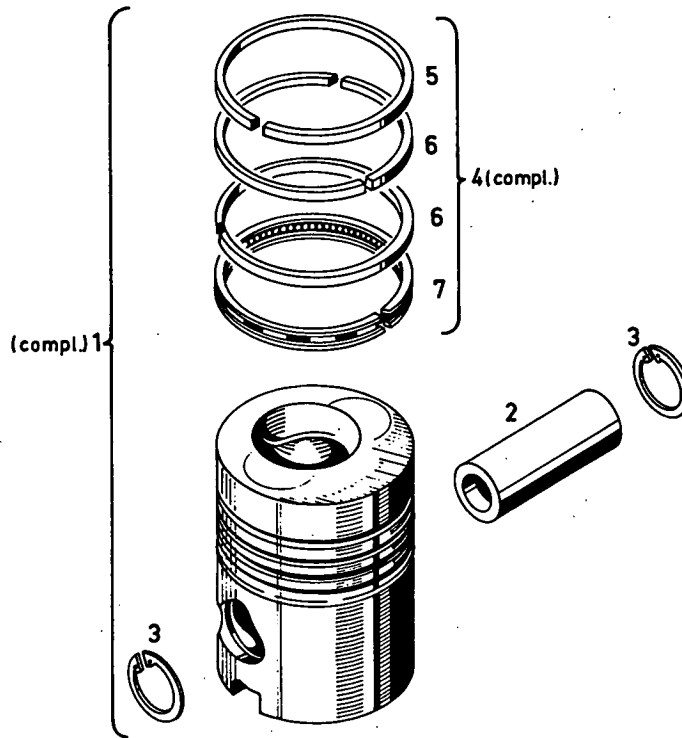

0150-07 500 3387

| Bild Nr. | Teil-Nr. | Stück-Zahl | Deutsch        | English           | Français           | Español           | Nummer/Bemerkung   | ETK |
|----------|----------|------------|----------------|-------------------|--------------------|-------------------|--|-----|
| 1        | 213 6952 | 1          | KOLBEN         | PISTON/PLUNGER    | PISTON             | EMBOLO/PISTON     | NORMAL 100,00MM RD 3,9370IN.<br>UEBERNASSTUFEN POS.950 U.955                               | 01  |
| 2        | 337 1660 | 1          | KOLBENBOLZEN   | PISTON PIN        | AXE DE PISTON      | PERNO DE EMBOLO   | 0155-07-10-22  |     |
| 3        | 110 7821 | 2          | SICHERUNGSRING | CIRCLIP           | CIRCLIP            | CIRCLIP           | 35X1,5-DIN 472   |     |
| 4        | 213 3809 | SZ         | KOLBENRING     | PISTON RING       | SEGMENT PISTON     | ARO EMBOLO/PISTON | NORMAL 100,00MM RD 3,9370IN.<br>UEBERNASSTUFEN POS.951 U.956                               | 01  |
| 5        | 116 2303 | 1          | TRAPEZRING     | TRAPEZOIDAL RING  | SEGMENT TRAPEZ.    | ANIL-SECC-TRAPEC. | D 100 X 91,4X3 H 2962 K-CR<br>NORMAL 100,00MM RD 3,9370IN.<br>UEBERNASSTUFEN POS.952 U.957 |     |
| 6        | 116 1084 | 2          | MINUTENRING    | TAPER PISTON RING | SEGM BISEAUTE      | ARO BISELADO      | 100 X 91,4X 2,5H 2959 FE<br>NORMAL 100,00MM RD 3,9370IN.<br>UEBERNASSTUFEN POS.953 U.958   |     |
| 7        | 116 1089 | 1          | OELSCHLITZRING | OIL CONTROL RING  | SEG RACL HLE A LUM | AN-RANUR-RASPACTE | SF 100 X 90,9X 5 H 2984 CR<br>NORMAL 100,00MM RD 3,9370IN.<br>UEBERNASSTUFEN POS.954 U.959 |     |
| 950      | 213 6958 | 1          | KOLBEN         | PISTON/PLUNGER    | PISTON             | EMBOLO/PISTON     | 1.UEBERNASSTUFE 100,50 MM RD<br>3,9567 IN.   |     |
| 951      | 223 0292 | SZ         | KOLBENRING     | PISTON RING       | SEGMENT PISTON     | ARO EMBOLO/PISTON | 1.UEBERNASSTUFE 100,50 MM RD<br>3,9567IN.  |     |
| 952      | 116 2469 | 1          | TRAPEZRING     | TRAPEZOIDAL RING  | SEGMENT TRAPEZ.    | ANIL-SECC-TRAPEC. | D 100,5X 91,9X3 H 2962 K-CR<br>1.UEBERNASSTUFE 100,50 MM RD<br>3,9567 IN.                  |     |
| 953      | 116 2104 | 2          | MINUTENRING    | TAPER PISTON RING | SEGM BISEAUTE      | ARO BISELADO      | 100,5X 91,9X 2,5H 2959 FE<br>1.UEBERNASSTUFE 100,50 MM RD<br>3,9567IN.                     |     |
| 954      | 116 2103 | 1          | OELSCHLITZRING | OIL CONTROL RING  | SEG RACL MLE A LUM | AN-RANUR-RASPACTE | SF 100,5X 91,4X 5 H 2984 CR<br>1.UEBERNASSTUFE 100,50 MM RD<br>3,9567 IN.                  |     |
| 955      | 223 1469 | 1          | KOLBEN         | PISTON/PLUNGER    | PISTON             | EMBOLO/PISTON     | 2.UEBERNASST. 101,00MM RD<br>3,9764 IN.  |     |
| 956      | 223 1470 | SZ         | KOLBENRING     | PISTON RING       | SEGMENT PISTON     | ARO EMBOLO/PISTON | 2.UEBERNASST. 101,00MM RD<br>3,9764 IN.  |     |

| Blk<br>Nr. | Teil-Nr. | Stück-<br>Zahl | Deutsch       | English           | Francés            | Español            | Nummer/Bemerkung   | ETK |
|------------|----------|----------------|---------------|-------------------|--------------------|--------------------|--|-----|
| 57         | 117 2312 | 1              | TRAPEZRING    | TRAPEZOIDAL RING  | SEGMENT TRAPEZ.    | ANIL-SECC-TRAPEC.  | D 101 X 92.4X3 H 2.52 K-CR<br>2-UEBERMASST. 101.00MM RD<br>3.9764 IN.  |     |
| 58         | 117 2311 | 2              | MINUTENRING   | TAPER PISTON RING | SEGM BISEAUTE      | ARO BISELADO       | 101 X 92.4X 2.5H 2.959-FE<br>2-UEBERMASST. 101.00MM RD<br>3.9764 IN.   |     |
| 59         | 117 2313 | 1              | ÖLSCHLITZRING | OIL CONTROL RING  | SEG RACL HLE A LUM | AN-RANUR-RASPAACTE | SF 101 X 91.9X 5 H 2.984 CR<br>2-UEBERMASST. 101.00MM RD<br>3.9764 IN. |     |



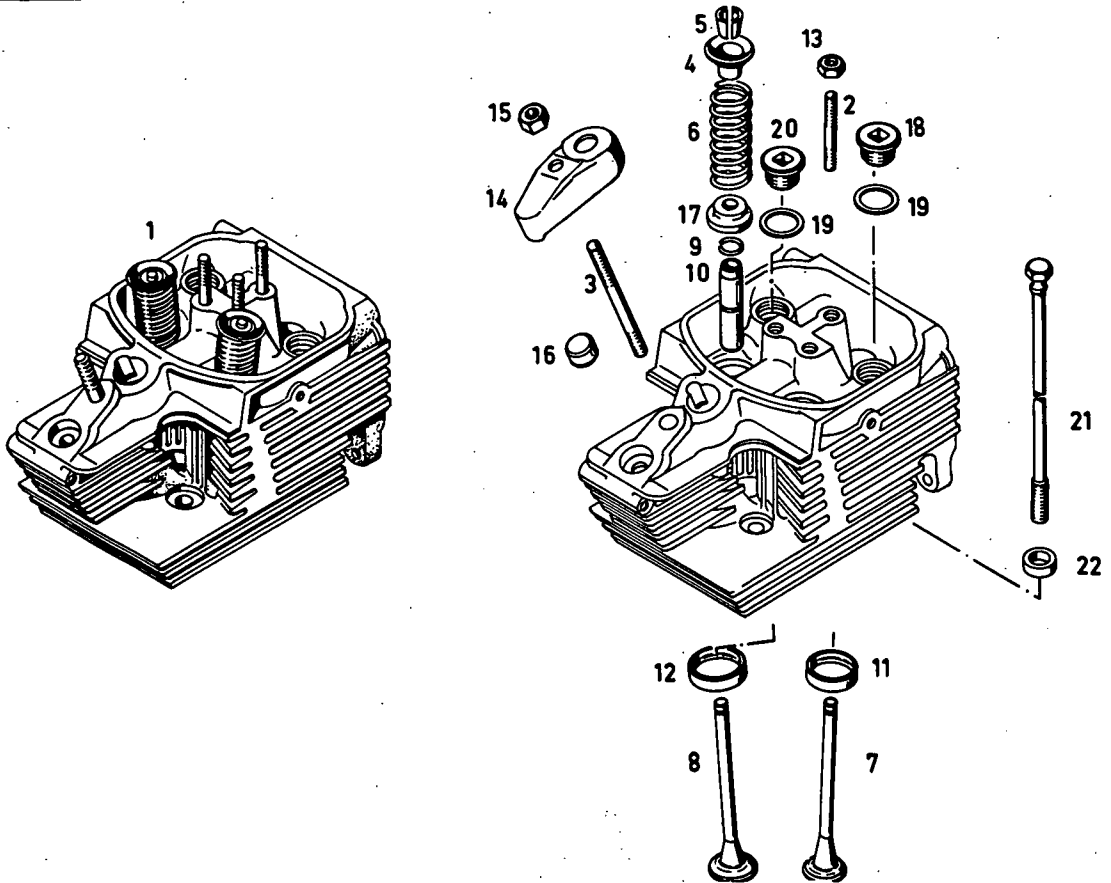

0150-08 500 6876

| Bild Nr. | Teile-Nr. | Stück-Zahl | Deutsch            | English            | Français           | Español            | Nummer/Bemerkung   | ETK |
|----------|-----------|------------|--------------------|--------------------|--------------------|--------------------|--|-----|
| 1        | 223 1354  | 1          | ZYLINDERKOPF       | CYLINDER HEAD      | CULASSE            | CULATA CILINDRO    | MONTAGETEIL  | 01  |
| 2        | 110 2046  | 3          | SCHRAUBE           | SCREW/BOLT         | VIS/BOULON         | TORNILLO           | M 8X 55 SM9 DIN 835-8.8  |     |
| 3        | 111 0254  | 1          | SCHRAUBE           | SCREW/BOLT         | VIS/BOULON         | TORNILLO           | M10X 65 SM9 DIN 835-6.8  |     |
| 4        | 337 1748  | 2          | FEDERTELLER        | SPRING CAP         | CUVETTE DE RESSORT | PLATO RESORTE      | 0155-08-45-23  | 01  |
| 5        | 116 8817  | 4          | VENTILKEGEL        | VALVE CONE         | CONE DE SOUPE      | CONO DE VALVULA    | ØH 70±0  | 01  |
| 6        | 336 9305  | 2          | DRUCKFEDER         | COMPRESSION SPRING | RESSORT DE COMPR   | RESORTE PRESION    | 0154-08-42-28  | 01  |
| 7        | 213 7300  | 1          | AUSLASSVENTIL      | EXHAUST VALVE      | SOUPE D ECHAPPM.   | VALV-ESCAPE        |  | 01  |
| 8        | 213 7301  | 1          | EINLASSVENTIL      | INLET VALVE        | SOUP D ADMISSION   | VALV-ADMIS.        |  | 01  |
| 9        | 121 5500  | 2          | SPRENGRING         | SNAP RING          | AGRAFE CIRCULAIRE  | ANILLO RETENCION   | 953 C 4  |     |
| 10       | 337 1761  | 2          | VENTILFUHRUNG      | VALVE GUIDE        | GUIDE DE SOUPE     | GUIA DE VALVULA    | 0155-08-50-04<br>NORMAL 15,00 MM RD 0-5706IN<br>UEBERNASST-POS-958-959 |     |
| 11       | 213 7306  | 1          | VENTILSITZRING     | SEAT INSERT RING   | BAGUE-SIEGE SOUP.  | ANILLO ASIENT-VALV | FUER AUSL.NORMAL 40,16MM RD<br>1,5811 IN. UEB.M.POS-952-954            |     |
| 12       | 213 7302  | 1          | VENTILSITZRING     | SEAT INSERT RING   | BAGUE-SIEGE SOUP.  | ANILLO ASIENT-VALV | F-EINLASS NORMAL 45,66MM RD<br>1,7976 IN. UEB.M.POS-955-957            |     |
| 13       | 111 2824  | 3          | SECHSKANTMUTTER    | HEX-NUT            | ECROU 6 PANS       | TUERCA HEXAGONAL   | M8 DIN 934-M8-A4C  |     |
| 14       | 213 7591  | 1          | BUEGEL             | YOKE/RETAINER      | ETRIER             | ESTRIBO            |  |     |
| 15       | 110 2659  | 1          | SECHSKANTMUTTER    | HEX-NUT            | ECROU 6 PANS       | TUERCA HEXAGONAL   | M 10 DIN 934-M8-A4C  |     |
| 16       | 213 7580  | 1          | SCHEIBE            | DISC/PANE/PLATE    | RONDELLE/DISQUE    | DISCO              |  |     |
| 17       | 213 7096  | 2          | FEDERTELLER        | SPRING CAP         | CUVETTE DE RESSORT | PLATO RESORTE      |  |     |
| 18       | 213 6596  | 1          | VERSCHLUSSSCHRAUBE | SCREW PLUG         | BOUCHON FILETE     | TAPON ROSCADO      | F-AUSLASS  |     |
| 19       | 111 8760  | 2          | DICHRING           | WASHER             | BAGUE D ETANCHEITE | ANILLO DE JUNTA    | A 26 X 31 DIN 7603-CU  |     |
| 20       | 213 6596  | 1          | VERSCHLUSSSCHRAUBE | SCREW PLUG         | BOUCHON FILETE     | TAPON ROSCADO      | F-EINLASS  |     |
| 21       | 210 1661  | 4          | SKT-DEHNSCHRAUBE   | WAISTED BOLT       | VIS EXTENS 6 PANS  | TORN-HEX-EXPANSION | 0155-08-51-17  | 01  |

| Bld Nr. | Teil-Nr. | Stück-Zahl | Deutsch          | English          | Français          | Español           | Nummer/Bemerkung  | ETK |
|---------|----------|------------|------------------|------------------|-------------------|-------------------|---|-----|
| 22      | 337 1666 | 4          | UNTERLEGSCHLEIBE | WASHER           | RONDELLE          | ARANDELA CALCE    | 0155-38-03-28   |     |
| 952     | 213 7307 | 1          | VENTILSITZRING   | SEAT INSERT RING | BAGUE-SIEGE SOUP. | ANILLO ASIEN-VALV | FUER AUSL-1-UEBERMASST.<br>40.25MM RD 1.5850 IN.        |     |
| 953     | 213 7308 | 1          | VENTILSITZRING   | SEAT INSERT RING | BAGUE-SIEGE SOUP. | ANILLO ASIEN-VALV | FUER AUSL-2-UEBERMASST.<br>40.35MM RD 1.5890 IN.        |     |
| 954     | 213 7309 | 1          | VENTILSITZRING   | SEAT INSERT RING | BAGUE-SIEGE SOUP. | ANILLO ASIEN-VALV | FUER AUSL-3-UEBERMASST.<br>40.45 MM RD 1.5929 IN.       |     |
| 955     | 213 7303 | 1          | VENTILSITZRING   | SEAT INSERT RING | BAGUE-SIEGE SOUP. | ANILLO ASIEN-VALV | FUER EINL-1-UEBERMASST.<br>45.75MM RD 1.8016 IN.        |     |
| 956     | 213 7304 | 1          | VENTILSITZRING   | SEAT INSERT RING | BAGUE-SIEGE SOUP. | ANILLO ASIEN-VALV | FUER EINL-2-UEBERMASST.<br>45.85MM RD 1.8055 IN.        |     |
| 957     | 213 7305 | 1          | VENTILSITZRING   | SEAT INSERT RING | BAGUE-SIEGE SOUP. | ANILLO ASIEN-VALV | FUER EINL-3-UEBERMASST.<br>45.95MM RD 1.8094 IN.        |     |
| 958     | 210 1679 | 2          | VENTILFUEHRUNG   | VALVE GUIDE      | GUIDE DE SOUPAPE  | GUIA DE VALVULA   | 0155-08-50-08<br>1-UEBERMASST.<br>15.25MM RD 0.6004 IN. |     |
| 959     | 210 1680 | 2          | VENTILFUEHRUNG   | VALVE GUIDE      | GUIDE DE SOUPAPE  | GUIA DE VALVULA   | 0155-08-50-09<br>2-UEBERMASST.<br>15.50MM RD 0.6102 IN. |     |



Zylinderkopfhaube  
 Rocker chamber cover  
 Culasse  
 Caperuza de culata

Stück/Zyl.-Einheit  
 Pieces/cyl. unit  
 Qté/cylindre  
 Cantid./unid. cilind.



0150-08-500 6586

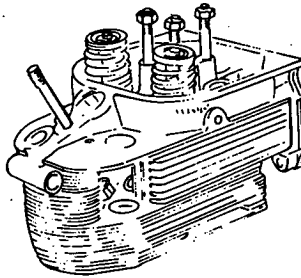
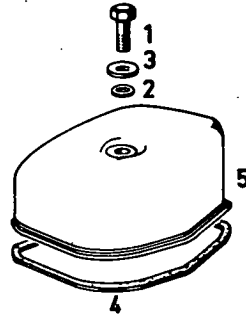

0150-08 500 6586

| Bild Nr. | Teile-Nr. | Stück-Zahl | Deutsch           | English         | Francés            | Español            | Nummer/Bemerkung         | ETK |
|----------|-----------|------------|-------------------|-----------------|--------------------|--------------------|--------------------------|-----|
| 1        | 111 1132  | 1          | SECHSKANTSCHRAUBE | HEX-BOLT        | VIS 6 PANS         | TORNILLO HEXAGONAL | M 8X 30 DIN 913- 8-8-A4C |     |
| 2        | 121 6307  | 1          | DICHRING          | WASHER          | BAGUE D ETANCHEITE | ANILLO DE JUNTA    | 2 914 A 8                | 01  |
| 3        | 110 7101  | 1          | SCHLEIBE          | DISC/PANE/PLATE | RONDELLE/DISQUE    | DISCO              | A 8-8 DIN 125-ST-A4C     |     |
| 4        | 337 1692  | 1          | DICHTUNG          | GASKET          | GARNITURE/JOINT    | JUNTA              | 0155-38-22-05            | 01  |
| 5        | 213 5910  | 1          | ZYLINDERKOPFHAUBE | COVER           | CHAPEAU DE CULASSE | CAPERUZA CULATA    |                          |     |

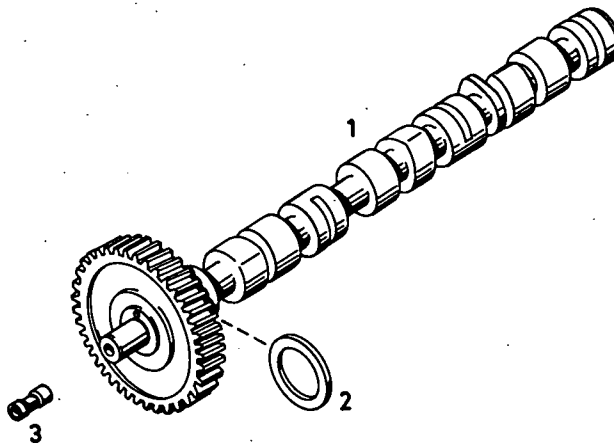

0150-10 500 6862

| Bild Nr. | Teil-Nr. | Stück-Zahl | Deutsch     | English         | Français        | Español        | Nummer/Bemerkung | ETK |
|----------|----------|------------|-------------|-----------------|-----------------|----------------|------------------|-----|
| 1        | 210 1222 | 1          | NOCKENWELLE | CAMSHAFT        | ARBRE A CAMES   | ARBOL DE LEVAS | 0150-10-02-140   |     |
| 2        | 336 7789 | 1          | SCHEIBE     | DISC/PANE/PLATE | RONDELLE/DISQUE | BISCO          | 0153-10-01-16    |     |
| 3        | 121 6884 | 1          | BUECHSE     | BUSH            | BOITE           | CASQUILLO      | 4 217 A          |     |



Steuerungsteile  
Timing gears  
Organes de distribution  
Partes de distribución

Stück/Zyl.-Einheit  
Pieces/cyl. unit  
Qté/cylindre  
Cantid./unid. cilind.

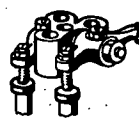

0150-11-500 5867

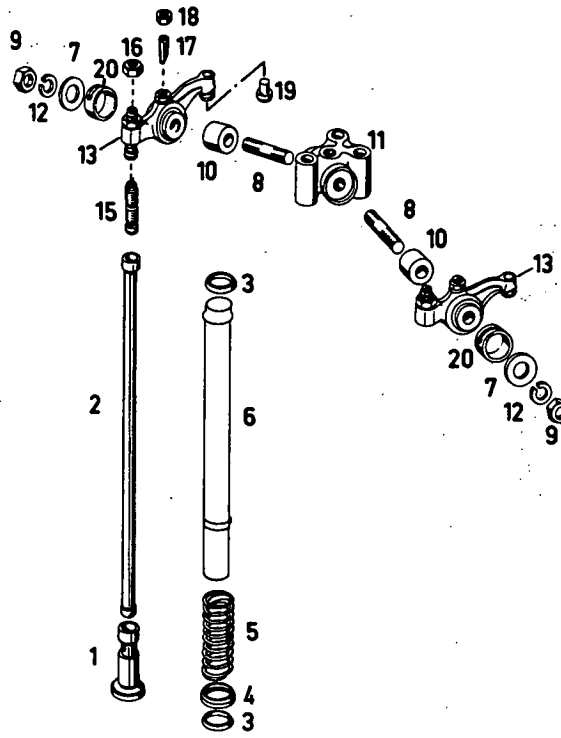

0150-11 500 5867

| Bld. Nr. | Teil-Nr. | Stück-Zahl | Deutsch          | English           | Français           | Español            | Nummer/Bemerkung  | ETK |
|----------|----------|------------|------------------|-------------------|--------------------|--------------------|---|-----|
| 1        | 337 1885 | 2          | VENTILSTOESSEL   | VALVE TAPPET      | POUSSOIR           | TAQUE DE VALVULA   | 0155-11-13-01   |     |
| 2        | 213 3785 | 2          | STOSSSTANGE      | PUSHROD           | BARRE PARE-CHOCS   | VARILLA EMPUJE     |   |     |
| 3        | 337 1881 | 4          | DICHTRING        | WASHER            | BAGUE D ETANCHEITE | ANILLO DE JUNTA    | 0155-11-10-31   | 01  |
| 4        | 337 1887 | 2          | KAPPE            | CAP               | CAPUCHON/CALOTTE   | SOMBREER-/CAPUCHON | 0155-11-13-05   |     |
| 5        | 337 1876 | 2          | SCHRAUBENFEDER   | HELICAL SPRING    | RESSORT A BOUDIN   | RESORTE HELICOIDAL | 0155-11-10-18   |     |
| 6        |          | IP         | SCHUTZROHR       | COVER TUBE        | TUBE PROTECTEUR    | TUBO PROTECTOR     | S-TAFEL 0150-11-502 2186<br>VERST.-AUSF. 0150-11-502 2185 |     |
| 7        | 121 6080 | 2          | SCHEIBE          | DISC/PANE/PLATE   | RONDELLE/DISQUE    | DISCO              | 2 306 A 6   |     |
| 8        | 111 3476 | 2          | STIFTSCHRAUBE    | STUD              | GOUJON             | ESPARRAGO          | M10 X 35 DIN 937-8-8-A4C                                  |     |
| 9        | 110 2659 | 2          | SECHSKANTMUTTER  | HEX-NUT           | ECROU 6 PANS       | TUERCA HEXAGONAL   | M10 DIN 934-M 8 A4C                                       |     |
| 10       | 337 1866 | 2          | BUCHSE           | BUSH              | DOUILLE            | CASQUILLO          | 0155-11-09-09   |     |
| 11       | 337 1867 | 1          | KIPPHEBELBOCK    | ROCKER BRACKET    | SUPP DE CULBUTEUR  | CABALLETE BALANCIN | 0155-11-09-11   |     |
| 12       | 110 2800 | 2          | FEDERING         | SPRING LOCKWASHER | RONDELLE GROUER    | ARANDELA ELASTICA  | A 10 DIN 128 A4C  |     |
| 13       | 223 0849 | 2          | KIPPHEBEL        | ROCKER ARM        | CULBUTEUR          | BALANCIN           | VOLLST.-F.-EIN-U.-AUSLASS<br>MIT BILD-NR. 15 U-16         |     |
| 15       | 336 5861 | 2          | EINSTELLSCHRAUBE | ADJUSTING SCREW   | VIS DE REGLAGE     | TORN-GRADUACION    | 0152-11-04-08   | 01  |
| 16       | 111 3146 | 2          | SECHSKANTMUTTER  | HEX-NUT           | ECROU 6 PANS       | TUERCA HEXAGONAL   | M10X1 DIN 936-M55   |     |
| 17       | 223 0850 | 2          | ÖL DUESE         | OIL NOZZLE        | GICLÉUR D HUILE    | TOBERA ACEITE      |   |     |
| 18       | 111 2813 | 2          | SECHSKANTMUTTER  | HEX-NUT           | ECROU 6 PANS       | TUERCA HEXAGONAL   | M 6 DIN 934-M 8 A4C                                       |     |
| 19       | 213 9600 | 2          | DRUCKPILZ        | THRUST PAD        | CHAMP DE POUSSEE   | SETA PRESION       |   | 01  |
| 20       | 223 0851 | 2          | BUCHSE           | BUSH              | DOUILLE            | CASQUILLO          |   |     |

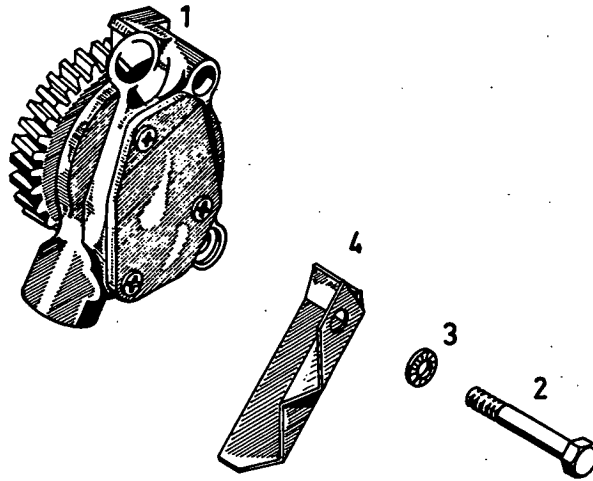

0150-14 500 4431

| Bild Nr. | Teil-Nr. | Stück-Zahl | Deutsch           | English        | Français           | Español                                      | Nummer / Bemerkung | ETK |
|----------|----------|------------|-------------------|----------------|--------------------|--|--------------------|-----|
| 1        | 213 0440 | 1          | SCHMIERÖLPUMPE    | LUBE OIL PUMP  | POMPE HUILE GRAISS | BOMBA ACEITE LUBR.                           |                    |     |
| 2        | 111 1168 | 2          | SECHSKANTSCHRAUBE | HEX-BOLT       | VIS 6 PANS         | TORNILLO HEXAGONAL. M 8X 60 DIN 931- 8.8-A4C |                    |     |
| 3        | 116 9689 | 2          | SICHERUNGSSCHEIBE | LOCKING WASHER | RONDELLE SECURITE  | ARANDELA SEGURIDAD. 8 H 2203                 |                    |     |
| 4        | 213 0375 | 1          | ABSCHIRMBLECH     | SHIELD         | TOLE-ECRAN         | CHAPA PROTECTORA                             |                    |     |

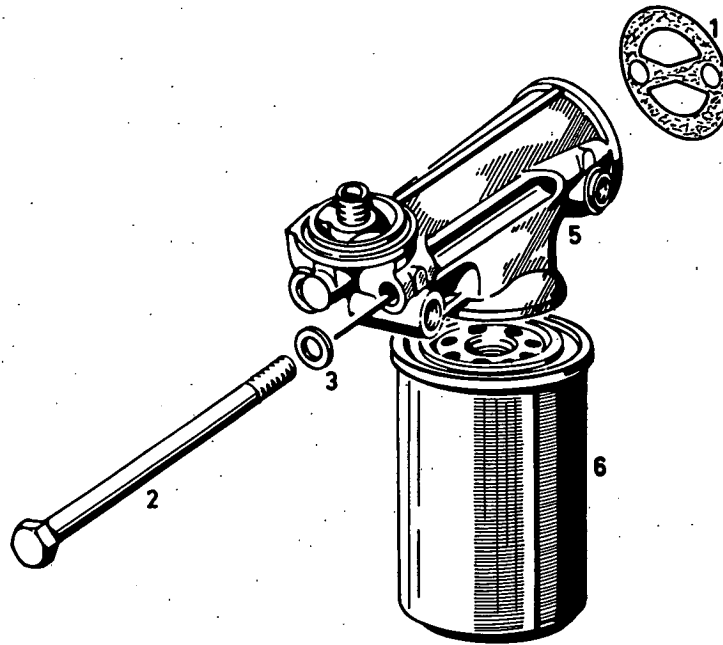

0150-15 500 4435

| Bild Nr. | Teile-Nr. | Stück-Zahl | Deutsch           | English         | Français           | Español            | Nummer/Bemerkung          | ETK |
|----------|-----------|------------|-------------------|-----------------|--------------------|--------------------|---------------------------|-----|
| 1        | 336 2983  | 1          | DICHTUNG          | GASKET          | GARNITURE/JOINT    | JUNTA              | 0150-15-43-01             | 01  |
| 2        | 111 1385  | 2          | SECHSKANTSCHRAUBE | HEX-BOLT        | VIS 6 PANS         | TORNILLO HEXAGONAL | M10X 160 DIN 931- 8-8-A4C |     |
| 3        | 110 7105  | 2          | SCHIBE            | DISC/PANE/PLATE | RONDELLE/DISQUE    | DISCO              | A10-6DIN 125-ST-A4C       |     |
| 5        | 213 5335  | 1          | FILTERTRAEGER     | SUPPORT         | SUPPORT DE FILTRE  | PORTA-FILTRO       |                           |     |
| 6        | 116 0024  | 1          | FILTERPATRONE     | CARTRIDGE       | CARTOUCHE FILTRANT | CARTUCHO FILTRO    | A 1 H 4123                | 01  |

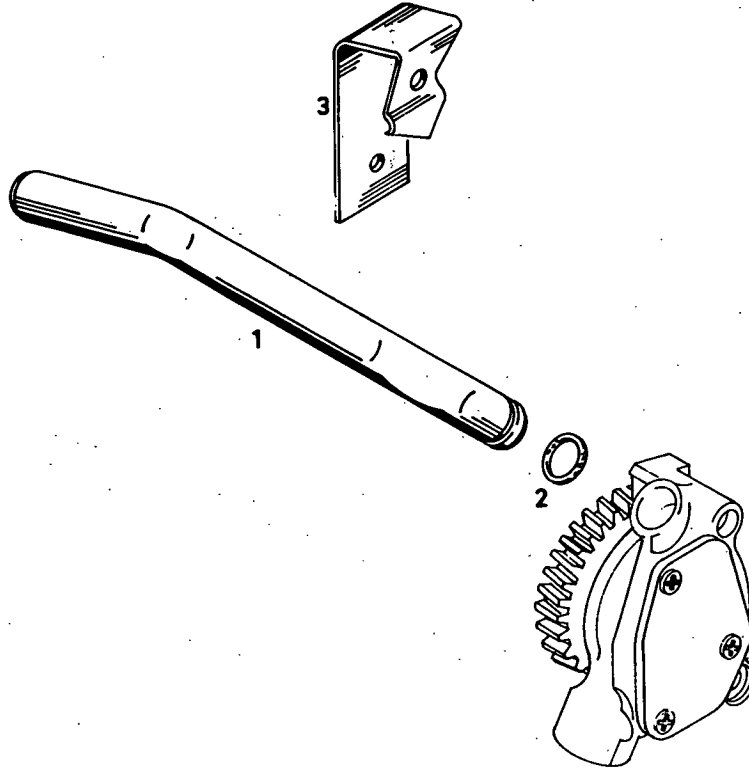

0150-16 500 3420

| Bild Nr. | Teile-Nr. | Stück-Zahl | Deutsch     | English     | Français       | Español            | Nummer/Bemerkung | ETK |
|----------|-----------|------------|-------------|-------------|----------------|--------------------|------------------|-----|
| 1.       | 213 6359  | 1          | ROHR        | PIPE/TUBE   | TUBE/TUYAU     | TUBO               |                  |     |
| 2.       | 116 6002  | 1          | RUNDGUMRING | O-SEAL      | ANNEAU TORIQUE | ANILLO GOMA REDOND | 14 X 3 H 721-S11 |     |
| 3.       | 346 9596  | 1          | BUEGELFEDER | YOKÉ SPRING | ETRIER-RESSORT | RESORTE ESTRIBO    | 0150-16-51-08    |     |





Schmierölsaugleitung  
Lube oil suction pipe  
Tuyau d'aspiration d'huile  
Tubería de aspiración de aceite lubricante

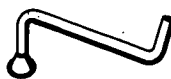

0150-16-500 6735

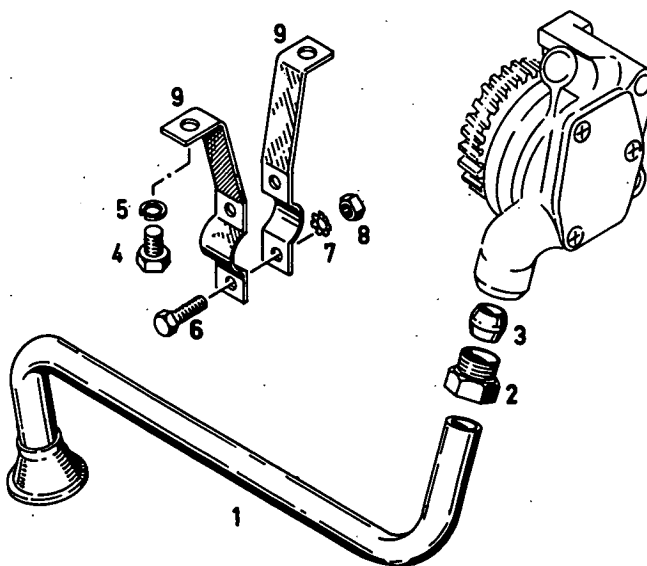

0150-16 500 6735

| Bild Nr. | Teile-Nr. | Stück-Zahl | Deutsch           | English           | Français          | Español            | Nummer/Bemerkung          | ETK |
|----------|-----------|------------|-------------------|-------------------|-------------------|--------------------|---------------------------|-----|
| 1        | 216 5716  | 1          | SAUGROHR          | SUCTION PIPE      | TUYAU ASPIRATION  | TUBO ASPIRACION    |                           |     |
| 2        | 121 6500  | 1          | UEBERWURFSCHRAUBE | CAP SCREW/NUT     | VIS CHAPEAU       | TORNILLO ENPALME   | 3 104 M 20                |     |
| 3        | 121 6512  | 1          | DOPPELKEILRING    | DUPLEX RING       | BAGUE CALAGE DBLE | ANILLO CUMA DOBLE  | 3 106 M 20                | 01  |
| 4        | 111 2299  | 2          | SECHSKANTSCHRAUBE | HEX-BOLT          | VIS 6 PANS        | TORNILLO HEXAGONAL | M 8 X 12 DIN 933- 8-8-A4C |     |
| 5        | 110 2799  | 2          | FEDERRING         | SPRING LOCKWASHER | RONDELLE GROUER   | ARANDELA ELASTICA  | A 8 DIN 128 A4C           |     |
| 6        | 111 2248  | 2          | SECHSKANTSCHRAUBE | HEX-BOLT          | VIS 6 PANS        | TORNILLO HEXAGONAL | M 6 X 15 DIN 933- 8-8     |     |
| 7        | 111 7861  | 2          | ZAHNSCHEIBE       | TOOTHED WASHER    | RONDELLE DENTEE   | ARANDELA DENTADA   | A 6,4 DIN 6797            |     |
| 8        | 111 2813  | 2          | SECHSKANTMUTTER   | HEX-NUT           | ECROU 6 PANS      | TUERCA HEXAGONAL   | M 6 DIN 934-M 8 A4C       |     |
| 9        | 336 3064  | 2          | ROHRSCHELLE       | PIPE CLIP         | COLLIER PR TUBES  | ABRAZADERA DE TUBO | 0150-16-53-15             |     |

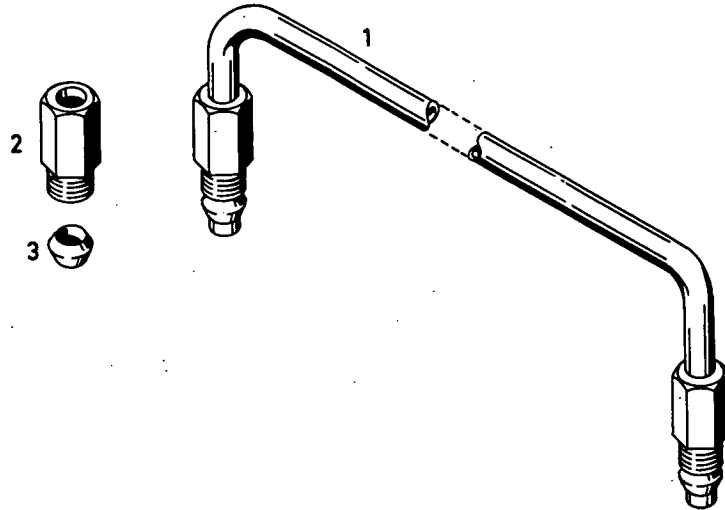
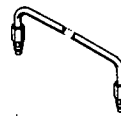

0150-16 500 6782

| Bild Nr. | Teile-Nr. | Stück-Zahl | Deutsch            | English       | Français           | Español            | Nummer/Bemerkung | ETK |
|----------|-----------|------------|--------------------|---------------|--------------------|--------------------|------------------|-----|
| 1        | 336 3070  | 1          | KURZSCHLUSSLEITUNG | BYPASS LINE   | BY-PASS            | LINEA CORTOCIRCUIT | 0150-16-60-10    |     |
| 2        | 336 3069  | 2          | UEBERWURFSCHRAUBE  | CAP SCREW/NUT | VIS CHAPEAU        | TORNILLO EMPALME   | 0150-16-60-02    |     |
| 3        | 123 6511  | 2          | DOPPELKEILRING     | DUPLEX RING   | BAGUE CALAGE DOBLE | ANILLO CUNA DOBLE  | 3 106 M 18       |     |

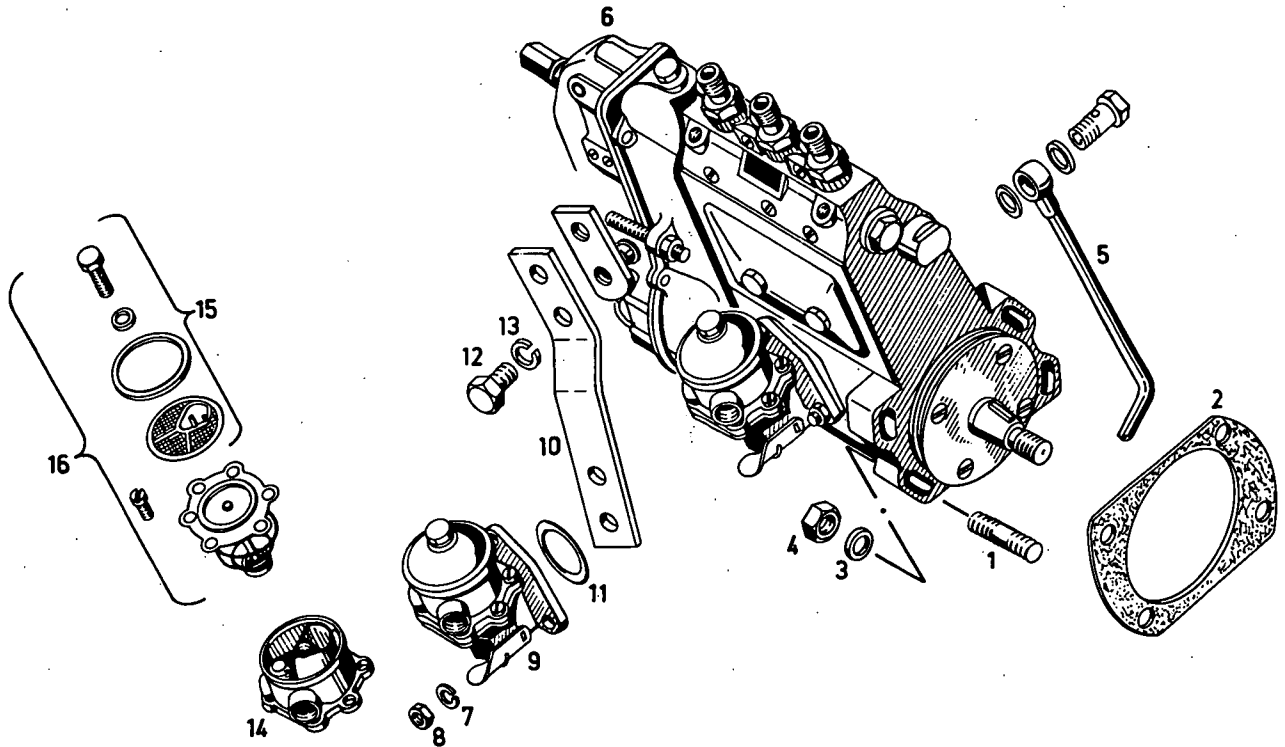
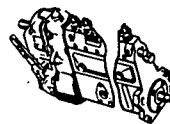

| Bld Nr. | Teil-Nr. | Stück-Zahl | Deutsch           | English           | Français          | Español            | 0150-17 500 1668<br>Nummer/Bemerkung       | ETK |
|---------|----------|------------|-------------------|-------------------|-------------------|--------------------|--|-----|
| 1       | 110 2301 | 4          | STIFTSCHRAUBE     | STUD              | GOUJON            | ESPARRAGO          | M10 X 30 DIN 934-6.8-A4C                   |     |
| 2       | 213 6717 | 1          | DICHTUNG          | GASKET            | GARNITURE/JOINT   | JUNTA              |  | 01  |
| 3       | 110 7105 | 4          | SCHEIBE           | DISC/PANE/PLATE   | RONDELLE/DISQUE   | DISCO              | A10.50IN 125-ST-A4C                        |     |
| 4       | 110 2659 | 4          | SECHSKANTMUTTER   | HEX-NUT           | ECROU 6 PANS      | TUERCA HEXAGONAL   | M10 DIN 934-M 8 A4C                        |     |
| 5       | 336 3161 | 1          | UEBERSTROMLEITUNG | OVERFLOW LINE     | CONDUITE DECHARGE | TUBERIA REBOSANTO  | 0150-17-12-10                              |     |
| 6       | 291 2697 | 1          | EINSPRITZPUMPE    | INJECTION PUMP    | POMPE D INJECTION | BOMBA INYECCION    | GRUNDAUSFUEHRUNG<br>2137706 K 0150-17 40PS |     |
| 7       | 110 2797 | 3          | FEDERRING         | SPRING LOCKWASHER | RONDELLE GROMER   | ARANDELA ELASTICA  | A 6 DIN 128 A4C                            |     |
| 8       | 111 2833 | 3          | SECHSKANTMUTTER   | HEX-NUT           | ECROU 6 PANS      | TUERCA HEXAGONAL   | M 6 DIN 934-M 8 A4C                        |     |
| 9       | 213 4531 | 1          | KRAFTSTOFFPUMPE   | FUEL PUMP         | POMPE A COMBUST   | BOMBA COMBUSTIBLE  |  |     |
| 10      | 213 9484 | 1          | HEBEL             | LEVER/ARM         | LEVIER            | PALANCA            |  |     |
| 11      | 116 2625 | 1          | RUNDGUMMRING      | O-SEAL            | ANNEAU TORIQUE    | ANILLO GOMA REDOND | 35 X 2.5 M 2927-S68                        |     |
| 12      | 111 2290 | 1          | SECHSKANTSCHRAUBE | HEX-BOLT          | VIS 6 PANS        | TORNILLO HEXAGONAL | M 6 X 12 DIN 933- 8.8-A4C                  |     |
| 13      | 110 2797 | 1          | FEDERRING         | SPRING LOCKWASHER | RONDELLE GROMER   | ARANDELA ELASTICA  | A 6 DIN 128 A4C                            |     |
| 14      | 210 2660 | 1          | PUMPENBERTEIL     | PUMP TOP          | PARTIE SUP POMPE  | PRTE.SUPR.BOMBA    | 0150-17-20-02                              |     |
| 15      | 126 0099 | 1          | REPARATURSATZ     | REPAIR KIT        | LOT DE REPARATION | LOTE REPARACIONES  |  | 01  |
| 16      | 213 0225 | 1          | REPARATURSATZ     | REPAIR KIT        | LOT DE REPARATION | LOTE REPARACIONES  |  | 01  |

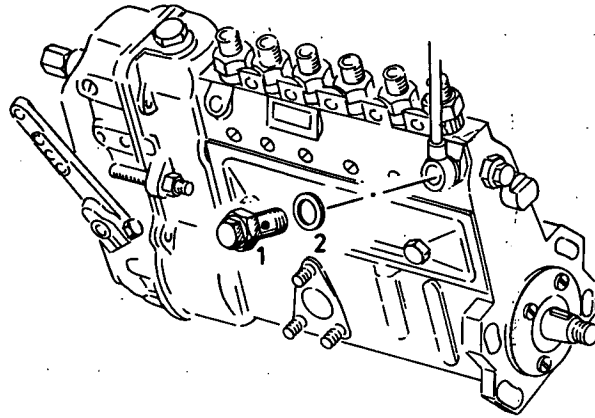
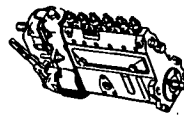

0150-17 500 3451

| Bild Nr. | Teil-Nr. | Stück-Zahl | Deutsch          | English        | Français           | Español           | Nummer/Bemerkung      | ETK |
|----------|----------|------------|------------------|----------------|--------------------|-------------------|-----------------------|-----|
| 1        | 213 5002 | 1          | UEBERSTROMVENTIL | OVERFLOW VALVE | SOUPE DE CHARGE    | VALV-REBOSAMIENTO |                       |     |
| 2        | 111 8673 | 2          | DICHTRING        | WASHER         | BAGUE D ETANCHEITE | ANILLO DE JUNTA   | A 14 X 20 DIN 7603-CU |     |

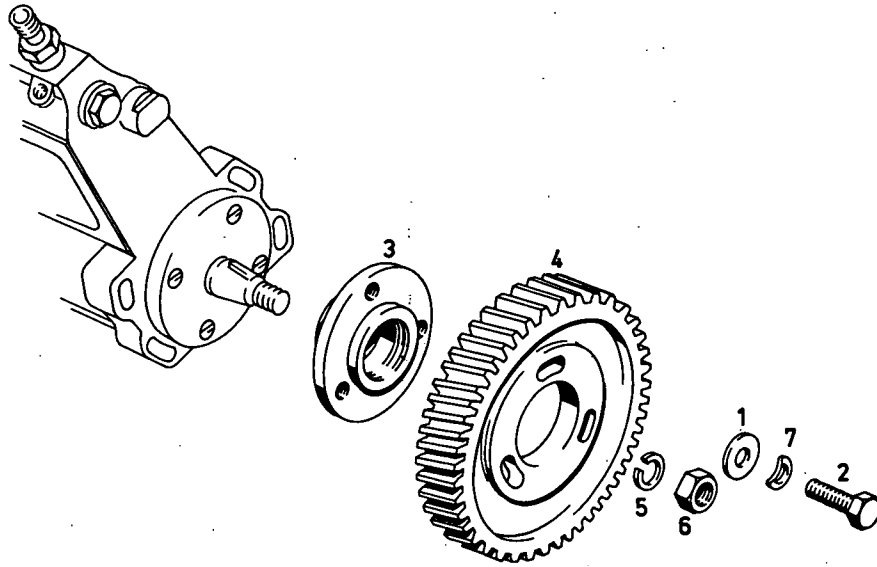

0150-18 500 5869

| Bild-Nr. | Teil-Nr. | Stück-Zahl | Deutsch           | English           | Français        | Español            | Nummer/Bemerkung            | ETK |
|----------|----------|------------|-------------------|-------------------|-----------------|--------------------|-----------------------------|-----|
| 1        | 123 1206 | 3          | SCHNEIBE          | DISC/PANE/PLATE   | RONDELLE/DISQUE | DISCO              | 2 308 A 51                  |     |
| 2        | 112 8196 | 3          | SECHSKANTSCHRAUBE | HEX-BOLT          | VIS 6 PANS      | TORNILLO HEXAGONAL | M 8X1 X 25 DIN 913- 8-8-A4C |     |
| 3        | 213 7284 | 1          | NABE              | HUB               | NOYEU           | CUBO               |                             |     |
| 4        | 213 7287 | 1          | ZAHNRAD           | GEAR              | ROUE DENTEE     | RUEDA DENTADA      |                             |     |
| 5        | 110 2801 | 1          | FEDERRING         | SPRING LOCKWASHER | RONDELLE GROMER | ARANDELA ELASTICA  | A 12 DIN 128 A4C            |     |
| 6        | 111 2861 | 1          | SECHSKANTMUTTER   | HEX-NUT           | ECROU 6 PANS    | TUERCA HEXAGONAL   | M12 DIN 934-M10             |     |
| 7        | 110 7281 | 3          | FEDERRING         | SPRING LOCKWASHER | RONDELLE GROMER | ARANDELA ELASTICA  | B 8 DIN 137                 |     |

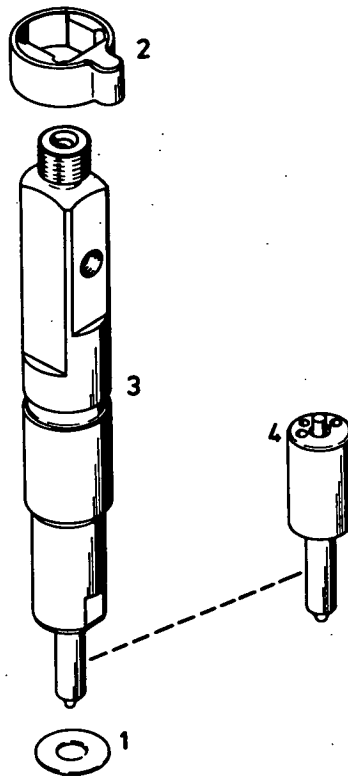

0150-19 500 3849

| Bild Nr. | Teil-Nr. | Stück-Zahl | Deutsch         | English  | Français           | Español         | Nummer/Bemerkung | ETK |
|----------|----------|------------|-----------------|----------|--------------------|-----------------|------------------|-----|
| 1        | 337 2364 | 1          | DICHRING        | WASHER   | BAGUE D'ETANCHEITE | ANILLO DE JUNTA | 0155-19-08-06    | 01  |
| 2        | 213 7568 | 1          | BUCHSE          | BUSH     | BOUILLE            | CASQUILLO       |                  |     |
| 3        | 213 7932 | 1          | EINSPRITZVENTIL | INJECTOR | SOUPAPE D'INJECT   | INJECTOR        |                  |     |
| 4        | 210 1221 | 1          | NESE            | NOZZLE   | INJECTEUR/GICLÉUR  | TOBERA          | 0155-19-10-03    | 01  |

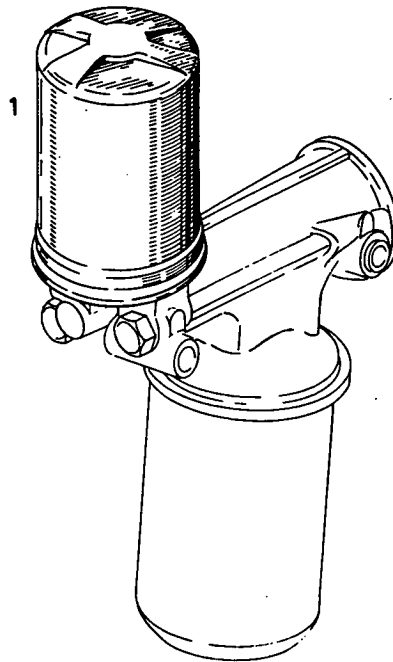

0150-20 500 3462

| Bild-Nr. | Teil-Nr. | Stück-Zahl | Deutsch          | English     | Francés          | Español            | Nummer/Bemerkung | ETK |
|----------|----------|------------|------------------|-------------|------------------|--------------------|------------------|-----|
| 1        | 116 0243 | 1          | KRAFTSTOFFFILTER | FUEL FILTER | FILTRE A COMBUST | FILTRO COMBUSTIBLE | 8.1 H 9337       | 03  |

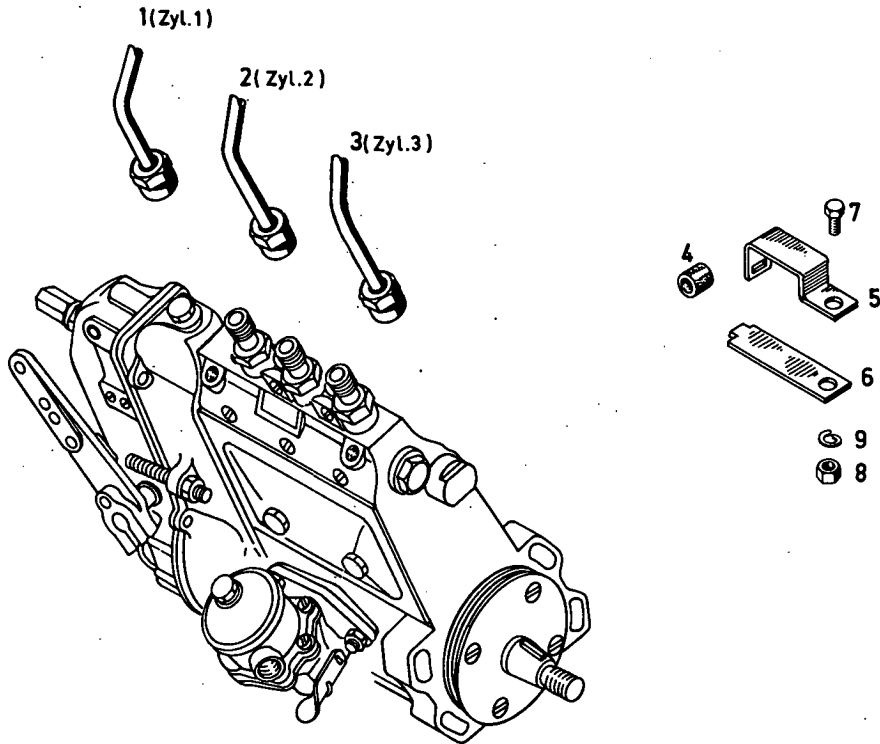
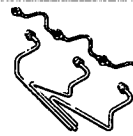

0150-21 500 6749

| Bild-Nr. | Teile-Nr. | Stück-Zahl | Deutsch           | English           | Français           | Español            | Nummer/Bemerkung         | ETK |
|----------|-----------|------------|-------------------|-------------------|--------------------|--------------------|--------------------------|-----|
| 1        | 213 7916  | 1          | EINSPRITZLEITUNG  | INJECTION LINE    | CONDUITE D INJECT  | TUBERIA INYECC-    | ZUM ZYL. 1               |     |
| 2        | 213 7917  | 1          | EINSPRITZLEITUNG  | INJECTION LINE    | CONDUITE D INJECT  | TUBERIA INYECC-    | ZUM ZYL. 2               |     |
| 3        | 213 7918  | 1          | EINSPRITZLEITUNG  | INJECTION LINE    | CONDUITE D INJECT  | TUBERIA INYECC-    | ZUM ZYL. 3               |     |
| 4        | 337 2269  | 2          | GUMMHUFFE         | RUBBER SLEEVE     | MANCHON CAOUTCHOUC | MANGUITO CAUCHO    | 0155-21-73-05            |     |
| 5        | 116 1469  | 1          | ROHRSCHELLE       | PIPE CLIP         | COLLIER PR TUBES   | ABRAZADERA DE TUBO | B 2X 6H 3220             |     |
| 6        | 117 0642  | 1          | SCHLUSSPLATTE     | END PLATE         | PLAQUE EXTREME     | PLACA FINAL        | C 2X 6H 3220             |     |
| 7        | 111 2240  | 1          | SECHSKANTSCHRAUBE | HEX-BOLT          | VIS 6 PANS         | TORNILLO HEXAGONAL | M 6X 12 DIN 933- 8-8-A4C |     |
| 8        | 111 2813  | 1          | SECHSKANTRUTTER   | HEX-NUT           | ECROU 6 PANS       | TUERCA HEXAGONAL   | M 6 DIN 934-M 8 A4C      |     |
| 9        | 110 2797  | 1          | FEDERRING         | SPRING LOCKWASHER | RONDELLE GROMER    | ARANDELA ELASTICA  | A 6 DIN 128 A4C          |     |



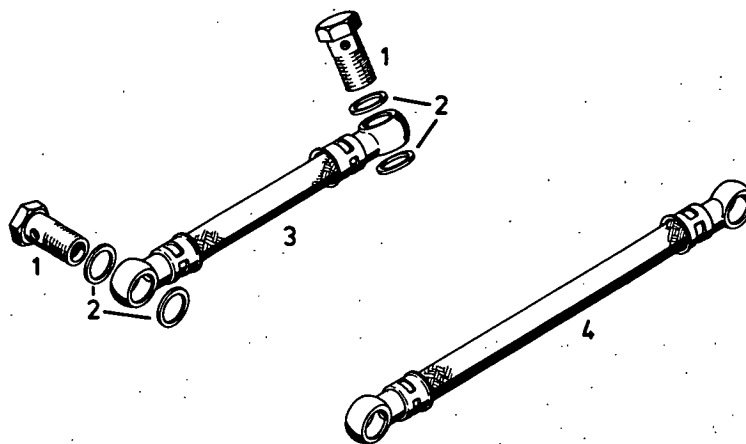

0150-21-500 6858

| Bild<br>nr. | Teile-Nr. | Stück-<br>Zahl | Deutsch         | English    | Français           | Español         | Nummer/Bemerkung      | ETK |
|-------------|-----------|----------------|-----------------|------------|--------------------|-----------------|-----------------------|-----|
| 1           | 111 9246  | 4              | HOHLSCHRAUBE    | BANJO-BOLT | VIS BANJO          | TORNILLO RACOR  | A 8 DIN 7623 VZKC     |     |
| 2           | 111 8673  | 8              | DICHRING        | WASHER     | BAGUE D ETANCHEITE | ANILLO DE JUNTA | A 14 X 20 DIN 7603-CU |     |
| 3           | 124 3384  | 1              | SCHLAUCHLEITUNG | HOSE       | CONDUITE FLEXIBLE  | MANGUERA        |                       | 03  |
| 4           | 126 6159  | 1              | SCHLAUCHLEITUNG | HOSE       | CONDUITE FLEXIBLE  | MANGUERA        | 8734-80-03-150        | 03  |

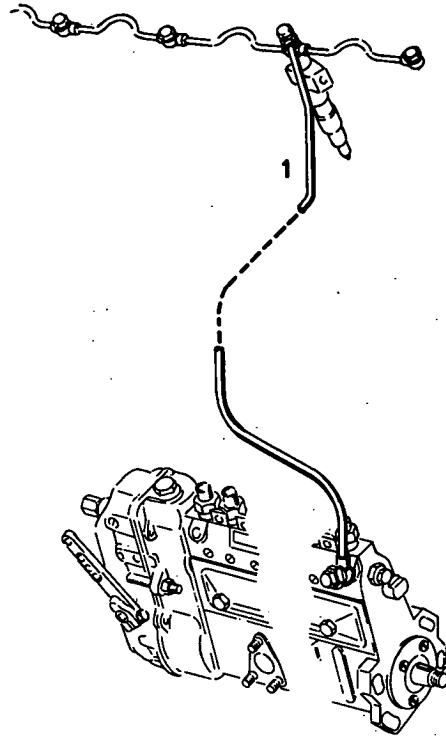
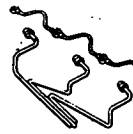

0150-21 500 4680

| Bild Nr. | Teil-Nr. | Stück-Zahl | Deutsch           | English       | Français          | Español            | Nummer/Bemerkung | ETK |
|----------|----------|------------|-------------------|---------------|-------------------|--------------------|------------------|-----|
| 1        | 213 7519 | 1          | UEBERSTROMLEITUNG | OVERFLOW LINE | CONDUITE DECHARGE | TUBERIA REBOSANTO. |                  |     |

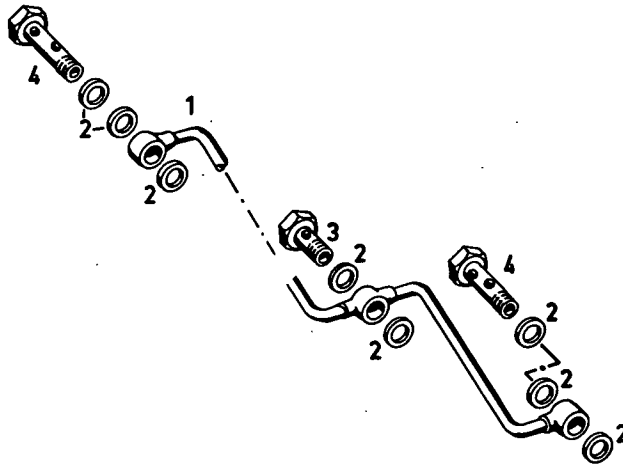
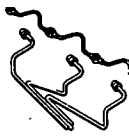

0150-21 500 6861

| Bild Nr. | Teil-Nr. | Stück-Zahl | Deutsch       | English          | Français           | Español             | Nummer/Bemerkung       | ETK |
|----------|----------|------------|---------------|------------------|--------------------|---------------------|------------------------|-----|
| 1        | 213 7996 | 1          | LECKÖLLEITUNG | BACKLEAKAGE LINE | COND HUILE DE FUIT | TUBER.COMBUST.SOBR. |                        |     |
| 2        | 111 8647 | 8          | DICHTRING     | WASHER           | BAGUE D ETANCHEITE | ANILLO DE JUNTA     | A 8 X 11,5 DIN 7603-CU | 01  |
| 3        | 111 9233 | 1          | HÖHLSCHRAUBE  | BANJO BOLT       | VIS BANJO          | TORNILLO RACOR      | A 2-DIN 7623 VZKC      |     |
| 4        | 121 6492 | 2          | HÖHLSCHRAUBE  | BANJO BOLT       | VIS BANJO          | TORNILLO RACOR      | 3 103 F 5              |     |

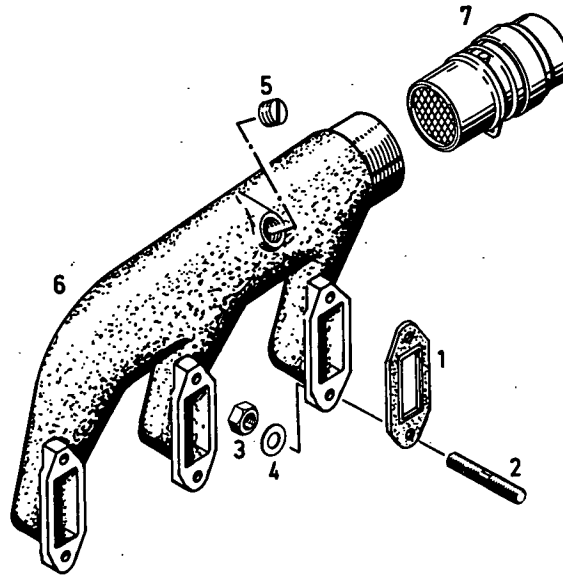

0150-22 500 6836

| Bild Nr. | Teil-Nr. | Stück-Zahl | Deutsch         | English            | Français           | Español           | Nummer/Bemerkung         | ETK |
|----------|----------|------------|-----------------|--------------------|--------------------|-------------------|--------------------------|-----|
| 1        | 337 1689 | 3          | DICHTUNG        | GASKET             | GARNITURE/JOINT    | JUNTA             | 0155-38-20-99            | 01  |
| 2        | 111 0190 | 6          | STIFTSCHRAUBE   | STUD               | GOUJON             | ESPARRAGO         | M 8x 35 SN4 DIN 835- 8-8 |     |
| 3        | 111 2024 | 6          | SECHSKANTMUTTER | HEX-NUT            | ECROU 6 PANS       | TUERCA HEXAGONAL  | M 8 DIN 934-M 8 A4C      |     |
| 4        | 110 7101 | 6          | SCHEIBE         | DISC/PANE/PLATE    | RONDELLE/DISQUE    | DISCO             | A 8.4 DIN 125-ST-A4C     |     |
| 5        | 116 5789 | 1          | SCHLITZSTOPFEN  | SLOTTED PLUG       | BOUCHON FENDU      | TAPON RANURADO    | M20x1.5 H 710            |     |
| 6        | 213 5532 | 1          | LUFTANSAUGROHR  | INTAKE PIPE/MANIF. | TUBE D ASPIR D AIR | TUBO ASPIRAC-AIRE |                          |     |
| 7        | 116 1412 | 1          | HEIZROHR        | HEATING TUBE       | TUBE CHAUFFANT     | TUBO CALEFACCION  | M 10x5 H 7628            |     |

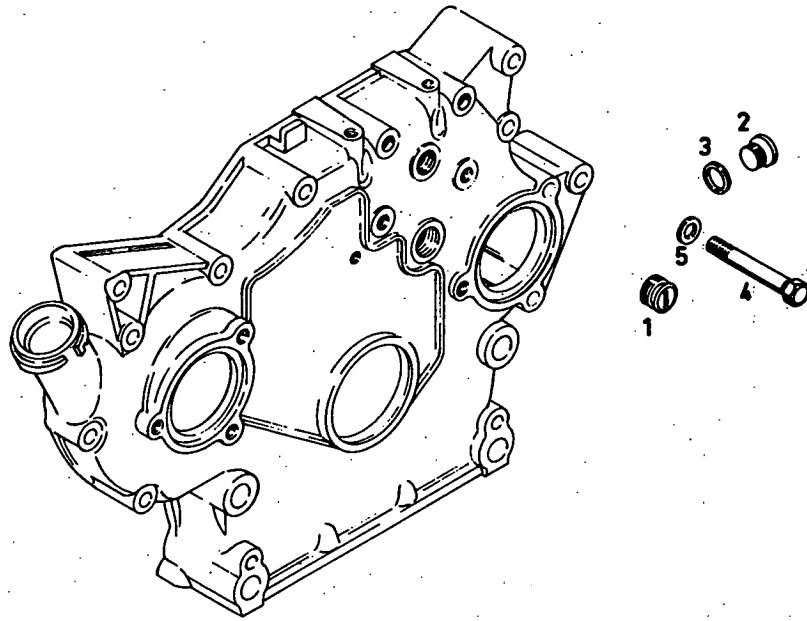

0150-33 500 3549

| Bild Nr. | Teil-Nr. | Stück-Zahl | Deutsch            | English         | Français           | Español            | Nummer/Bemerkung         | ETK |
|----------|----------|------------|--------------------|-----------------|--------------------|--------------------|--------------------------|-----|
| 1.       | 116 5788 | 1          | SCHLITZSTOPFEN     | SLOTTED PLUG    | BOUCHON FENDU      | TAPON RANURADO     | M18X1,5 H 710            |     |
| 2.       | 111 0422 | 1          | VERSCHLUSSSCHRAUBE | SCREW PLUG      | BOUCHON FILETE     | TAPON ROSCADO      | M12X1,5 DIN 908          |     |
| 3.       | 111 8673 | 1          | DICHTRING          | WASHER          | BAGUE D'ÉTANCHEITE | ANILLO DE JUNTA    | A 12 X 15,5 DIN 7603-CU  |     |
| 4.       | 111 1179 | 2          | SEENSKANTSCHRAUBE  | HEX BOLT        | VIS 6/PANS         | TORNILLO HEXAGONAL | M 8 X 70 DIN 933-8.8-ANC |     |
| 5.       | 110 7101 | 2          | SCHWEIBE           | DISC/PANE/PLATE | RONDELLE/DISQUE    | DISCO              | A 8,4 DIN 125-ST-ANC     |     |

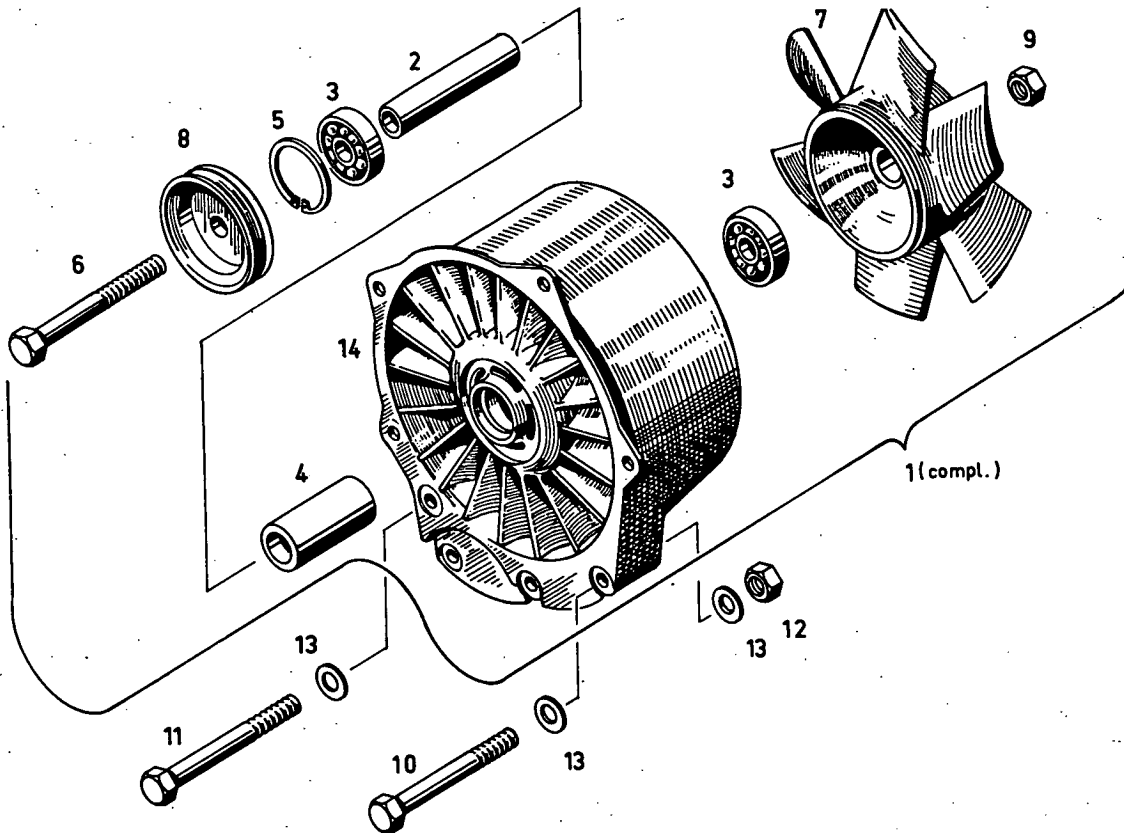

0150-39 500 4526

| Bild Nr. | Teil-Nr. | Stück-Zahl | Deutsch            | English         | Français            | Español            | Nummer/Bemerkung           | ETK |
|----------|----------|------------|--------------------|-----------------|---------------------|--------------------|----------------------------|-----|
| 1        | 223 1363 | 1          | KÜHLGEBLÄSE        | COOLING BLOWER  | SOUFLANTE REFRROID  | VENTILADOR REFRIG  |                            |     |
| 2        | 336 3658 | 1          | HÖHLWELLE          | QUILL SHAFT     | ARBRE CREUX         | EJE HUECO          | 0150-39-05-03              |     |
| 3        | 110 7041 | 2          | KILLENKUGELLAGER   | BALL BEARING    | ROUL. RAINURE BILLE | COJ. BOLAS F340    | 6204 Z C3DIN 625           | 01  |
| 4        | 213 3633 | 1          | BUCHSE             | BUSH            | BOUILLE             | CASQUILLO          |                            |     |
| 5        | 110 7834 | 1          | SICHERUNGSRING     | CIRCLIP         | CIRCLIP             | CIRCLIP            | 47X1,75DIN 472             | 01  |
| 6        | 111 1584 | 1          | SECHSKANTSCHRAUBE  | HEX.BOLT        | VIS 6-PANS          | TORNILLO HEXAGONAL | M12X 140 DIN 931-M 8-8-A9C | 01  |
| 7        | 213 6402 | 1          | LAUFRAD            | BOTTOM ROLLER   | ROUE A-AUBES/ROTOR  | ROTOR/RODILL-RODAD |                            |     |
| 8        | 213 3636 | 1          | KEILRIEMENSCHLEIBE | V-BELT PULLE    | POULIE-COURR TRAP   | POLEA ACANALADA    |                            |     |
| 9        | 111 2858 | 1          | SECHSKANTMUTTER    | HEX.NUT         | ECROU 6 PANS        | TUERCA HEXAGONAL   | M12 DIN 934-M 8 A9C        |     |
| 10       | 111 1210 | 3          | SECHSKANTSCHRAUBE  | HEX.BOLT        | VIS 6 PANS          | TORNILLO HEXAGONAL | M 8X 105 DIN 931- 8-8-A9C  |     |
| 11       | 112 6474 | 1          | SECHSKANTSCHRAUBE  | HEX.BOLT        | VIS 6 PANS          | TORNILLO HEXAGONAL | M 8X 95 DIN 931- 8-8-A9C   |     |
| 12       | 111 2824 | 1          | SECHSKANTMUTTER    | HEX.NUT         | ECROU 6 PANS        | TUERCA HEXAGONAL   | M 8 DIN 934-M 8 A9C        |     |
| 13       | 110 7101 | 5          | SCHEIBE            | DISC/PANE/PLATE | RONDELLE/DISQUE     | DISCO              | A 8,4DIN 125-ST-A9C        |     |
| 14       | 223 1362 | 1          | GEBLÄSEHAUPT       | BLOWER JACKET   | ENVELOPPE SOUFFLTE  | ENVOLV-SOPLANTE    |                            |     |

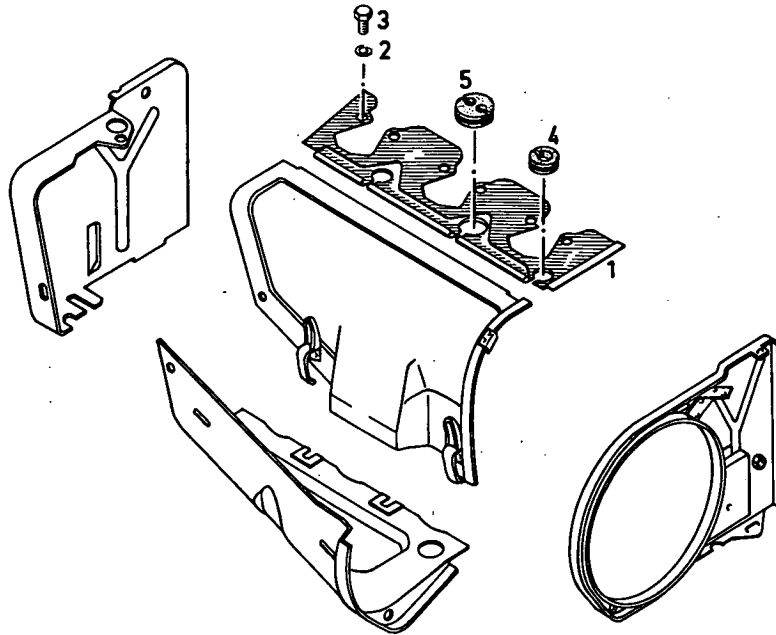

0150-40 500 6773

| Bild Nr. | Teil-Nr. | Stück-Zahl | Deutsch           | English           | Français         | Español            | Nummer/Bemerkung          | ETK |
|----------|----------|------------|-------------------|-------------------|------------------|--------------------|---------------------------|-----|
| 1        | 213 7356 | 1          | FUEHRUNGSLEISTE   | GUIDE RAIL        | BARRE CONDUCTR   | LISTON GUIA        |                           |     |
| 2        | 110 2797 | 6          | FEDERRING         | SPRING LOCKWASHER | RONDILLE GROVER  | ARANDELA ELASTICA  | A 6 DIN 128 A4C           |     |
| 3        | 111 2251 | 6          | SECHSKANTSCHRAUBE | HEX.BOLT          | VIS 6 PANS       | TORNILLO HEXAGONAL | M 6 X 15 DIN 933- 8.8-A4C |     |
| 4        | 116 0592 | 2          | GUMMITUELLE       | RUBBER GROMMET    | GAINE CAOUTCHOUC | FUNDA CAUCHO       | F 6.5X21 X 1.5 H 2928     |     |
| 5        | 336 1809 | 1          | GUMMITUELLE       | RUBBER GROMMET    | GAINE CAOUTCHOUC | FUNDA CAUCHO       | 0146-21-03-05             |     |

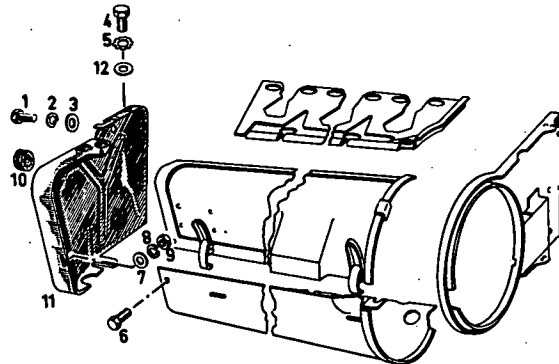

0150-40 500 3578

| Bild Nr. | Teile-Nr. | Stück-Zahl | Deutsch           | English           | Français           | Español            | Nummer/Bemerkung          | ETK |
|----------|-----------|------------|-------------------|-------------------|--------------------|--------------------|---------------------------|-----|
| 1        | 111 2240  | 1          | SECHSKANTSCHRAUBE | HEX-BOLT          | VIS 6 PANS         | TORNILLO HEXAGONAL | M 6 X 12 DIN 933- 8-8-A9C |     |
| 2        | 110 2797  | 1          | FEDERRING         | SPRING LOCKWASHER | RONDELLE GROUËR    | ARANDELA ELASTICA  | A 6 DIN 128 A9C           |     |
| 3        | 121 5850  | 1          | SCHEIBE           | DISC/PANE/PLATE   | RONDELLE/DISQUE    | DISCO              | 1 144 D                   |     |
| 4        | 111-2299  | 1          | SECHSKANTSCHRAUBE | HEX-BOLT          | VIS 6 PANS         | TORNILLO HEXAGONAL | M 8 X 12 DIN 933- 8-8-A9C |     |
| 5        | 110-7283  | 1          | FEDERSCHEIBE      | SPRING WASHER     | RONDELLE ELASTIQUE | ARANDELA ELASTICA  | B 8 DIN 137 VZKC          |     |
| 6        | 111 2240  | 1          | SECHSKANTSCHRAUBE | HEX-BOLT          | VIS 6 PANS         | TORNILLO HEXAGONAL | M 6 X 12 DIN 933- 8-8-A9C |     |
| 7        | 110 7095  | 1          | SCHEIBE           | DISC/PANE/PLATE   | RONDELLE/DISQUE    | DISCO              | A 6,4 DIN 125-ST-A9C      |     |
| 8        | 110 2797  | 1          | FEDERRING         | SPRING LOCKWASHER | RONDELLE GROUËR    | ARANDELA ELASTICA  | A 6 DIN 128 A9C           |     |
| 9        | 111 2813  | 1          | SECHSKANMUTTER    | HEX-NUT           | ECROU 6 PANS       | TUERCA HEXAGONAL   | M 6 DIN 934-M 8 A9C       |     |
| 10       | 116 7425  | 1          | GUMMITUELLE       | RUBBER GROMMET    | GAINE CAOUTCHOUC   | FUNDA CAUCHO       | D13,5X17 X 1,5 M 2928     |     |
| 11       | 210 1805  | 1          | BLECH             | PLATE             | TOLE               | CHAPA              | 0150-40-103-17            |     |
| 12       | 110 7101  | 1          | SCHEIBE           | DISC/PANE/PLATE   | RONDELLE/DISQUE    | DISCO              | A 8,4 DIN 125-ST-A9C      |     |



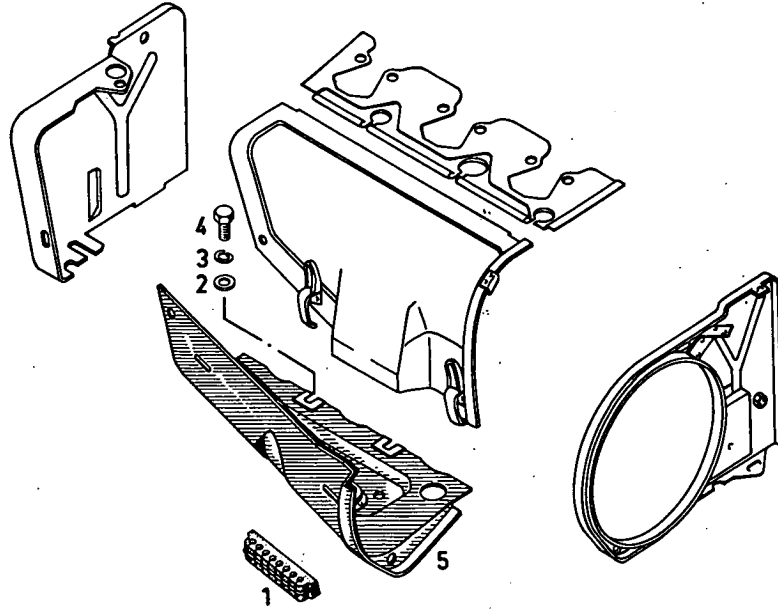
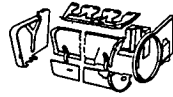

0150-40 500 6777

| Bild-Nr. | Teile-Nr. | Stück-Zahl | Deutsch           | English           | Francés          | Español            | Nummer/Bemerkung          | ETK |
|----------|-----------|------------|-------------------|-------------------|------------------|--------------------|---------------------------|-----|
| 1        | 210 1802  | 1          | GUMMI             | RUBBER            | CAOUTCHOUC       | GOMA/CAUCHO        | 0150-40-103-51            |     |
| 2        | 110 7101  | 3          | SCHEIBE           | DISC/PANE/PLATE   | RONDELLE/DISQUE  | DISCO              | A 8.4 DIN 125-ST-ANC      |     |
| 3        | 110 2799  | 3          | FEDERRING         | SPRING LOCKWASHER | RONDELLE GROUVER | ARANDELA ELASTICA  | A 8 DIN 128 ANC           |     |
| 4        | 111 2299  | 3          | SECHSKANTSCHRAUBE | HEX-BOLT          | VIS 6 PANS       | TORNILLO HEXAGONAL | M 8 X 12 DIN 933- 8-8-ANC |     |
| 5        | 210 1700  | 1          | LUFTFUHRUNGSTEIL  | DUCT PART         | PARTIE GUIDE-AIR | PZA-GUIA AIRE      |                           |     |



Luftführungs-Oberteil  
 Air guide upper part  
 Part sup cart vent  
 Parte sup. guia de adre

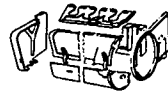

0150-40-500 6780

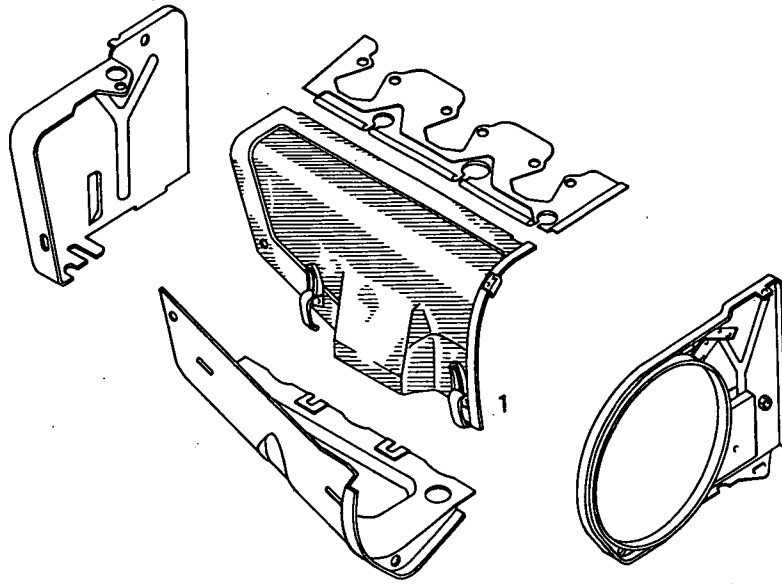

0150-40 500 6780

| Bild Nr. | Teile-Nr. | Stück-Zahl | Deutsch          | English   | Français         | Español       | Nummer/Bemerkung | ETK |
|----------|-----------|------------|------------------|-----------|------------------|---------------|------------------|-----|
| 1        | 210 1702  | 1          | LUFTFUHRUNGSTEIL | DUCT PART | PARTIE GUIDE-AIR | PZA.GUIA AIRE | 0150-40-120-10   |     |

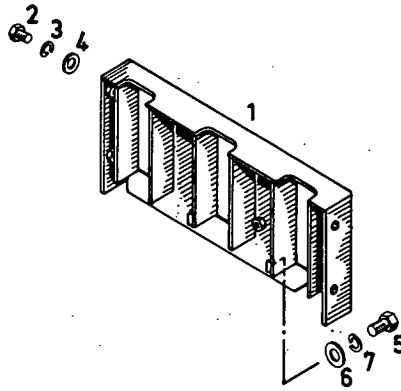
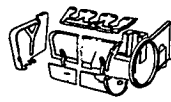

0150-40 500 6839

| Bild Nr. | Teile-Nr. | Stück-Zahl | Deutsch           | English           | Français        | Español            | Nummer/Bemerkung         | ETK |
|----------|-----------|------------|-------------------|-------------------|-----------------|--------------------|--------------------------|-----|
| 1        | 210 2217  | 1          | ABSCHIRMBLECH     | SHIELD            | TOLE-ECRAN      | CHAPA PROTECTORA   | 0150-40-121-10           |     |
| 2        | 111 2232  | 4          | SECHSKANTSCHRAUBE | HEX-BOLT          | VIS 6 PANS      | TORNILLO HEXAGONAL | M 6X 10 DIN 933- 8-8-A4C |     |
| 3        | 110 2797  | 4          | FEDERRING         | SPRING LOCKWASHER | RONDELLE GROMER | ARANDELA ELASTICA  | A 6 DIN 128 A4C          |     |
| 4        | 121 5850  | 4          | SCHEIBE           | DISC/PANE/PLATE   | RONDELLE/DISQUE | DISCO              | 1 144 D                  |     |
| 5        | 111 2305  | 2          | SECHSKANTSCHRAUBE | HEX-BOLT          | VIS 6 PANS      | TORNILLO HEXAGONAL | M 8X 15 DIN 933- 8-8-A4C |     |
| 6        | 110 7101  | 2          | SCHEIBE           | DISC/PANE/PLATE   | RONDELLE/DISQUE | DISCO              | A 8-4DIN 125-ST-A4C      |     |
| 7        | 110 2799  | 2          | FEDERRING         | SPRING LOCKWASHER | RONDELLE GROMER | ARANDELA ELASTICA  | A 8 DIN 128 A4C          |     |

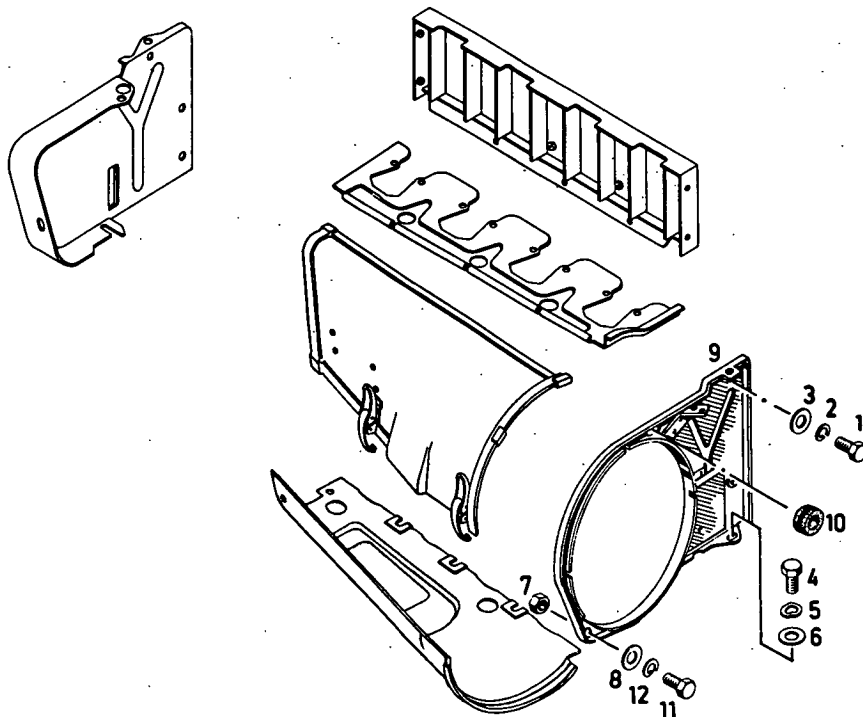

0150-40 500 4653

| Bild Nr. | Teile-Nr. | Stück-Zahl | Deutsch           | English           | Français           | Español            | Nummer/Bemerkung         | ETK |
|----------|-----------|------------|-------------------|-------------------|--------------------|--------------------|--------------------------|-----|
| 1        | 111 2240  | 1          | SECHSKANTSCHRAUBE | HEX-BOLT          | VIS 6 PANS         | TORNILLO HEXAGONAL | M 6X 12 DIN 933- 8-8-A4C |     |
| 2        | 110 2797  | 1          | FEDERRING         | SPRING LOCKWASHER | RONDELLE GROMER    | ARANDELA ELASTICA  | A 6 DIN 128 A4C          |     |
| 3        | 121 5650  | 1          | SCHEIBE           | DISC/PANE/PLATE   | RONDELLE/DISQUE    | DISCO              | 1 144 D                  |     |
| 4        | 111 2299  | 1          | SECHSKANTSCHRAUBE | HEX-BOLT          | VIS 6 PANS         | TORNILLO HEXAGONAL | M 8X 12 DIN 933- 8-8-A4C |     |
| 5        | 110 7283  | 1          | FEDERSCHEIBE      | SPRING WASHER     | RONDELLE ELASTIQUE | ARANDELA ELASTICA  | B 8 DIN 137 VZKC         |     |
| 6        | 110 7101  | 1          | SCHEIBE           | DISC/PANE/PLATE   | RONDELLE/DISQUE    | DISCO              | A 8-4DIN 125-ST-A4C      |     |
| 7        | 111 2813  | 1          | SECHSKANTMUTTER   | HEX-NUT           | ECROU 6 PANS       | TUERCA HEXAGONAL   | M 6 DIN 934-M 8 A4C      |     |
| 8        | 110 7095  | 1          | SCHEIBE           | DISC/PANE/PLATE   | RONDELLE/DISQUE    | DISCO              | A 6-4DIN 125-ST-A4C      |     |
| 9        | 210 1498  | 1          | BLECH             | PLATE             | TOLE               | CHAPA              |                          |     |
| 10       | 116 7425  | 1          | GUMMITUELLE       | RUBBER GROMMET    | GAINE CAOUTCHOUC   | FUNDA CAUCHO       | D13-5X17 X 1.5 H 2928    |     |
| 11       | 111 2240  | 1          | SECHSKANTSCHRAUBE | HEX-BOLT          | VIS 6 PANS         | TORNILLO HEXAGONAL | M 6X 12 DIN 933- 8-8-A4C |     |
| 12       | 110 2797  | 1          | FEDERRING         | SPRING LOCKWASHER | RONDELLE GROMER    | ARANDELA ELASTICA  | A 6 DIN 128 A4C          |     |

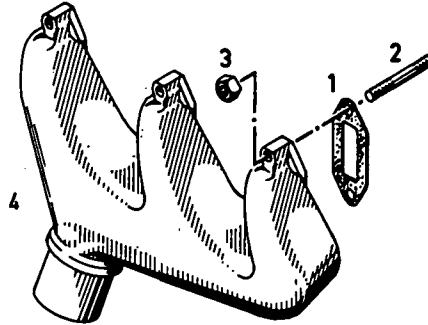

0150-41 500 6822

| Bild-Nr. | Teile-Nr. | Stück-Zahl | Deutsch           | English          | Français            | Español          | Nummer/Bemerkung          | ETK |
|----------|-----------|------------|-------------------|------------------|---------------------|------------------|---------------------------|-----|
| 1        | 337 1689  | 3          | DICHTUNG          | GASKET           | GARNITURE/JOINT     | JUNTA            | 0155-38-20-99             | 01  |
| 2        | 111 0190  | 6          | STIFTSCHRAUBE     | STUD             | GOUJON              | ESPARRAGO        | M 8 X 35 SM9 DIN 835- 8-8 |     |
| 3        | 331 6466  | 6          | SECHSKANTMUTTER   | HEX-NUT          | ECROU 6 PANS        | TUERCA HEXAGONAL | 236 245 D                 | 01  |
| 4        | 336 3913  | 1          | AUSPUFFSAMMELROHR | EXHAUST MANIFOLD | COLLECTEUR D'ECHAPT | COLECTOR ESCAPE  | 0150-41-35-08             |     |

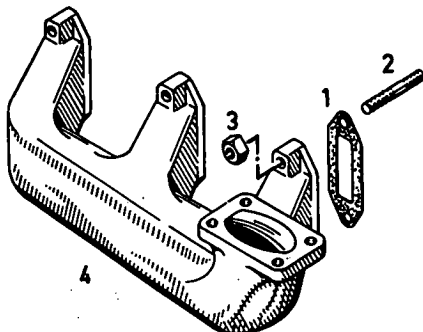

0150-41 500 6830

| Bld<br>Nr. | Teile-Nr. | Stück-<br>Zahl | Deutsch           | English          | Français            | Español          | Nummer/Bemerkung         | ETK |
|------------|-----------|----------------|-------------------|------------------|---------------------|------------------|--------------------------|-----|
| 1          | 337 1687  | 3              | DICHTUNG          | GASKET           | GARNITURE/JOINT     | JUNTA            | 0155-08-20-99            | 01  |
| 2          | 111 0190  | 6              | STIFTSCHRAUBE     | STUD             | GOUJON              | ESPARRAGO        | M 8 X 35 SM4 DIN 835-8-8 |     |
| 3          | 331 6466  | 6              | SECHSKANTMUTTER   | HEX-NUT          | ECROU 6 PANS        | TUERCA HEXAGONAL | 236 245 D                | 01  |
| 4          | 224 2031  | 1              | AUSPUFFSAMMELROHR | EXHAUST MANIFOLD | COLLECTEUR D'ECHAPT | COLECTOR ESCAPE  |                          |     |



Generator  
 Dynamo  
 Dynamo  
 Electrogenerador



0150-44-500 3709

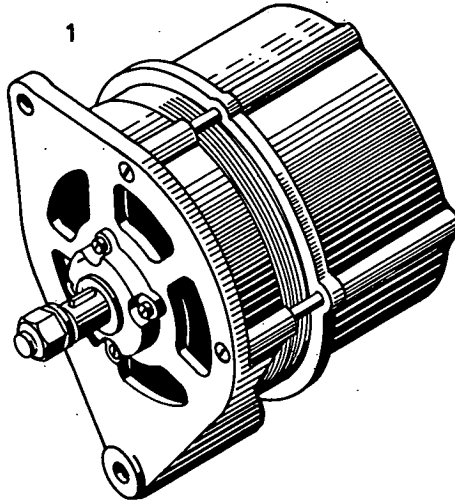

0150-44 500 3709

| Bild Nr. | Teile-Nr. | Stück-Zahl | Deutsch   | English   | Français    | Español   | Nummer/Bemerkung  | ETK |
|----------|-----------|------------|-----------|-----------|-------------|-----------|-------------------|-----|
| 1        | 136 3705  | 1          | GENERATOR | GENERATOR | GENERATRICE | GENERADOR | J 2RL14X 28H 7632 |     |

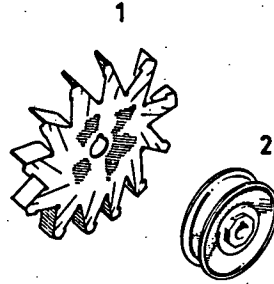

0150-44 500 6888

| Bild Nr. | Teile-Nr. | Stück-Zahl | Deutsch      | English     | Français          | Español      | Nummer/Bemerkung   | ETK |
|----------|-----------|------------|--------------|-------------|-------------------|--------------|--|-----|
| 1        | 116 3984  | 1          | VENTILATOR   | FAN         | VENTILATEUR       | VENTILADOR   | EL6 M 7612   |     |
| 2        | 116 2851  | 1          | RIEMENSCHNUR | BELT PULLEY | POULIE A COURROIE | POLEA CORREA | EK3 M7612<br>1 RILLIG BEI ERSTM-LIEFERUNG<br>POS. 12, 14, 15, 16, 17 AUS BILD-<br>TAFEL 0150-44-500 6917<br>MITLIEFERN |     |



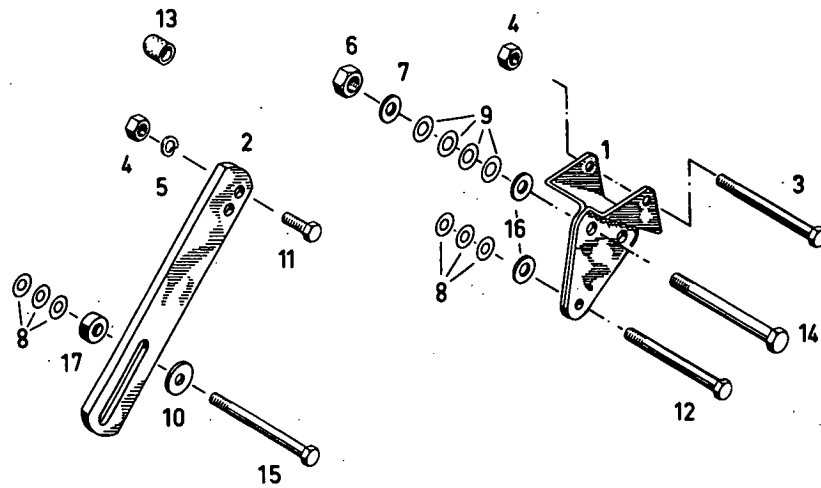

0150-44 500 6917

| Bld Nr. | Teile-Nr. | Stück-Zahl | Deutsch           | English           | Français        | Español            | Nummer/Bemerkung          | ETK |
|---------|-----------|------------|-------------------|-------------------|-----------------|--------------------|---------------------------|-----|
| 14      | 216 6129  | 1          | KONSOLE           | BRACKET/CONSOLE   | CONSOLE         | CONSOLA            |                           |     |
| 2       | 216 6516  | 1          | SPANNLASCHE       | CLAMPING PLATE    | ECLISSE SERRAGE | ECLISA FIADORA     |                           |     |
| 3       | 112 3718  | 1          | SECHSKANTSCHRAUBE | HEX-BOLT          | VIS 6 PANS      | TORNILLO HEXAGONAL | M 8 X 90 DIN 933-10-9     |     |
| 4       | 112 2477  | 2          | SECHSKANMUTTER    | HEX-NUT           | ECROU 6 PANS    | TUERCA HEXAGONAL   | M 8 DIN 934-M10 VZKC      |     |
| 5       | 110 2799  | 1          | FEDERRING         | SPRING LOCKWASHER | RONDELLE GROVER | ARANDELA ELASTICA  | A 8 DIN 128 A4C           |     |
| 6       | 110 2659  | 1          | SECHSKANMUTTER    | HEX-NUT           | ECROU 6 PANS    | TUERCA HEXAGONAL   | M10 DIN 934-M 8 A4C       |     |
| 7       | 110 7105  | 1          | SCHEIBE           | DISC/PANE/PLATE   | RONDELLE/DISQUE | DISCO              | A10-5DIN 125-ST-A4C       |     |
| 8       | 121 5748  | 6          | SCHEIBE           | DISC/PANE/PLATE   | RONDELLE/DISQUE | DISCO              | 995 H 10                  |     |
| 9       | 121 5749  | 4          | SCHEIBE           | DISC/PANE/PLATE   | RONDELLE/DISQUE | DISCO              | 995 H 11                  |     |
| 10      | 121 1206  | 1          | SCHEIBE           | DISC/PANE/PLATE   | RONDELLE/DISQUE | DISCO              | 2 309 A 51                |     |
| 11      | 111 2333  | 1          | SECHSKANTSCHRAUBE | HEX-BOLT          | VIS 6 PANS      | TORNILLO HEXAGONAL | M 8 X 25 DIN 933- 8-8-A4C |     |
| 12      | 111 1200  | 1          | SECHSKANTSCHRAUBE | HEX-BOLT          | VIS 6 PANS      | TORNILLO HEXAGONAL | M 8 X 90 DIN 931- 8-8-A4C |     |
| 13      | 237 2476  | 1          | STOPFEN           | PLUG              | BOUCHON         | TAPON              |                           |     |
| 14      | 111 1345  | 1          | SECHSKANTSCHRAUBE | HEX-BOLT          | VIS 6 PANS      | TORNILLO HEXAGONAL | M10X 90 DIN 931- 8-8-A4C  |     |
| 15      | 112 6479  | 1          | SECHSKANTSCHRAUBE | HEX-BOLT          | VIS 6 PANS      | TORNILLO HEXAGONAL | M 8 X 95 DIN 931- 8-8-A4C |     |
| 16      | 121 6110  | 4          | SCHEIBE           | DISC/PANE/PLATE   | RONDELLE/DISQUE | DISCO              | 2 309 A 15                |     |
| 17      | 336 3977  | 1          | BUECHSE           | BUSH              | BOITE           | CASQUILLO          | 0150-44-25-28             |     |



Schmalkeilriemen  
 Narrow V-belt  
 Courroie trapézoïdale étroite  
 Correa trapecial estrecha

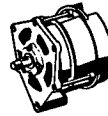

0150-44-500 4562

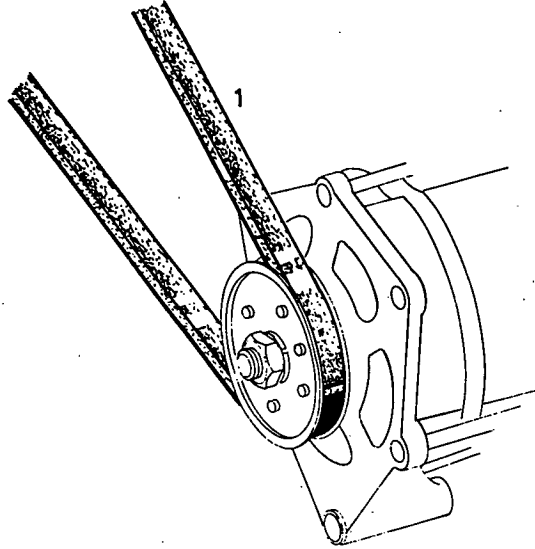

0150-44 500 4562

| Bild Nr. | Teile-Nr. | Stück-Zahl | Deutsch          | English | Français           | Español            | Nummer/Bemerkung | ETK |
|----------|-----------|------------|------------------|---------|--------------------|--------------------|------------------|-----|
| 1        | 117 0652  | 1          | SCHMALKEILRIEMEN | V-BELT  | COURR TRAP ETROITE | CORR-TRAPEC-ESTREC | 9.5X1500H 3701   | 03  |

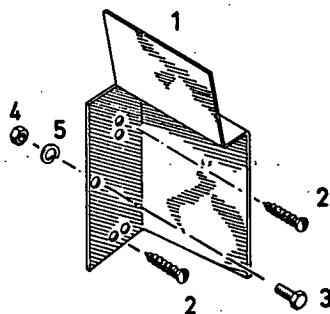

0150-44 500 4567

| Bild Nr. | Teile-Nr. | Stück-Zahl | Deutsch           | English            | Francés         | Español            | Nummer/Bemerkung         | ETK |
|----------|-----------|------------|-------------------|--------------------|-----------------|--------------------|--------------------------|-----|
| 1.       | 216 6522  | 1          | ABSCHIRMBLECH     | SHIELD             | TOLE-ECRAN      | CHAPA PROTECTORA   |                          |     |
| 2.       | 111 9302  | 2          | BLECHSCHRAUBE     | SELF-TAPPING SCREW | VIS             | TORNILLO CHAPA     | B 3.9x 9.5 DIN 7971      |     |
| 3.       | 111 2240  | 1          | SECHSKANTSCHRAUBE | HEX-BOLT           | VIS 6 PANS      | TORNILLO HEXAGONAL | M 6x 12 DIN 933- A-B-A4C |     |
| 4.       | 111 2813  | 1          | SECHSKANTMUTTER   | HEX-NUT            | ECROU 6 PANS    | TUERCA HEXAGONAL   | M 6 DIN 934-M 8 A4C      |     |
| 5.       | 110 2797  | 1          | FEDERRING         | SPRING LOCKWASHER  | RONDELLE GROWER | ARANDELA ELASTICA  | A 6 DIN 128 A4C          |     |

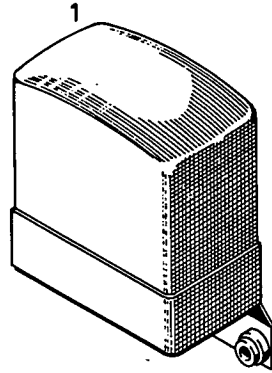

0150-44 500 3706

| Bild-Nr. | Teil-Nr. | Stück-Zahl | Deutsch        | English           | Français          | Español   | Nummer/Bemerkung | ETK |
|----------|----------|------------|----------------|-------------------|-------------------|-----------|------------------|-----|
| 1        | 116 3008 | 1          | REGLERSCHALTER | VOLTAGE REGULATOR | REGUL-DISJONCTEUR | DISYUNTOR | T4H 7635         |     |

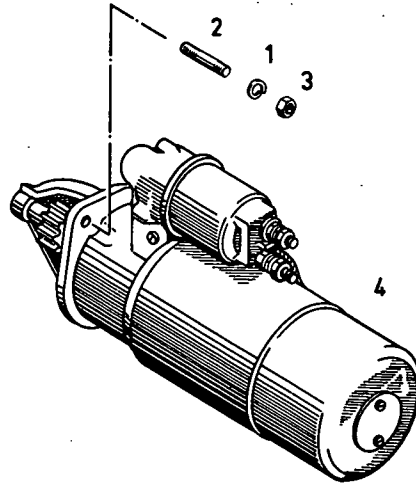
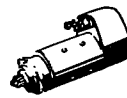

0150-44 500 3651

| Bild Nr. | Teile-Nr. | Stück-Zahl | Deutsch         | English           | Français        | Español           | Nummer/Bemerkung           | ETK |
|----------|-----------|------------|-----------------|-------------------|-----------------|-------------------|----------------------------|-----|
| 1        | 110 2800  | 3          | FEDERRING       | SPRING LOCKWASHER | RONDELLE GROMER | ARANDELA ELASTICA | A 10 DIN 128 A9C           |     |
| 2        | 110 2301  | 3          | STIFTSCHRAUBE   | STUD              | GOIJON          | ESPARRAGO         | AM10X 30 DIN 934- 6-A VZKC |     |
| 3        | 110 2659  | 3          | SECHSKANTMUTTER | HEX-NUT           | ECROU 6 PANS    | TUERCA HEXAGONAL  | M10 DIN 934-M 8 A9C        |     |
| 4        | 116 4994  | 1          | STARTER         | STARTER MOTOR     | DEMARREUR       | ARRANCADOR        | B2BR12X 4 H 7622           |     |

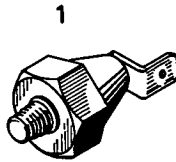

0150-48 500 3752

| Bild-Nr. | Teil-Nr. | Stück-Zahl | Deutsch         | English         | Franciais       | Espanol           | Numer/Bemerkung | ETK |
|----------|----------|------------|-----------------|-----------------|-----------------|-------------------|-----------------|-----|
| 1        | 116 8503 | 1          | ÖLDRUCKSCHALTER | PRESSURE SWITCH | MANO-CONTACTEUR | COMUT-PRES-ACEITE | CHSD H 4207.    |     |



DOPPELKUPPLUNG  
STANDARD DUAL CLUTCH  
EMBRAYAGE DOUBLE EFFET  
EMBRAGUE DOBLE

1002-02 500 5410

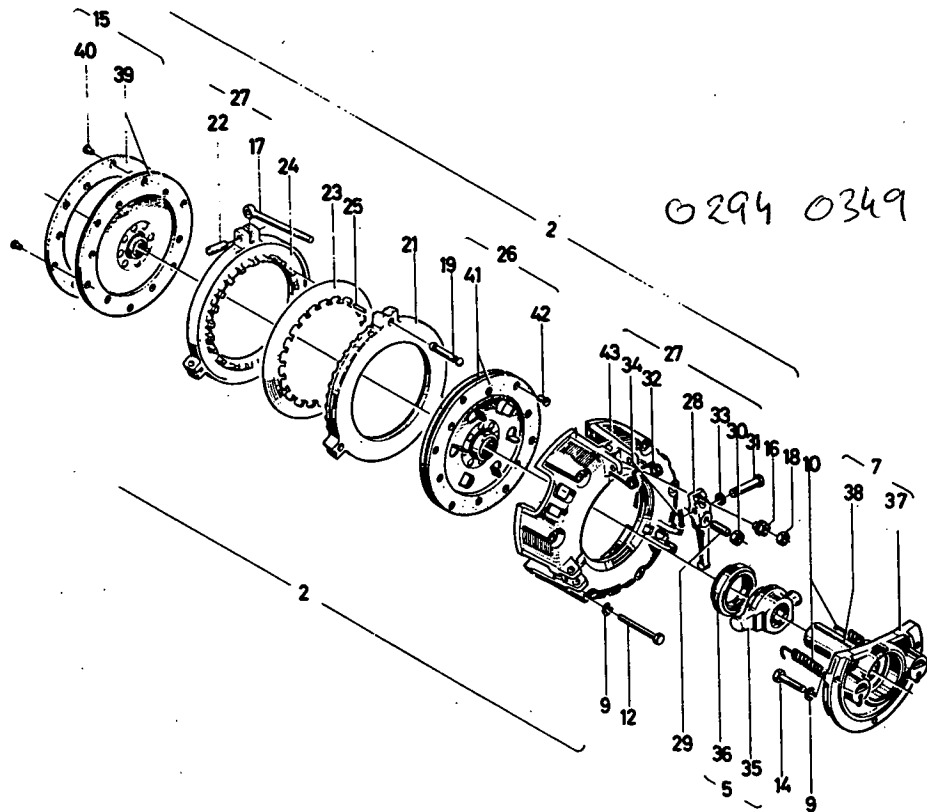

1002-02 500 5410

| Bild-Nr. | Teile-Nr. | Stück-Zahl | Deutsch           | English           | Français           | Español            | Numer/Bemerkung                       | ETK |
|----------|-----------|------------|-------------------|-------------------|--------------------|--------------------|---------------------------------------|-----|
| 2        | 231 6768  | 1          | DOPPELKUPPLUNG    | DUAL CLUTCH       | EMBRAYAGE BIDISQUE | EMBRAGUE DOBLE     | <i>not sell</i><br>KPL.-M. POS. 15-34 |     |
| 5        | 232 0779  | 1          | AUSRUECKER        | DISENGAGER        | DEBRAYEUR          | DESEMBRAGADOR      |                                       |     |
| 7        | 232 0780  | 1          | FLANSCHBUCHSE     | FLANGED BUSH      | DOUILLE A BRIDE    | CASQUILLO BRIDA    |                                       |     |
| 9        | 110 2799  | 9          | FEDERRING         | SPRING LOCKWASHER | RONDELLE GROMER    | ARANDELA ELASTICA  | A 8 DIN 128 A4C                       |     |
| 10       | 338 9261  | 2          | ZUGFEDER          | DRAW SPRING       | RESSORT TRACTION   | RESORTE TRACCION   | 1145-02-01-06                         | 01  |
| 12       | 111 1195  | 6          | SECHSKANTSCHRAUBE | HEX-BOLT          | VIS 6 PANS         | TORNILLO HEXAGONAL | M 8X 95 DIN 931- 8-8                  |     |
| 14       | 111 2331  | 3          | SECHSKANTSCHRAUBE | HEX-BOLT          | VIS 6 PANS         | TORNILLO HEXAGONAL | M 8X 25 DIN 933- 8-8                  |     |
| 15       | 230 7628  | 1          | KUPPLUNGSSCHEIBE  | DISC              | DISQUE D EMBRAYAGE | PLATO EMBRAGUE     | 8216, MOTORSEITIG                     | 01  |
| 16       | 230 9648  | 3          | EINSTELLMUTTER    | ADJUSTING NUT     | ECROU DE REGLAGE   | TUERCA GRADUAC.    |                                       |     |
| 17       | 230 9650  | 3          | AUGENSCHRAUBE     | EYE SCREW         | PITON FILETE       | CANCAMO ROSCADO    |                                       |     |
| 18       | 112 6748  | 3          | SECHSKANTMUTTER   | HEX-NUT           | ECROU 6 PANS       | TUERCA HEXAGONAL   | 8M 80DIN 939-55                       |     |
| 19       | 230 9653  | 3          | HEBEL             | LEVER/ARM         | LEVIER             | PALANCA            |                                       |     |
| 21       | 230 9655  | 1          | ANPRESSPLATTE     | PRESSURE PLATE    | PLAQUE DE PRESSION | PLATO DE PRESION   |                                       |     |
| 22       | 230 9657  | 3          | BOLZEN            | PIN/BOLT/STUD     | BOULON/AXE         | BULON              |                                       |     |
| 23       | 230 7639  | 1          | TELLERFEDER       | CUP SPRING        | RESSORT BELLEVILLE | RESORTE DE PLATO   |                                       |     |
| 24       | 230 9658  | 1          | ANPRESSPLATTE     | PRESSURE PLATE    | PLAQUE DE PRESSION | PLATO DE PRESION   |                                       |     |
| 25       | 111 5435  | 3          | SPANNHUELSE       | DOWEL SLEEVE      | DOUILLE SERRAGE    | CASQUILLO FIADOR   | 4 X 12DIN 1481                        |     |
| 26       | 231 6746  | 1          | KUPPLUNGSSCHEIBE  | DISC              | DISQUE D EMBRAYAGE | PLATO EMBRAGUE     | 8142, SETRIEBSEITIG                   | 01  |
| 27       | 232 2947  | SZ         | HEBEL             | LEVER/ARM         | LEVIER             | PALANCA            |                                       |     |
| 28       | 230 9647  | IP         | HEBEL             | LEVER/ARM         | LEVIER             | PALANCA            | 8285, SIEHE POS. 27                   |     |
| 29       | 230 9656  | 3          | GEWINDEBOLZEN     | THREADED PIN      | BOULON FILETE      | BULON ROSCADO      |                                       |     |
| 30       | 230 9649  | 3          | SECHSKANTMUTTER   | HEX-NUT           | ECROU 6 PANS       | TUERCA HEXAGONAL   |                                       |     |
| 31       | 230 7055  | 3          | BOLZEN            | PIN/BOLT/STUD     | BOULON/AXE         | BULON              |                                       |     |
| 32       | 230 9652  | 3          | FEDER             | SPRING            | RESSORT            | RESORTE/BALLESTA   |                                       |     |

| Bld<br>Nr. | Teil-Nr. | Stück-<br>Zahl | Deutsch          | English         | Français           | Español            | Nummer/Bemerkung | ETK |
|------------|----------|----------------|------------------|-----------------|--------------------|--------------------|------------------|-----|
| 33         | 111 5036 | 6              | UNTERLEGSCHIEBE  | WASHER          | RONDELLE           | ARANDELA CALCE     | 9DIN 1441        |     |
| 34         | 110 6427 | 6              | SPLINT           | SPLIT PIN       | GOUPILLE FENDUE    | PASADOR ALETAS     | 3 X 15DIN 94     |     |
| 35         | 231 2574 | 1              | GEHÄUSE          | HOUSING/CASE    | CARTER/BOITIER     | CAJA/BLOQUE/CUERPO |                  |     |
| 36         | 126 6401 | 1              | LAGER            | BEARING/SUPPORT | PALIER/SUPPORT     | SOPORTE/COJINETE   | 8739-44-08-20    | 01  |
| 37         | 231 2565 | 1              | FLANSCH          | FLANGE          | BRIDE/COLLET       | BRIDA              |                  |     |
| 38         | 231 1319 | 1              | ROHR             | PIPE/TUBE       | TUBE/TUYAU         | TUBO               |                  |     |
| 39         | 230 7627 | 2              | KUPPLUNGSBELAG   | CLUTCH LINING   | GARNITURE EMBRAY   | FORRO EMBRAGUE     |                  | 01  |
| 40         | 230 7623 | 12             | NIET             | RIVET           | RIVET              | RENACHE            |                  | 01  |
| 41         | 231 4627 | 2              | KUPPLUNGSBELAG   | CLUTCH LINING   | GARNITURE EMBRAY   | FORRO EMBRAGUE     |                  | 01  |
| 42         | 231 4628 | 16             | NIET             | RIVET           | RIVET              | RENACHE            |                  | 01  |
| 43         | 230 9654 | 1              | KUPPLUNGSGEHÄUSE | CLUTCH HOUSING  | CARTER D EMBRAYAGE | CAJA EMBRAGUE      |                  |     |



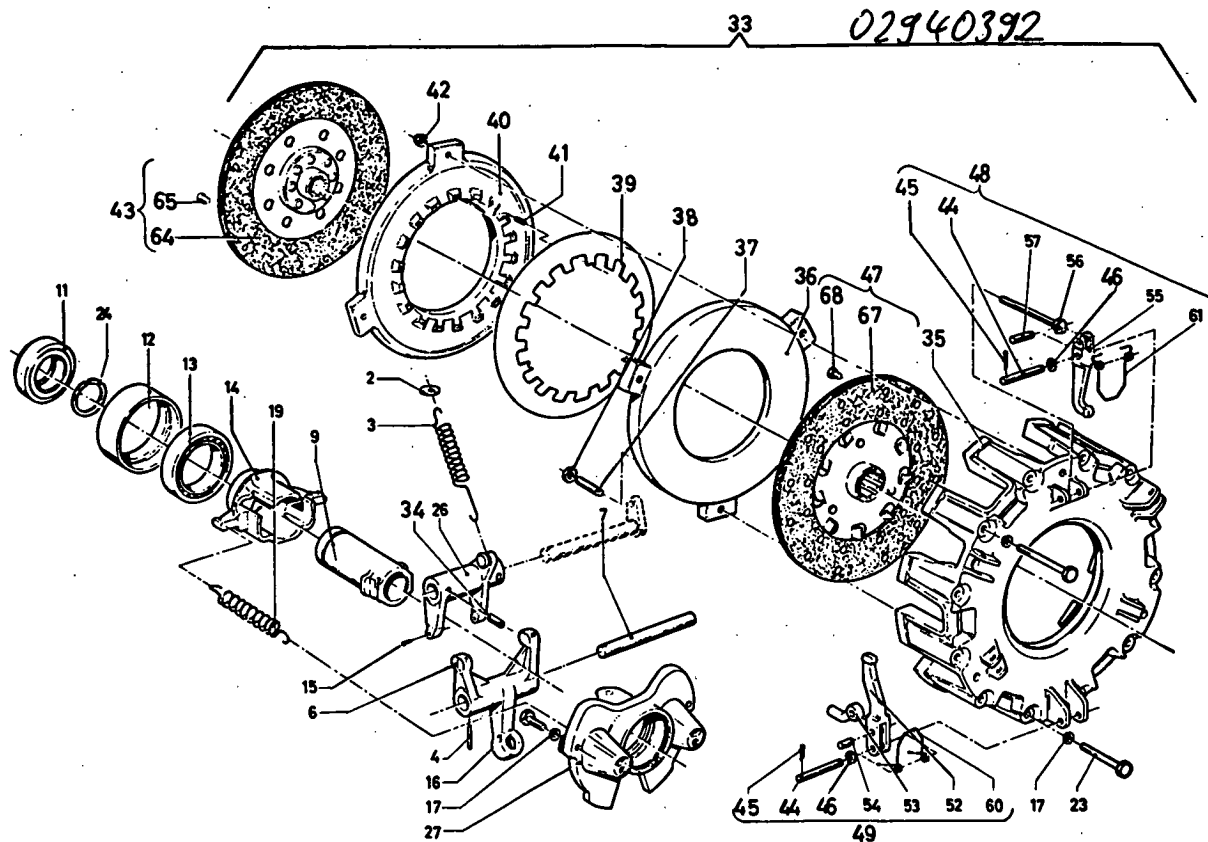

1005-02 500 4180

| Bld. Nr. | Teil-Nr. | Stück-Zahl | Deutsch           | English           | Français            | Español            | Nummer/Bemerkung          | ETK |
|----------|----------|------------|-------------------|-------------------|---------------------|--------------------|---------------------------|-----|
| 2        | 230 5289 | 1          | SCHEIBE           | DISC/PLATE        | RONDELLE/DISQUE     | DISCO              |                           |     |
| 3        | 230 5290 | 1          | ZUGFEDER          | DRAW SPRING       | RESSORT TRACTION    | RESORTE TRACCION   |                           | 01  |
| 4        | 111 5443 | 1          | SPANNHUELSE       | DOWEL SLEEVE      | DOUILLE SERRAGE     | CASQUILLO FIADOR   | 5 X 40 DIN 1463           |     |
| 6        | 230 5291 | 1          | HEBEL             | LEVER/ARM         | LEVIER              | PALANCA            |                           |     |
| 7        | 230 5293 | 1          | BOLZEN            | PIN/BOLT/STUD     | BOULON/AXE          | BULON              |                           |     |
| 9        | 230 5296 | 1          | GEHAEUSE          | HOUSING/CASE      | CARTER/BOITIER      | CAJA/BLOQUE/CUERPO |                           |     |
| 11       | 126 0070 | 1          | LAGER             | BEARING/SUPPORT   | PALIER/SUPPORT      | SOPORTE/COJINETE   |                           | 01  |
| 12       | 230 5298 | 1          | RING              | RING              | BAGUE/ANNEAU        | ANILLO             |                           |     |
| 13       | 110 1461 | 1          | RILLENKUGELLAGER  | BALL BEARING      | ROUL. RAINURE BILLE | COJ.-BOLAS FIJO    | 6014-2RS DIN 625          | 01  |
| 14       | 230 5299 | 1          | GEHAEUSE          | HOUSING/CASE      | CARTER/BOITIER      | CAJA/BLOQUE/CUERPO |                           |     |
| 15       | 111 5433 | 2          | SPANNHUELSE       | DOWEL SLEEVE      | DOUILLE SERRAGE     | CASQUILLO FIADOR   | 5 X 36 DIN 1463           |     |
| 16       | 111 2341 | 3          | SECHSKANTSCHRAUBE | HEX-BOLT          | VIS 6 PANS          | TORNILLO HEXAGONAL | M 8 X 30 DIN 933- 2-2-A4C |     |
| 17       | 110 2799 | 7          | FEDERRING         | SPRING LOCKWASHER | RONDELLE GROMER     | ARANDELA ELASTICA  | A 8 DIN 128 A4C           |     |
| 19       | 338 9261 | 2          | ZUGFEDER          | DRAW SPRING       | RESSORT TRACTION    | RESORTE TRACCION   | 1145-02-01-06             | 01  |
| 23       | 112 2399 | 6          | SECHSKANTSCHRAUBE | HEX-BOLT          | VIS 6 PANS          | TORNILLO HEXAGONAL | M 8 X 85 DIN 931- 2-2-A4C |     |
| 24       | 121 0673 | 1          | SPRENGRING        | SNAP RING         | AGRAFE CIRCULAIRE   | ANILLO RETENCION   | 2 260 B 13                | 01  |
| 26       | 233 9255 | 1          | HEBEL             | LEVER/ARM         | LEVIER              | PALANCA            |                           |     |
| 27       | 231 1778 | 1          | BUECHSE           | BUSH              | BOITE               | CASQUILLO          |                           |     |
| 33       | 231 6769 | 1          | DOPPELKUPPLUNG    | DUAL CLUTCH       | EMBRAYAGE BIDISQUE  | EMBRAGUE DOBLE     |                           |     |
| 34       | 111 5460 | 2          | SPANNHUELSE       | DOWEL SLEEVE      | DOUILLE SERRAGE     | CASQUILLO FIADOR   | 6 X 45 DIN 1463 VZKC      |     |
| 35       | 230 7637 | 1          | KUPPLUNGSGEHAEUSE | CLUTCH HOUSING    | CARTER D EMBRAYAGE  | CAJA EMBRAGUE      |                           |     |
| 36       | 230 7638 | 1          | ANPRESSPLATTE     | PRESSURE PLATE    | PLAQUE DE PRESSION  | PLATO DE PRESSION  |                           |     |
| 37       | 231 3920 | 3          | GEWINDESTIFT      | GRUE SCREW        | GOUPILLE FILETEE    | PERNO ROSCADO      |                           |     |
| 38       | 112 6749 | 3          | SECHSKANTMUTTER   | HEX-NUT           | ECROU 6 PANS        | TUERCA HEXAGONAL   | M10 DIN 934-SS-A4C        |     |
| 39       | 230 7639 | 1          | TELLERFEDER       | CUP SPRING        | RESSORT BELLEVILLE  | RESORTE DE PLATO   |                           |     |
| 40       | 230 7640 | 1          | ANPRESSPLATTE     | PRESSURE PLATE    | PLAQUE DE PRESSION  | PLATO DE PRESSION  |                           |     |

| Bild Nr. | Teil-Nr. | Stück-Zahl | Deutsch          | English       | Français           | Español          | Nummer/Bemerkung    | ET |
|----------|----------|------------|------------------|---------------|--------------------|------------------|---------------------|----|
| 41       | 111 5415 | 1          | SPANNHUELSE      | DOWEL SLEEVE  | DOUILLE SERRAGE    | CASQUILLO FIADOR | 4 X 12DIN 1481      |    |
| 42       | 230 7064 | 3          | EINSTELLNUTTER   | ADJUSTING NUT | ECROU DE REGLAGE   | TUERCA GRADUAC-  |                     |    |
| 43       | 230 7628 | 1          | KUPPLUNGSSCHEIBE | DISC          | DISQUE D EMBRAYAGE | PLATO EMBRAGUE   | 8216-MOTORSEITIG    | 01 |
| 44       | 230 7055 | 6          | BOLZEN           | PIN/BOLT/STUD | BOULON/AXE         | BULON            |                     |    |
| 45       | 110 6427 | 6          | SPLINT           | SPLIT PIN     | GOUPILLE FENDUE    | PASADOR ALETAS   | 3 X 15DIN 99        |    |
| 46       | 111 5036 | 12         | UNTERLEGSCHEIBE  | WASHER        | RONDILLE           | ARANDELA CALCE   | 9DIN 1441           |    |
| 47       | 231 6746 | 1          | KUPPLUNGSSCHEIBE | DISC          | DISQUE D EMBRAYAGE | PLATO EMBRAGUE   | 8142-GETRIEBESEITIG | 01 |
| 48       | 232 2741 | SZ         | HEBEL            | LEVER/ARM     | LEVIER             | PALANCA          | 8216-MOTORSEITIG    |    |
| 49       | 232 2743 | SZ         | HEBEL            | LEVER/ARM     | LEVIER             | PALANCA          | 8142-GETRIEBESEITIG |    |
| 52       | 230 7641 | IP         | HEBEL            | LEVER/ARM     | LEVIER             | PALANCA          | 8285-SIEHE POS-49   |    |
| 53       | 231 3419 | IP         | HEBEL            | LEVER/ARM     | LEVIER             | PALANCA          | 8285-SIEHE POS-49   |    |
| 54       | 230 7630 | 3          | BOLZEN           | PIN/BOLT/STUD | BOULON/AXE         | BULON            |                     |    |
| 55       | 230 7631 | IP         | HEBEL            | LEVER/ARM     | LEVIER             | PALANCA          | 8285-SIEHE POS-48   |    |
| 56       | 230 7632 | 3          | AUGENSCHRAUBE    | EYE SCREW     | PITON FILETE       | CANCARO ROSCADO  |                     |    |
| 57       | 230 7633 | 3          | BOLZEN           | PIN/BOLT/STUD | BOULON/AXE         | BULON            |                     |    |
| 60       | 230 7636 | 3          | FEDER            | SPRING        | RESSORT            | RESORTE/BALLESTA |                     |    |
| 61       | 230 7635 | 3          | FEDER            | SPRING        | RESSORT            | RESORTE/BALLESTA |                     |    |
| 64       | 230 7627 | 2          | KUPPLUNGSBELAG   | CLUTCH LINING | GARNITURE EMBRAY   | FORRO EMBRAGUE   |                     | 01 |
| 65       | 230 7623 | 24         | NIET             | RIVET         | RIVET              | RENACHE          |                     | 01 |
| 67       | 231 4627 | 2          | KUPPLUNGSBELAG   | CLUTCH LINING | GARNITURE EMBRAY   | FORRO EMBRAGUE   |                     | 01 |
| 68       | 231 4628 | 32         | NIET             | RIVET         | RIVET              | RENACHE          |                     | 01 |

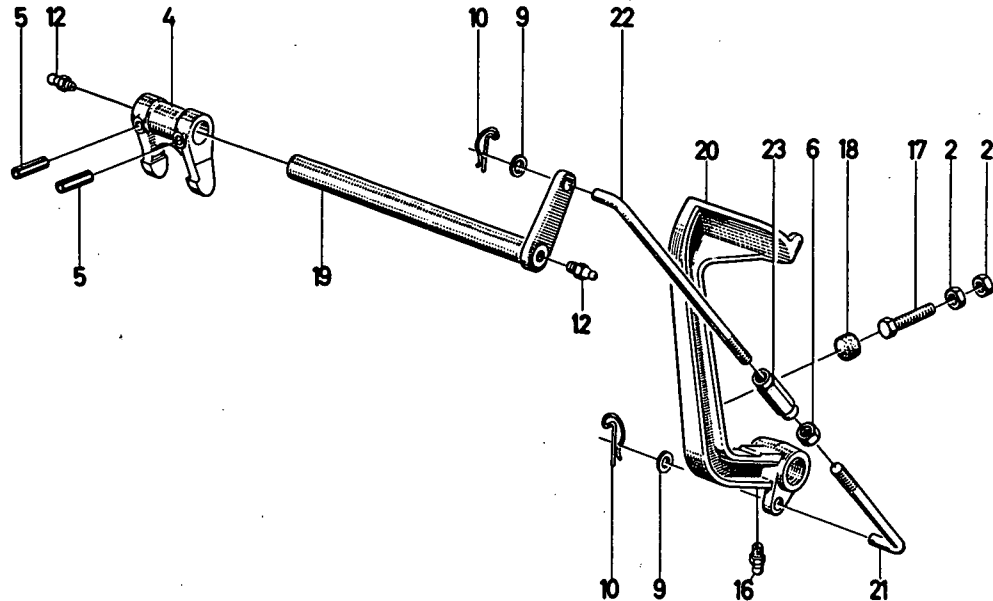

1001-03 500 6096

| Bld Nr. | Teile-Nr. | Stück-Zahl | Deutsch            | English         | Français          | Español            | Nummer/Bemerkung         | ETK |
|---------|-----------|------------|--------------------|-----------------|-------------------|--------------------|--------------------------|-----|
| 2       | 110 2659  | 2          | SECHSKANTMUTTER    | HEX-NUT         | ECROU 6 PANS      | TUERCA HEXAGONAL   | M10 DIN 934-M 8 A4C      |     |
| 4       | 232 0760  | 1          | GABELHEBEL         | FORKED LEVER    | LEVIER A CHAPE    | PALANCA HORQUILLA  |                          |     |
| 5       | 111 5459  | 2          | SPANNHUELSE        | DOVEL SLEEVE    | DOUILLE SERRAGE   | CASQUILLO FIADOR   | 6 X 45DIN 1481           |     |
| 6       | 111 3152  | 1          | SECHSKANTMUTTER    | HEX-NUT         | ECROU 6 PANS      | TUERCA HEXAGONAL   | M12 DIN 936-M55-A4C      |     |
| 9       | 110 7554  | 2          | SCHIEBE            | DISC/PANE/PLATE | RONDELLE/DISQUE   | DISCO              | 13-50DIN 433-ST-A4C      |     |
| 10      | 336 7776  | 2          | STECKSTUECK        | PLUG            | PIECE A ENFICHER  | PIEZA ENCHUFE      | 1125-30-01-16            | 01  |
| 12      | 116 8224  | 2          | KEGELSCHMIERNIPPEL | LUBE FITTING    | GRAISSEUR CONIQUE | ENGRASADOR CONICO  | SA 64 3360               |     |
| 16      | 116 8225  | 1          | KEGELSCHMIERNIPPEL | LUBE FITTING    | GRAISSEUR CONIQUE | ENGRASADOR CONICO  | SA 84 3360               |     |
| 17      | 111 2470  | 1          | SECHSKANTSCHRAUBE  | HEX-BOLT        | VIS 6 PANS        | TORNILLO HEXAGONAL | M10X 50 DIN 933- 8-8-A4C |     |
| 18      | 233 0268  | 1          | GUMMIPUFFER        | RUBBER PAD      | TAMPON CAOUTCHOUC | TOPE CAUCHO        |                          | 01  |
| 19      | 233 1289  | 1          | KUPPLUNGSWELLE     | SHAFT           | ARBRE D EMBRAYAGE | EJE EMBRAGUE       |                          |     |
| 20      | 233 0793  | 1          | KUPPLUNGSPEDAL     | CLUTCH PEDAL    | PEDALE D EMBRAY   | PEDAL EMBRAGUE     |                          |     |
| 21      | 237 0844  | 1          | ZUGSTANGE          | PULLROD         | TIRANT            | BARRA TRACCION     |                          |     |
| 22      | 230 9298  | 1          | ZUGSTANGE          | PULLROD         | TIRANT            | BARRA TRACCION     |                          |     |
| 23      | 111 5363  | 1          | SPANNSCHLOSSMUTTER | TURNBUCKLE      | ECROU TENDEUR     | TUERCA CIERRE TENS | M12DIN 1479 V2KC         |     |

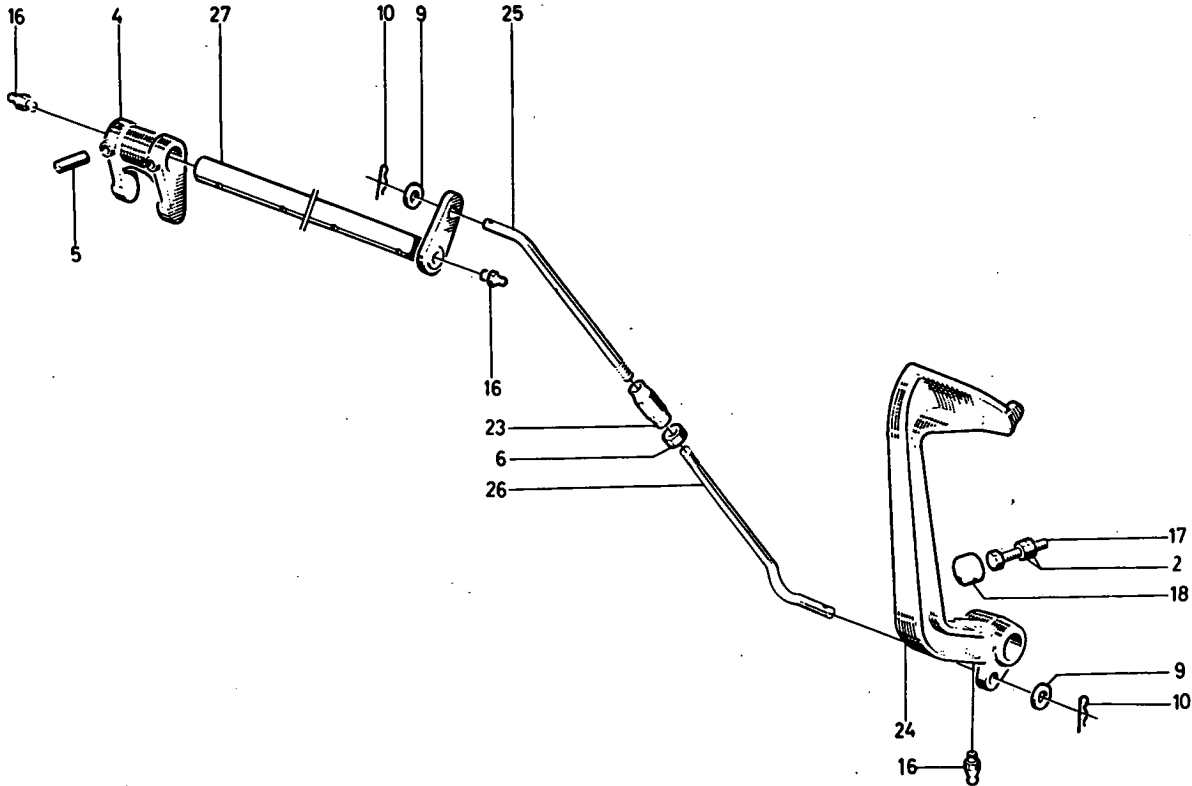

1001-03 500 5411

| Bild Nr. | Teil-Nr. | Stück-Zahl | Deutsch            | English         | Français           | Español            | Nummer/Bemerkung         | ETK |
|----------|----------|------------|--------------------|-----------------|--------------------|--------------------|--------------------------|-----|
| 2        | 110 2659 | 2          | SECHSKANTMUTTER    | HEX-NUT         | ECROU 6 PANS       | TUERCA HEXAGONAL   | M10 DIN 934-M 8 A4C      |     |
| 4        | 232 0760 | 1          | GABELHEBEL         | FORKED LEVER    | LEVIER A CHAPE     | PALANCA HORQUILLA  |                          |     |
| 5        | 111 5459 | 2          | SPANNBUCHSE        | CLAMPING BUSH   | DOUILLE DE SERRAGE | CASQUILLO FIADOR   | 6 X 45DIN 1481           |     |
| 6        | 111 2658 | 1          | SECHSKANTMUTTER    | HEX-NUT         | ECROU 6 PANS       | TUERCA HEXAGONAL   | M12 DIN 934-M 8 A4C      |     |
| 7        | 110 7554 | 2          | SCHEIBE            | DISC/PANE/PLATE | RONDELLE/DISQUE    | DISCO              | 13.5DIN 433-ST-A4C       |     |
| 10       | 338 7776 | 2          | SICHERUNGSTIFT     | LOCKING PIN     | GOUPILLE D ARRET   | PERNO AFIANZADOR   |                          | 01  |
| 16       | 116 8225 | 3          | KEGELSCHMIERNIPPEL | LUBE FITTING    | GRAISSEUR CONIQUE  | ENGRASADOR CONICO  | SA 8H 3360               |     |
| 17       | 111 2470 | 1          | SECHSKANTSCHRAUBE  | HEX-BOLT        | VIS 6 PANS         | TORNILLO HEXAGONAL | M10X 80 DIN 933- 8-8-A4C |     |
| 18       | 233 0268 | 1          | GUMMIPUFFER        | RUBBER PAD      | TAMPON CAOUTCHOUC  | TOPE CAUCHO        |                          | 01  |
| 23       | 111 5363 | 1          | SPANNSCHLOSSMUTTER | TURNBUCKLE      | ECROU TENDEUR      | TUERCA CIERRE TENS | M12DIN 1479 VZKC         |     |
| 24       | 237 0872 | 1          | KUPPLUNGSPEDAL     | CLUTCH PEDAL    | PEDALE D EMBRAY    | PEDAL EMBRAGUE     |                          |     |
| 25       | 237 0832 | 1          | ZUGSTANGE          | PULLROD         | TIRANT             | BARRA TRACCION     |                          |     |
| 26       | 237 0833 | 1          | ZUGSTANGE          | PULLROD         | TIRANT             | BARRA TRACCION     |                          |     |
| 27       | 238 1948 | 1          | KUPPLUNGSWELLE     | SHAFT           | ARBRE D EMBRAYAGE  | EJE EMBRAGUE       |                          |     |



BETÄTIGUNG ZUR DOPPELKUPPLUNG (UNABHÄNGIG)  
 IPTO DUAL CLUTCH CONTROL ASSEMBLY  
 COMMANDE DE L'EMBRAYAGE BI-DISQUE EN PRESENCE D'UNE PRISE DE FORCE AUTONOME  
 ACCIONAMIENTO DEL EMBRAGUE DOBLE (INDEPENDIENTE)

7868/0131  
 1005-03 500 6097

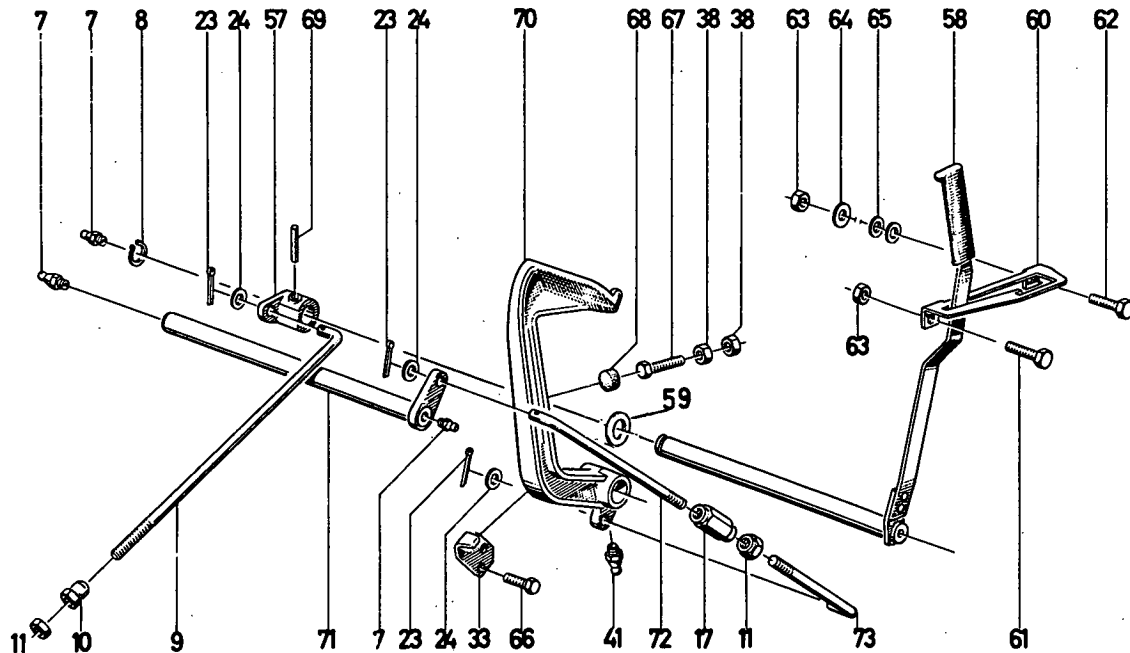

1005-03 500 6097

| Bild Nr. | Teil-Nr. | Stück-Zahl | Deutsch            | English         | Français           | Español             | Numer/Bemerkung           | ETK |
|----------|----------|------------|--------------------|-----------------|--------------------|---------------------|---------------------------|-----|
| 7        | 116 8224 | 4          | KEGELSCHMIERNIPPEL | LUBE FITTING    | GRAISSEUR CONIQUE  | ENGRASADOR CONICO   | SA 64 3360                |     |
| 8        | 110 7737 | 1          | SICHERUNGSRING     | CIRCLIP         | CIRCLIP            | CIRCLIP             | 25X1,2 DIN 471            |     |
| 9        | 230 6705 | 1          | ZUGSTANGE          | PULLROD         | TIRANT             | BARRA TRACCION      |                           |     |
| 10       | 230 5367 | 1          | KUGELBUNDMUTTER    | SHOULDER NUT    | ECROU COLLET SPHER | TUERCA-COLLAR-ESFER |                           |     |
| 11       | 111 3152 | 2          | SECHSKANTMUTTER    | HEX-NUT         | ECROU 6 PANS       | TUERCA HEXAGONAL    | M12 DIN 936-M55-A4C       |     |
| 17       | 111 5363 | 1          | SPANNSCHLOSSMUTTER | TURNBUCKLE      | ECROU TENDEUR      | TUERCA CIERRE TENS  | M12D14 1479 VZKC          |     |
| 23       | 110 6447 | 3          | SPLINT             | SPLIT PIN       | GOUVILLE FENDUE    | PASADOR ALETAS      | 4 X 20DIN 94-A4C          |     |
| 24       | 110 7554 | 3          | SCHEIBE            | DISC/PANE/PLATE | RONDELLE/DISQUE    | DISCO               | 13,5DIN 433-ST-A4C        |     |
| 33       | 231 2588 | 1          | ANSCHLAG           | STOP            | BUTEE              | TOPE                |                           |     |
| 38       | 110 2659 | 2          | SECHSKANTMUTTER    | HEX-NUT         | ECROU 6 PANS       | TUERCA HEXAGONAL    | M10 DIN 934-M 8 A4C       |     |
| 41       | 116 8225 | 1          | KEGELSCHMIERNIPPEL | LUBE FITTING    | GRAISSEUR CONIQUE  | ENGRASADOR CONICO   | SA 84 3360                |     |
| 57       | 233 2798 | 1          | HEBEL              | LEVER/ARM       | LEVIER             | PALANCA             |                           |     |
| 58       | 233 0271 | 1          | KUPPLUNGHEBEL      | CLUTCH LEVER    | LEVIER D EMBRAYAGE | PALANCA EMBRAGUE    |                           |     |
| 59       | 233 0166 | 1          | SCHEIBE            | DISC/PANE/PLATE | RONDELLE/DISQUE    | DISCO               |                           |     |
| 60       | 233 0180 | 1          | SCHALKULISSE       | SHIFT GATE      | COULISSE           | PLACA GUIA CAMBIO   |                           |     |
| 61       | 111 2305 | 1          | SECHSKANTSCHRAUBE  | HEX-BOLT        | VIS 6 PANS         | TORNILLO HEXAGONAL  | M 8 X 15 DIN 933- 8-8-A4C |     |
| 62       | 111 2326 | 1          | SECHSKANTSCHRAUBE  | HEX-BOLT        | VIS 6 PANS         | TORNILLO HEXAGONAL  | M 8 X 22 DIN 933- 8-8-A4C |     |
| 63       | 110 8064 | 1          | SECHSKANTMUTTER    | HEX-NUT         | ECROU 6 PANS       | TUERCA HEXAGONAL    | M 8 DIN 555 VZKC          |     |
| 64       | 339 0951 | 1          | SCHEIBE            | DISC/PANE/PLATE | RONDELLE/DISQUE    | DISCO               | 1171-49-01-55             |     |
| 65       | 110 7163 | 2          | SCHEIBE            | DISC/PANE/PLATE | RONDELLE/DISQUE    | DISCO               | 9,5SD14 126-A4C           |     |
| 66       | 111 2412 | 2          | SECHSKANTSCHRAUBE  | HEX-BOLT        | VIS 6 PANS         | TORNILLO HEXAGONAL  | M10X 22 DIN 933- 8-8-A4C  |     |
| 67       | 111 2466 | 1          | SECHSKANTSCHRAUBE  | HEX-BOLT        | VIS 6 PANS         | TORNILLO HEXAGONAL  | M10X 65 DIN 933- 8-8-A4C  |     |
| 68       | 233 0268 | 1          | GUMMIPUFFER        | RUBBER PAD      | TAMPON CAOUTCHOUC  | TOPE CAUCHO         |                           |     |
| 69       | 111 5461 | 1          | SPANNKEGEL         | CLAMPING CONE   | CONE DE SERRAGE    | CONO FIADOR         | 6 X 50DIN 1481            |     |
| 70       | 233 0793 | 1          | KUPPLUNGSPEDAL     | CLUTCH PEDAL    | PEDALE D EMBRAY    | PEDAL EMBRAGUE      |                           |     |

| Bild<br>Nr. | Teile-Nr. | Stück-<br>Zahl | Deutsch        | English | Francés           | Español        | Nummer / Bemerkung | ETK |
|-------------|-----------|----------------|----------------|---------|-------------------|----------------|--------------------|-----|
| 71          | 233 1294  | 1              | KUPPLUNGSWELLE | SHAFT   | ARBRE D EMBRAYAGE | EJE EMBRAGUE   |                    |     |
| 72          | 230 9298  | 1              | ZUGSTANGE      | PULLROD | TIRANT            | BARRA TRACCION |                    |     |
| 73          | 237 0844  | 1              | ZUGSTANGE      | PULLROD | TIRANT            | BARRA TRACCION |                    |     |



BETÄTIGUNG ZUR DOPPELKUPPLUNG (UNABHÄNGIG)  
 IPTO DUAL CLUTCH CONTROL ASSEMBLY  
 COMMANDE DE L'EMBRAYAGE BI-DISQUE EN PRESENCE D'UNE PRISE DE FORCE AUTONOME  
 ACCIONAMIENTO DEL EMBRAGUE DOBLE (INDEPENDIENTE)

1005-03 500 4181

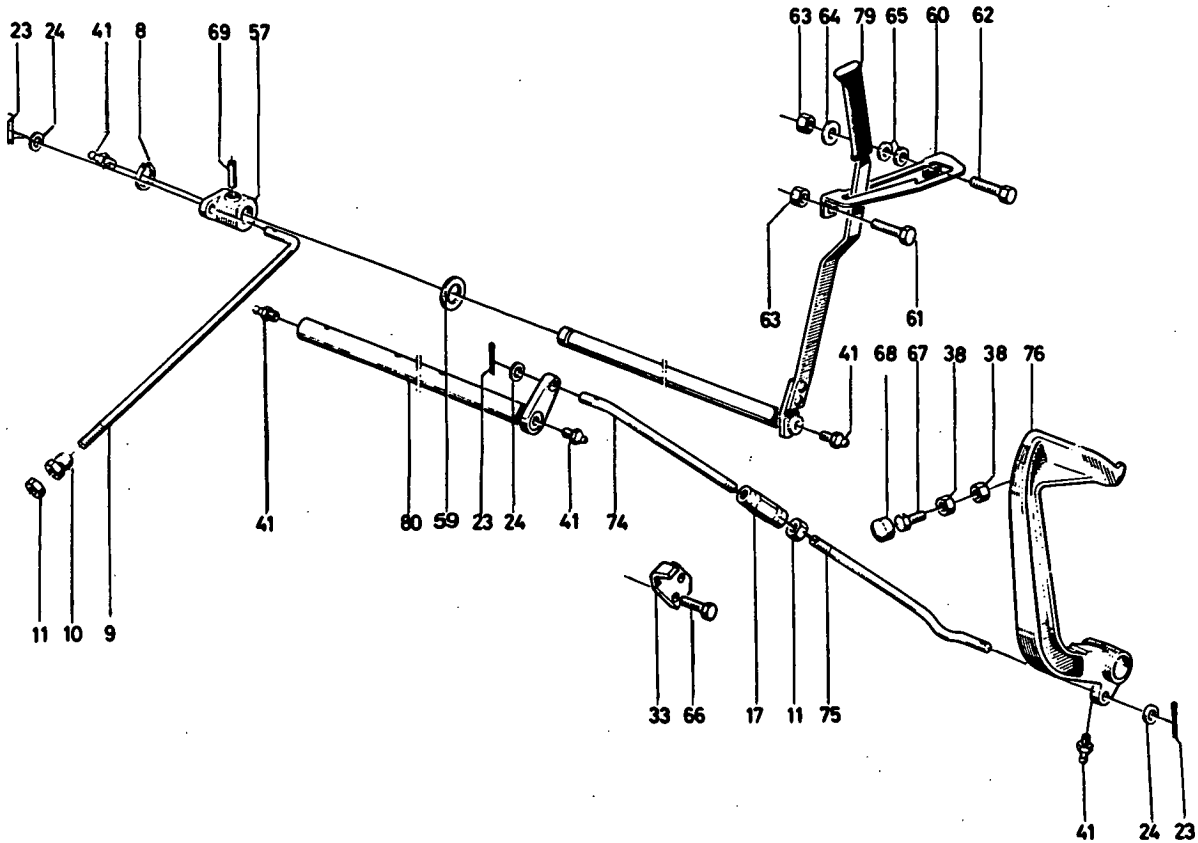

| Bld. Nr. | Teil-Nr. | Stück-Zahl | Deutsch            | English         | Français           | Español            | Nummer/Bemerkung          | ETK |
|----------|----------|------------|--------------------|-----------------|--------------------|--------------------|---------------------------|-----|
| 8        | 110 7737 | 1          | SICHERUNGSRING     | CIRCLIP         | CIRCLIP            | CIRCLIP            | 25X1,2 DIN 471            |     |
| 9        | 230 6705 | 1          | ZUGSTANGE          | PULLROD         | TIRANT             | BARRA TRACCION     |                           |     |
| 10       | 230 5367 | 1          | KUGELMUTTER        | DOMED NUT       | ECROU SPHERIQUE    | TUERCA ESFERICA    |                           |     |
| 11       | 111 3152 | 2          | SECHSKANTMUTTER    | HEX-NUT         | ECROU 6 PANS       | TUERCA HEXAGONAL   | M12 DIN 934-MSS VZKC      |     |
| 17       | 111 5363 | 1          | SPANNSCHLOSSMUTTER | TURNBUCKLE      | ECROU TENDEUR      | TUERCA CIERRE TENS | M12 DIN 1479 VZKC         |     |
| 23       | 110 6447 | 3          | SPLINT             | SPLIT PIN       | GOUPILLE FENDUE    | PASADOR ALETAS     | 4 X 20 DIN 94-A4C         |     |
| 24       | 110 7554 | 3          | SCHEIBE            | DISC/PANE/PLATE | RONDELLE/DISQUE    | DISCO              | 13,5 DIN 433-ST-A4C       |     |
| 33       | 231 2588 | 1          | ANSCHLAG           | STOP            | BUTEE              | TOPE               |                           |     |
| 38       | 110 2657 | 2          | SECHSKANTMUTTER    | HEX-NUT         | ECROU 6 PANS       | TUERCA HEXAGONAL   | M10 DIN 934-M 8 A4C       |     |
| 41       | 111 8225 | 5          | SCHMIERNIPPPEL     | LUBE FITTING    | RACCORD GRAISSEUR  | NIPLE LUBRICACION  | SA 6H 3360                |     |
| 57       | 233 2748 | 1          | HEBEL              | LEVER/ARM       | LEVIER             | PALANCA            |                           |     |
| 59       | 233 0166 | 1          | SCHEIBE            | DISC/PANE/PLATE | RONDELLE/DISQUE    | DISCO              |                           |     |
| 60       | 233 0180 | 1          | KULISSE            | GUIDE SLOT/GATE | COULISSE/GRILLE    | PLACA GUIA         |                           |     |
| 61       | 111 2305 | 1          | SECHSKANTSCHRAUBE  | HEX-BOLT        | VIS 6 PANS         | TORNILLO HEXAGONAL | M 8 X 15 DIN 933- 8-8-A4C |     |
| 62       | 111 2326 | 1          | SECHSKANTSCHRAUBE  | HEX-BOLT        | VIS 6 PANS         | TORNILLO HEXAGONAL | M 8 X 22 DIN 933- 8-8-A4C |     |
| 63       | 110 8064 | 1          | SECHSKANTMUTTER    | HEX-NUT         | ECROU 6 PANS       | TUERCA HEXAGONAL   | M 8 DIN 555 VZKC          |     |
| 64       | 337 0451 | 1          | SCHEIBE            | DISC/PANE/PLATE | RONDELLE/DISQUE    | DISCO              | 1171-49-01-55             |     |
| 65       | 110 7163 | 2          | SCHEIBE            | DISC/PANE/PLATE | RONDELLE/DISQUE    | DISCO              | 9,5 DIN 126-A4C           |     |
| 66       | 111 2412 | 2          | SECHSKANTSCHRAUBE  | HEX-BOLT        | VIS 6 PANS         | TORNILLO HEXAGONAL | M10X 22 DIN 933- 8-8-A4C  |     |
| 67       | 111 2466 | 1          | SECHSKANTSCHRAUBE  | HEX-BOLT        | VIS 6 PANS         | TORNILLO HEXAGONAL | M10X 65 DIN 933- 8-8-A4C  |     |
| 68       | 233 0268 | 1          | GUMMIPUFFER        | RUBBER PAD      | TAMPON CAOUTCHOUC  | TOPE CAUCHO        |                           | 01  |
| 69       | 111 5961 | 2          | SPANNHUELSE        | DOWEL SLEEVE    | DOUILLE SERRAGE    | CASQUILLO FIADOR   | 6 X 50 DIN 1461           |     |
| 74       | 237 0832 | 1          | ZUGSTANGE          | PULLROD         | TIRANT             | BARRA TRACCION     |                           |     |
| 75       | 237 0833 | 1          | ZUGSTANGE          | PULLROD         | TIRANT             | BARRA TRACCION     |                           |     |
| 76       | 237 0872 | 1          | KUPPLUNGSPEDAL     | CLUTCH PEDAL    | PEDALE D EMBRAY    | PEDAL EMBRAGUE     |                           |     |
| 77       | 237 6248 | 1          | KUPPLUNGHEBEL      | CLUTCH LEVER    | LEVIER D EMBRAYAGE | PALANCA EMBRAGUE   |                           |     |
| 80       | 238 1451 | 1          | KUPPLUNGSWELLE     | SHAFT           | ARBRE D EMBRAYAGE  | EJE EMBRAGUE       |                           |     |

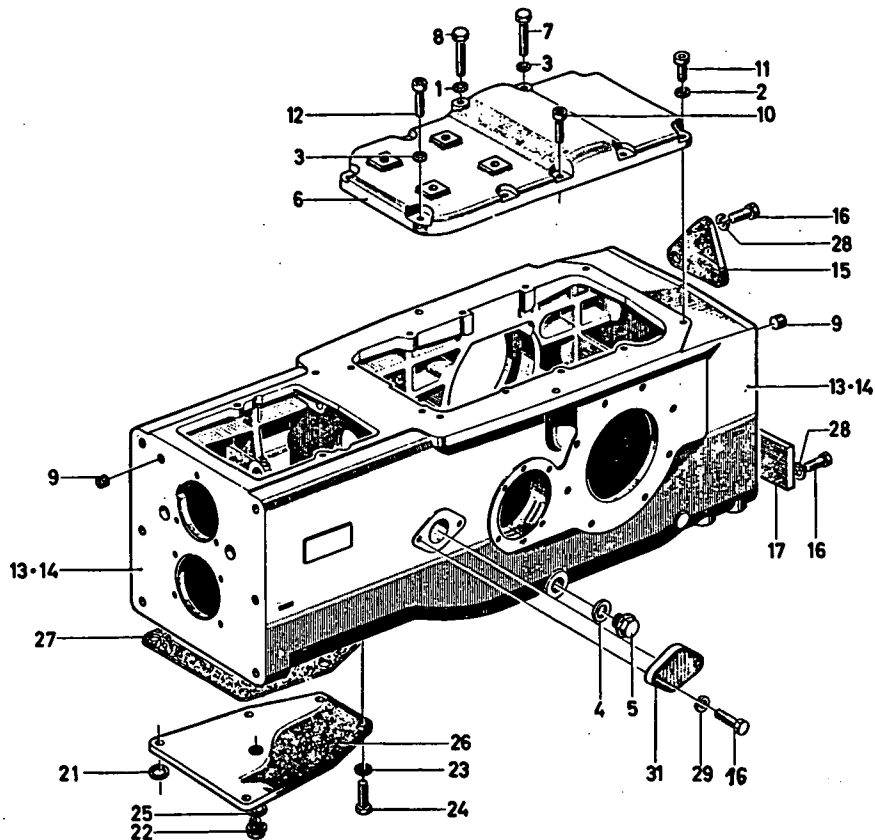

1445-08 500 4182

| Bld Nr. | Teile-Nr. | Stück-Zahl | Deutsch            | English           | Français           | Español            | Nummer/Bemerkung           | ETK |
|---------|-----------|------------|--------------------|-------------------|--------------------|--------------------|----------------------------|-----|
| 1       | 116 9694  | 6          | SICHERUNGSSCHEIBE  | LOCKING WASHER    | RONDELLE SECURITE  | ARANDELA SEGURIDAD | 10 H 2203                  |     |
| 2       | 116 9696  | 2          | SICHERUNGSSCHEIBE  | LOCKING WASHER    | RONDELLE SECURITE  | ARANDELA SEGURIDAD | 14 H 2203                  |     |
| 3       | 116 9695  | 2          | SICHERUNGSSCHEIBE  | LOCKING WASHER    | RONDELLE SECURITE  | ARANDELA SEGURIDAD | 12 H 2203                  |     |
| 4       | 111 8737  | 1          | DICHRING           | WASHER            | BAGUE D ETANCHEITE | ANILLO DE JUNTA    | A 22 X 27 DIN 7603-CU      |     |
| 5       | 111 8979  | 1          | VERSCHLUSSSCHRAUBE | SCREW PLUG        | BOUCHON FILETE     | TAPON ROSCADO      | AM22X1,5 DIN 7604          |     |
| 6       | 232 9637  | 1          | GEHÄUSEDECKEL      | HOUSING COVER     | COUV DE CARTER     | TAPA CAJA          |                            |     |
| 7       | 111 2451  | 2          | SECHSKANTSCHRAUBE  | HEX-BOLT          | VIS 6 PANS         | TORNILLO HEXAGONAL | M10X 45 DIN 933- 2.8-A4C   |     |
| 8       | 111 2461  | 2          | SECHSKANTSCHRAUBE  | HEX-BOLT          | VIS 6 PANS         | TORNILLO HEXAGONAL | M10X 55 DIN 933- 2.8-A4C   |     |
| 9       | 116 7325  | 1          | VERSCHLUSSSTOFFEN  | NIPPLE            | BOUCHON            | TAPON OBTURADOR    | A21 H 2873                 |     |
| 10      | 112 2361  | 2          | ZYLINDERSCHRAUBE   | CHEESE-HEAD SCREW | VIS TETE CYLINDR.  | TORN-CBZA-CILIND.  | M10X 35DIN 932- 8.8 A4C    |     |
| 11      | 111 0805  | 2          | ZYLINDERSCHRAUBE   | CHEESE-HEAD SCREW | VIS TETE CYLINDR.  | TORN-CBZA-CILIND.  | M14X 30DIN 932- 6.8 PHOSPH |     |
| 12      | 111 0756  | 2          | ZYLINDERSCHRAUBE   | CHEESE-HEAD SCREW | VIS TETE CYLINDR.  | TORN-CBZA-CILIND.  | M12X 30DIN 932- 6.8        |     |
| 13      | 339 2391  | 1          | GETRIEBEGEHÄUSE    | TRANSMISSION CASE | CARTER DE BOITE V  | CAJA ENGRANAJE     | 1445-08-01-13              |     |
| 14      | 232 5416  | 1          | GETRIEBEGEHÄUSE    | TRANSMISSION CASE | CARTER DE BOITE V  | CAJA ENGRANAJE     | 8009, ALLRADAUSFUEHRUNG    |     |
| 15      | 230 7582  | 1          | DECKEL             | COVER             | COUVERCLE          | TAPA               |                            |     |
| 16      | 111 2305  | 9          | SECHSKANTSCHRAUBE  | HEX-BOLT          | VIS 6 PANS         | TORNILLO HEXAGONAL | M 8 X 15 DIN 933- 2.8-A4C  |     |
| 17      | 232 1504  | 1          | DECKEL             | COVER             | COUVERCLE          | TAPA               |                            |     |
| 21      | 111 8737  | 1          | DICHRING           | WASHER            | BAGUE D ETANCHEITE | ANILLO DE JUNTA    | A 22 X 27 DIN 7603-CU      |     |
| 22      | 111 8979  | 1          | VERSCHLUSSSCHRAUBE | SCREW PLUG        | BOUCHON FILETE     | TAPON ROSCADO      | AM22X1,5 DIN 7604          |     |
| 23      | 116 9695  | 4          | SICHERUNGSSCHEIBE  | LOCKING WASHER    | RONDELLE SECURITE  | ARANDELA SEGURIDAD | 12 H 2203                  |     |
| 24      | 111 2500  | 6          | SECHSKANTSCHRAUBE  | HEX-BOLT          | VIS 6 PANS         | TORNILLO HEXAGONAL | M12X 20 DIN 933-M 2-A      |     |
| 25      | 111 8681  | 2          | DICHRING           | WASHER            | BAGUE D ETANCHEITE | ANILLO DE JUNTA    | A 12 X 18 DIN 7603-CU      |     |
| 26      | 232 5797  | 1          | DECKEL             | COVER             | COUVERCLE          | TAPA               |                            |     |
| 27      | 232 5798  | 1          | DICHTUNG           | GASKET            | GARNITURE/JOINT    | JUNTA              |                            |     |
| 28      | 110 2799  | 7          | FEDERRING          | SPRING LOCKWASHER | RONDELLE GROUER    | ARANDELA ELASTICA  | A 8 DIN 128 A4C            |     |
| 29      | 110 2799  | 2          | FEDERRING          | SPRING LOCKWASHER | RONDELLE GROUER    | ARANDELA ELASTICA  | A 8 DIN 128 A4C            |     |
| 31      | 230 7702  | 1          | DECKEL             | COVER             | COUVERCLE          | TAPA               |                            |     |





GETRIEBEGEHÄUSE  
TRANSMISSION CASE  
CARTER DE TRANSMISSION  
CAJA DEL TREN DE ENGRANAJES

7876/6679  
1445-08 502 0203

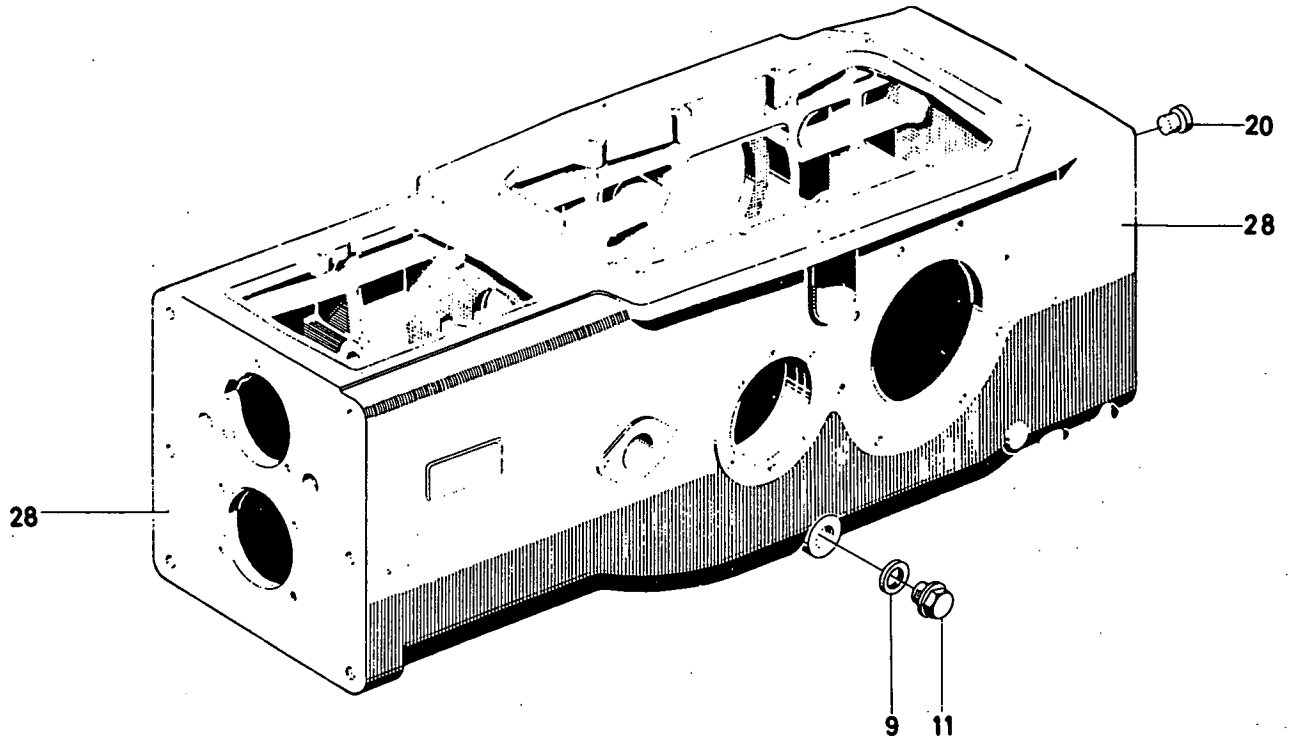

| Bild<br>Nr. | Teile-Nr. | Stück-<br>Zahl |                    |                   |                    |                 | 1445-08 502 0203    |     |
|-------------|-----------|----------------|--------------------|-------------------|--------------------|-----------------|---------------------|-----|
|             |           |                | Deutsch            | English           | Français           | Español         | Nummer/Bemerkung    | ETK |
| 9           | 111 8737  | 1              | DICHTRING          | WASHER            | BAGUE D ETANCHEITE | ANILLO DE JUNTA | A 22X27 DIN 7603 CU |     |
| 11          | 111 8771  | 1              | VERSCHLUSSSCHRAUBE | SCREW PLUG        | BOUCHON FILETE     | TAPON ROSCADO   | AN 22X1,5 DIN7604   |     |
| 20          | 111 7325  | 1              | VERSCHLUSSSTOPFEN  | NIPPLE            | BOUCHON            | TAPON OBTURADOR | A 21 H 2873         |     |
| 28          | 237 8710  | 1              | GETRIEBEGEHÄUSE    | TRANSMISSION CASE | CARTER DE BOITE V  | CAJA ENGRANAJE  |                     |     |



**GETRIEBEGEHÄUSE - ALLRAD**  
**TRANSMISSION CASE - FOUR WHEEL DRIVE**  
**CARTER DE TRANSMISSION-TOUTES ROUES MOTRICES**  
**CAJA DE LA TRANSMISION-TRACCION EN LAS 4 RUEDAS**

7868/0403  
 1445-08 502 0204

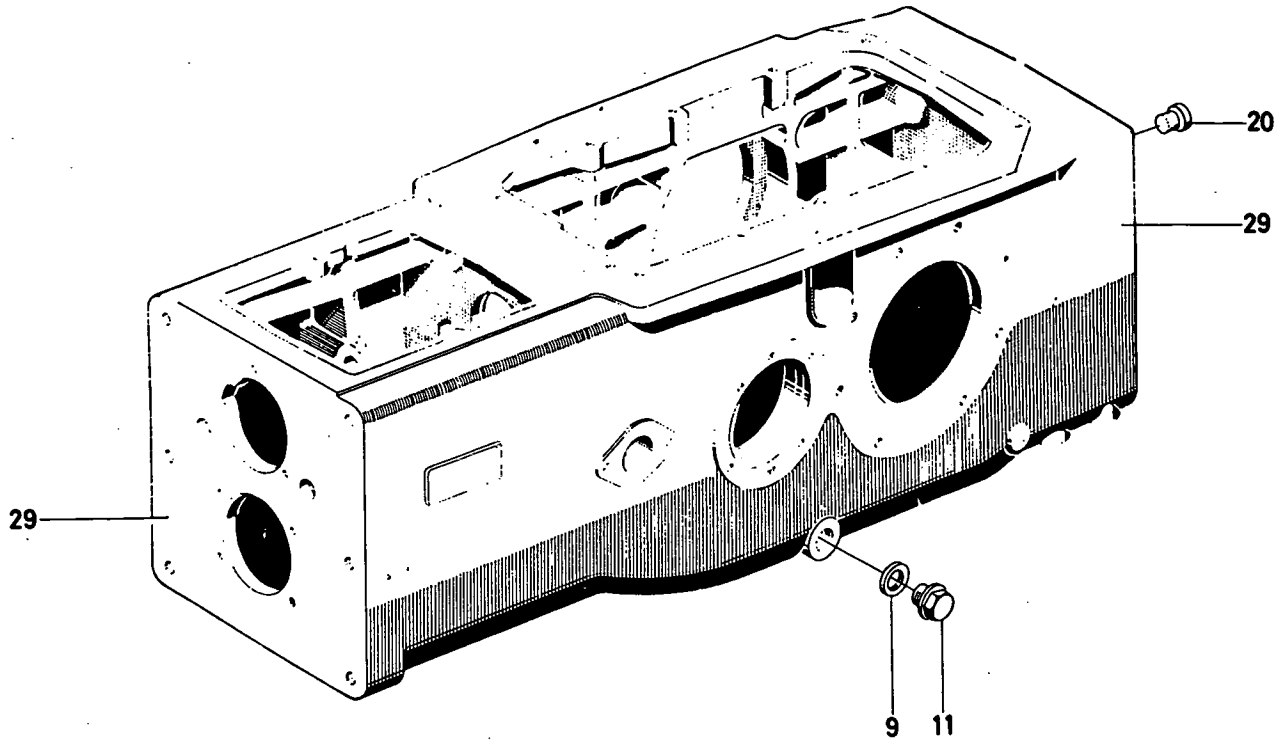

| Bild<br>Nr. | Teil-Nr. | Stück-<br>Zahl | Deutsch            | English           | Français           | Español         | 1445-08 502 0204    |  | ETK |
|-------------|----------|----------------|--------------------|-------------------|--------------------|-----------------|---------------------|--|-----|
|             |          |                |                    |                   |                    |                 | Nummer / Bemerkung  |  |     |
| 9           | 111 8737 | 1              | DICHTRING          | WASHER            | BAGUE D ETANCHEITE | ANILLO DE JUNTA | A 22x27 DIN 7603 CU |  |     |
| 11          | 111 8979 | 1              | VERSCHLUSSSCHRAUBE | SCREW PLUG        | BOUCHON FILETE     | TAPON ROSCADO   | AN 22x1,5 DIN7604   |  |     |
| 20          | 116 7325 | 1              | VERSCHLUSSSTOPFEN  | NIPPLE            | BOUCHON            | TAPON OBTURADOR | A 21 H 2873         |  |     |
| 29          | 237 8913 | 1              | GETRIEBEGEHÄUSE    | TRANSMISSION CASE | CARTER DE BOITE V  | CAJA ENGRANAJE  |                     |  |     |

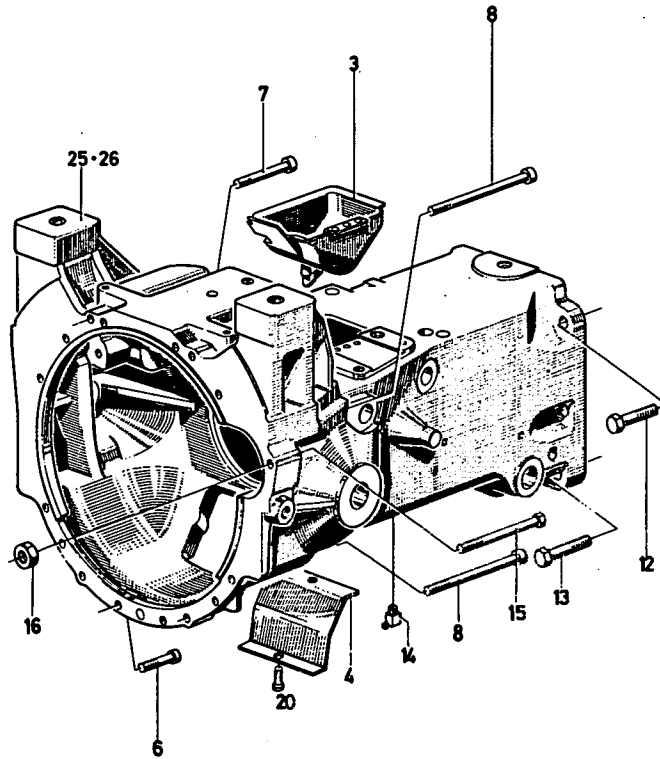

| Bild Nr. | Teile-Nr. | Stück-Zahl | Deutsch           | English           | Français           | Español            | Nummer/Bemerkung              | ETK |
|----------|-----------|------------|-------------------|-------------------|--------------------|--------------------|-------------------------------|-----|
| 3        | 230 8112  | 1          | HAUBE             | HOOD              | CAPOT/BOUNNET      | CAPERUZA/CAPOT     |                               |     |
| 4        | 338 9276  | 1          | HANDLOCHBECKEL    | HAND HOLE COVER   | COUVERCLE VISITE   | TAPA ORIF-ACCESO   | 1145-09-01-02                 |     |
| 6        | 112 2363  | 4          | ZYLINDERSCHRAUBE  | CHEESE-HEAD SCREW | VIS TETE CYLINDR.  | TORN-CEZA-CILIND.  | M10X 70DIN 912- 8-8 A4C       |     |
| 7        | 111 0712  | 4          | ZYLINDERSCHRAUBE  | CHEESE-HEAD SCREW | VIS TETE CYLINDR.  | TORN-CEZA-CILIND.  | M10X 90DIN 912- 8-8 A4C       |     |
| 8        | 111 0734  | 3          | ZYLINDERSCHRAUBE  | CHEESE-HEAD SCREW | VIS TETE CYLINDR.  | TORN-CEZA-CILIND.  | M10X 160DIN 912- 8-8-A4C      |     |
| 12       | 110 1145  | 4          | SECHSKANTSCHRAUBE | HEX-BOLT          | VIS 6 PANS         | TORNILLO HEXAGONAL | M16X2 X 50 DIN 961-M 8-8 A4C  |     |
| 13       | 112 3784  | 2          | SECHSKANTSCHRAUBE | HEX-BOLT          | VIS 6 PANS         | TORNILLO HEXAGONAL | M16X2 X 60 DIN 960-M 8-8 VZKC |     |
| 14       | 116 8227  | 1          | KEGELSCHIERNIPPEL | LUBE FITTING      | GRAISSEUR CONIQUE  | ENGRASADOR CONICO  | SB 8H 3360                    |     |
| 15       | 111 2476  | 1          | SECHSKANTSCHRAUBE | HEX-BOLT          | VIS 6 PANS         | TORNILLO HEXAGONAL | M10X 90 DIN 933- 8-8-A4C      |     |
| 16       | 111 2841  | 1          | SECHSKANTMUTTER   | HEX-NUT           | ECROU 6 PANS       | TUERCA HEXAGONAL   | M16X 25 DIN 933-M10-9         |     |
| 20       | 111 2232  | 2          | SECHSKANTSCHRAUBE | HEX-BOLT          | VIS 6 PANS         | TORNILLO HEXAGONAL | M 6X 10 DIN 933- 8-8-A4C      |     |
| 25       | 237 7874  | 1          | KUPPLUNGSGEHAEUSE | CLUTCH HOUSING    | CARTER D EMBRAYAGE | CAJA EMBRAGUE      | 8027 BIS FAHRGESTELL-NO       |     |
| 26       | 238 6000  | 1          | KUPPLUNGSGEHAEUSE | CLUTCH HOUSING    | CARTER D EMBRAYAGE | CAJA EMBRAGUE      | 8003-AB FAHRGESTELL-NO        |     |



WECHSELGETRIEBE  
CHANGE-SPEED GEARBOX  
BOITE DE VITESSES  
CAMBIO DE MARCHAS

1435-11 500 4184

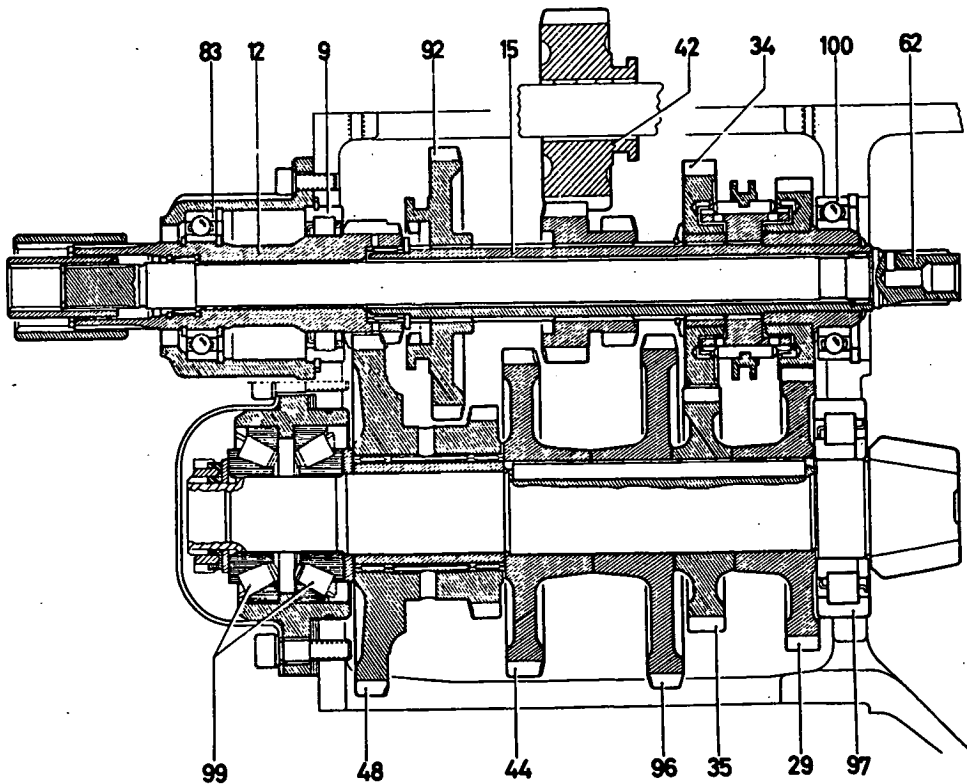
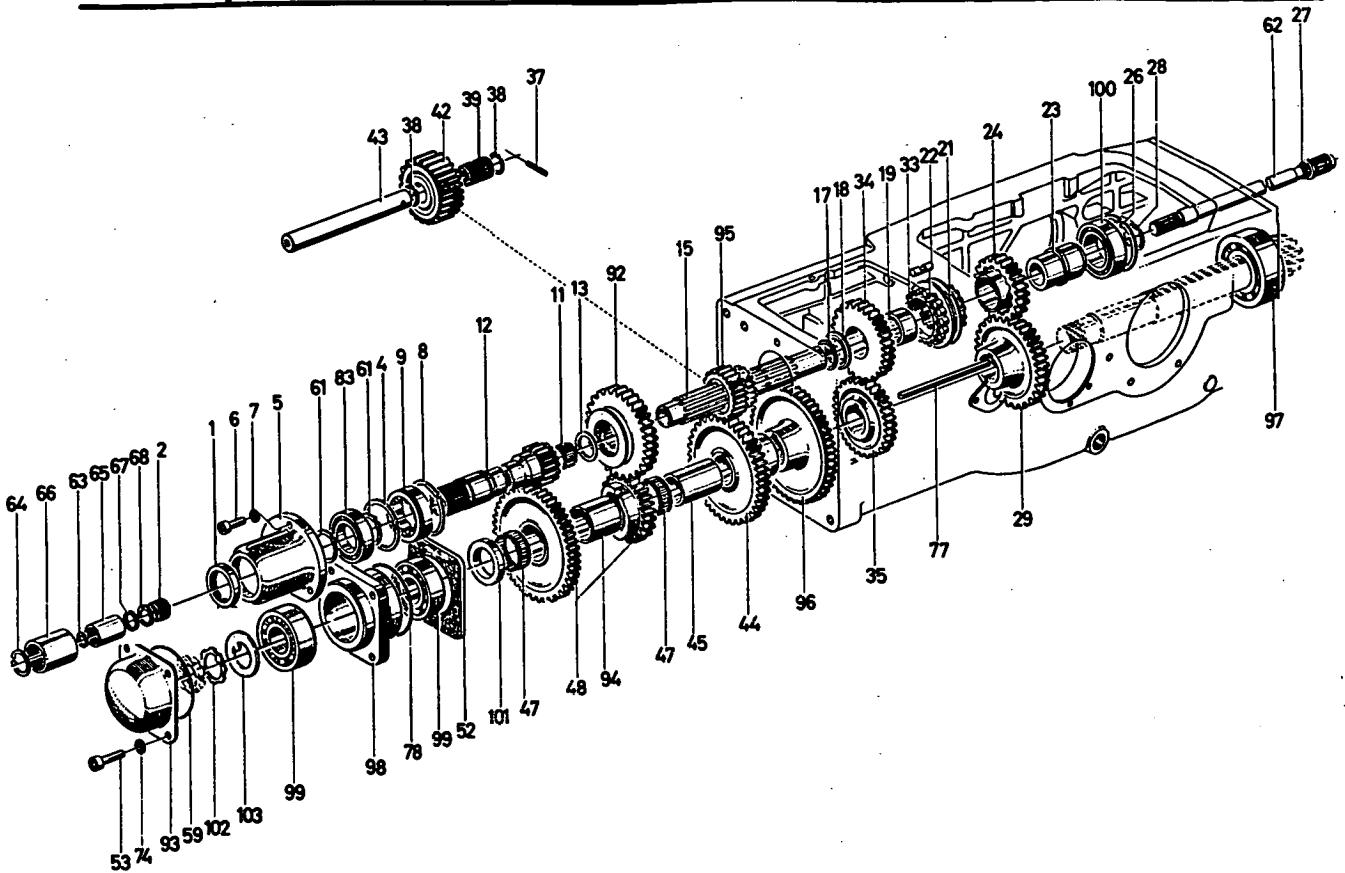

| Bld Nr. | Tele-Nr. | Stück-Zahl | Deutsch           | English           | Français           | Español            | Nummer/Bemerkung  | ETK |
|---------|----------|------------|-------------------|-------------------|--------------------|--------------------|---|-----|
| 1       | 116 0851 | 1          | WELLENDICHRING    | SHAFT SEAL        | JOINT D ARBRE      | ANILLO HERMET-EJE  | R 40X 55X 8H 2939                                       | 01  |
| 2       | 116 8792 | 1          | NADELKAEFIG       | NEEDLE GAGE       | CAGE A AIGUILLES   | JAULA AGUJAS       | U 22 X 26X13 H 4455                                     | 01  |
| 4       | 110 7846 | 1          | SICHERUNGSRING    | CIRCLIP           | CIRCLIP            | CIRCLIP            | 68X2,5 DIN 472  |     |
| 5       | 339 2237 | 1          | LAGERDECKEL       | BEARING CAP       | CHAPEAU DE PALIER  | TAPA SOPORTE       | 1434-11-01-72   |     |
| 6       | 111 0560 | 3          | ZYLINDERSCHRAUBE  | CHEESE-HEAD SCREW | VIS TETE CYLINDR.  | TORN-CBZA-CILIND.  | M 8X 20DIN 932-10.9                                     |     |
| 7       | 116 9689 | 3          | SICHERUNGSSCHEIBE | LOCKING WASHER    | RONDELLE SECURITE  | ARANDELA SEGURIDAD | 8 H 2203  |     |
| 8       | 111 7455 | 1          | SPRENGRING        | SNAP RING         | AGRAFE CIRCULAIRE  | ANILLO RETENCION   | SP 72DIN 5417   |     |
| 9       | 111 7371 | 1          | ROLLENLAGER       | ROLLER BEARING    | ROUL A ROULEAUX    | COJINETE RODILLOS  | RNU 207N DIN 5412                                       | 01  |
| 11      | 116 8738 | 1          | NADELKAEFIG       | NEEDLE GAGE       | CAGE A AIGUILLES   | JAULA AGUJAS       | MS 30 X 35X17 H 4455                                    | 01  |
| 12      | 339 2192 | 1          | ANTRIEESWELLE     | DRIVE SHAFT       | ARBRE DE COMMANDE  | EJE MOTRIZ         | 1434-11-01-04   |     |
| 13      | 339 2207 | 1          | ABSTANDBSCHEIBE   | SPACER WASHER     | RONDELLE ECARTEN   | ARANDELA DISTANC.  | 1434-11-01-16   |     |
| 15      | 339 2256 | 1          | HOHLWELLE         | QUILL SHAFT       | ARBRE CREUX        | EJE HUECO          | 1434-11-03-07   |     |
| 17      | 116 7218 | 1          | SPRENGRING        | SNAP RING         | AGRAFE CIRCULAIRE  | ANILLO RETENCION   | 35X1,5H 2258  |     |
| 18      | 339 2201 | 1          | ABSTANDBSCHEIBE   | SPACER WASHER     | RONDELLE ECARTEN   | ARANDELA DISTANC.  | 1434-11-01-09   |     |
| 19      | 339 2202 | 1          | LAGERBUCHSE       | BEARING BUSH      | DOUILLE PALIER     | CASQUILLO SOPORTE  | 1434-11-01-11   |     |
| 21      | 339 2206 | 1          | SCHIEBENUFFE      | SLIDING SLEEVE    | MANCHON BALADEUR   | MANGUITO CORREDIZO | 1434-11-01-14   |     |
| 22      | 339 2239 | 20         | BOLZEN            | PIN/BOLT/STUD     | BOULON/AXE         | BULON              | 1434-11-01-75   |     |
| 23      | 339 2257 | 1          | BUCHSE            | BUSH              | DOUILLE            | CASQUILLO          | 1434-11-03-15   |     |
| 24      | 339 2258 | 1          | SCHALTRAD         | GEAR/WHEEL        | ROUE COMMANDE      | RUEDA CAMBIO/MANDO | 1434-11-03-17<br>Z 28                                   |     |
| 26      | 116 0062 | 1          | SICHERUNGSRING    | CIRCLIP           | CIRCLIP            | CIRCLIP            | 75X4 H 2274   |     |
| 27      | 116 8791 | 1          | NADELKAEFIG       | NEEDLE GAGE       | CAGE A AIGUILLES   | JAULA AGUJAS       | T 20 X 24X10 H 4455                                     | 01  |
| 28      | 116 5851 | 1          | SICHERUNGSRING    | CIRCLIP           | CIRCLIP            | CIRCLIP            | LA 32H 712  |     |
| 29      | 339 2213 | 1          | ZAHNRAD           | GEAR              | ROUE DENTEE        | RUEDA DENTADA      | Z 41  |     |
| 33      | 339 2246 | 1          | BOLZENFUHRUNG     | PIN GUIDE         | GUIDE-BOULON/AXE   | GUIA PERNOS        | 1434-11-01-83   |     |
| 34      | 339 2245 | 1          | ZAHNRAD           | GEAR              | ROUE DENTEE        | RUEDA DENTADA      | 1434-11-01-82   |     |
| 35      | 339 2243 | 1          | ZAHNRAD           | GEAR              | ROUE DENTEE        | RUEDA DENTADA      | Z 35  |     |
| 37      | 111 5459 | 1          | SPANNHUELSE       | DOWEL SLEEVE      | DOUILLE SERRAGE    | CASQUILLO FIADOR   | 6 X 45DIN 1481  |     |
| 38      | 116 7223 | 2          | SPRENGRING        | SNAP RING         | AGRAFE CIRCULAIRE  | ANILLO RETENCION   | 28X1,2 H 2259   |     |
| 39      | 116 1601 | 1          | NADELKAEFIG       | NEEDLE GAGE       | CAGE A AIGUILLES   | JAULA AGUJAS       | 2K 24 X 28X16 H 4455                                    | 01  |
| 42      | 339 2219 | 1          | RUECKLAUFRAD      | REVERSE GEAR      | ROUE DE MARCHE AR  | RUEDA MARCHA ATRAS | Z 28  |     |
| 43      | 339 1856 | 1          | RUECKLAUFWELLE    | RETURN SHAFT      | ARBRE DE MARCHE AR | EJE MARCHA ATRAS   | 1424-11-01-23   |     |
| 44      | 339 2221 | 1          | ZAHNRAD           | GEAR              | ROUE DENTEE        | RUEDA DENTADA      | 1434-11-01-36<br>Z 47                                   |     |
| 45      | 339 2223 | 1          | BUCHSE            | BUSH              | DOUILLE            | CASQUILLO          | 1434-11-01-37   |     |
| 47      | 116 8794 | 2          | NADELKAEFIG       | NEEDLE GAGE       | CAGE A AIGUILLES   | JAULA AGUJAS       | MS 47 X 52X17 H 4455                                    | 01  |
| 48      | 339 2225 | 1          | DOPPELZAHNRAD     | DUPLEX GEAR       | ROUE DENTEE JUNELE | RDA-DENTADA DOBLE  | 1434-11-01-41<br>Z 52/29                                |     |
| 52      | 339 1880 | SZ         | BEILAGE           | SHIM              | CALE               | SUPLEMENTO         | 1424-11-02-10<br>8076-EINZELTEILE SIEME POS.<br>950-954 |     |
| 53      | 111 0665 | 4          | ZYLINDERSCHRAUBE  | CHEESE-HEAD SCREW | VIS TETE CYLINDR.  | TORN-CBZA-CILIND.  | M10X 35DIN 932-10.9                                     |     |
| 59      | 116 6126 | 1          | RUNDGUMRING       | O-SEAL            | ANNEAU TORIQUE     | ANILLO GOMA REDOND | 95 X 3 H 721  | 01  |
| 61      | 110 7755 | 2          | SICHERUNGSRING    | CIRCLIP           | CIRCLIP            | CIRCLIP            | 40X1,75DIN 471  |     |
| 62      | 339 2233 | 1          | ANTRIEBSWELLE     | DRIVE SHAFT       | ARBRE DE COMMANDE  | EJE MOTRIZ         | 1434-11-01-62   |     |
| 63      | 110 7808 | 1          | SICHERUNGSRING    | CIRCLIP           | CIRCLIP            | CIRCLIP            | 19X1 DIN 472  |     |
| 64      | 116 7227 | 1          | SPRENGRING        | SNAP RING         | AGRAFE CIRCULAIRE  | ANILLO RETENCION   | C13X3H 2203   |     |
| 65      | 339 2235 | 1          | VERBINDUNGSSTUECK | CONNECTING PIECE  | RACCORD            | PIEZA UNION        | 1434-11-01-65   |     |
| 66      | 339 2236 | 1          | VERBINDUNGSSTUECK | CONNECTING PIECE  | RACCORD            | PIEZA UNION        | 1434-11-01-65   |     |
| 67      | 117 0600 | 1          | DICHRING          | WASHER            | BAGUE D ETANCHEITE | ANILLO DE JUNTA    | G 22X 28X 4H 2939                                       | 01  |
| 68      | 116 7222 | 1          | SPRENGRING        | SNAP RING         | AGRAFE CIRCULAIRE  | ANILLO RETENCION   | 26X1,2 H 2259   |     |
| 74      | 116 9699 | 4          | SICHERUNGSSCHEIBE | LOCKING WASHER    | RONDELLE SECURITE  | ARANDELA SEGURIDAD | 10 H 2203   |     |
| 77      | 121 6189 | 1          | PASSFEDER         | KEY               | CLAVETTE ENCASTREE | LENGUETA AJUSTE    | 2 525 A 5   |     |

| Blz<br>Nr. | Teile-Nr. | Stück-<br>Zahl | Deutsch          | English            | Français           | Español            | Nummer/Bemerkung            | ETK |
|------------|-----------|----------------|------------------|--------------------|--------------------|--------------------|-----------------------------|-----|
| 78         | 116 6121  | 1              | RUNDGUMRING      | O-SEAL             | ANNEAU TORIQUE     | ANILLO GOMA REDOND | 90 X 2 H 721                | 01  |
| 83         | 112 2274  | 1              | RILLENKUGELLAGER | BALL BEARING       | ROUL RAINURE BILLE | COJ.BOLAS FIJO     | 6008-22 DIN 625             | 01  |
| 92         | 339 2351  | 1              | SCHALTRAD        | GEAR/WHEEL         | ROUE COMMANDE      | RUEDA CAMBIO/MANDO | 1435-11-01-92<br>Z 39       |     |
| 93         | 339 2443  | 1              | BECKEL           | COVER              | COUVERCLE          | TAPA               | 1445-11-01-49               |     |
| 94         | 339 2224  | 1              | ABSTANDROHR      | SPACER TUBE        | TUBE ECARTEMENT    | TUBO DISTANCIARIO  | 1434-11-01-38               |     |
| 95         | 230 9697  | 1              | SCHALTRAD        | GEAR/WHEEL         | ROUE COMMANDE      | RUEDA CAMBIO/MANDO | Z 21/17                     |     |
| 96         | 230 9698  | 1              | ZAHNRAB          | GEAR               | ROUE DENTEE        | RUEDA DENTADA      | Z 51                        |     |
| 97         | 339 2425  | 1              | ROLLENLAGER      | ROLLER BEARING     | ROUL A ROULEAUX    | COJINETE RODILLOS  | 1445-11-01-23               | 01  |
| 98         | 339 2440  | 1              | LAGERFLANSCH     | BEARING FLANGE     | BRIDE SUPPORT      | BRIDA SOPORTE      | 1445-11-01-44               |     |
| 99         | 110 9990  | 2              | KEGELROLLENLAGER | TAP-ROLLER BEARING | ROULEM A ROUL CON  | COJ.RODIL.COMICOS  | 3307 DIN 720                | 01  |
| 100        | 112 2857  | 1              | ZYL.-ROLLENLAGER | PAR-ROLL-BEARING   | ROULEM.ROUL.CYL.   | COJ.RODILL.CILINDR | NJ 1009 ZS DIN 5412         | 01  |
| 101        | 232 9654  | 1              | ABSTANDRING      | SPACER RING        | BAGUE ECARTEMENT   | ARO DISTANCIARIO   | 1135-11-02-49               |     |
| 102        | 121 6057  | 1              | SICHERUNGSRING   | CIRCLIP            | CIRCLIP            | CIRCLIP            | Z 251 B 35                  |     |
| 103        | 339 2442  | 1              | SCHREIBE         | DISC/PANE/PLATE    | RONDELLE/DISQUE    | DISCO              | 1445-11-01-46               |     |
| 950        | 339 1875  | NB             | BEILAGE          | SHIM               | CALE               | SUPLEMENTO         | 1424-11-02-01<br>A 0.5 MM.  |     |
| 951        | 339 1876  | NB             | BEILAGE          | SHIM               | CALE               | SUPLEMENTO         | 1424-11-02-02<br>A 0.63 MM. |     |
| 952        | 339 1877  | NB             | BEILAGE          | SHIM               | CALE               | SUPLEMENTO         | 1424-11-02-03<br>A 0.75 MM  |     |
| 953        | 339 1878  | NB             | BEILAGE          | SHIM               | CALE               | SUPLEMENTO         | 1424-11-02-04<br>A 0.88 MM  |     |
| 954        | 339 1879  | NB             | BEILAGE          | SHIM               | CALE               | SUPLEMENTO         | 1424-11-02-05<br>A 1.0 MM.  |     |

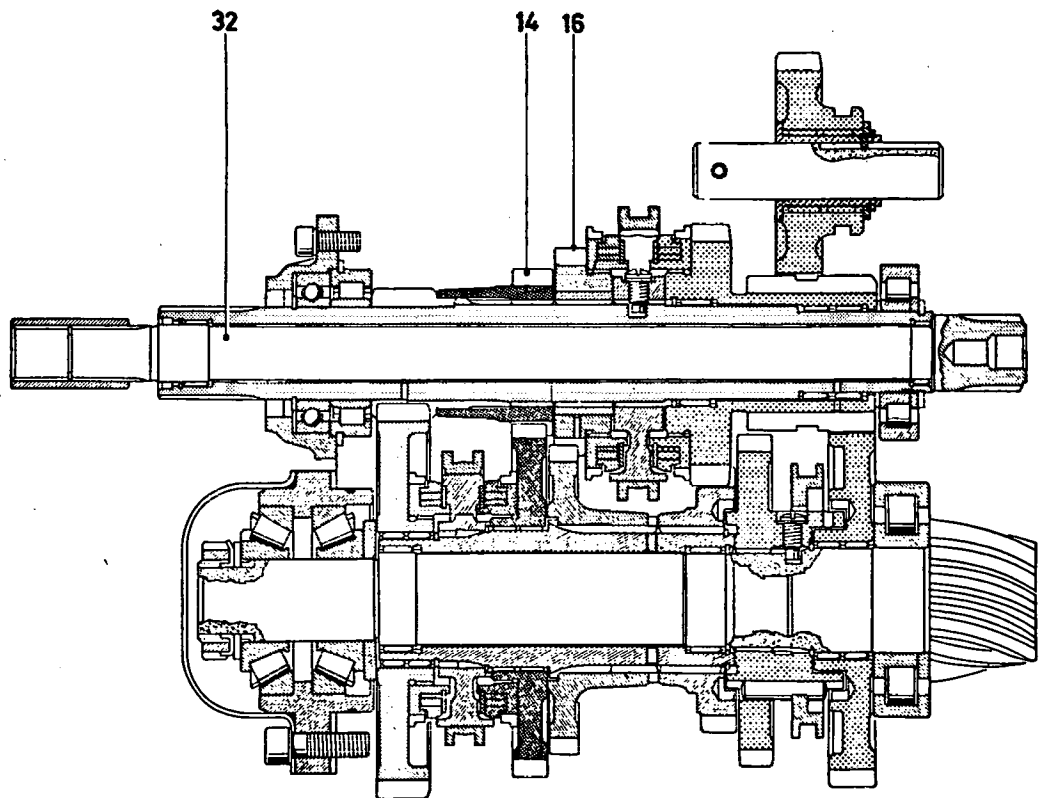
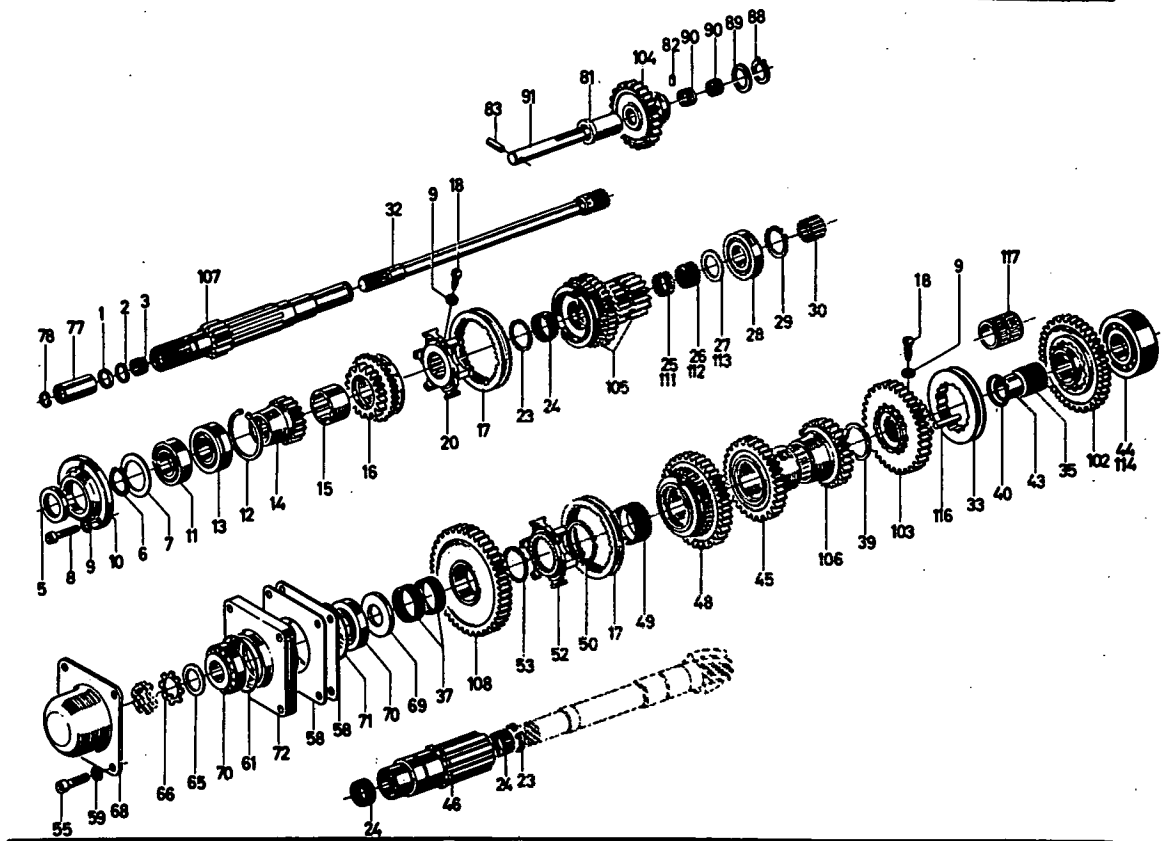

| Bld Nr. | Teil-Nr. | Stück-Zahl | Deutsch            | English           | Français           | Español             | Nummer/Bemerkung  | ETK |
|---------|----------|------------|--------------------|-------------------|--------------------|---------------------|---|-----|
| 1       | 116 0346 | 1          | DICHTRING          | WASHER            | BAGUE D ETANCHEITE | ANILLO DE JUNTA     | 6 24X 30X 4H 2939   | 01  |
| 2       | 116 7223 | 1          | SPRENGRING         | SNAP RING         | AGRAFE CIRCULAIRE  | ANILLO RETENCION    | 28X1,2 H 2259   |     |
| 3       | 116 8762 | 1          | NADELKAEFIG        | NEEDLE GAGE       | CAGE A AIGUILLES   | JAULA AGUJAS        | K 24 X 28X13 H 4455   | 01  |
| 5       | 116 1002 | 1          | WELLENDICHTRING    | SHAFT SEAL        | JOINT D ARBRE      | ANILLO HERMET-EJE   | R 40R 55 X 8 H 2940-SI  | 01  |
| 6       | 110 7755 | 1          | SICHERUNGSRING     | CIRCLIP           | CIRCLIP            | CIRCLIP             | 40X1,75DIN 471  |     |
| 7       | 230 2055 | SZ         | BEILAGE            | SHIM              | CALE               | SUPLEMENTO          | 8076, EINZELTEILE SIEHE POS. 950-957  |     |
| 8       | 112 6718 | 3          | ZYLINDERSCHRAUBE   | CHEESE-HEAD SCREW | VIS TETE CYLINDR.  | TORN-CBZA-CILINDR.  | M AX 20DIN 932- 8-8 44C   |     |
| 9       | 116 9689 | 5          | SICHERUNGSSCHREIBE | LOCKING WASHER    | RONDILLE SECURITE  | ARANDELA SEGURIDAD  | 8 H-2203  |     |
| 10      | 230 1889 | 1          | LAGERDECKEL        | BEARING CAP       | CHAPEAU DE PALIER  | TAPA SOPORTE        |   |     |
| 11      | 110 1409 | 1          | KILLENKUGELLAGER   | BALL BEARING      | ROUL RAINURE BILLE | COJ-BOLAS FIJO      | 6008 33DIN 625  | 01  |
| 12      | 111 7455 | 1          | SPRENGRING         | SNAP RING         | AGRAFE CIRCULAIRE  | ANILLO RETENCION    | SP 720IN 5917   |     |
| 13      | 230 1876 | 1          | ZYL.-ROLLENLAGER   | PAR-ROLL-BEARING  | ROULEM-ROUL-CYL.   | COJ-RODILL-CILINDR. |   | 01  |
| 14      | 230 2386 | 1          | ZAHNRAD            | GEAR              | ROUE DENTEE        | RUEDA DENTADA       | Z 18  |     |
| 15      | 230 1875 | 1          | BUCHSE             | BUSH              | BOUILLE            | CASQUILLO           |   |     |
| 16      | 230 3570 | 1          | ZAHNRAD            | GEAR              | ROUE DENTEE        | RUEDA DENTADA       | 3-6   |     |
| 17      | 230 2353 | 2          | SCHALTRUFFE        | SHIFT SLEEVE      | MANCHON COMMANDE   | MANGUITO CAMBIO     |   |     |
| 18      | 230 3566 | 2          | LINSENKNSCHRAUBE   | OVAL-HEAD SCREW   | VIS A BOIS NOYEE   | TORN-CAB-EMBUTID-   |   | 01  |
| 20      | 230 2351 | 1          | MUFFE              | SLEEVE            | MANCHON            | MANGUITO            |   |     |
| 23      | 116 0345 | 2          | SPRENGRING         | SNAP RING         | AGRAFE CIRCULAIRE  | ANILLO RETENCION    | 45X1,5 H 2259   |     |
| 24      | 116 8741 | 3          | NADELKAEFIG        | NEEDLE GAGE       | CAGE A AIGUILLES   | JAULA AGUJAS        | HS 40 X 45X17 H 4455  | 01  |
| 25      | 116 0078 | 1          | NADELKAEFIG        | NEEDLE GAGE       | CAGE A AIGUILLES   | JAULA AGUJAS        | K 35 X 40X13 H 4455<br>8027, BIS FAHRGESTELL-NO<br>8004, AB FAHRG-NO-POS-111        | 01  |
| 26      | 116 0064 | 1          | NADELKAEFIG        | NEEDLE GAGE       | CAGE A AIGUILLES   | JAULA AGUJAS        | HS 35 X 40X17 H 4455<br>8027, BIS FAHRGESTELL-NO<br>8004, AB FAHRG-NO-POS-112       | 01  |
| 27      | 230 2045 | SZ         | BEILAGE            | SHIM              | CALE               | SUPLEMENTO          | 8027, BIS FAHRGESTELL-NO<br>8076, EINZELT, SIEH-POS-958-964                         |     |
| 28      | 230 1897 | 1          | ZYL.-ROLLENLAGER   | PAR-ROLL-BEARING  | ROULEM-ROUL-CYL.   | COJ-RODILL-CILINDR  |   | 01  |
| 29      | 110 7749 | 1          | SICHERUNGSRING     | CIRCLIP           | CIRCLIP            | CIRCLIP             | 35X2,5 DIN 471  |     |
| 30      | 116 8761 | 1          | NADELKAEFIG        | NEEDLE GAGE       | CAGE A AIGUILLES   | JAULA AGUJAS        | K 24 X 28X13 H 4455   | 01  |
| 32      | 230 7268 | 1          | ANTRIEBSWELLE      | DRIVE SHAFT       | ARBRE DE COMMANDE  | EJE MOTRIZ          |   |     |
| 33      | 230 1891 | 1          | SCHALTRING         | SHIFT RING        | BAGUE COMMANDE     | ANILLO CAMBIO       |   |     |
| 35      | 116 3993 | 1          | NADELKAEFIG        | NEEDLE GAGE       | CAGE A AIGUILLES   | JAULA AGUJAS        | K 50 X 55X13,5 H 4455<br>8027, BIS FAHRGESTELL-NO<br>8233, NUR MIT POS-43 VERWENDEN | 01  |
| 37      | 116 0074 | 2          | NADELKAEFIG        | NEEDLE GAGE       | CAGE A AIGUILLES   | JAULA AGUJAS        | HS 58 X 57X12 H 4455  | 01  |
| 39      | 116 0083 | 1          | SPRENGRING         | SNAP RING         | AGRAFE CIRCULAIRE  | ANILLO RETENCION    | 55X1,5H 2258  |     |
| 40      | 116 2930 | 1          | SPRENGRING         | SNAP RING         | AGRAFE CIRCULAIRE  | ANILLO RETENCION    | 45X1,5H 2258  |     |
| 43      | 233 4006 | 1          | INNENRING          | INSIDE RING       | BAGUE INTERIEURE   | ANILLO INTERIOR     | 8027, BIS FAHRGESTELL-NO<br>8233, NUR MIT POS-35 VERWENDEN                          | 01  |
| 45      | 230 3440 | 1          | ZAHNRAD            | GEAR              | ROUE DENTEE        | RUEDA DENTADA       | Z 35  |     |
| 46      | 230 7777 | 1          | WOMLWELLE          | QUILL SHAFT       | ARBRE CREUX        | EJE MUECO           |   |     |
| 48      | 231 1507 | 1          | ZAHNRAD            | GEAR              | ROUE DENTEE        | RUEDA DENTADA       | 2-6   |     |
| 49      | 116 1602 | 1          | NADELKAEFIG        | NEEDLE GAGE       | CAGE A AIGUILLES   | JAULA AGUJAS        | 25 58 X 62X25 H 4455  | 01  |
| 50      | 116 0082 | 1          | SPRENGRING         | SNAP RING         | AGRAFE CIRCULAIRE  | ANILLO RETENCION    | 58X1,5H 2258  |     |
| 52      | 230 2352 | 1          | MUFFE              | SLEEVE            | MANCHON            | MANGUITO            | 1-U-2-6   |     |
| 53      | 116 0081 | 1          | SPRENGRING         | SNAP RING         | AGRAFE CIRCULAIRE  | ANILLO RETENCION    | 52X1,5H 2258  |     |
| 55      | 111 0645 | 4          | ZYLINDERSCHRAUBE   | CHEESE-HEAD SCREW | VIS TETE CYLINDR.  | TORN-CBZA-CILINDR.  | M10X 35DIN 932-10-9   |     |
| 58      | 339 1880 | SZ         | BEILAGE            | SHIM              | CALE               | SUPLEMENTO          | 1424-11-02-10<br>8076, EINZELTEILE SIEHE POS.<br>965-969                            |     |



| Bld. Nr. | Tele-Nr. | Stück-Zahl | Deutsch           | English            | Francais           | Español            | Nummer/Bemerkung  | ETK |
|----------|----------|------------|-------------------|--------------------|--------------------|--------------------|---|-----|
| 59       | 116 9694 | 4          | SICHERUNGSSCHEIBE | LOCKING WASHER     | RONDELLE SECURITE  | ARANDELA SEGURIDAD | 10 H 2203   |     |
| 61       | 116 6126 | 1          | RUNDGUMMRING      | O-SEAL             | ANNEAU TORIQUE     | ANILLO GOMA REDOND | 95 X 3 H 721  | 01  |
| 65       | 339 2442 | 1          | SCHLEIBE          | DISC/PANE/PLATE    | RONDELLE/DISQUE    | DISCO              | 1445-11-01-46   |     |
| 66       | 121 6057 | 1          | SICHERUNGSBLECH   | LOCKING PLATE      | TOLE DE SECURITE   | CHAPA SEGURIDAD    | 2 251 B 35  |     |
| 68       | 339 2443 | 1          | DECKEL            | COVER              | COUVERCLE          | TAPA               | 1445-11-01-49   |     |
| 69       | 230 7571 | 1          | ANLAUFSCHLEIBE    | STOP WASHER        | DISQUE BUTEE       | ARANDELA TOPE      |   |     |
| 70       | 110 9990 | 2          | KEGELROLLENLAGER  | TAP-ROLLER BEARING | ROULEM A ROUL CON  | COJ. RODIL-CONICOS | 31307 DIN 720   | 01  |
| 71       | 116 6121 | 1          | RUNDGUMMRING      | O-SEAL             | ANNEAU TORIQUE     | ANILLO GOMA REDOND | 90 X 2 H 721  | 01  |
| 72       | 339 2440 | 1          | LAGERFLANSCH      | BEARING FLANGE     | BRIDE SUPPORT      | BRIDA SOPORTE      | 1445-11-01-44   |     |
| 77       | 339 2235 | 1          | VERBINDUNGSTUECK  | CONNECTING PIECE   | RACCORD            | PIEZA UNION        | 1434-11-01-65   |     |
| 78       | 110 7808 | 1          | SICHERUNGSRING    | CIRCLIP            | CIRCLIP            | CIRCLIP            | 19X1 DIN 472  |     |
| 81       | 233 3405 | 1          | LAGERBUCHSE       | BEARING BUSH       | DOUILLE PALIER     | CASQUILLO SOPORTE  |   |     |
| 82       | 110 4273 | 1          | ZYLINDERSTIFT     | PARALLEL PIN       | GOUPILLE CYLINDR.  | PERNO CILINDRICO   | 3 H 6X 5DIN 7   |     |
| 83       | 111 5459 | 1          | SPANNHUELSE       | BOWEL SLEEVE       | DOUILLE SERRAGE    | CASQUILLO FIADOR   | 6 X 45DIN 1481  |     |
| 88       | 110 7742 | 1          | SICHERUNGSRING    | CIRCLIP            | CIRCLIP            | CIRCLIP            | 30X1,5 DIN 471  |     |
| 89       | 233 3425 | 1          | ANLAUFSCHLEIBE    | STOP WASHER        | DISQUE BUTEE       | ARANDELA TOPE      |   |     |
| 90       | 116 8738 | 2          | NADELKAEFIG       | NEEDLE GAGE        | CAGE A AIGUILLES   | JAULA AGUJAS       | HS 30 X 35X17 H 4455                                    | 01  |
| 91       | 233 3404 | 1          | RUECKLAUFWELLE    | RETURN SHAFT       | ARBRE DE MARCHE AR | EJE MARCHA ATRAS   |   |     |
| 102      | 233 4004 | 1          | ZAHNRAD           | GEAR               | ROUE DENTEE        | RUEDA DENTADA      | Z 43  |     |
| 103      | 233 4005 | 1          | ZAHNRAD           | GEAR               | ROUE DENTEE        | RUEDA DENTADA      | Z 38  |     |
| 104      | 233 3413 | 1          | RUECKLAUFRAD      | REVERSE GEAR       | ROUE DE MARCHE AR  | RUEDA MRCHA ATRAS  | Z 26  |     |
| 105      | 230 1206 | 1          | ZAHNRAD           | GEAR               | ROUE DENTEE        | RUEDA DENTADA      | 4-6-2 16 31   |     |
| 106      | 230 1172 | 1          | ZAHNRAD           | GEAR               | ROUE DENTEE        | RUEDA DENTADA      | Z 28  |     |
| 107      | 230 1653 | 1          | ANTRIEBSWELLE     | DRIVE SHAFT        | ARBRE DE COMMANDE  | EJE MOTRIZ         |   |     |
| 108      | 231 6826 | 1          | ZAHNRAD           | GEAR               | ROUE DENTEE        | RUEDA DENTADA      | 1-6-2 53  |     |
| 111      | 116 8764 | 1          | NADELKAEFIG       | NEEDLE GAGE        | CAGE A AIGUILLES   | JAULA AGUJAS       | K 35 X 42X16 F H 4455                                   | 01  |
| 112      | 116 8713 | 1          | NADELKAEFIG       | NEEDLE GAGE        | CAGE A AIGUILLES   | JAULA AGUJAS       | 6 35 X 42X16 H 4455                                     | 01  |
| 113      | 238 1081 | SZ         | BEILAGE           | SHIM               | CALE               | SUPLEMENTO         | 8003-AB FAHRGESTELL-NR<br>8076-EINZELT-SIEH-P05-970-976 |     |
| 114      | 233 6405 | 1          | ZYL.-ROLLENLAGER  | PAR-ROLL-BEARING   | ROULEM.ROUL.CYL.   | COJ.RODIL.CILINDR  |   | 01  |
| 116      | 233 5951 | 16         | SCHALTBOLZEN      | SHIFT PIN          | AXE COMMANDE       | BULON CAMBIO       |   |     |
| 117      | 233 5932 | 1          | NADELKAEFIG       | NEEDLE GAGE        | CAGE A AIGUILLES   | JAULA AGUJAS       |   | 01  |
| 120      | 230 2056 | NB         | BEILAGE           | SHIM               | CALE               | SUPLEMENTO         | A 1,0 MM  |     |
| 121      | 230 2057 | NB         | BEILAGE           | SHIM               | CALE               | SUPLEMENTO         | A 1,1 MM  |     |
| 122      | 230 2058 | NB         | BEILAGE           | SHIM               | CALE               | SUPLEMENTO         | A 1,2 MM  |     |
| 123      | 230 2059 | NB         | BEILAGE           | SHIM               | CALE               | SUPLEMENTO         | A 1,3 MM  |     |
| 124      | 230 2060 | NB         | BEILAGE           | SHIM               | CALE               | SUPLEMENTO         | A 1,4 MM  |     |
| 125      | 230 2061 | NB         | BEILAGE           | SHIM               | CALE               | SUPLEMENTO         | A 1,5 MM  |     |
| 126      | 230 2062 | NB         | BEILAGE           | SHIM               | CALE               | SUPLEMENTO         | A 1,6 MM  |     |
| 127      | 230 2063 | NB         | BEILAGE           | SHIM               | CALE               | SUPLEMENTO         | A 1,7 MM  |     |
| 128      | 230 2064 | NB         | BEILAGE           | SHIM               | CALE               | SUPLEMENTO         | A 2,0 MM  |     |
| 129      | 230 2067 | NB         | BEILAGE           | SHIM               | CALE               | SUPLEMENTO         | A 2,25 MM   |     |
| 130      | 230 2068 | NB         | BEILAGE           | SHIM               | CALE               | SUPLEMENTO         | A 2,5 MM  |     |

| Bid Nr. | Teil-Nr. | Stück-Zahl | Deutsch | English | Français | Español  | Nummer/Bemerkung           | ETK |
|---------|----------|------------|---------|---------|----------|----------|----------------------------|-----|
| 761     | 230 2049 | NB         | BEILAGE | SHIM    | CALE     | SUPLENTO | A 2.75 MM                  |     |
| 762     | 230 2050 | NB         | BEILAGE | SHIM    | CALE     | SUPLENTO | A 3.0 MM                   |     |
| 763     | 230 2051 | NB         | BEILAGE | SHIM    | CALE     | SUPLENTO | A 3.25 MM                  |     |
| 764     | 230 2052 | NB         | BEILAGE | SHIM    | CALE     | SUPLENTO | A 1.75 MM                  |     |
| 765     | 339 1875 | NB         | BEILAGE | SHIM    | CALE     | SUPLENTO | 1424-11-02-01<br>A 0.5 MM  |     |
| 766     | 339 1876 | NB         | BEILAGE | SHIM    | CALE     | SUPLENTO | 1424-11-02-02<br>A 0.63 MM |     |
| 767     | 339 1877 | NB         | BEILAGE | SHIM    | CALE     | SUPLENTO | 1424-11-02-03<br>A 0.75 MM |     |
| 768     | 339 1878 | NB         | BEILAGE | SHIM    | CALE     | SUPLENTO | 1424-11-02-04<br>A 0.88 MM |     |
| 769     | 339 1879 | NB         | BEILAGE | SHIM    | CALE     | SUPLENTO | 1424-11-02-05<br>A 1.0 MM  |     |
| 770     | 238 1082 | NB         | BEILAGE | SHIM    | CALE     | SUPLENTO | A 1.75 MM                  |     |
| 771     | 238 1083 | NB         | BEILAGE | SHIM    | CALE     | SUPLENTO | A 2.0 MM                   |     |
| 772     | 238 1084 | NB         | BEILAGE | SHIM    | CALE     | SUPLENTO | A 2.25 MM                  |     |
| 773     | 238 1085 | NB         | BEILAGE | SHIM    | CALE     | SUPLENTO | A 2.5 MM                   |     |
| 774     | 238 1086 | NB         | BEILAGE | SHIM    | CALE     | SUPLENTO | A 2.75 MM                  |     |
| 775     | 238 1087 | NB         | BEILAGE | SHIM    | CALE     | SUPLENTO | A 3.0 MM                   |     |
| 776     | 238 1088 | NB         | BEILAGE | SHIM    | CALE     | SUPLENTO | A 3.25 MM                  |     |

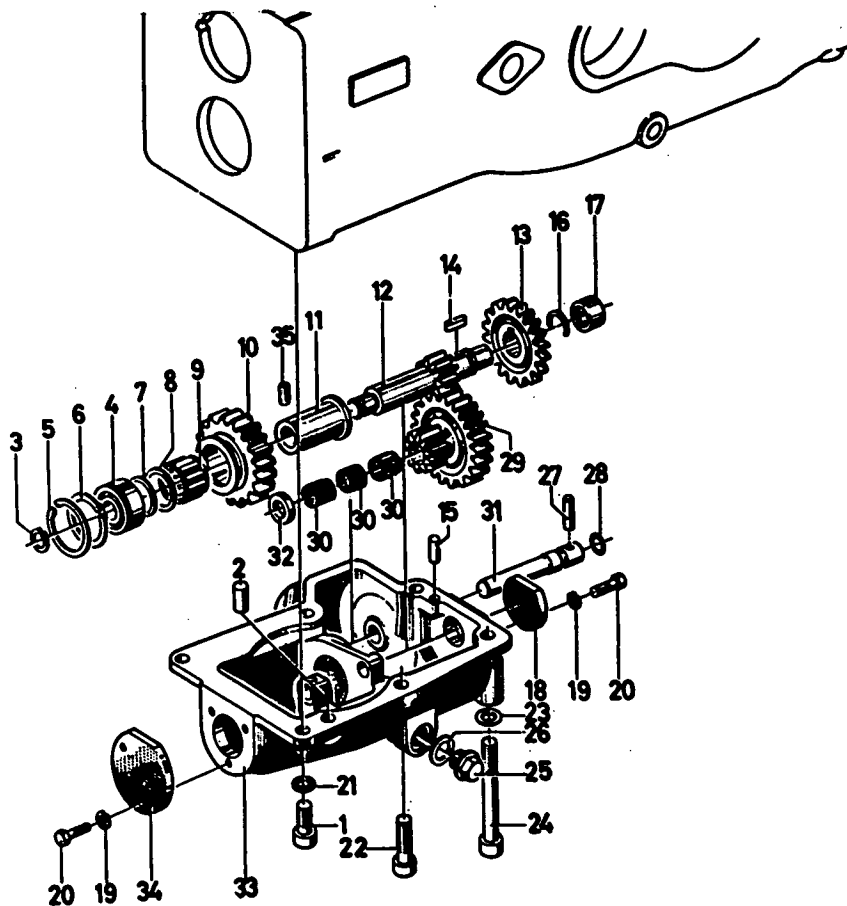
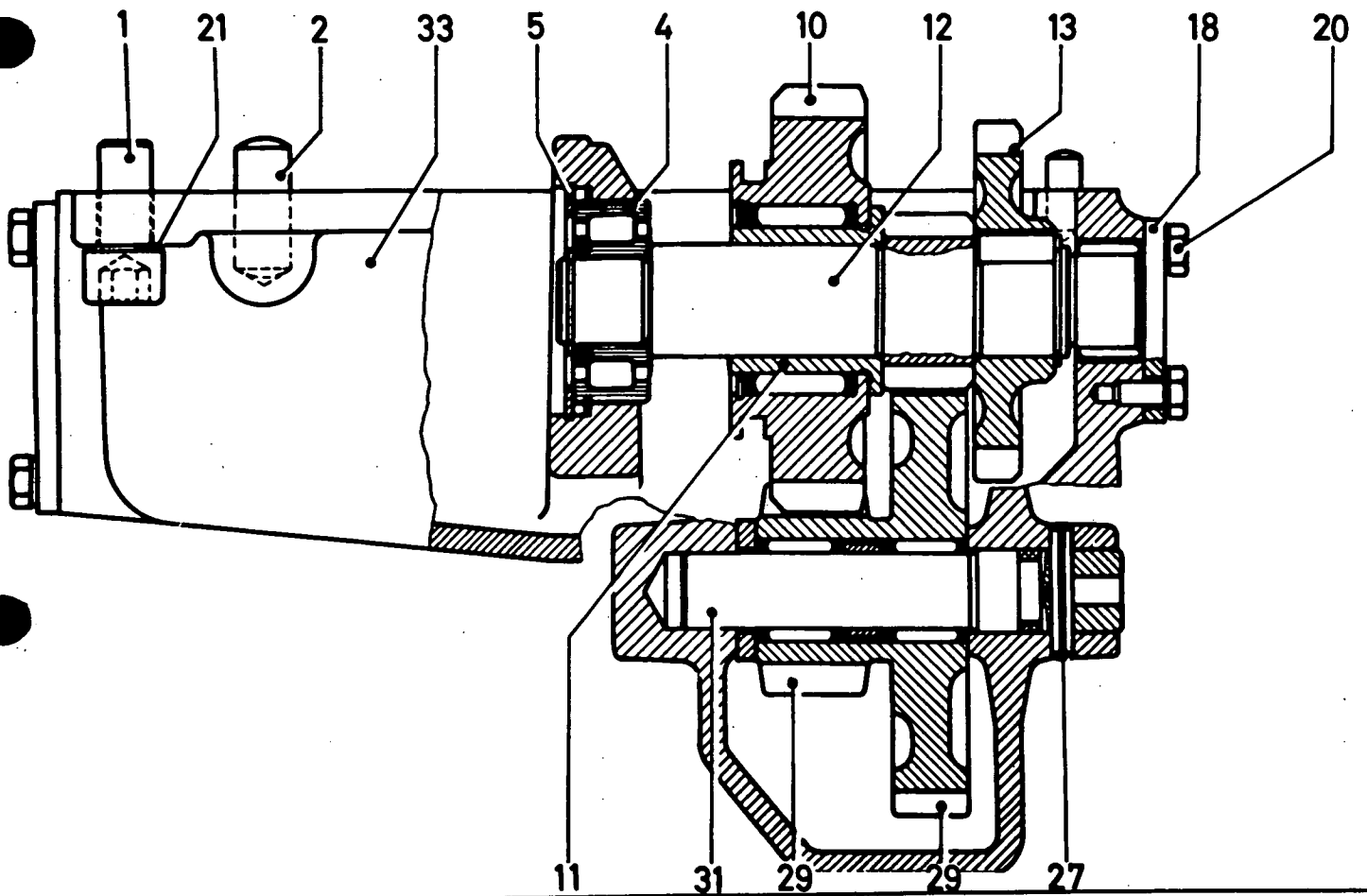

| Bd<br>Nr. | Teil-Nr. | Stück-<br>Zahl | Deutsch            | English           | Français           | Español            | Nummer/Bemerkung         | ETK |
|-----------|----------|----------------|--------------------|-------------------|--------------------|--------------------|--------------------------|-----|
| 1         | 111 0752 | 3              | ZYLINDERSCHRAUBE   | CHEESE-HEAD SCREW | VIS TETE CYLINDR.  | TORN-CBZA-CILIND.  | M12X 25DIN 932- 8-8      |     |
| 2         | 110 5213 | 1              | ZYLINDERSTIFT      | PARALLEL PIN      | GOUPILLE CYLINDR.  | PERNO CILINDRICO   | 13 M 6X 28DIN 7          |     |
| 3         | 110 7730 | 1              | SICHERUNGSRING     | CIRCLIP           | CIRCLIP            | CIRCLIP            | 20X1,2 DIN 471           |     |
| 4         | 110 2016 | 1              | ZYL.-ROLLENLAGER   | PAR.ROLL-BEARING  | ROULEM-ROUL-CYL.   | COJ-RODILL-CILINDR | MUP 2204N DIN 5412       | 01  |
| 5         | 110 2022 | 1              | SICHERUNGSRING     | CIRCLIP           | CIRCLIP            | CIRCLIP            | 52X2 DIN 984             |     |
| 6         | 110 2017 | 1              | SPRENGRING         | SNAP RING         | AGRAFE CIRCULAIRE  | ANILLO RETENCION   | SP 47DIN 5417            |     |
| 7         | 110 7747 | 1              | SICHERUNGSRING     | CIRCLIP           | CIRCLIP            | CIRCLIP            | 34X1,5 DIN 471 VZKC      |     |
| 8         | 232 9646 | 8              | ANLAUFSCHLEIBE     | STOP WASHER       | DISQUE BUTEE       | ARANDELA TOPE      |                          |     |
| 9         | 116 1871 | 1              | NADELKAEFIG        | NEEDLE GAGE       | CAGE A AIGUILLES   | JAULA AGUJAS       | K 34 X 44X26 H 4455      | 01  |
| 10        | 232 9647 | 1              | SCHALTRAD          | GEAR/WHEEL        | ROUE COMMANDE      | RUEDA CAMBIO/MANRO | Z 26                     |     |
| 11        | 232 9645 | 1              | LAGERBUCHSE        | BEARING BUSH      | BAGUE DE PALIER    | CASQU-COJINETE     |                          |     |
| 12        | 232 9648 | 1              | ANTRIEBSWELLE      | DRIVE SHAFT       | ARBRE DE COMMANDE  | EJE MOTRIZ         | Z 12                     |     |
| 13        | 231 1569 | 1              | ZAHNRAD            | GEAR              | ROUE DENTEE        | RUEDA DENTADA      | Z 21                     |     |
| 14        | 110 2018 | 2              | PASSFEDER          | KEY               | CLAVETTE ENCASTREE | LENGUETA AJUSTE    | A 8X 7X 18 DIN 6885-C45  |     |
| 15        | 110 5155 | 1              | ZYLINDERSTIFT      | PARALLEL PIN      | GOUPILLE CYLINDR.  | PERNO CILINDRICO   | 8 M 6X 16DIN 7           |     |
| 16        | 121 0937 | 1              | RINGHAELFTE        | HALF-RING         | DEMI-BAGUE         | MITAD ANILLO       | 2 270 H 26               | 01  |
| 17        | 116 8730 | 1              | NADELHUELSE        | NEEDLE SLEEVE     | DOUILLE AIGUILLES  | CASO AGUJA         | HK 22 X 25X16 H 4455     | 01  |
| 18        | 231 1568 | 1              | DECKEL             | COVER             | COUVERCLE          | TAPA               |                          |     |
| 19        | 110 2797 | 6              | FEDERRING          | SPRING LOCKWASHER | RONDELLE GROMER    | ARANDELA ELASTICA  | A 6 DIN 128 A4C          |     |
| 20        | 111 2240 | 6              | SECHSKANTSCHRAUBE  | HEX-BOLT          | VIS 6 PANS         | TORNILLO HEXAGONAL | M 6X 12 DIN 933- 8-8-A4C |     |
| 21        | 110 2801 | 4              | FEDERRING          | SPRING LOCKWASHER | RONDELLE GROMER    | ARANDELA ELASTICA  | A 12 DIN 128 A4C         |     |
| 22        | 110 2014 | 1              | ZYLINDERSCHRAUBE   | CHEESE-HEAD SCREW | VIS TETE CYLINDR.  | TORN-CBZA-CILIND.  | M12 X20DIN 7984          |     |
| 23        | 111 8673 | 2              | DICHTRING          | WASHER            | BAGUE D ETANCHEITE | ANILLO DE JUNTA    | A 22 X 15,5DIN 7603-CU   |     |
| 24        | 110 2013 | 2              | ZYLINDERSCHRAUBE   | CHEESE-HEAD SCREW | VIS TETE CYLINDR.  | TORN-CBZA-CILIND.  | M12X 95DIN 932- 8-8-A4C  |     |
| 25        | 111 8979 | 1              | VERSCHLUSSSCHRAUBE | SCREW PLUG        | BOUCHON FILETE     | TAPON ROSCADO      | AM22X1,5 DIN 7604        |     |
| 26        | 111 8737 | 1              | DICHTRING          | WASHER            | BAGUE D ETANCHEITE | ANILLO DE JUNTA    | A 22 X 27 DIN 7603-CU    |     |
| 27        | 111 5440 | 1              | SPANNHUELSE        | DOWEL SLEEVE      | DOUILLE SERRAGE    | CASQUILLO FIADOR   | 5 X 32DIN 1461           |     |
| 28        | 116 6000 | 1              | RUNDGUMMIRING      | O-SEAL            | ANNEAU TORIQUE     | ANILLO GOMA REDOND | 14 X 3 H 721             | 01  |
| 29        | 232 9664 | 1              | ZAHNRAD            | GEAR              | ROUE DENTEE        | RUEDA DENTADA      | Z 11/35                  |     |
| 30        | 116 8717 | 3              | NADELKAEFIG        | NEEDLE GAGE       | CAGE A AIGUILLES   | JAULA AGUJAS       | H9 19 X 23X17 H 4455     | 01  |
| 31        | 232 9665 | 1              | BOLZEN             | PIN/BOLT/STUD     | BOULON/AXE         | BULON              |                          |     |
| 32        | 233 3995 | 1              | ANLAUFSCHLEIBE     | STOP WASHER       | DISQUE BUTEE       | ARANDELA TOPE      |                          |     |
| 33        | 233 3406 | 1              | GEHAEUSE           | HOUSING/CASE      | CARTER/BOITIER     | CAJA/BLOQUE/CUERPO |                          |     |
| 34        | 231 1684 | 1              | DECKEL             | COVER             | COUVERCLE          | TAPA               |                          |     |
| 35        | 110 4273 | 1              | ZYLINDERSTIFT      | PARALLEL PIN      | GOUPILLE CYLINDR.  | PERNO CILINDRICO   | 3 M 6X 5DIN 7            |     |

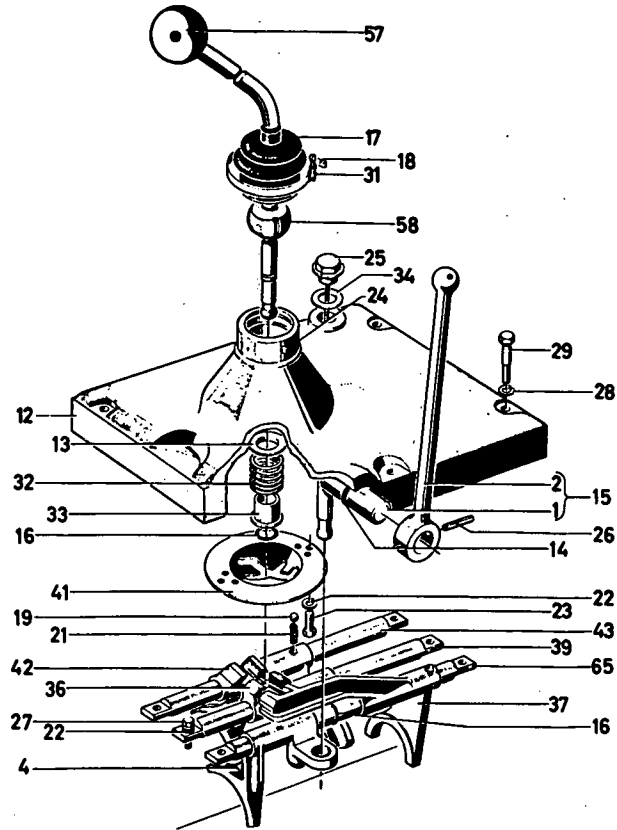

| Bild Nr. | Teil-Nr. | Stück-Zahl | Deutsch           | English            | Français           | Español            | 1445-12 500 4187<br>Nummer/Bemerkung | ETK |
|----------|----------|------------|-------------------|--------------------|--------------------|--------------------|--------------------------------------|-----|
| 1        | 231 6498 | 1P         | SCHALTWELLE       | SHIFTING SHAFT     | ARBRE COMMANDE     | EJE MANDO/CAMBIO   | 1424-12-03-10                        |     |
| 2        | 339 1935 | 1          | SCHALTHEBEL       | SHIFT LEVER        | LEVIER COMMANDE    | PALANCA CAMBIO     | 1424-12-03-03                        |     |
| 4        | 339 2471 | 1          | SCHALTGABEL       | SHIFT FORK         | FOURCHETTE CDE     | HORQUILLA CAMBIO   | 1445-12-01-04                        |     |
| 12       | 230 3572 | 1          | SCHALTDECKEL      | COVER              | COUVERCLE COMMANDE | TAPA CAMBIO        |                                      |     |
| 13       | 339 1943 | 1          | SCHEIBE           | DISC/PANE/PLATE    | RONDELLE/DISQUE    | DISCO              | 1424-12-05-12                        |     |
| 14       | 116 6000 | 1          | RUNDGUMMIRING     | O-SEAL             | ANNEAU TORIQUE     | ANILLO GOMA REDOND | 14 X 3 H 721                         | 01  |
| 15       | 339 1937 | 1          | SCHALTWELLE       | SHIFTING SHAFT     | ARBRE COMMANDE     | EJE MANDO/CAMBIO   | 1424-12-03-20                        |     |
| 16       | 111 9824 | 2          | SPRENGRING        | SNAP RING          | AGRAFE CIRCULAIRE  | ANILLO RETENCION   | 140IN 9045                           |     |
| 17       | 339 1929 | 1          | FALTENBALG        | BELLOWS            | SOUFFLET           | FUELLE             | 1424-12-01-16                        | 01  |
| 18       | 116 6345 | HTP        | SCHLAUCHBAND      | HOSE STRAP         | RUBAN SERRAGE      | CINTA ATAMANGUERA  | B H: 735                             |     |
| 19       | 111 6756 | 4          | KUGEL             | BALL               | BILLE/BOULE        | BOLA               | 8 MM III DIN 5401                    |     |
| 21       | 338 6770 | 4          | DRUCKFEDER        | COMPRESSION SPRING | RESSORT DE COMPR   | RESORTE PRESSION   | 1055-12-01-33                        | 01  |
| 22       | 110 2797 | 8          | FEDERRING         | SPRING LOCKWASHER  | RONDELLE GROWER    | ARANDELA ELASTICA  | A 6 DIN 128 A4C                      |     |
| 23       | 111 2238 | 2          | SECHSKANTSCHRAUBE | HEX-BOLT           | VIS 6 PANS         | TORNILLO HEXAGONAL | M 6 X 12 DIN 933- 8-8                |     |
| 24       | 110 5127 | 1          | ZYLINDERSTIFT     | PARALLEL PIN       | GOUPILLE CYLINDR.  | PERNO CILINDRICO   | 6 M 6 X 12DIN 7                      |     |
| 25       | 339 1950 | 1          | ÖELMESSSTAB       | OIL DIPSTICK       | JAUGE D HUILE      | VARIL-NIVEL ACEITE | 1424-12-07-20                        |     |
| 26       | 111 5456 | 1          | SPANNHUELSE       | DOWEL SLEEVE       | DOUILLE SERRAGE    | CASQUILLO FIADOR   | 6 X 36DIN 1481                       |     |
| 27       | 111 2255 | 6          | SECHSKANTSCHRAUBE | HEX-BOLT           | VIS 6 PANS         | TORNILLO HEXAGONAL | M 6 X 18 DIN 933- 8-8                |     |
| 28       | 110 2799 | 6          | FEDERRING         | SPRING LOCKWASHER  | RONDELLE GROWER    | ARANDELA ELASTICA  | A 8 DIN 128 A4C                      |     |
| 29       | 111 1142 | 6          | SECHSKANTSCHRAUBE | HEX-BOLT           | VIS 6 PANS         | TORNILLO HEXAGONAL | M 8 X 40 DIN 931-M 8-8               |     |
| 31       | 116 6343 | 1          | SCHLAUCHBINDER    | HOSE FASTENER      | ATTACHE RUBAN      | ATAMANGUERA        | A H 735                              |     |
| 32       | 339 1944 | 1          | DRUCKFEDER        | COMPRESSION SPRING | RESSORT DE COMPR   | RESORTE PRESSION   | 1424-12-05-33                        | 01  |
| 33       | 339 1933 | 1          | FEDERTELLER       | SPRING CAP         | CUVETTE DE RESSORT | PLATO RESORTE      | 1424-12-01-34                        |     |
| 34       | 111 8737 | 1          | DICHTRING         | WASHER             | BAGUE D ETANCHEITE | ANILLO DE JUNTA    | A 22 X 27 DIN 7603-CU                | 01  |
| 36       | 339 2477 | 1          | SCHALTGABEL       | SHIFT FORK         | FOURCHETTE CDE     | HORQUILLA CAMBIO   | 1445-12-01-36<br>I-II-6.             |     |

| Bld<br>Nr. | Teil-Nr. | Stück-<br>Zahl | Deutsch        | English         | Francais        | Espanol           | Nummer/Bemerkung                 | ETK |
|------------|----------|----------------|----------------|-----------------|-----------------|-------------------|----------------------------------|-----|
| 37         | 339 2478 | 1              | SCHALTGABEL    | SHIFT FORK      | FOURCHETTE CDE  | HORQUILLA CAMBIO  | 1445-12-01-37<br>III-IV-6.       |     |
| 39         | 339 2261 | 1              | SCHALTSTANGE   | SHIFT ROD       | BARRE EMBRAYAGE | BARRA CAMBIO      | 1434-12-01-03<br>I-II-6.         |     |
| 41         | 339 2264 | 1              | KULISSE        | GUIDE SLOT/GATE | COULISSE/GRILLE | PLACA GUIA        | 1434-12-01-09                    |     |
| 42         | 339 2480 | 1              | SCHALTGABEL    | SHIFT FORK      | FOURCHETTE CDE  | HORQUILLA CAMBIO  | 1445-12-01-42<br>R               |     |
| 43         | 339 1926 | 1              | SCHALTSTANGE   | SHIFT ROD       | BARRE EMBRAYAGE | BARRA CAMBIO      | 1424-12-01-04<br>R               |     |
| 57         | 116 3642 | 1              | KNOPF          | BUTTON/KNOB     | BOUTON          | BOTON             | 840X14H 3517 PRESSTOFF MATT      |     |
| * 58       | 232 9913 | 1              | SCHALTKNUEPPEL | SHIFT STICK     | LEVIER CDE VIT  | PALANCA DE CAMBIO |                                  |     |
| 65         | 233 9263 | 1              | SCHALTSTANGE   | SHIFT ROD       | BARRE EMBRAYAGE | BARRA CAMBIO      | 8128-FUER VORGELEGE.<br>+ 309 G. |     |
| * 0232     |          | 9573           |                |                 |                 |                   |                                  |     |

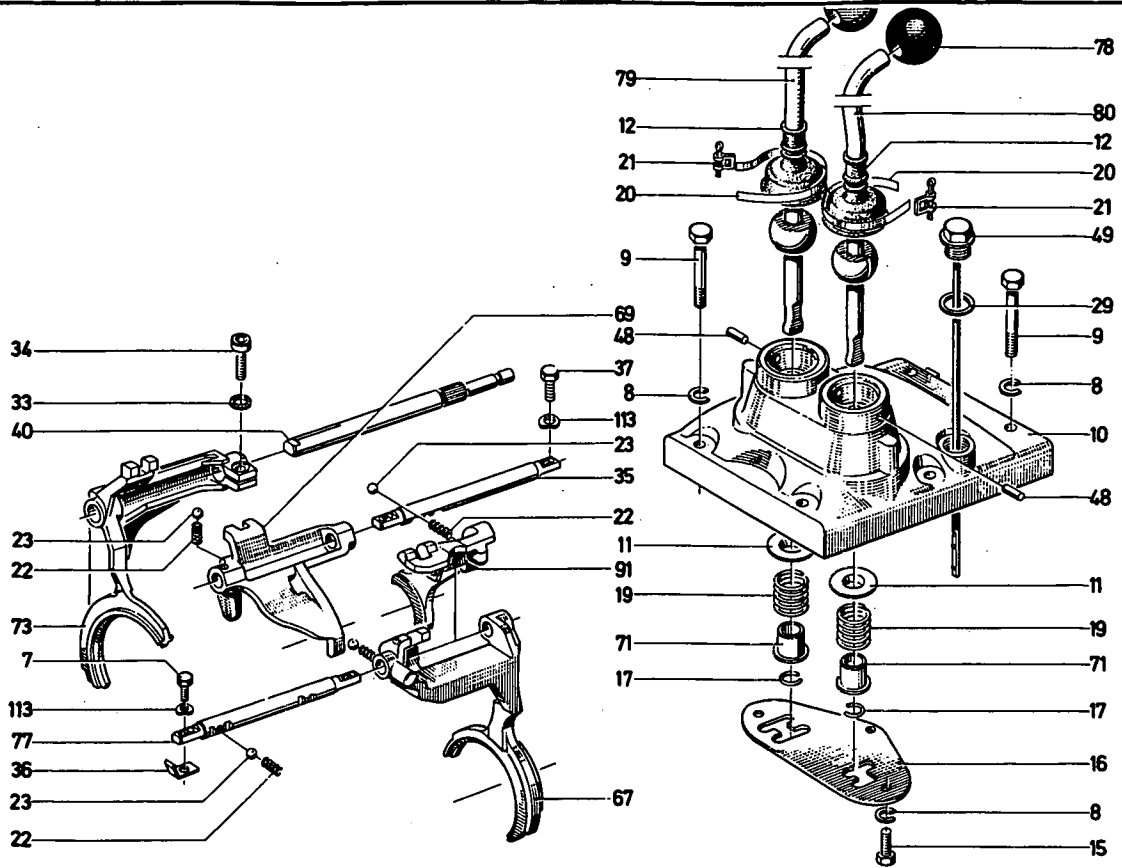

1446-12 500 4189

| Bild Nr. | Teil-Nr. | Stück-Zahl | Deutsch            | English            | Français           | Español            | Nummer/Bemerkung           | ETK |
|----------|----------|------------|--------------------|--------------------|--------------------|--------------------|----------------------------|-----|
| 7        | 111 2255 | 2          | SECHSKANTSCHRAUBE  | HEX-BOLT           | VIS 6 PANS         | TORNILLO HEXAGONAL | M 6 X 18 DIN 933- 2-2      |     |
| 8        | 110 2799 | 9          | FEDERRING          | SPRING LOCKWASHER  | RONDELLE GROWER    | ARANDELA ELASTICA  | A 8 DIN 128 A4C            |     |
| 9        | 111 1145 | 6          | SECHSKANTSCHRAUBE  | HEX-BOLT           | VIS 6 PANS         | TORNILLO HEXAGONAL | M 8 X 40 DIN 931-M 8-8 A4C |     |
| 10       | 230 1501 | 1          | SCHALTBECKEL       | COVER              | COUVERCLE COMMANDE | TAPA CAMBIO        |                            |     |
| 11       | 339 1943 | 2          | SCHLEIBE           | DISC/PANE/PLATE    | RONDELLE/DISQUE    | DISCO              | 1424-12-05.12              |     |
| 12       | 339 1929 | 2          | FALTENEALG         | BELLOWS            | SOUFFLET           | FUELLE             | 1424-12-01.16              | 01  |
| 15       | 111 2305 | 3          | SECHSKANTSCHRAUBE  | HEX-BOLT           | VIS 6 PANS         | TORNILLO HEXAGONAL | M 8 X 15 DIN 932- 2-2-A4C  |     |
| 16       | 230 1502 | 1          | KULISSE            | GUIDE SLOT/GATE    | COULISSE/GRILLE    | PLACA GUIA         |                            |     |
| 17       | 111 9824 | 2          | SPRENGRING         | SNAP RING          | AGRAFE CIRCULAIRE  | ANILLO RETENCION   | 14 DIN 9045                |     |
| 19       | 339 1944 | 2          | DRUCKFEDER         | COMPRESSION SPRING | RESSORT DE COMPR   | RESORTE PRESTON    | 1424-12-05.33              | 01  |
| 20       | 116 6347 | MTR        | SCHLAUCHBAND       | HOSE STRAP         | RUBAN SERRAGE      | CINTA ATAMANGUERA  | D H 735                    |     |
| 21       | 116 6346 | 2          | SCHLAUCHBINDER     | HOSE FASTENER      | ATTACHE RUBAN      | ATAMANGUERA        | C H 735                    |     |
| 22       | 338 6770 | 4          | DRUCKFEDER         | COMPRESSION SPRING | RESSORT DE COMPR   | RESORTE PRESTON    | 1055-12-01.33              | 01  |
| 23       | 111 6956 | 4          | KUGEL              | BALL               | BILLE/BOULE        | BOLA               | 8 MM III DIN 5403          |     |
| 29       | 111 8737 | 1          | DICHRING           | WASHER             | BAGUE D ETANCHEITE | ANILLO DE JUNTA    | A 22 X 27 DIN 7603-CU      | 01  |
| 33       | 116 9689 | 1          | SICHERUNGSSCHLEIBE | LOCKING WASHER     | RONDELLE SECURITE  | ARANDELA SEGURIDAD | 8 H 2203                   |     |
| 34       | 111 0560 | 1          | ZYLINDERSCHRAUBE   | CHEESE-HEAD SCREW  | VIS TETE CYLINDR.  | TORN-CEZA-CILIND.  | M 8 X 20 DIN 932-10-9      |     |
| 35       | 230 2212 | 1          | SCHALTSTANGE       | SHIFT ROD          | BARRE ENBRAYAGE    | BARRA CAMBIO       | 3-4-G.                     |     |
| 36       | 230 2213 | 2          | JUSTIERBLECH       | ADJUSTING PLATE    | TOLE DE REGLAGE    | CHAPA AJUSTE       |                            |     |
| 37       | 111 2264 | 2          | SECHSKANTSCHRAUBE  | HEX-BOLT           | VIS 6 PANS         | TORNILLO HEXAGONAL | M 6 X 20 DIN 933- 2-2-A4C  |     |
| 40       | 230 3174 | 1          | SCHALTSTANGE       | SHIFT ROD          | BARRE ENBRAYAGE    | BARRA CAMBIO       | 1-2-G.                     |     |
| 48       | 230 7600 | 2          | ZYLINDERSTIFT      | PARALLEL PIN       | GOUPILLE CYLINDR.  | PERNO CILINDRICO   |                            |     |
| 49       | 231 1284 | 1          | ÖLMESSSTAB         | OIL DIPSTICK       | JAUGE D HUILE      | VARIL.NIVEL ACEITE | VAR-L-D-G.                 |     |
| 67       | 231 3564 | 1          | SCHALTABEL         | SHIFT FORK         | FOURCHETTE CDE     | HORQUILLA CAMBIO   | L-S.                       |     |

| Bild Nr. | Teile-Nr. | Stück-Zahl | Deutsch        | English       | Français           | Español           | Nummer / Bemerkung          | ETK |
|----------|-----------|------------|----------------|---------------|--------------------|-------------------|-----------------------------|-----|
| 69       | 231 3568  | 1          | SCHALTGABEL    | SHIFT FORK    | FOURCHETTE CDE     | HORQUILLA CAMBIO  | 3-4-6-                      |     |
| 71       | 231 3631  | 2          | FEDERTELLER    | SPRING CAP    | CUVETTE DE RESSORT | PLATO RESORTE     |                             |     |
| 73       | 231 6796  | 1          | SCHALTGABEL    | SHIFT FORK    | FOURCHETTE CDE     | HORQUILLA CAMBIO  | 1-6-                        |     |
| 77       | 231 6972  | 1          | SCHALTSTANGE   | SHIFT ROD     | BARRE EMBRAYAGE    | BARRA CAMBIO      | L-S-R                       |     |
| 78       | 116 3642  | 2          | KNOPF          | BUTTON/KNOB   | BOUTON             | BOTON             | B40X14H 3517 PRESSTOFF MATT |     |
| 79       | 232 9536  | 1          | SCHALTKNUEPPEL | SHIFT STICK   | LEVIER CDE VIT     | PALANCA DE CAMBIO | B141-GANG                   |     |
| 80       | 232 9538  | 1          | SCHALTKNUEPPEL | SHIFT STICK   | LEVIER CDE VIT     | PALANCA DE CAMBIO | B144 GRUPPE                 |     |
| 91       | 233 4666  | 1          | SCHALTGABEL    | SHIFT FORK    | FOURCHETTE CDE     | HORQUILLA CAMBIO  | R                           |     |
| 113      | 110 7279  | 2          | FEDERSCHEIBE   | SPRING WASHER | RONDELLE ELASTIQUE | ARANDELA ELASTICA | B 6 DIN 137                 |     |



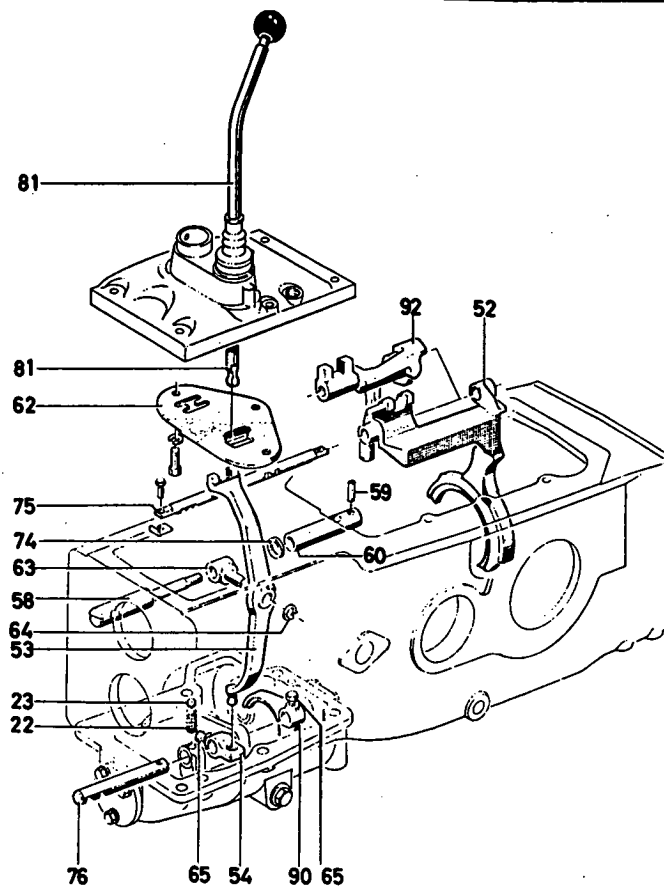

| Bld Nr. | Teil-Nr. | Stück-Zahl | Deutsch        | English            | Français           | Español           | Nummer/Bemerkung.  | ETK |
|---------|----------|------------|----------------|--------------------|--------------------|-------------------|--------------------|-----|
| 22      | 338 6770 | 1          | BRUCKFEDER     | COMPRESSION SPRING | RESSORT DE COMPR   | RESORTE PRESION   | 1055-12-01-33      | 01  |
| 23      | 111 6956 | 1          | KUGEL          | BALL               | BILLE/BOULE        | BOLA              | 8 MM III DIN 5403  |     |
| 52      | 231 1673 | 1          | SCHALTGABEL    | SHIFT FORK         | FOURCHETTE CDE     | HORQUILLA CAMBIO  | L-S                |     |
| 53      | 231 1671 | 1          | SCHALTHEBEL    | SHIFT LEVER        | LEVIER COMMANDE    | PALANCA CAMBIO    |                    |     |
| 59      | 231 1752 | 1          | ZWISCHENSTUECK | ADAPTER            | PIECE INTERCALAIRE | PIEZA INTERMEDIA  |                    |     |
| 58      | 231 1755 | 1          | BOLZEN         | PIN/BOLT/STUD      | BOULON/AXE         | BULON             |                    |     |
| 59      | 111 5459 | 1          | SPANNHUELSE    | DOWEL SLEEVE       | DOUILLE SERRAGE    | CASQUILLO FIADOR  | 6 X 45DIN 1463     |     |
| 60      | 231 1756 | 1          | ZWISCHENWELLE  | INTERMEDIATE SHAFT | ARBRE INTERN.      | EJE INTERMEDIO    |                    |     |
| 62      | 231 1762 | 1          | KULISSE        | GUIDE SLOT/GATE    | COULISSE/GRILLE    | PLACA GUIA        |                    |     |
| 63      | 231 1764 | 1          | DREHZAPPEN     | PIVOT              | PIVOT              | PIVOTE DE GIRO    |                    |     |
| 64      | 110 7721 | 1          | SICHERUNGSRING | CIRCLIP            | CIRCLIP            | CIRCLIP           | 14X1 DIN 471       |     |
| 65      | 231 1763 | 1          | KLEINMSCHRAUBE | CLAMPING SCREW     | VIS DE SERRAGE     | TORNILLO APRIETO  |                    |     |
| 74      | 232 1415 | SZ         | BEILAGE        | SHIM               | CALE               | SUPLEMENTO        | B285-SIEHE POS-950 |     |
| 75      | 232 1571 | 1          | SCHALTSTANGE   | SHIFT ROD          | BARRE EMBRAYAGE    | BARRA CAMBIO      | L-S-R              |     |
| 76      | 232 1627 | 1          | SCHALTSTANGE   | SHIFT ROD          | BARRE EMBRAYAGE    | BARRA CAMBIO      | KR.                |     |
| 81      | 232 9540 | 1          | SCHALTKNUEPPEL | SHIFT STICK        | LEVIER CDE VIT     | PALANCA DE CAMBIO | GR.                |     |
| 90      | 232 5062 | 1          | SCHALTGABEL    | SHIFT FORK         | FOURCHETTE CDE     | HORQUILLA CAMBIO  | KR.                |     |
| 92      | 233 4688 | 1          | SCHALTGABEL    | SHIFT FORK         | FOURCHETTE CDE     | HORQUILLA CAMBIO  | RWG                |     |
| 150     | 232 1417 | NB         | BEILAGE        | SHIM               | CALE               | SUPLEMENTO        | A 0,5 MM.          |     |

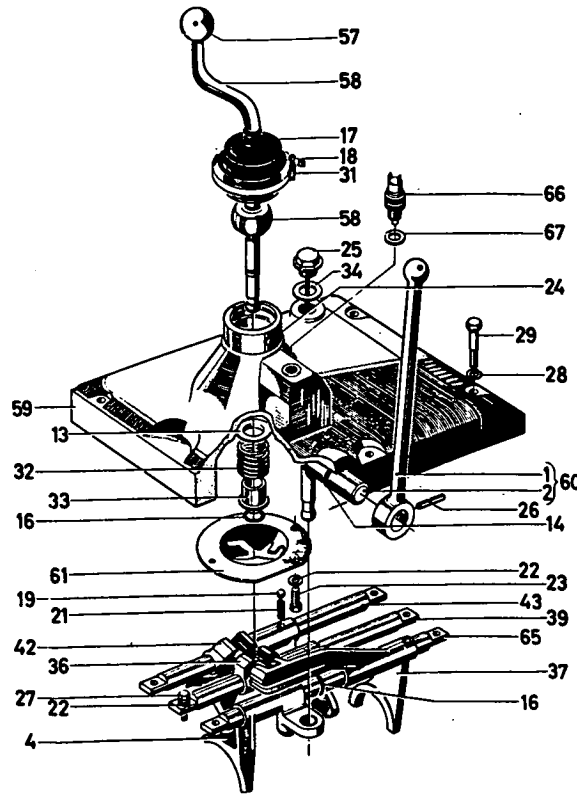

1445-12 500 4188

| Bild Nr | Teile-Nr. | Stück-Zahl | Deutsch           | English            | Français           | Español            | Number/Bemerkung               | ETK |
|---------|-----------|------------|-------------------|--------------------|--------------------|--------------------|--------------------------------|-----|
| 1       | 339 1935  | 1          | SCHALTFEBEL       | SHIFT LEVER        | LEVIER COMMANDE    | PALANCA CAMBIO     | 1424-12-03-03                  |     |
| 2       | 232 5872  | IP         | SCHALTWELLE       | SHIFTING SHAFT     | ARBRE COMMANDE     | EJE MANDO/CAMEJO   | 8285-SIEHE P05-60              |     |
| 4       | 339 2471  | 1          | SCHALTGABEL       | SHIFT FORK         | FOURCHETTE CDE     | HORQUILLA CAMEJO   | 1445-12-01-04                  |     |
| 13      | 339 1943  | 1          | SCHLEIBE          | DISC/PANE/PLATE    | RONDELLE/DISQUE    | DISCO              | 1424-12-05-12                  |     |
| 14      | 116 6000  | 1          | RUNDGUMRING       | O-SEAL             | ANNEAU TORIQUE     | ANILLO GOMA REDOND | 14 X 3 H 721                   | CI  |
| 16      | 111 9824  | 2          | SPRENGRING        | SNAP RING          | AGRAFE CIRCULAIRE  | ANILLO RETENCION   | 1407N 9045                     | CI  |
| 17      | 339 1929  | 1          | FALTENEALG        | BELLOWS            | SOUFFLET           | FUELLE             | 1424-12-01-16                  |     |
| 18      | 116 6345  | MTR        | SCHLAUCHBAND      | HOSE STRAP         | RUBAN SERRAGE      | CINTA ATAMANGUERA  | B H 735                        |     |
| 19      | 111 6956  | 4          | KUGEL             | BALL               | BILLE/BOULE        | BOLA               | 8 MM III DIN 5401              | CI  |
| 21      | 338 6770  | 4          | DRUCKFEDER        | COMPRESSION SPRING | RESSORT DE COMPR   | RESORTE PRESTON    | 1055-12-01-33                  |     |
| 22      | 110 2797  | 2          | FEDERRING         | SPRING LOCKWASHER  | RONDELLE GROWER    | ARANDELA ELASTICA  | A 6 DIN 128 A4C                |     |
| 23      | 111 2238  | 2          | SECHSKANTSCHRAUBE | HEX-BOLT           | VIS 6 PANS         | TORNILLO HEXAGONAL | M 6 X 12 DIN 933- 2-2          |     |
| 24      | 110 5127  | 1          | ZYLINDERSTIFT     | PARALLEL PIN       | GOUPILLE CYLINDR-  | PERNO CILINDRICO   | 6 M 6 X 12 DIN 7               |     |
| 25      | 339 1950  | 1          | ÖLMESSSTAB        | OIL DIPSTICK       | JAUGE D HUILE      | VARIL-NIVEL ACEITE | 1424-12-07-20                  |     |
| 26      | 111 5456  | 1          | SPANNHULSE        | DOWEL SLEEVE       | DOUILLE SERRAGE    | CASQUILLO FIADOR   | 6 X 36 DIN 1491                |     |
| 27      | 111 2255  | 6          | SECHSKANTSCHRAUBE | HEX-BOLT           | VIS 6 PANS         | TORNILLO HEXAGONAL | M 6 X 18 DIN 933- 2-2          |     |
| 28      | 110 2799  | 6          | FEDERRING         | SPRING LOCKWASHER  | RONDELLE GROWER    | ARANDELA FLASTICA  | A 8 DIN 128 A4C                |     |
| 29      | 111 1142  | 6          | SECHSKANTSCHRAUBE | HEX-BOLT           | VIS 6 PANS         | TORNILLO HEXAGONAL | M 8 X 40 DIN 931-M 2-8         |     |
| 31      | 116 6343  | 1          | SCHLAUCHRINDER    | HOSE FASTENER      | ATTACHE RUBAN      | ATAMANGLERA        | A H 735                        |     |
| 32      | 339 1944  | 1          | DRUCKFEDER        | COMPRESSION SPRING | RESSORT DE COMPR   | RESORTE PRESTON    | 1424-12-05-33                  | CI  |
| 33      | 339 1933  | 1          | FEDERTELLER       | SPRING CAP         | CUVETTE DE RESSORT | PLATO RESORTE      | 1424-12-01-34                  |     |
| 34      | 111 8737  | 1          | DICHRING          | WASHER             | BAGUE D ETANCHEITE | ANILLO DE JUNTA    | A 27 X 27 DIN 7602-CU          | CI  |
| 36      | 339 2477  | 1          | SCHALTGABEL       | SHIFT FORK         | FOURCHETTE CDE     | HORQUILLA CAMBIO   | 1445-12-01-36<br>8141.1+2 G4NG |     |
| 37      | 339 2478  | 1          | SCHALTGABEL       | SHIFT FORK         | FOURCHETTE CDE     | HORQUILLA CAMBIO   | 1445-12-01-37<br>8141.3+4GANG  |     |

| Bld<br>Nr. | Teil-Nr. | Stück-<br>Zahl | Deutsch        | English         | Français           | Español           | Nummer/Bemerkung                       | ETK |
|------------|----------|----------------|----------------|-----------------|--------------------|-------------------|--|-----|
| 39         | 339 2261 | 1              | SCHALTSTANGE   | SHIFT ROD       | BARRE EMBRAYAGE    | BARRA CAMBIO      | 1434-12-01-03<br>B141.1+2 GANG         |     |
| 42         | 339 2460 | 1              | SCHALTGABEL    | SHIFT FORK      | FOURCHETTE CDE     | HORQUILLA CAMBIO  | 1445-12-01-42<br>B271. RUECKWAERTSGANG |     |
| 43         | 339 1926 | 1              | SCHALTSTANGE   | SHIFT ROD       | BARRE EMBRAYAGE    | BARRA CAMBIO      | 1424-12-01-04<br>B271. RUECKWAERTSGANG |     |
| 57         | 116 3642 | 1              | KNOPF          | BUTTON/KNOB     | BOUTON             | BOTON             | B40X34H 3517 PRESSTOFF MATT            |     |
| 58         | 232 9913 | 1              | SCHALTKNUEPPEL | SHIFT STICK     | LEVIER CDE VIT     | PALANCA DE CAMBIO |  |     |
| 59         | 232 5870 | 1              | SCHALTBECKEL   | COVER           | COUVERCLE COMMANDE | TAPA CAMBIO       |  |     |
| 60         | 233 2751 | 1              | SCHALTWELLE    | SHIFTING SHAFT  | ARBRE COMMANDE     | EJE MANDO/CAMBIO  |  |     |
| 61         | 233 2746 | 1              | KULISSE        | GUIDE SLOT/GATE | COULISSE/GRILLE    | PLACA GUIA        |  |     |
| 65         | 233 9263 | 1              | SCHALTSTANGE   | SHIFT ROD       | BARRE EMBRAYAGE    | BARRA CAMBIO      | B141.3+4 GANG                          |     |
| 66         | 126 2510 | 1              | STIFTTASTER    | PUSHBUTTON      | TOUCHEAU           | PULSADOR          |  |     |
| 67         | 238 8144 | 1              | BEZLAGE        | SHIM            | CALE               | SUPLEMENTO        |  |     |

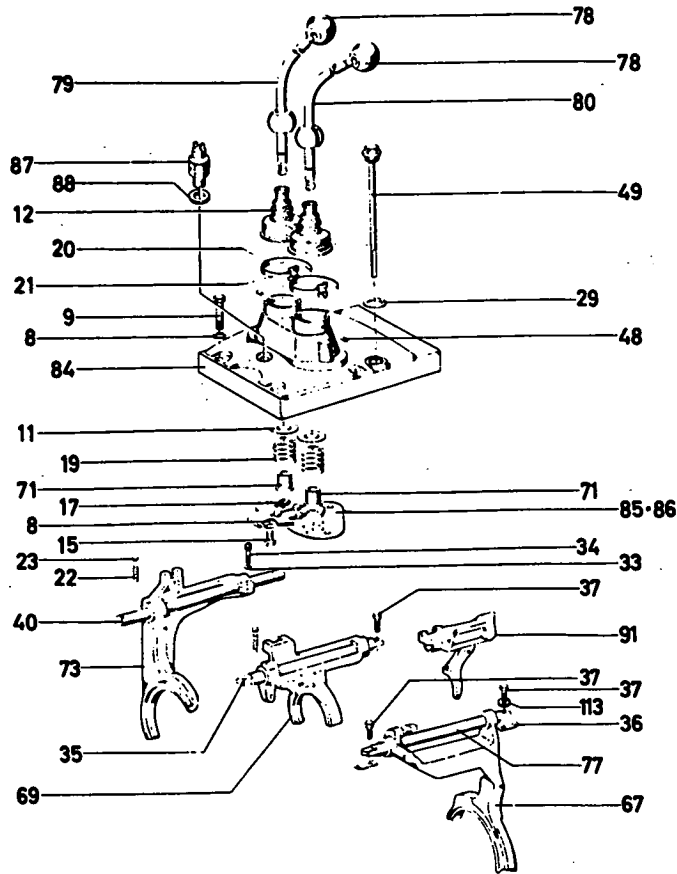

1446-12 500 4190

| Bld. Nr. | Teile-Nr. | Stück-Zahl | Deutsch           | English            | Français           | Español            | Nummer/Bemerkung           | ETK |
|----------|-----------|------------|-------------------|--------------------|--------------------|--------------------|----------------------------|-----|
| 8        | 110 2799  | 9          | FEDERRING         | SPRING LOCKWASHER  | RONDELLE GROMER    | ARANDELA ELASTICA  | A 8 DIN 128 A4C            |     |
| 9        | 111 1145  | 6          | SECHSKANTSCHRAUBE | HEX-BOLT           | VIS 6 PANS         | TORNILLO HEXAGONAL | M 8 X 40 DIN 931-M 8-8 A4C |     |
| 11       | 339 1943  | 2          | SCHEIBE           | DISC/PANE/PLATE    | RONDELLE/DISQUE    | DISCO              | 1424-12-05-12              |     |
| 12       | 339 1929  | 2          | FALTENBAG         | BELLOWS            | SOUFFLET           | FUELLE             |                            | 01  |
| 15       | 111 2305  | 3          | SECHSKANTSCHRAUBE | HEX-BOLT           | VIS 6 PANS         | TORNILLO HEXAGONAL | M 8 X 15 DIN 931- 2-2-A4C  |     |
| 17       | 111 9824  | 2          | SPRENGRING        | SNAP RING          | AGRAFE CIRCULAIRE  | ANILLO RETENCION   | 140IN 9045                 |     |
| 19       | 339 1944  | 2          | DRUCKFEDER        | COMPRESSION SPRING | RESSORT DE COMPR   | RESORTE PRESION    | 1424-12-05-33              | 01  |
| 20       | 116 6347  | NTR        | SCHLAUCHBAND      | HOSE STRAP         | RUBAN SERRAGE      | CINTA ATAMANGUERA  | D H 735                    |     |
| 21       | 116 6346  | 2          | SCHLAUCHBINDER    | HOSE FASTENER      | ATTACHE RUBAN      | ATAMANGUERA        | C H 735                    |     |
| 22       | 338 6770  | 4          | DRUCKFEDER        | COMPRESSION SPRING | RESSORT DE COMPR   | RESORTE PRESION    | 1055-12-01-33              | 01  |
| 23       | 111 6956  | 4          | KUGEL             | BALL               | BILLE/BOULE        | BOLA               | 8 MM III DIN 5961          |     |
| 29       | 111 8737  | 1          | DICHRING          | WASHER             | BAGUE D ETANCHEITE | ANILLO DE JUNTA    | A 22 X 27 DIN 7603-CU      | 01  |
| 33       | 116 9689  | 1          | SICHERUNGSSCHEIBE | LOCKING WASHER     | RONDELLE SECURITE  | ARANDELA SEGURIDAD | 8 H 2203                   |     |
| 34       | 111 0560  | 1          | ZYLINDERSCHRAUBE  | CHEESE-HEAD SCREW  | VIS TETE CYLINDR.  | TORN.CBZA.CILINDR. | M 8 X 20DIN 932-10.°       |     |
| 35       | 230 2212  | 1          | SCHALTSTANGE      | SHIFT ROD          | BARRE EMBRAYAGE    | BARRA CAMBIO       | 3-4-G.                     |     |
| 36       | 230 2213  | 2          | JUSTIERBLECH      | ADJUSTING PLATE    | TOLE DE REGLAGE    | CHAPA AJUSTE       |                            |     |
| 37       | 111 2264  | 2          | SECHSKANTSCHRAUBE | HEX-BOLT           | VIS 6 PANS         | TORNILLO HEXAGONAL | M 6 X 20 DIN 931- 2-2-A4C  |     |
| 40       | 230 3194  | 1          | SCHALTSTANGE      | SHIFT ROD          | BARRE EMBRAYAGE    | BARRA CAMBIO       | 1-2-G.                     |     |
| 48       | 230 7600  | 2          | ZYLINDERSTIFT     | PARALLEL PIN       | GOUPILLE CYLINDR.  | PERNO CILINDRICO   |                            |     |
| 49       | 231 1284  | 1          | OELMESSSTAB       | OIL DIPSTICK       | JAUGE D HUILE      | VARIL-NIVEL ACEITE | VAR-L-D-G                  |     |
| 67       | 231 3564  | 1          | SCHALTGABEL       | SHIFT FORK         | FOURCHETTE CDE     | HORQUILLA CAMBIO   | L-5                        |     |
| 69       | 231 3568  | 1          | SCHALTGABEL       | SHIFT FORK         | FOURCHETTE CDE     | HORQUILLA CAMBIO   | 3-4-G.                     |     |
| 71       | 231 3631  | 2          | FEDERTELLER       | SPRING CAP         | CUVETTE DE RESSORT | PLATO RESORTE      |                            |     |

| Bld<br>Nr. | Tele-Nr. | Stück-<br>Zahl | Deutsch        | English         | Français           | Español           | Nummer/Bemerkung              | ETK |
|------------|----------|----------------|----------------|-----------------|--------------------|-------------------|-------------------------------|-----|
| 73         | 231 6796 | 1              | SCHALTGABEL    | SHIFT FORK      | FOURCHETTE CDE     | HORQUILLA CAMBIO  | 1-6.                          |     |
| 77         | 231 6972 | 1              | SCHALTSTANGE   | SHIFT ROD       | BARRE EMBRAYAGE    | BARRA CAMBIO      | L-S-R                         |     |
| 78         | 116 3642 | 2              | KNOPF          | BUTTON/KNOB     | BOUTON             | BOTON             | B40X14H 3517 PRESSTOFF MATT   | 01  |
| 79         | 232 9536 | 1              | SCHALTKNUEPPEL | SHIFT STICK     | LEVIER CDE VIT     | PALANCA DE CAMBIO | B141.GANG                     |     |
| 80         | 232 9538 | 1              | SCHALTKNUEPPEL | SHIFT STICK     | LEVIER CDE VIT     | PALANCA DE CAMBIO | B144.GRUPPE                   | 01  |
| 84         | 233 0170 | 1              | SCHALTBECKEL   | COVER           | COUVERCLE COMMANDE | TAPA CAMBIO       |                               |     |
| 85         | 238 8060 | 1              | KULISSE        | GUIDE SLOT/GATE | COULISSE/GRILLE    | PLACA GUIA        |                               |     |
| 86         | 238 8062 | 1              | KULISSE        | GUIDE SLOT/GATE | COULISSE/GRILLE    | PLACA GUIA        | B109.FUER KRIECHGANSAUSFUEHR. | 01  |
| 87         | 126 2510 | 1              | STIFTKLEBER    | PUSHBUTTON      | TOUCHEAU           | PULSADOR          |                               |     |
| 88         | 238 8144 | 1              | BEILAGE        | SHIM            | CALE               | SUPLEMENTO        |                               | 01  |
| 91         | 233 4686 | 1              | SCHALTGABEL    | SHIFT FORK      | FOURCHETTE CDE     | HORQUILLA CAMBIO  | R                             |     |
| 113        | 110 7279 | 4              | FEDERSCHEIBE   | SPRING WASHER   | RONDELLE ELASTIQUE | ARANDELA ELASTICA | B 6 DIN 137                   |     |

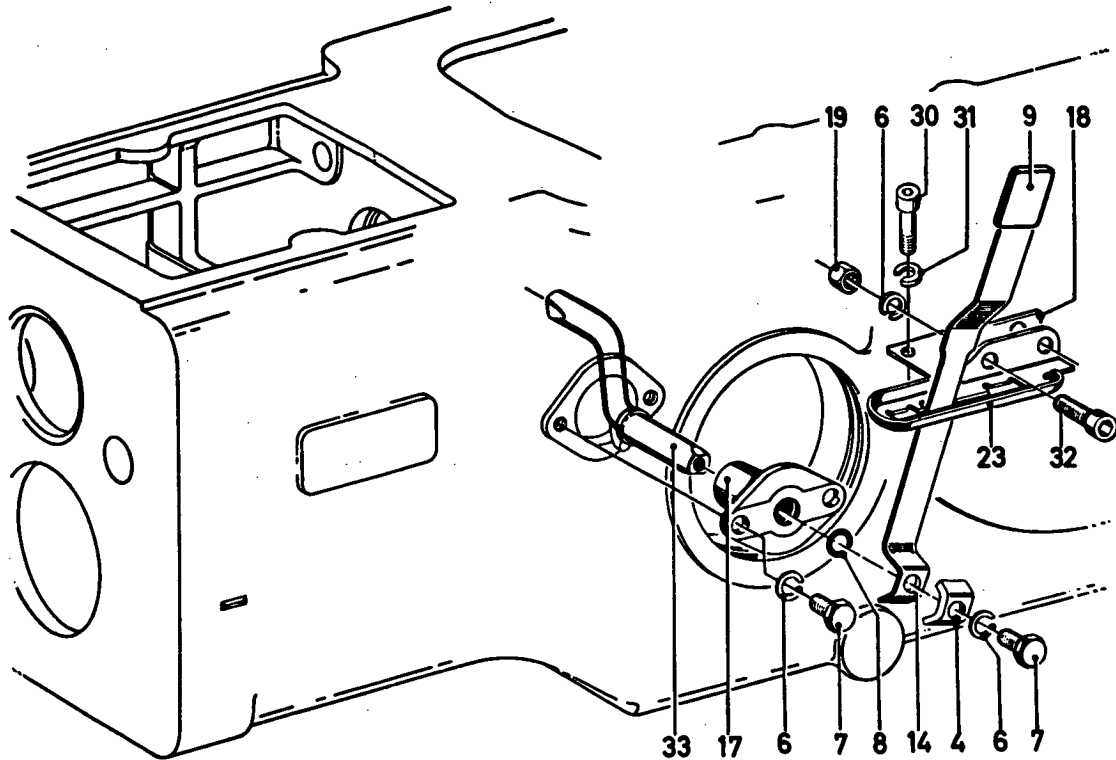

1445-14 500 4192

| Bkl Nr. | Teile-Nr. | Stück-Zahl | Deutsch           | English           | Français          | Español            | Nummer/Bemerkung         | ETK |
|---------|-----------|------------|-------------------|-------------------|-------------------|--------------------|--------------------------|-----|
| 4       | 339 0416  | 1          | KLEHMSTUECK       | CLAMP             | PIECE DE SERRAGE  | PZA-APRIETO        | 1155-14-01-04            |     |
| 6       | 110 2797  | 5          | FEDERRING         | SPRING LOCKWASHER | RONDELLE GROWER   | ARANDELA ELASTICA  | A 6 DIN 128 A4C          |     |
| 7       | 111 2320  | 3          | SECHSKANTSCHRAUBE | HEX.BOLT          | VIS 6 PANS        | TORNILLO HEXAGONAL | M 8 X 30 DIN 933- 8-8    |     |
| 8       | 116 6006  | 1          | RUNDGUMRING       | O-SEAL            | ANNEAU TORIQUE    | ANILLO GOMA REDOND | 16 X 3 H 721             | 01  |
| 9       | 339 1955  | 1          | HANDGRIFF         | HANDLE            | POIGNEE           | PUNO               | 1424-14-01-09            | 01  |
| 14      | 230 2119  | 1          | SCHALTHEBEL       | SHIFT LEVER       | LEVIER COMMANDE   | PALANCA CAMBIO     |                          |     |
| 17      | 339 3176  | 1          | BUCHSE            | BUSH              | DOUILLE           | CASQUILLO          | 1455-14-02-14            |     |
| 18      | 230 1216  | 1          | WINKEL            | ANGLE PLATE       | EQUERRE           | ANGULO             |                          |     |
| 19      | 111 2824  | 2          | SECHSKANTMUTTER   | HEX.NUT           | ECROU 6 PANS      | TUERCA HEXAGONAL   | M 8 DIN 934-M 8 A4C      |     |
| 23      | 230 2123  | 1          | KULISSE           | GUIDE SLOT/GATE   | COULISSE/GRILLE   | PLACA GUIA         |                          |     |
| 30      | 110 2193  | 2          | ZYLINDERSCHRAUBE  | CHEESE-HEAD SCREW | VIS TETE CYLINDR. | TORN-CBZA-CILIND.  | M 8 X 15DIN 932- 8-8 A4C |     |
| 31      | 111 9611  | 2          | FEDERRING         | SPRING LOCKWASHER | RONDELLE GROWER   | ARANDELA ELASTICA  | 8DIN 7950 VZKC           |     |
| 32      | 110 2194  | 2          | ZYLINDERSCHRAUBE  | CHEESE-HEAD SCREW | VIS TETE CYLINDR. | TORN-CBZA-CILIND.  | M 8 X 18DIN 932- 8-8 A4C |     |
| 33      | 231 3685  | 1          | SCHALTWELLE       | SHIFTING SHAFT    | ARBRE COMMANDE    | EJE MANDO/CAMBIO   |                          |     |

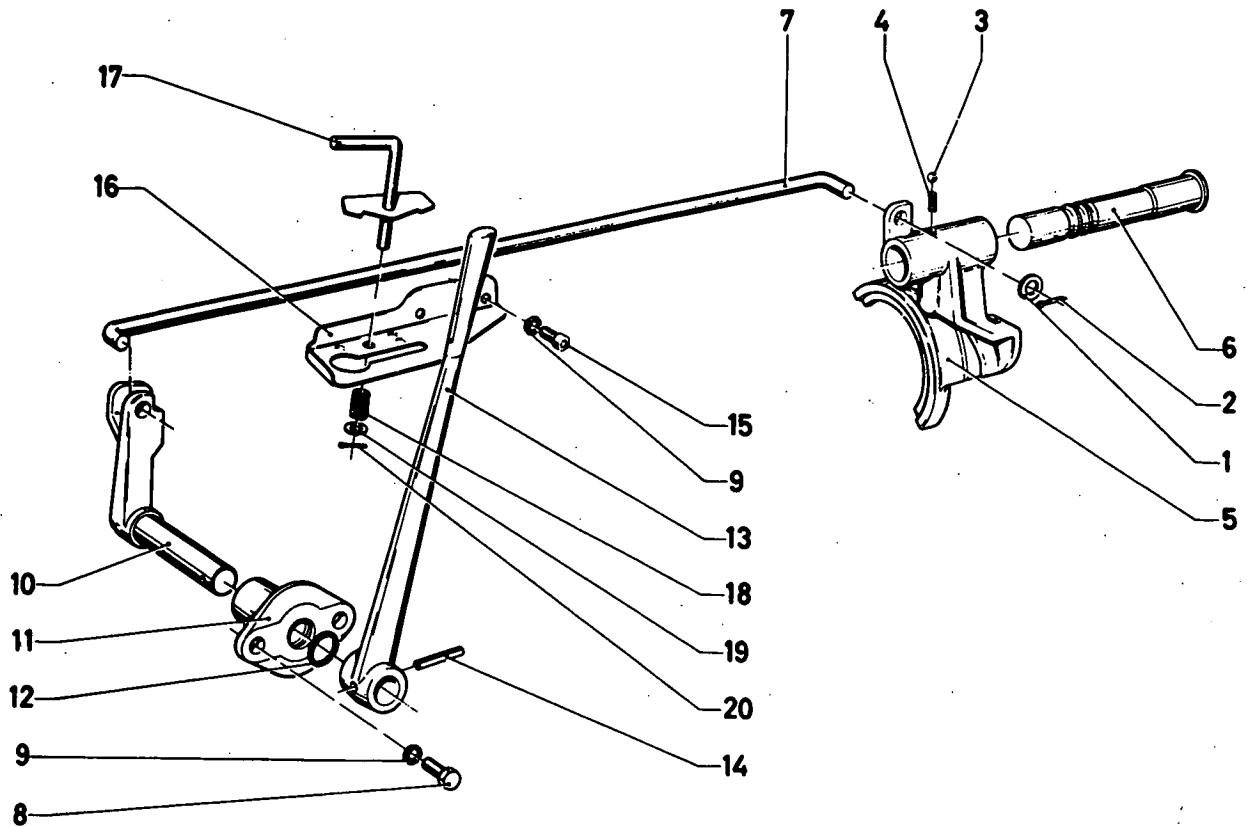

1446-14 500 5110

| Bld Nr. | Teile-Nr. | Stück-Zahl | Deutsch           | English            | Français          | Español            | Nummer/Bemerkung          | ETK |
|---------|-----------|------------|-------------------|--------------------|-------------------|--------------------|---------------------------|-----|
| 1       | 110 7549  | 1          | SCHEIBE           | DISC/PANE/PLATE    | RONDELLE/DISQUE   | DISCO              | 10.50IN 433-ST            |     |
| 2       | 110 6408  | 1          | SPLINT            | SPLIT PIN          | GOUPILLE FENDUE   | PASADOR ALETAS     | 2 X 1.60IN 94             |     |
| 3       | 111 6456  | 1          | KUGEL             | BALL               | BILLE/BOULE       | BOLA               | 8 MM III DIN 5403         |     |
| 4       | 338 6770  | 1          | DRUCKFEDER        | COMPRESSION SPRING | RESSORT DE COMPR  | RESORTE PRESION    | 1055-12-01.33             | 01  |
| 5       | 230 9176  | 1          | SCHALTGABEL       | SHIFT FORK         | FOURCHETTE CDE    | HORQUILLA CAMBIO   |                           |     |
| 6       | 230 9180  | 1          | BOLZEN            | PIN/BOLT/STUD      | BOULON/AXE        | BULON              |                           |     |
| 7       | 230 9183  | 1          | SCHALTSTANGE      | SHIFT ROD          | BARRE EMBRAYAGE   | BARRA CAMBIO       |                           |     |
| 8       | 111 2322  | 2          | SECHSKANTSCHRAUBE | HEX-BOLT           | VIS 6 PANS        | TORNILLO HEXAGONAL | M 8 X 20 DIN 933- 8.8-A4C |     |
| 9       | 116 9489  | 4          | SICHERUNGSSCHEIBE | LOCKING WASHER     | RONDELLE SECURITE | ARANDELA SEGURIDAD | 8 H 2203                  |     |
| 10      | 230 9178  | 1          | SCHALTWELLE       | SHIFTING SHAFT     | ARBRE COMMANDE    | EJE MANDO/CAMBIO   |                           |     |
| 11      | 339 3176  | 1          | BUCHSE            | BUSH               | DOUILLE           | CASQUILLO          |                           |     |
| 12      | 116 6006  | 1          | RUNDGUMMIRING     | O-SEAL             | ANNEAU TORIQUE    | ANILLO GOMA REDOND | 16 X 3 H 723              | 01  |
| 13      | 230 9181  | 1          | SCHALTHEBEL       | SHIFT LEVER        | LEVIER COMMANDE   | PALANCA CAMBIO     |                           |     |
| 14      | 111 5454  | 1          | SPANNHUELSE       | DOWEL SLEEVE       | DOUILLE SERRAGE   | CASQUILLO FIADOR   | 6 X 28DIN 1481            |     |
| 15      | 110 2193  | 2          | ZYLINDERSCHRAUBE  | CHEESE-HEAD SCREW  | VIS TETE CYLINDR. | TORN.CBZA.CILIND.  | M 8 X 15DIN 932- 8.8 A4C  |     |
| 16      | 230 7743  | 1          | KULISSE           | GUIDE SLOT/GATE    | COUISSE/GRILLE    | PLACA GUIA         |                           |     |
| 17      | 230 7739  | 1          | SPERRE            | LOCK               | DISP DE BLOCAGE   | BLOQUEO/ENCLAVAM.  |                           |     |
| 18      | 121 9657  | 1          | SCHRAUBENFEDER    | HELICAL SPRING     | RESSORT A BOUDIN  | RESORTE HELICOIDAL | 990 970 A                 | 01  |
| 19      | 110 7548  | 1          | SCHEIBE           | DISC/PANE/PLATE    | RONDELLE/DISQUE   | DISCO              | 8.40IN 433-ST-A4C         |     |
| 20      | 110 6407  | 1          | SPLINT            | SPLIT PIN          | GOUPILLE FENDUE   | PASADOR ALETAS     | 2 X 1.50IN 94-A4C         |     |

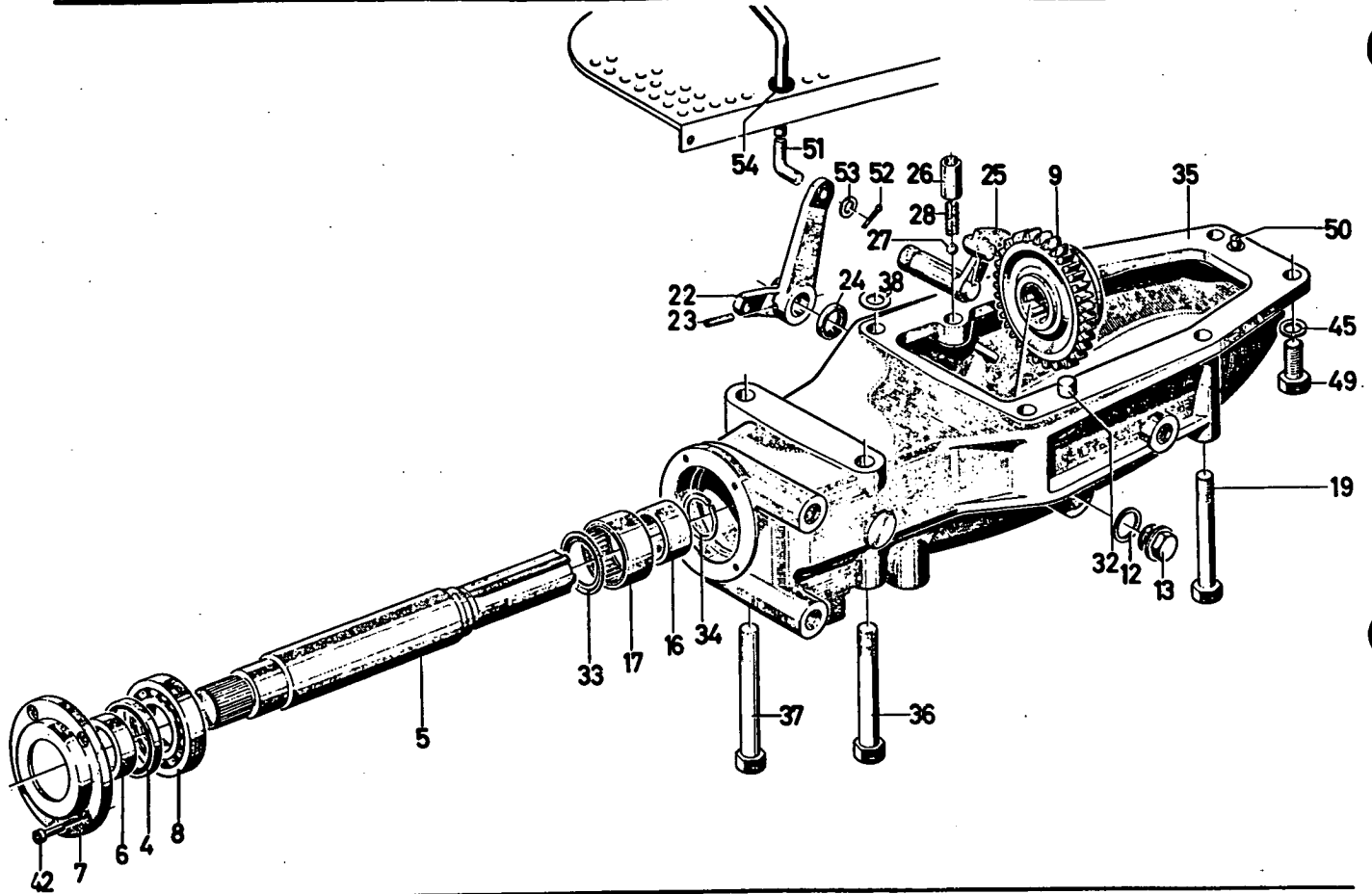

1424-17 500 4194

| Bad Nr. | Teile-Nr. | Stück-Zahl | Deutsch            | English            | Français           | Español            | Nummer/Bemerkung                                    | ETK |
|---------|-----------|------------|--------------------|--------------------|--------------------|--------------------|---|-----|
| 4       | 116 7503  | 1          | WELLENEICHTRING    | SHAFT SEAL         | JOINT D ARBRE      | ANILLO PERMETE-EJE | A 45X 60 X 7 H 2940-NI                              | 01  |
| 5       | 339 1970  | 1          | ANTRIEESWELLE      | DRIVE SHAFT        | ARBRE DE COMMANDE  | EJE MOTRIZ         | 1424-17-02-05                                       |     |
| 6       | 339 1965  | 1          | ABSTANDBUCHSE      | SPACER BUSH        | DOUILLE ECARTEN    | CASO-DISTANCIARIO  | 1424-17-01-06                                       |     |
| 7       | 339 1966  | 1          | BECKEL             | COVER              | COUVERCLE          | TAPA               | 1424-17-01-07                                       |     |
| 8       | 110 9057  | 1          | RIELENKUGELLAGER   | BALL BEARING       | ROUL RAINURE BILLE | COJ-BOLAS FIJO     | 6207 DIN 625  | 01  |
| 9       | 339 1971  | 1          | SCHALTFAD          | GEAR/WHEEL         | ROUE COMMANDE      | RUEDA CAMBIO/MANDO | 1424-17-02-09<br>Z 29                               |     |
| 12      | 111 8737  | 1          | DICHTRING          | WASHER             | BAGUE D ETANCHEITE | ANILLO DE JUNTA    | A 22 X 27 DIN 7602-CU                               |     |
| 13      | 111 8979  | 1          | VERSCHLUSSSCHRAUBE | SCREW PLUG         | BOUCHON FILETE     | TAPON ROSCADO      | AM22X1,5 DIN 7604                                   |     |
| 16      | 116 8749  | 1          | INNENRING          | INSIDE RING        | BAGUE INTERIEURE   | ANILLO INTERIOR    | IR 32 X 40X20 H 4455                                | 01  |
| 17      | 116 8778  | 1          | NADELLAGER         | NEEDLE BEARING     | ROULEM A AIGUILLES | COJ-AGUJAS         | LB 40 X 50X20 H 4455                                | 01  |
| 19      | 111 1528  | 1          | SECHSKANTSCHRAUBE  | HEX-BOLT           | VIS 6 PANS         | TORNILLO HEXAGONAL | M12X 75 SKDIN 931-M 8.8-ANC                         |     |
| 22      | 339 1969  | 1          | SCHALTHEBEL        | SHIFT LEVER        | LEVIER COMMANDE    | PALANCA CAMBIO     | 1424-17-01-22                                       |     |
| 23      | 111 5455  | 1          | SPANNHUELSE        | DOWEL SLEEVE       | DOUILLE SERRAGE    | CASQUILLO FIADOR   | 6 X 32DIN 1481                                      |     |
| 24      | 116 0500  | 1          | WELLENEICHTRING    | SHAFT SEAL         | JOINT D ARBRE      | ANILLO PERMETE-EJE | A 18X 30 X 7 H 2940-NI                              | 01  |
| 25      | 339 1974  | 1          | SCHALTWELLE        | SHIFTING SHAFT     | ARBRE COMMANDE     | EJE MANIO/CAMBIO   | 1424-17-02-25                                       |     |
| 26      | 121 6185  | 1          | SPANNSTIFT         | DOWEL PIN          | GOUPILLE SERRAGE   | PERNO FIADOR       | 2 459 A 1   |     |
| 27      | 111 6956  | 1          | KUGEL              | BALL               | BILLE/BOULE        | BOLA               | 8 MM III DIN 5401                                   |     |
| 28      | 338 6770  | 1          | BRUCKFEDER         | COMPRESSION SPRING | RESSORT DE COMPR   | RESORTE PRESION    | 1055-17-01-33                                       | 01  |
| 32      | 110 5213  | 1          | ZYLINDERSTIFT      | PARALLEL PIN       | GOUPILLE CYLINDR.  | PERNO CYLINDRICO   | 13 M 6X 28DIN 7                                     |     |
| 33      | 339 1976  | 1          | SCHEIBE            | DISC/PANE/PLATE    | RONDELLE/DISQUE    | DISCO              | 1424-17-02-33                                       |     |
| 34      | 116 7239  | 1          | SICHERUNGSRING     | CIRCLIP            | CIRCLIP            | CIRCLIP            | 32H 2271  |     |
| 35      | 339 1977  | 1          | GEMAEUSE           | HOUSING/CASE       | CARTER/BOITIER     | CAJA/BLAQUE/CUERPO | 1424-17-02-35                                       |     |
| 36      | 111 1778  | 1          | SECHSKANTSCHRAUBE  | HEX-BOLT           | VIS 6 PANS         | TORNILLO HEXAGONAL | M14X 110 DIN 931-M 8.8                              |     |
| 37      | 111 1782  | 1          | SECHSKANTSCHRAUBE  | HEX-BOLT           | VIS 6 PANS         | TORNILLO HEXAGONAL | M14X 95 DIN 931-M 8.8                               |     |
| 38      | 339 1985  | NR         | BEILAGE            | SHIM               | CALE               | SUPLEMENTO         | 1424-17-03-01<br>4 607 MM<br>8285-SIEHE 095.95C-963 |     |



| Bad Nr | Teile-Nr. | Stück-Zahl | Deutsch           | English           | Français           | Español            | Nummer/Bemerkung   | ETK |
|--------|-----------|------------|-------------------|-------------------|--------------------|--------------------|--|-----|
| 42     | 111 8376  | 4          | ZYLINDERSCHRAUBE  | CHEESE-HEAD SCREW | VIS TETE CYLINDR.  | TORN.CBZA.CILIND-  | M 6 X 15DIN 6912- 2-8                                      |     |
| 45     | 111 8681  | 1          | DICHTRING         | WASHER            | BAGUE D ETANCHEITE | ANILLO DE JUNTA    | A 12 X 18 DIN 7603-CU                                      |     |
| 49     | 111 2512  | 1          | SECHSKANTSCHRAUBE | HEX-BOLT          | VIS 6 PANS         | TORNILLO HEXAGONAL | M12X 25 DIN 933-M 2-8                                      |     |
| 50     | 231 1766  | 1          | PASSSTIFT         | DOWEL PIN         | GOUPILLE AJUSTEE   | PERNO AJUSTE       |  |     |
| 51     | 339 2000  | 1          | ZUGSTANGE         | PULLROD           | TIRANT             | BARRA TRACCION     | 1424-16-01-01  |     |
| 52     | 110 6403  | 1          | SPLIT             | SPLIT PIN         | GOUPILLE FENDUE    | PASADOR ALETAS     | 2 X 12DIN 94   |     |
| 53     | 110 7162  | 1          | SCHEIBE           | DISC/PANE/PLATE   | RONDELLE/DISQUE    | DISCO              | 9.5DIN 126   |     |
| 54     | 339 2001  | 1          | TUELLE            | GROMMET           | DOUILLE            | FUNDA              | 1424-16-01-04  |     |
| 950    | 339 1986  | NB         | BEILAGE           | SHIM              | CALE               | SUPLEMENTO         | 1424-17-03-02<br>A 6.3                                     |     |
| 951    | 339 1987  | NB         | BEILAGE           | SHIM              | CALE               | SUPLEMENTO         | 1424-17-03-03<br>A 6.4                                     |     |
| 952    | 339 1988  | NB         | BEILAGE           | SHIM              | CALE               | SUPLEMENTO         | 1424-17-03-04<br>A 6.5                                     |     |
| 953    | 339 1989  | NB         | BEILAGE           | SHIM              | CALE               | SUPLEMENTO         | 1424-17-03-05<br>A 6.6                                     |     |
| 954    | 339 1990  | NB         | BEILAGE           | SHIM              | CALE               | SUPLEMENTO         | 1424-17-03-06<br>A 6.7                                     |     |
| 955    | 339 1991  | NB         | BEILAGE           | SHIM              | CALE               | SUPLEMENTO         | 1424-17-03-07<br>A 6.8                                     |     |
| 956    | 339 1992  | NB         | BEILAGE           | SHIM              | CALE               | SUPLEMENTO         | 1424-17-03-08<br>A 6.9                                     |     |
| 957    | 339 1993  | NB         | BEILAGE           | SHIM              | CALE               | SUPLEMENTO         | 1424-17-03-09<br>A 7                                       |     |
| 958    | 339 1995  | NB         | BEILAGE           | SHIM              | CALE               | SUPLEMENTO         | 1424-17-03-11<br>A 7.1                                     |     |
| 959    | 339 1996  | NB         | BEILAGE           | SHIM              | CALE               | SUPLEMENTO         | 1424-17-03-12<br>A 7.2                                     |     |
| 960    | 339 1997  | NB         | BEILAGE           | SHIM              | CALE               | SUPLEMENTO         | 1424-17-03-13<br>A 7.3                                     |     |
| 961    | 339 1998  | NB         | BEILAGE           | SHIM              | CALE               | SUPLEMENTO         | 1424-17-03-14<br>A 7.4                                     |     |
| 962    | 339 1999  | NB         | BEILAGE           | SHIM              | CALE               | SUPLEMENTO         | 1424-17-03-15<br>A 7.5                                     |     |
| 963    | 339 1985  | SZ         | BEILAGE           | SHIM              | CALE               | SUPLEMENTO         | 1424-17-03-10<br>8076-FINZELTEILE SIEHE POS.<br>38*950-962 |     |

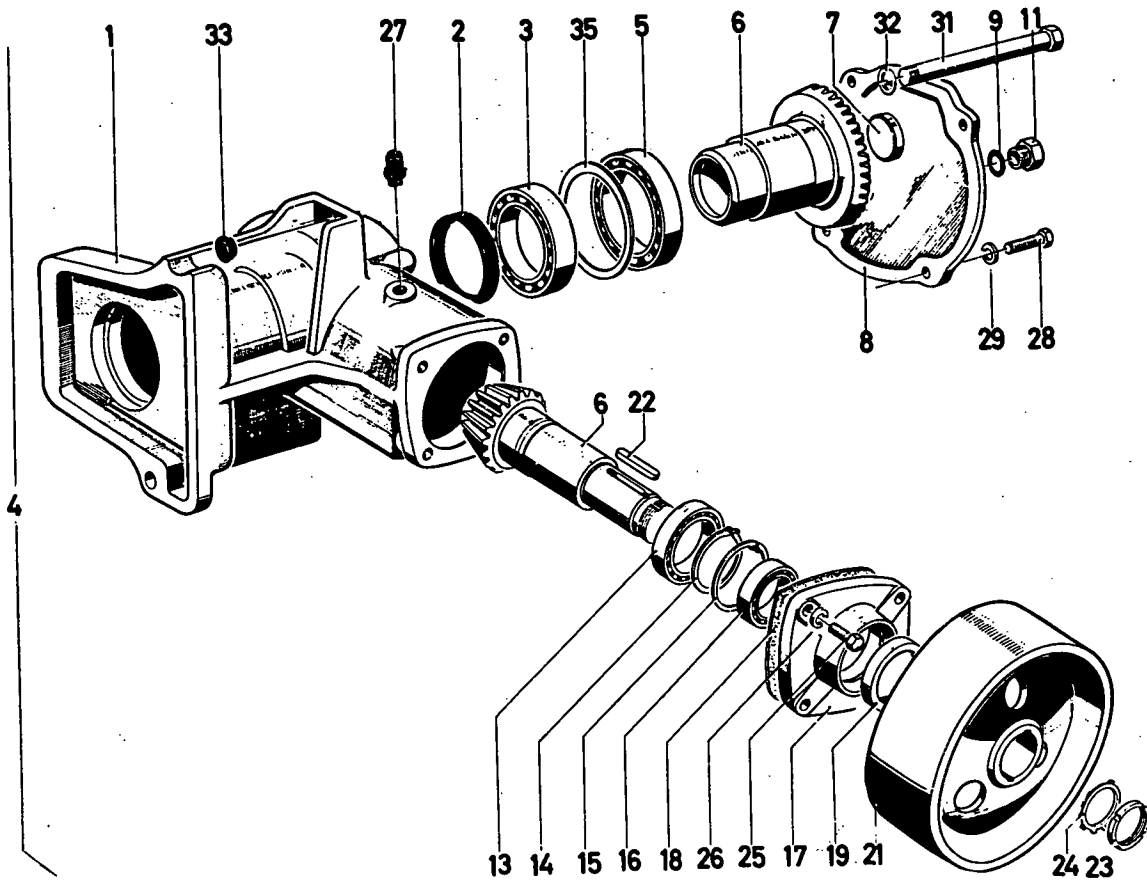

1424-19 500 5116

| Bild Nr. | Teile-Nr. | Stück-Zahl | Deutsch            | English           | Français           | Español            | Nummer/Bemerkung                   | ETK |
|----------|-----------|------------|--------------------|-------------------|--------------------|--------------------|------------------------------------|-----|
| 1        | 339 2002  | 1          | GEHÄUSE            | HOUSING/CASE      | CARTER/BOITIER     | CAJA/BLOQUE/CUERPO | 1424-19-01-03                      |     |
| 2        | 116 0678  | 1          | WELLENDICHTRING    | SHAFT SEAL        | JOINT D ARBRE      | ANILLO HERMET-EJE  | A 45X 68 X10 H 2940-NI             | 01  |
| 3        | 110 8981  | 1          | RILLENKUGELLAGER   | BALL BEARING      | ROUL RAINURE BILLE | COJ-BOLAS FIJO     | 6009 DIN 625                       | 01  |
| 4        | 339 2004  | 1          | ANTRIEB            | DRIVE             | COMMANDE           | ACCIONAMIENTO      | 1424-19-01-10<br>8337-VOLLSTAENDIG |     |
| 5        | 110 9072  | 1          | RILLENKUGELLAGER   | BALL BEARING      | ROUL RAINURE BILLE | COJ-BOLAS FIJO     | 6210 DIN 625                       | 01  |
| 6        | 231 6783  | 1          | KEGELTRIEB         | BEVEL DRIVE       | COUPLE CONIQUE     | GRUPO CÓNICO       | 1424-19-01-30                      |     |
| 7        | 116 5836  | 1          | KERNLOCHVERSCHLUSS | CORE HOLE PLUG    | BOUCHON TROU DESS  | CIERRE MACHO       | 840 1 711                          |     |
| 8        | 339 0433  | 1          | BECKEL             | COVER             | COUVERCLE          | TAPA               | 1155-19-07-06                      |     |
| 9        | 111 8713  | 1          | DICHTRING          | WASHER            | BAGUE D ETANCHEITE | ANILLO DE JUNTA    | A 18 X 22 DIN 7603-CU              |     |
| 11       | 111 8970  | 1          | VERSCHLUSSSCHRAUBE | SCREW PLUG        | BOUCHON FILETE     | TAPON ROSCADO      | M18X1,5 DIN 7604                   |     |
| 13       | 110 9129  | 1          | RILLENKUGELLAGER   | BALL BEARING      | ROUL RAINURE BILLE | COJ-BOLAS FIJO     | 6307 DIN 625                       | 01  |
| 14       | 110 7748  | 1          | SICHERUNGSRING     | CIRCLIP           | CIRCLIP            | CIRCLIP            | 35X1,5 DIN 471                     |     |
| 15       | 110 7844  | 1          | SICHERUNGSRING     | CIRCLIP           | CIRCLIP            | CIRCLIP            | 62X2 DIN 472                       |     |
| 16       | 110 9121  | 1          | RILLENKUGELLAGER   | BALL BEARING      | ROUL RAINURE BILLE | COJ-BOLAS FIJO     | 6305 DIN 625                       | 01  |
| 17       | 339 0419  | 1          | LAGERDECKEL        | BEARING CAP       | CHAPEAU DE PALIER  | TAPA SOPORTE       | 1155-19-01-02                      |     |
| 18       | 339 0427  | SZ         | BEILAGE            | SHIM              | CALE               | SUPLEMENTO         | 1155-19-02-10                      |     |
| 19       | 116 0770  | 1          | WELLENDICHTRING    | SHAFT SEAL        | JOINT D ARBRE      | ANILLO HERMET-EJE  | A 40X 62 X12 H 2940-NI             | 01  |
| 21       | 339 2007  | 1          | RIEMENSCHLEIBE     | BELT PULLEY       | POULIE A COURROIE  | POLEA CORREA       | 1424-19-01-23                      |     |
| 22       | 111 8015  | 2          | PASSFEDER          | KEY               | CLAVETTE ENCASTREE | LENGUETA AJUSTE    | A 8X 5X 36 DIN 6885                |     |
| 23       | 116 7158  | 1          | NUTMUTTER          | GROOVED NUT       | ECROU RAINURE      | TUERCA RANURADA    | M 24X1,5H 2174                     |     |
| 24       | 112 0660  | 1          | SICHERUNGSBLECH    | LOCKING PLATE     | TOLE DE SECURITE   | CHAPA SEGURIDAD    | A 24DIN73952                       |     |
| 25       | 111 2333  | 4          | SECHSKANTSCHRAUBE  | HEX-BOLT          | VIS 6 PANS         | TORNILLO HEXAGONAL | M 8X 25 DIN 933- 8.8-A4C           |     |
| 26       | 110 2799  | 4          | FEDERRING          | SPRING LOCKWASHER | RONDELLE GROWER    | ARANDELA ELASTICA  | A 8 DIN 128 A4C                    |     |
| 27       | 339 0428  | 1          | ENTLUEFTUNGSVENTIL | BREATHER VALVE    | SOUP DEGAGEN D AIR | VALV-PRGA-AIRE     | 1155-19-03-10                      |     |
| 28       | 111 2258  | 4          | SECHSKANTSCHRAUBE  | HEX-BOLT          | VIS 6 PANS         | TORNILLO HEXAGONAL | M 6X 18 DIN 933- 8.8-A4C           |     |

| Bld<br>Nr. | Teil-Nr. | Stück-<br>Zahl | Deutsch           | English           | Français         | Español            | Nummer/Bemerkung  | ETK |
|------------|----------|----------------|-------------------|-------------------|------------------|--------------------|---|-----|
| 29         | 110 2797 | 4              | FEDERRING         | SPRING LOCKWASHER | RONDELLE GROMER  | ARANDELA ELASTICA  | A 6 DIN 328 A4C   |     |
| 31         | 111 1960 | 2              | SECHSKANTSCHRAUBE | HEX-BOLT          | VIS 6 PANS       | TORNILLO HEXAGONAL | M16X 160 DIN 933-M 6-8 A4C                              |     |
| 32         | 110 7557 | 2              | SCHÉIBE           | DISC/PANE/PLATE   | RONDELLE/DISQUE  | DISCO              | 17 DIN 933-S7   |     |
| 33         | 116 5997 | 2              | RUNDGUMMIRING     | O-SEAL            | ANNEAU TORIQUE   | ANILLO GOMA REDOND | 12 X 4 H 721  | 01  |
| 35         | 339 0425 | NB             | PASSRING          | SHIM              | BAGUE D AJUSTAGE | ANILLO AJUSTE      | 1155-19-01-08<br>A 5.3 MM<br>B355-MAHLWEISE POS-950-956 |     |
| 950        | 339 2009 | NB             | PASSRING          | SHIM              | BAGUE D AJUSTAGE | ANILLO AJUSTE      | 1424-19-02-02<br>A 5.4MM                                |     |
| 951        | 339 2010 | NB             | PASSRING          | SHIM              | BAGUE D AJUSTAGE | ANILLO AJUSTE      | 1424-19-02-03<br>A 5.5MM                                |     |
| 952        | 339 2011 | NB             | PASSRING          | SHIM              | BAGUE D AJUSTAGE | ANILLO AJUSTE      | 1424-19-02-04<br>A 5.6MM                                |     |
| 953        | 339 2013 | NB             | PASSRING          | SHIM              | BAGUE D AJUSTAGE | ANILLO AJUSTE      | 1424-19-02-05<br>A 5.7MM                                |     |
| 954        | 339 2015 | NB             | PASSRING          | SHIM              | BAGUE D AJUSTAGE | ANILLO AJUSTE      | 1424-19-02-06<br>A 5.8MM                                |     |
| 955        | 339 2016 | NB             | PASSRING          | SHIM              | BAGUE D AJUSTAGE | ANILLO AJUSTE      | 1424-19-02-07<br>A 5.9MM                                |     |
| 956        | 339 2017 | NB             | PASSRING          | SHIM              | BAGUE D AJUSTAGE | ANILLO AJUSTE      | 1424-19-02-08<br>A 6.0MM                                |     |

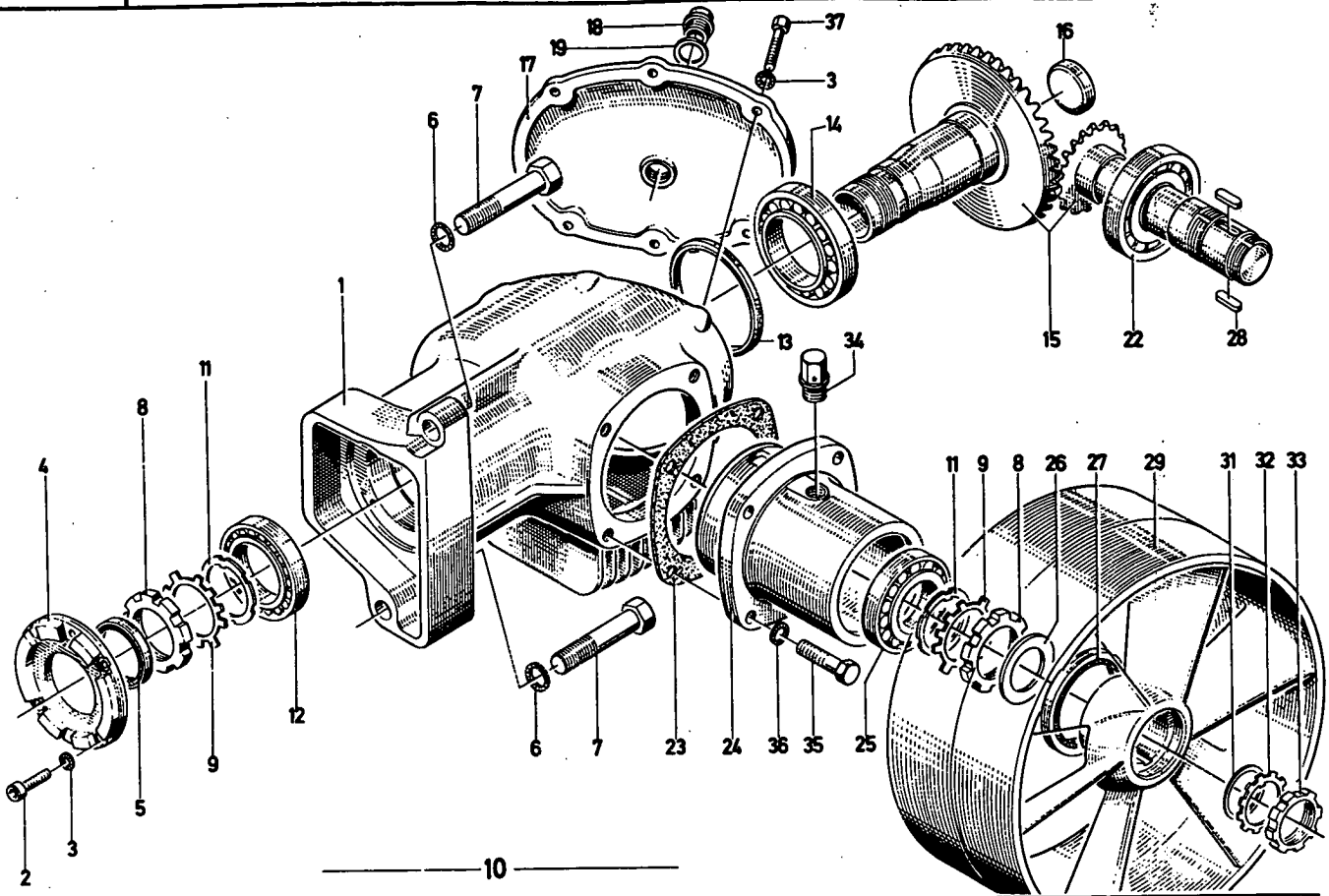

1434-19 500 5115

| Bild Nr. | Teil-Nr. | Stück-Zahl | Deutsch            | English            | Français           | Español            | Nummer/Bemerkung                        | ETK |
|----------|----------|------------|--------------------|--------------------|--------------------|--------------------|---|-----|
| 1        | 339 2271 | 1          | GEHÄUSE            | HOUSING/CASE       | CARTER/BOITIER     | CAJA/BLOQUE/CUERPO | 1434-19-01-01                           |     |
| 2        | 111 0507 | 4          | ZYLINDERSCHRAUBE   | CHEESE-HEAD SCREW  | VIS TETE CYLINDR.  | TORN.CBZA.CILIND.  | M 6X 15DIN 912- 6.9 VZKC                |     |
| 3        | 116 7194 | 10         | SICHERUNGSSCHEIBE  | LOCKING WASHER     | RONDELLE SECURITE  | ARANDELA SEGURIDAD | 6 H 2203                                |     |
| 4        | 339 2273 | 1          | ZENTRIERFLANSCH    | CENTERING FLANGE   | BRIDE DE CENTRAGE  | BRIDA CENTRAJE     | 1434-19-01-04                           |     |
| 5        | 116 9479 | 1          | WELLENDICHTRING    | SHAFT SEAL         | JOINT D ARBRE      | ANILLO HERMET-EJE  | A 42X 55 X 7 H 645                      | 01  |
| 6        | 116 9697 | 2          | SICHERUNGSSCHEIBE  | LOCKING WASHER     | RONDELLE SECURITE  | ARANDELA SEGURIDAD | 16 H 2203                               |     |
| 7        | 111 1888 | 2          | SECHSKANTSCHRAUBE  | HEX-BOLT           | VIS 6 PANS         | TORNILLO HEXAGONAL | M16X 70 DIN 931-M 8-8 A4C               |     |
| 8        | 116 7164 | 2          | NUTMUTTER          | GROOVED NUT        | ECROU RAINURE      | TUERCA RANURADA    | M 45X1.5H 2174                          |     |
| 9        | 339 2275 | 2          | SICHERUNGSBLECH    | LOCKING PLATE      | TOLE DE SECURITE   | CHAPA SEGURIDAD    | 1434-19-01-09                           |     |
| 10       | 339 2276 | 1          | ANTRIEB            | DRIVE              | COMMANDE           | ACCIONAMIENTO      | 1434-19-01-10<br>8337-VOLLSTAENDIG      |     |
| 11       | 339 2277 | 2          | SICHERUNGSBLECH    | LOCKING PLATE      | TOLE DE SECURITE   | CHAPA SEGURIDAD    | 1434-19-01-11                           |     |
| 12       | 116 8683 | 1          | KEGELROLLENLAGER   | TAP-ROLLER BEARING | ROULEM A ROUL CON  | COJ-RODIL-CONICOS  | 45.3X 77.8X19.8 H 4450                  | 01  |
| 13       | 231 6994 | 1          | ABSTANDRING        | SPACER RING        | BAGUE ECARTEMENT   | ARO DISTANCIARIO   | 1434-19-02-10<br>8076-SIEHE POS.950-954 |     |
| 14       | 116 8684 | 1          | KEGELROLLENLAGER   | TAP-ROLLER BEARING | ROULEM A ROUL CON  | COJ-RODIL-CONICOS  | 57.5X 96.8X23 H 4450                    | 01  |
| 15       | 339 2282 | 1          | KEGELRAD           | BEVEL GEAR         | ENGREN CONIQUE     | RUEDA CONICA       | 1434-19-01-20                           |     |
| 16       | 116 5836 | 1          | KERNLOCHVERSCHLUSS | CORE HOLE PLUG     | BOUCHON TROU DESS  | CIERRE MACHO       | 840 4 711                               |     |
| 17       | 339 2280 | 1          | DECKEL             | COVER              | COUVERCLE          | TAPA               | 1434-19-01-17                           |     |
| 18       | 111 8971 | 1          | VERSCHLUSSSCHRAUBE | SCREW PLUG         | BOUCHON FILETE     | TAPON ROSCADO      | M18X1.5 DIN 7604 VZKC                   |     |
| 19       | 111 8713 | 1          | DICHTRING          | WASHER             | BAGUE D ETANCHEITE | ANILLO DE JUNTA    | A 18 X 22 DIN 7603-CU                   |     |
| 22       | 116 8682 | 1          | KEGELROLLENLAGER   | TAP-ROLLER BEARING | POULEM A ROUL CON  | COJ-RODIL-CONICOS  | 44.5X 85.9X23.8 H 4450                  | 01  |
| 23       | 339 2304 | 1          | BEILAGE            | SHIM               | CALE               | SUPLEMENTO         | 1434-19-03-10                           |     |
| 24       | 339 2285 | 1          | FLANSCHGEHÄUSE     | FLANGE HOUSING     | BOITE A BRIDE      | CAJA BRIDA         | 1434-19-01-24                           |     |
| 25       | 116 8681 | 1          | KEGELROLLENLAGER   | TAP-ROLLER BEARING | ROULEM A ROUL CON  | COJ-RODIL-CONICOS  | 44.5X 82.9X23.8 H 4450                  | 01  |
| 26       | 339 2287 | 1          | DICHTSCHEIBE       | SEALING WASHER     | RONDELLE D ETANCH  | ARANDELA HERMETIZ- | 1434-19-01-26                           | 01  |
| 27       | 116 5286 | 1          | WELLENDICHTRING    | SHAFT SEAL         | JOINT D ARBRE      | ANILLO HERMET-EJE  | A 65X 85 X10 H 645                      | 01  |

| Bld Nr. | Teile-Nr. | Stück-Zahl | Deutsch            | English         | Français            | Español            | Nummer/Bemerkung          | ETK |
|---------|-----------|------------|--------------------|-----------------|---------------------|--------------------|---------------------------|-----|
| 28      | 111 8098  | 2          | PASSFEDER          | KEY             | CLAVETTE ENCASTREE  | LENGUETA AJUSTE    | A12X 8X 36 DIN 6885       |     |
| 29      | 339 2288  | 1          | RIEMENSCHLEIBE     | BELT PULLEY     | POULIE A COURROIE   | POLEA CORREA       | 1434-19-01-29             |     |
| 31      | 116 7261  | 1          | SCHLEIBE           | DISC/PANE/PLATE | RONDELLE/DISQUE     | DISCO              | 35 X54X2 H 2308           |     |
| 32      | 121 6055  | 1          | SICHERUNGSBLECH    | LOCKING PLATE   | TOLE DE SECURITE    | CHAPA SEGURIDAD    | 2 250 C 1                 |     |
| 33      | 116 7161  | 1          | NUTMUTTER          | GROOVED NUT     | ECROU RAINURE       | TUERCA RAMURADA    | M 35X1.5H 2174            |     |
| 34      | 339 0428  | 1          | ENTLUEFTUNGSVENTIL | BREATHER VALVE  | SOUP DEGAGEMENT AIR | VALV. PRGA-AIRE    | 1155-19-03-10             |     |
| 35      | 111 2538  | 4          | SECHSKANTSCHRAUBE  | HEX-BOLT        | VIS 6 PANS          | TORNILLO HEXAGONAL | M12X 35 DIN 933-M 8-8-A4C |     |
| 36      | 116 9695  | 4          | SICHERUNGSSCHLEIBE | LOCKING WASHER  | RONDELLE SECURITE   | ARANDELA SEGURIDAD | 12 H 2203                 |     |
| 37      | 111 2251  | 6          | SECHSKANTSCHRAUBE  | HEX-BOLT        | VIS 6 PANS          | TORNILLO HEXAGONAL | M 6X 15 DIN 933- 8-8-A4C  |     |
| 950     | 339 2292  | NB         | ABSTANDRING        | SPACER RING     | BAGUE ECARTEMENT    | ARO DISTANCIARIO   | 1434-19-02-03<br>A 6.5 MM |     |
| 951     | 339 2293  | NB         | ABSTANDRING        | SPACER RING     | BAGUE ECARTEMENT    | ARO DISTANCIARIO   | 1434-19-02-04<br>A 6.7 MM |     |
| 952     | 339 2294  | NB         | ABSTANDRING        | SPACER RING     | BAGUE ECARTEMENT    | ARO DISTANCIARIO   | 1434-19-02-05<br>A 6.5 MM |     |
| 953     | 339 2295  | NB         | ABSTANDRING        | SPACER RING     | BAGUE ECARTEMENT    | ARO DISTANCIARIO   | 1434-19-02-06<br>A 6.7 MM |     |
| 954     | 339 2296  | NB         | ABSTANDRING        | SPACER RING     | BAGUE ECARTEMENT    | ARO DISTANCIARIO   | 1434-19-02-07<br>A 7.3 MM |     |

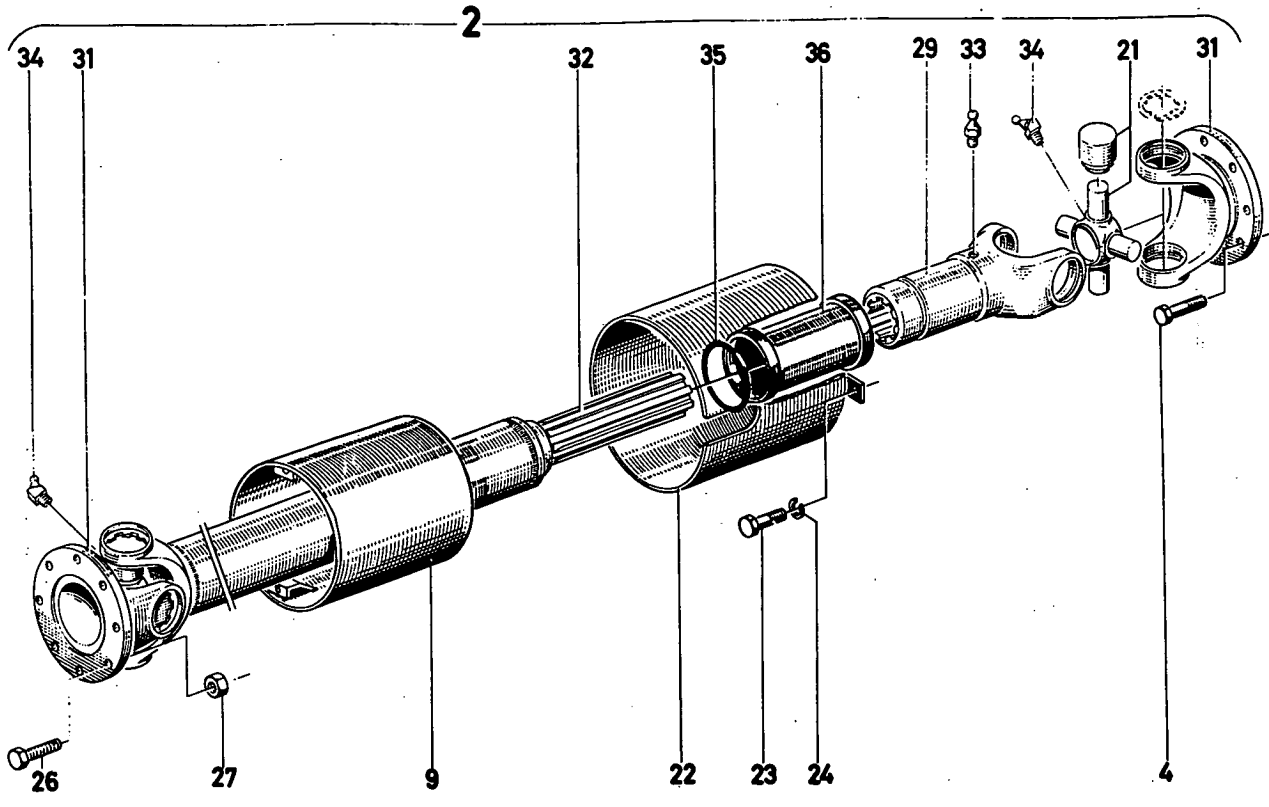

1005-21 500 5117

| Bild Nr. | Teile-Nr. | Stück-Zahl | Deutsch            | English           | Français           | Español            | Nummer/Bemerkung            | ETK |
|----------|-----------|------------|--------------------|-------------------|--------------------|--------------------|-----------------------------|-----|
| 2        | 230 9759  | 1          | GELENKWELLE        | JOINT SHAFT       | ARBRE A CARDAN     | EJE ARTICULADO     |                             |     |
| 4        | 111 2314  | 6          | SECHSKANTSCHRAUBE  | HEX-BOLT          | VIS 6 PANS         | TORNILLO HEXAGONAL | M 8X 1,8 SKDIN 933- 8-8-A4C |     |
| 9        | 231 5612  | 1          | GELENKWELLENSCHUTZ | SHAFT PROTECTION  | GARDE ARBRE CARDAN | PROTECT-CARDAN     | 8346-VORN                   |     |
| 21       | 238 6548  | 2          | GELENKKREUZ        | UNIVERSAL JOINT   | CROISILLON DE JT   | CRUCETA ARTICUL.   | 8337-VOLLSTAENDIG           |     |
| 22       | 232 5568  | 1          | GELENKWELLENSCHUTZ | SHAFT PROTECTION  | GARDE ARBRE CARDAN | PROTECT-CARDAN     | 8150-MINTEN                 |     |
| 23       | 111 2240  | 3          | SECHSKANTSCHRAUBE  | HEX-BOLT          | VIS 6 PANS         | TORNILLO HEXAGONAL | M 6X 1,2 DIN 933- 8-8-A4C   |     |
| 24       | 110 2797  | 3          | FEDERRING          | SPRING LOCKWASHER | RONDELLE GROMER    | ARANDELA ELASTICA  | A 6 DIN 128 A4C             |     |
| 26       | 232 6052  | 6          | SECHSKANTSCHRAUBE  | HEX-BOLT          | VIS 6 PANS         | TORNILLO HEXAGONAL |                             |     |
| 27       | 110 0507  | 6          | SECHSKANTHUTTER    | HEX-NUT           | ECROU 6 PANS       | TUERCA HEXAGONAL   | M 8X1 DIN 985- 8 A4C        |     |
| 29       | 230 6850  | 1          | GELENK             | JOINT/HINGE       | JOINT/ARTICULATION | ARTICULAC-         |                             |     |
| 31       | 230 6852  | 2          | GELENKFLANSCH      | JOINT FLANGE      | FLASQUE D ARTICUL  | BRIDA ARTICULAC-   |                             |     |
| 32       | 238 1184  | 1          | NABENGELENK        | HUB JOINT         | ARTICULATION MOYEU | ARTICULACION CUBO  |                             |     |
| 33       | 112 0674  | 1          | KEGELSCHMIERNIPPEL | LUBE FITTING      | GRAISSEUR CONIQUE  | ENGRASADOR CONICO  | AM10X1 DIN71412             |     |
| 34       | 112 0700  | 2          | KEGELSCHMIERNIPPEL | LUBE FITTING      | GRAISSEUR CONIQUE  | ENGRASADOR CONICO  | CM 8X1 DIN71412             |     |
| 35       | 230 6856  | 1          | PROFILSCHUTZ       | SECTION GUARD     | PATIN DE GARDE     | PROTECC-PERFIL     |                             |     |
| 36       | 238 6976  | 1          | WELLENSCHUTZHUELSE | SHAFT SLEEVE      | GAINÉ PROTECTRICE  | CASQ-PROTEC-EJE    |                             |     |

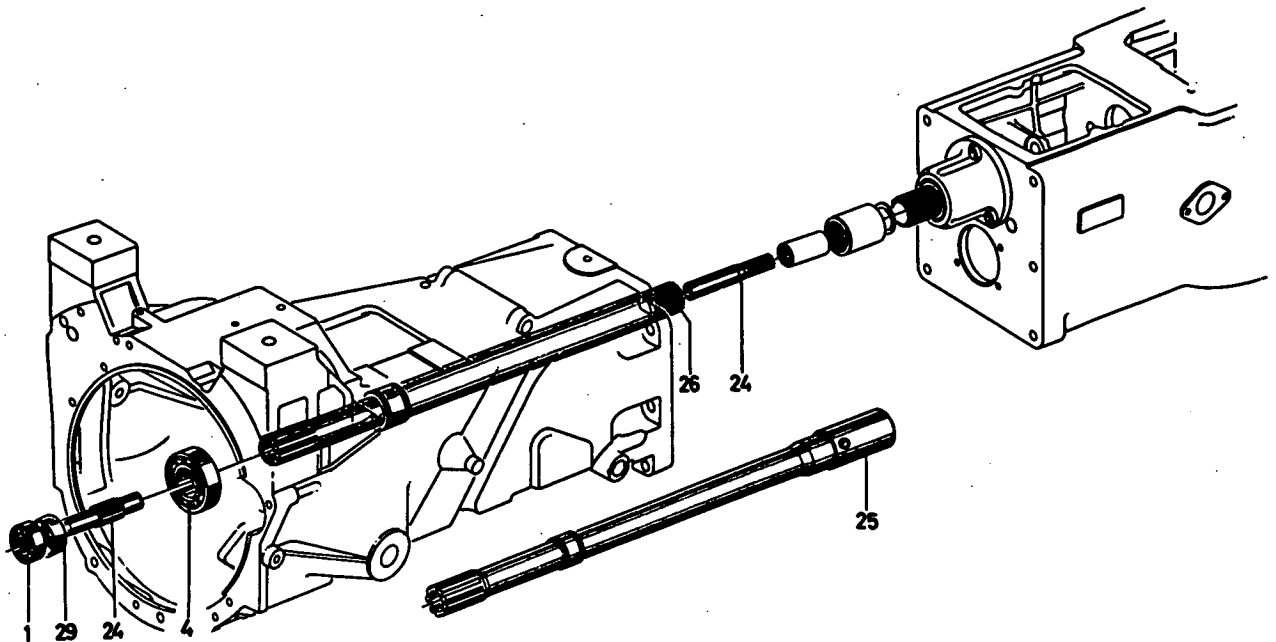

9

1003-22 500 4198

| Bild Nr. | Teil-Nr. | Stück-Zahl | Deutsch          | English      | Français           | Español        | Nummer/Bemerkung  | ETK |
|----------|----------|------------|------------------|--------------|--------------------|----------------|-------------------|-----|
| 1        | 113 6432 | 1          | WILLENKUGELLAGER | BALL BEARING | ROUL RAINURE BILLE | COJ-BOLAS FIJO | 6304-2RS1 DIN 625 | 01  |
| 4        | 238 5441 | 1          | WILLENKUGELLAGER | BALL BEARING | ROUL RAINURE BILLE | COJ-BOLAS FIJO |                   | 01  |
| 24       | 230 7519 | 1          | ANTRIEBSWELLE    | DRIVE SHAFT  | ARBRE DE COMMANDE  | EJE MOTRIZ     |                   |     |
| 25       | 231 1404 | 1          | ANTRIEBSWELLE    | DRIVE SHAFT  | ARBRE DE COMMANDE  | EJE MOTRIZ     | SY.               |     |
| 26       | 231 1360 | 1          | ANTRIEBSWELLE    | DRIVE SHAFT  | ARBRE DE COMMANDE  | EJE MOTRIZ     |                   |     |
| 27       | 238 5450 | 1          | BUNDRING         | COLLAR RING  | BAGUE A COLLET     | ARO COLLARIN   |                   |     |

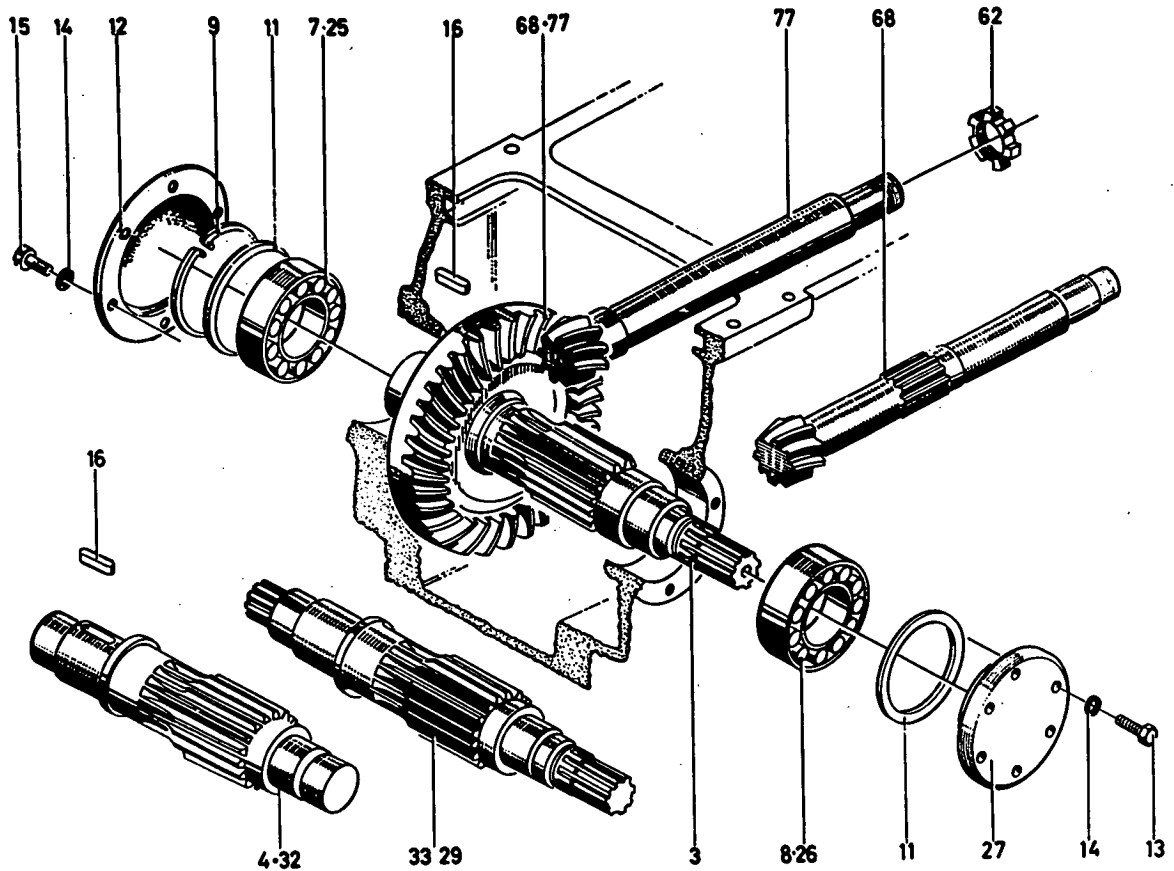

1435-23 500 4199

| Bld Nr. | Teil-Nr. | Stück-Zahl | Deutsch           | English            | Français           | Español            | Nummer/Bemerkung                                    | ETK |
|---------|----------|------------|-------------------|--------------------|--------------------|--------------------|---|-----|
| 3       | 339 2354 | 1          | ZWISCHENWELLE     | INTERMEDIATE SHAFT | ARBRE INTERN.      | EJE INTERMEDIO     | 1435-23-01.03<br>Z 61 13 TW 35-1<br>8190.LANG       |     |
| 4       | 339 2355 | 1          | ZWISCHENWELLE     | INTERMEDIATE SHAFT | ARBRE INTERN.      | EJE INTERMEDIO     | 1435-23-01.04<br>Z 61 13 TW 35-1<br>8182.KURZ       |     |
| 7       | 110 1386 | 1          | KEGELROLLENLAGER  | TAP-ROLLER BEARING | ROULEM A ROUL CON  | COJ-RODIL-CONICOS  | 30311A DIN 720<br>8355.WAHLWEISE POS-25             | 01  |
| 8       | 110 1339 | 1          | KEGELROLLENLAGER  | TAP-ROLLER BEARING | ROULEM A ROUL CON  | COJ-RODIL-CONICOS  | 32311A DIN 720<br>8355.WAHLWEISE POS-26             | 01  |
| 9       | 110 7863 | 1          | SICHERUNGSRING    | CIRCLIP            | CIRCLIP            | CIRCLIP            | 110X4 DIN 472                                       |     |
| 11      | 339 2503 | NB         | BEILAGE           | SHIM               | CALE               | SUPLEMENTO         | 1445-23-21.03<br>A 20 MM.<br>8285.SICHE POS-950-956 |     |
| 12      | 339 2494 | 1          | DECKEL            | COVER              | COUVERCLE          | TAPA               | 1445-23-01.05                                       |     |
| 13      | 111 2326 | 6          | SECHSKANTSCHRAUBE | HEX-BOLT           | VIS 6 PANS         | TORNILLO HEXAGONAL | M 8X 22 DIN 933- 8.8-A4C                            |     |
| 14      | 116 9689 | 11         | SICHERUNGSSCHEIBE | LOCKING WASHER     | RONDILLE SECURITE  | ARANDELA SEGURIDAD | 8 H 2203  |     |
| 15      | 111 2299 | 5          | SECHSKANTSCHRAUBE | HEX-BOLT           | VIS 6 PANS         | TORNILLO HEXAGONAL | M 8X 12 DIN 933- 8.8-A4C                            |     |
| 16      | 111 8157 | 2          | PASSFEDER         | KEY                | CLAVETTE ENCASTREE | LENGUETA AJUSTE    | A16X10X 60 DIN 6885                                 |     |
| 25      | 110 1384 | 1          | KEGELROLLENLAGER  | TAP-ROLLER BEARING | ROULEM A ROUL CON  | COJ-RODIL-CONICOS  | 30311J2DIN 720<br>8355.WAHLWEISE POS-7              | 01  |
| 26      | 110 1340 | 1          | KEGELROLLENLAGER  | TAP-ROLLER BEARING | ROULEM A ROUL CON  | COJ-RODIL-CONICOS  | 32311J2DIN 720<br>8355.WAHLWEISE POS-8              | 01  |
| 27      | 339 2497 | 1          | DECKEL            | COVER              | COUVERCLE          | TAPA               | 1445-23-01.14                                       |     |
| 29      | 230 6932 | 1          | ZWISCHENWELLE     | INTERMEDIATE SHAFT | ARBRE INTERN.      | EJE INTERMEDIO     | Z 61 13 TW 35-1 A<br>8190.LANG                      |     |
| 32      | 233 3955 | 1          | ZWISCHENWELLE     | INTERMEDIATE SHAFT | ARBRE INTERN.      | EJE INTFMEDIO      | Z 62 12.TW 35-4                                     |     |
| 33      | 233 5278 | 1          | ZWISCHENWELLE     | INTERMEDIATE SHAFT | ARBRE INTERN.      | EJE INTERMEDIO     | Z 62 12.TW 35.4 A                                   |     |
| 62      | 121 6035 | 1          | NUTMUTTER         | GROOVED NUT        | ECROU RAINURE      | TUERCA RANURADA    | 2 174 B 35  |     |
| 68      | 232 9620 | 1          | KEGELTRIEB        | BEVEL DRIVE        | COUPLE CONIQUE     | GRUPO CONICO       | Z 34 7 VAR-S TW 35-3/4<br>8297.SYNCHRON             |     |



| Bild<br>Nr. | Teil-Nr. | Stück-<br>Zahl | Deutsch    | English     | Français       | Español      | Nummer/Bemerkung       | ETK |
|-------------|----------|----------------|------------|-------------|----------------|--------------|------------------------|-----|
| 77          | 233 4695 | 1              | KEGELTRIEB | BEVEL DRIVE | COUPLE CONIQUE | GRUPO CONICO | Z 33 7.28.35.2         |     |
| 950         | 339 2504 | NB             | BEILAGE    | SHIM        | CALE           | SUPLENTO     | 1445-23-21.02<br>A 2.1 |     |
| 951         | 339 2505 | NB             | BEILAGE    | SHIM        | CALE           | SUPLENTO     | 1445-23-21.03<br>A 2.2 |     |
| 952         | 339 2506 | NB             | BEILAGE    | SHIM        | CALE           | SUPLENTO     | 1445-23-21.04<br>A 2.3 |     |
| 953         | 339 2508 | NB             | BEILAGE    | SHIM        | CALE           | SUPLENTO     | 1445-23-21.06<br>A 2.5 |     |
| 954         | 339 2511 | NB             | BEILAGE    | SHIM        | CALE           | SUPLENTO     | 1445-23-21.09<br>A 2.8 |     |
| 955         | 339 2513 | NB             | BEILAGE    | SHIM        | CALE           | SUPLENTO     | 1445-23-21.12<br>A 3.0 |     |
| 956         | 339 2522 | NB             | BEILAGE    | SHIM        | CALE           | SUPLENTO     | 1445-23-21.39<br>A 5.5 |     |



AUSGLEICHGETRIEBE  
DIFFERENTIAL UNIT  
DIFFERENTIAL  
DIFERENCIAL

1435-24 500 5350

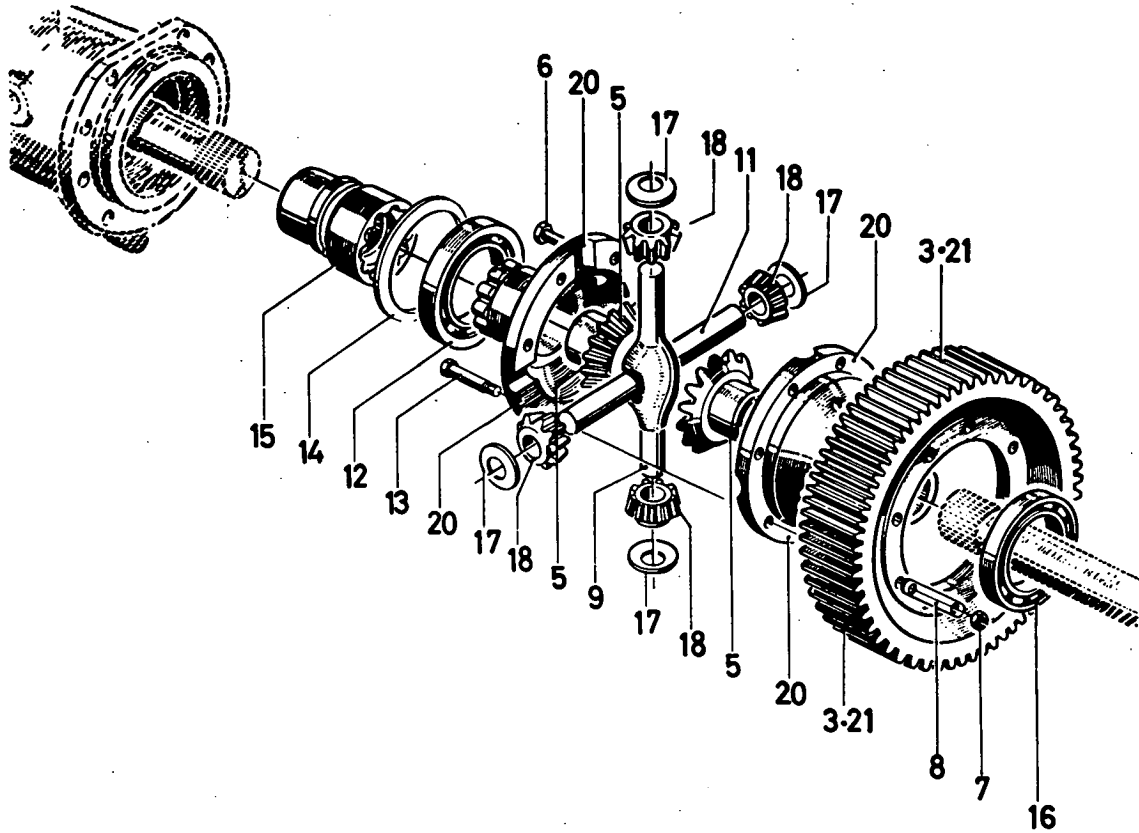

| Bd<br>Nr. | Teil-Nr. | Stück-<br>Zahl | Deutsch           | English          | Français           | Español            | 1435-24 500 5350<br>Nummer/Bemerkung | ETK |
|-----------|----------|----------------|-------------------|------------------|--------------------|--------------------|--------------------------------------|-----|
| 3         | 339 2361 | 1              | ZAHNRAD           | GEAR             | ROUE DENTÉE        | RUEDA DENTADA      | 1435-24-01-16<br>Z 61                |     |
| 5         | 339 2325 | 2              | KEGELRAD          | BEVEL GEAR       | ENGREN CONIQUE     | RUEDA CONICA       | Z 16                                 |     |
| 6         | 111 1499 | 4              | SECHSKANTSCHRAUBE | HEX-BOLT         | VIS 6 PANS         | TORNILLO HEXAGONAL | M12X 60 DIN 931-M10.9                |     |
| 7         | 111 2861 | 12             | SECHSKANTRUTTER   | HEX-NUT          | ECROU 6 PANS       | TUERCA HEXAGONAL   | M12 DIN 934-M10                      |     |
| 8         | 339 2340 | 6              | SICHERUNGSBLECH   | LOCKING PLATE    | TOLE DE SECURITE   | CHAPA SEGURIDAD    |                                      |     |
| 9         | 339 2336 | 1              | KREUZZAPPEN       | SPIDER           | TENON EN CROIX     | MUNON CRUCETA      | 1434-24-02-04                        |     |
| 11        | 339 2341 | 1              | KREUZZAPPEN       | SPIDER           | TENON EN CROIX     | MUNON CRUCETA      |                                      |     |
| 12        | 110 9001 | 1              | RILLENKUGELLAGER  | BALL BEARING     | ROUL RAINURE BILLE | COJ-BOLAS FIJO     | 6017 DIN 625                         | 01  |
| 13        | 121 5909 | 6              | PASSSCHRAUBE      | FITTED BOLT      | VIS D AJUSTAGE     | TORN-VAST-CALIBRAD | 2 010 A 7                            |     |
| 14        | 339 2069 | 1              | SCHIEBE           | DISC/PANE/PLATE  | RONDELLE/DISQUE    | DISCO              | 1424-24-02-13                        |     |
| 15        | 339 2345 | 1              | KUPPLUNGSMUFFE    | CLUTCH SLEEVE    | MANCHON COUPLEUR   | MANGUITO ACOPLAM.  | 1434-25-01-01                        |     |
| 16        | 111 7131 | 1              | ZYL.-ROLLENLAGER  | PAR-ROLL-BEARING | ROULER. ROUL-CYL.  | COJ-RODILL-CILINDR | NJ 1015 DIN 5412                     | 01  |
| 17        | 339 2366 | 4              | ANLAUFSCHIEBE     | STOP WASHER      | DISQUE BUTEE       | ARANDELA TOPE      |                                      |     |
| 18        | 339 2365 | 4              | KEGELRAD          | BEVEL GEAR       | ENGREN CONIQUE     | RUEDA CONICA       | Z 9                                  |     |
| 20        | 339 2343 | 1              | DIFFER-GEHAUSE    | DIFF-CASE        | CARTER DU DIFFER   | CAJA DIFERENCIAL   | 1434-24-02-50                        |     |
| 21        | 233 3757 | 1              | ZAHNRAD           | GEAR             | ROUE DENTÉE        | RUEDA DENTADA      | Z 62                                 |     |

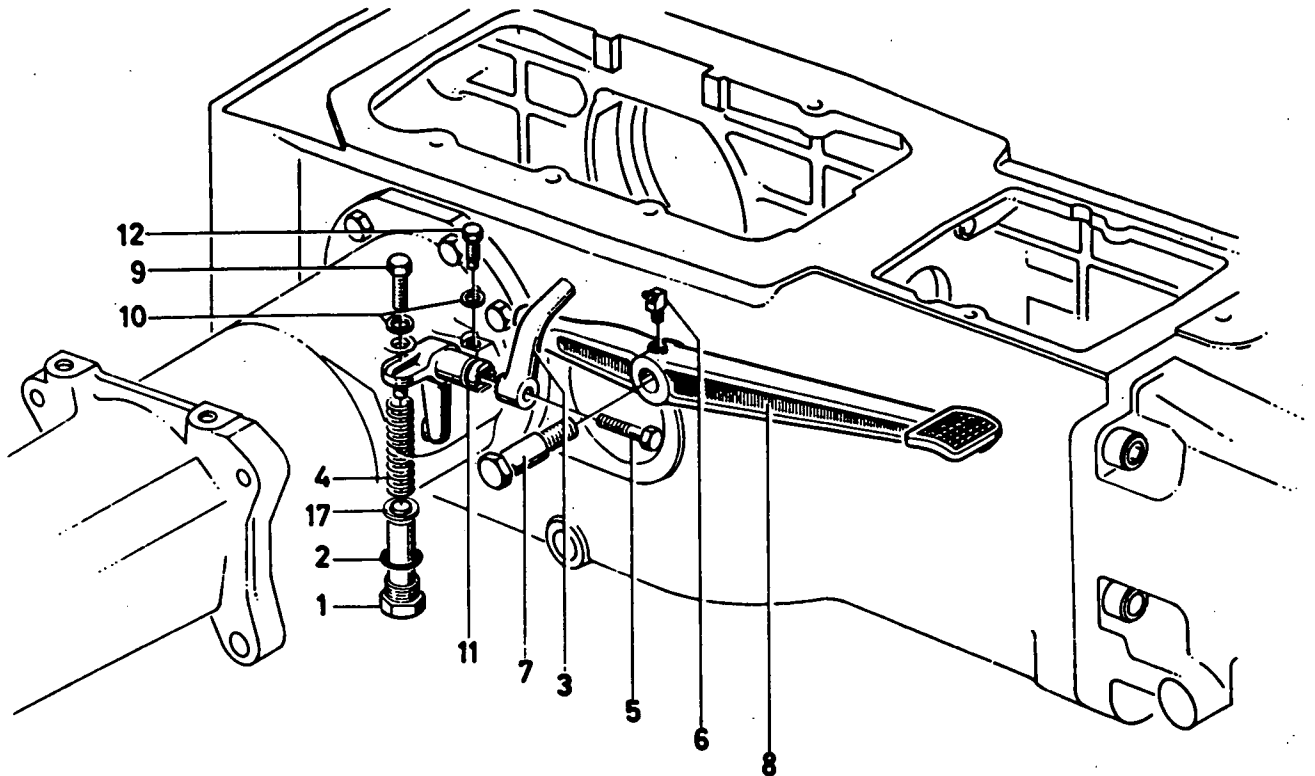

1445-25 500 3072

| Bld. Nr. | Teile-Nr. | Stück-Zahl | Deutsch           | English         | Français           | Español            | Nummer/Bemerkung      | ETK |
|----------|-----------|------------|-------------------|-----------------|--------------------|--------------------|-----------------------|-----|
| 1        | 339 2590  | 1          | SECHSKANTSCHRAUBE | HEX-BOLT        | VIS 6 PANS         | TORNILLO HEXAGONAL | 1445-25-01-02         |     |
| 2        | 111 8737  | 1          | DICHTRING         | WASHER          | BAGUE D ETANCHEITE | ANILLO DE JUNTA    | A 22 X 27 DIN 7603-CU |     |
| 3        | 347 1122  | 1          | UMLENKHEBEL       | REVERSING LEVER | LEVIER DE RENVOI   | PALANCA INVERSION  | 1445-25-02-03         |     |
| 4        | 338 7604  | 1          | SCHRAUBENFEDER    | HELICAL SPRING  | RESSORT A BOUDIN   | RESORTE HELICOIDAL | 1124-25-01-05         | 01  |
| 5        | 111 2427  | 1          | SECHSKANTSCHRAUBE | HEX-BOLT        | VIS 6 PANS         | TORNILLO HEXAGONAL | M10X 30 DIN 933- 8-8  |     |
| 6        | 116 8227  | 1          | SCHMIERNIPPEL     | LUBE FITTING    | RACCORD GRAISSEUR  | NIPLE LUBRICACION  | S8 84.3360            |     |
| 7        | 347 1123  | 1          | LAGERBOLZEN       | PIVOT PIN       | AXE SUPPORT        | BULON SOPORTE      | 1445-25-02-08         |     |
| 8        | 232 1974  | 1          | HEBEL             | LEVER/ARM       | LEVIER             | PALANCA            |                       |     |
| 9        | 111 2320  | 1          | SECHSKANTSCHRAUBE | HEX-BOLT        | VIS 6 PANS         | TORNILLO HEXAGONAL | M 8X 20 DIN 933- 8-8  |     |
| 10       | 111 8654  | 1          | DICHTRING         | WASHER          | BAGUE D ETANCHEITE | ANILLO DE JUNTA    | A 8 X 14 DIN 7603-CU  |     |
| 11       | 232 1971  | 1          | HEBEL             | LEVER/ARM       | LEVIER             | PALANCA            |                       |     |
| 12       | 110 8132  | 1          | SECHSKANTSCHRAUBE | HEX-BOLT        | VIS 6 PANS         | TORNILLO HEXAGONAL | M 8X 15 DIN 561- 5-8  |     |
| 17       | 110 7549  | 1          | SCHEIBE           | DISC/PANE/PLATE | RONDELLE/DISQUE    | DISCO              | 10-5DIN 433-ST        |     |



VORDERRADANTRIEB  
FRONT WHEEL DRIVE  
COMMANDE DES ROUES AV  
PROPULSION DELANTERA

1446-26 500 4203

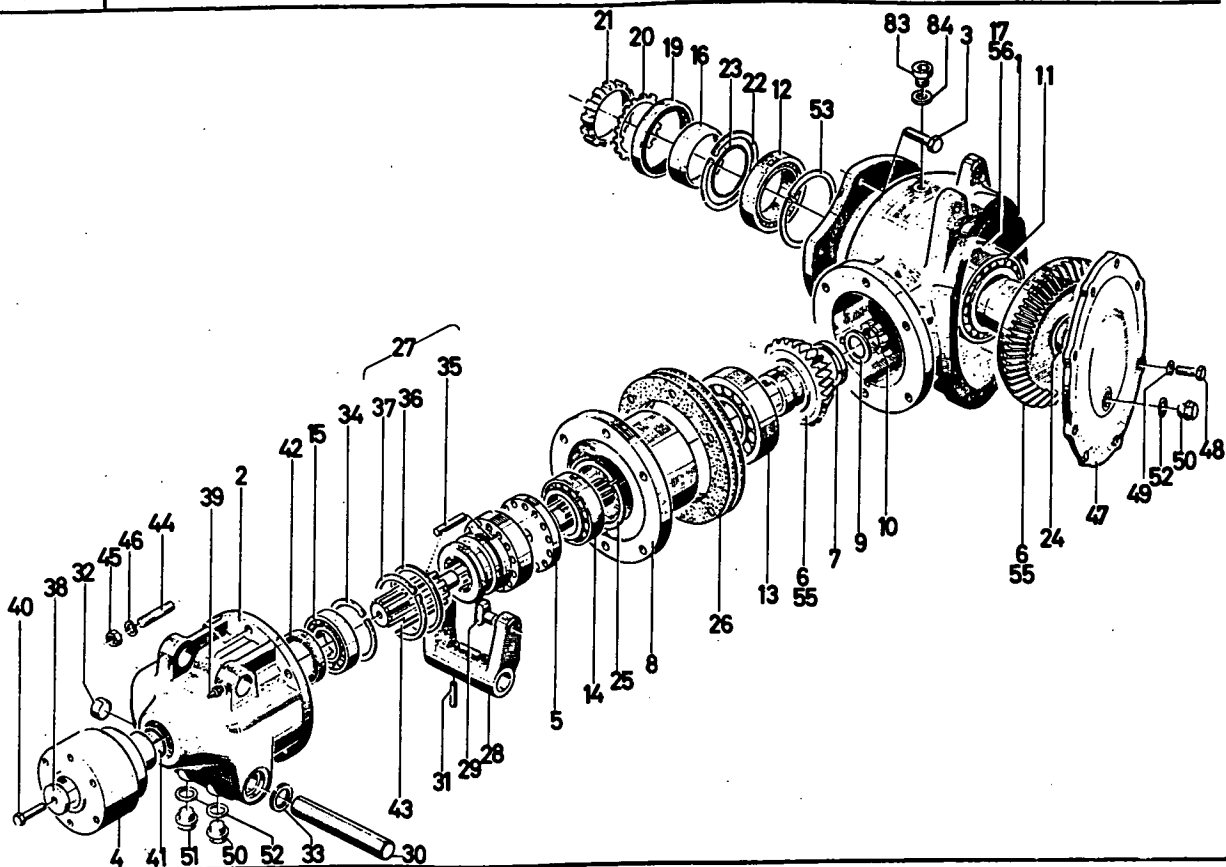

1446-26 500 4203

| Bild Nr. | Teil-Nr. | Stück-Zahl | Deutsch           | English            | Français           | Español            | Nummer/Bemerkung   | ETK |
|----------|----------|------------|-------------------|--------------------|--------------------|--------------------|--|-----|
| 1        | 231 6231 | 1          | GEMÄUSE           | HOUSING/CASE       | CARTER/BOITIER     | CAJA/BLOQUE/CUERPO |  |     |
| 2        | 232 5661 | 1          | SCHALTGEMÄUSE     | HOUSING            | CARTER COMMANDE    | CAJA CAMBIO/MANDO  |  |     |
| 3        | 110 8785 | 5          | SECHSKANTSCHRAUBE | HEX-BOLT           | VIS 6 PANS         | TORNILLO HEXAGONAL | M12 X 45 DIN 609-M 8-8   |     |
| 4        | 231 5409 | TM         | KUPPLUNG          | CLUTCH/COUPLING    | ACCOUPL/EMBRAYAGE  | EMBRAGUE/ACOPLE    | 8313-TEILENUMMER-LISTENBLATT<br>1446-26 500 3076                                       |     |
| 5        | 231 5980 | 1          | FLANSCHWELLE      | FLANGED SHAFT      | ARBRE A BRIDE      | EJE BRIDA          |  |     |
| 6        | 231 9524 | 1          | KEGELTRIEB        | BEVEL DRIVE        | COUPLE CONIQUE     | GRUPO CONICO       | 18/29 TM 50-TM 50-1 N+S<br>894-FUER BEREIFUNG<br>11-32/13-28                           |     |
| 7        | 231 5981 | 1          | SCHEIBE           | DISC/PANE/PLATE    | RONDELLE/DISQUE    | DISCO              |  |     |
| 8        | 230 6225 | 1          | FLANSCHBUCHSE     | FLANGED BUSH       | DOUILLE A BRIDE    | CASQUILLO ERIDA    |  |     |
| 9        | 121 1692 | 1          | SICHERUNGSBLECH   | LOCKING PLATE      | TOLE DE SECURITE   | CHAPA SEGURIDAD    | 2 250 A 9 IN KLAMMER   |     |
| 10       | 121 1693 | 1          | NUTMUTTER         | GROOVED NUT        | ECROU RAINURE      | TUERCA PANURADA    | 2 174 B 30 IN KLAMMER  |     |
| 11       | 110 9965 | 1          | KEGELROLLENLAGER  | TAP-ROLLER BEARING | ROULEM A ROUL CON  | COJ-RODIL-CONICOS  | 30214J20IN 720   | 01  |
| 12       | 111 1596 | 1          | KEGELROLLENLAGER  | TAP-ROLLER BEARING | ROULEM A ROUL CON  | COJ-RODIL-CONICOS  | M12X 170 DIN 921-PIE-9-A4C   | 01  |
| 13       | 112 5780 | 1          | KEGELROLLENLAGER  | TAP-ROLLER BEARING | ROULEM A ROUL CON  | COJ-RODIL-CONICOS  | 30311J20IN 720   | 01  |
| 14       | 110 1597 | 1          | KEGELROLLENLAGER  | TAP-ROLLER BEARING | ROULEM A ROUL CON  | COJ-RODIL-CONICOS  | 32011X DIN 720   | 01  |
| 15       | 110 9062 | 1          | RILLENKUGELLAGER  | BALL BEARING       | ROUL RAINURE BILLE | COJ-BOLAS FIJO     | 6208 DIN 625   | 01  |
| 16       | 230 6297 | 1          | ABSTÄNDRING       | SPACER RING        | BAGUE ECAFTEMENT   | ARO DISTANCIARIO   |  |     |
| 17       | 230 6739 | MB         | BEILAGE           | SHIM               | CALE               | SUPLEMENTO         | A 3-0 MM--8285-S-POS-950-966<br>TM 50-TM 50-3 N+S<br>894-FUER BEREIFUNG<br>11-32/13-28 |     |
| 19       | 116 0701 | 1          | WELLENDICHTRING   | SHAFT SEAL         | JOINT D ARBRE      | ANILLO PERMET-EJE  | A 80X100 X10 H 2940-NI   | 01  |
| 20       | 230 6235 | 1          | SICHERUNGSBLECH   | LOCKING PLATE      | TOLE DE SECURITE   | CHAPA SEGURIDAD    |  | 01  |
| 21       | 112 0618 | 1          | NUTMUTTER         | GROOVED NUT        | ECROU RAINURE      | TUERCA PANURADA    | M 65X1,5 DIN70252  |     |
| 22       | 110 7862 | 1          | SICHERUNGSRING    | CIRCLIP            | CIRCLIP            | CIRCLIP            | 100X3 DIN 472  |     |

| Bld Nr. | Teil-Nr. | Stück-Zahl | Deutsch            | English           | Français           | Español            | Nummer/Bemerkung  | ETX |
|---------|----------|------------|--------------------|-------------------|--------------------|--------------------|---|-----|
| 23      | 116 9588 | 1          | RUNDGUMRING        | O-SEAL            | ANNEAU TORIQUE     | ANILLO GOMA REDOND | 65 X 2 H 721  | 01  |
| 24      | 238 4210 | 1          | ENTLUEFTUNGSROHR   | BREATHER PIPE     | TUBE DE DESAERAGE  | TUBO PRE-AIRE      |   |     |
| 25      | 110 7859 | 1          | SICHERUNGSRING     | CIRCLIP           | CIRCLIP            | CIRCLIP            | 90X4 DIN 472  |     |
| 26      | 230 6294 | SZ         | BEILAGE            | SHIM              | CALE               | SUPLEMENTO         | 8076-FINZELTEILE SIEHE POS.<br>984-989.   |     |
| 27      | 230 6238 | 1          | BOLZENTRAEGER      | PIN CARRIER       | PORTE-DOIGTS       | PORTABULONES       |   |     |
| 28      | 230 6227 | 1          | SCHALTEABEL        | SHIFT FORK        | FOURCHETTE CDE     | HORQUILLA CAMBIO   |   |     |
| 29      | 230 6242 | 2          | GLEITSTEIN         | SLIDER            | GRAIN COULISSANT   | DADO DESLIZANTE.   |   |     |
| 30      | 230 6244 | 1          | SCHALTWELLE        | SHIFTING SHAFT    | ARBRE COMMANDE     | EJE MANEJO/CAMBIO  |   |     |
| 31      | 111 5458 | 2          | SPANNHLEISE        | DOWN SLEEVE       | DOUILLE SERRAGE    | CASQUILLO FIADOR   | 6 X 40DIN 1481  |     |
| 32      | 116 5830 | 1          | KERNLOCHVERSCHLUSS | CORE HOLE PLUG    | BOUCHON TROU DESS  | CIERRE PACHO       | 925 H 711   |     |
| 33      | 111 7617 | 1          | WELLENDICHTRING    | SHAFT SEAL        | JOINT D APBRE      | ANILLO HERMET-EJE  | A 25X 35DIN 6503  | 01  |
| 34      | 110 7855 | 1          | SICHERUNGSRING     | CIRCLIP           | CIRCLIP            | CIRCLIP            | 80X2,5 DIN 472  |     |
| 35      | 230 6240 | 16         | SCHALTEOLZEN       | SHIFT PIN         | AXE COMMANDE       | BULON CAMBIO       |   | 01  |
| 36      | 230 6241 | 1          | RING               | RING              | BAGUE/ANNEAU       | ANILLO             |   |     |
| 37      | 110 7782 | 1          | SICHERUNGSRING     | CIRCLIP           | CIRCLIP            | CIRCLIP            | 75X2,5 DIN 471  | 01  |
| 38      | 231 0951 | 1          | SCHEIBE            | DISC/PANE/PLATE   | RONDELLE/DISQUE    | DISCO              |   |     |
| 39      | 116 8225 | 2          | SCHNIEFNIPPEL      | LUBE FITTING      | RACCORD GRAISSEUR  | NIPLE LUBRICACION  | SA 8H 3360  | 01  |
| 40      | 116 6836 | 1          | SKY-DEFNSCHRAUBE   | WAISTED BOLT      | VIS EXTENS 6 PANS  | TORN-HEY-EXPANSION | M10X1 X 40 H 803-10-9   | 01  |
| 41      | 116 1561 | 1          | O-RING             | O-SEAL            | BAGUE TORIQUE      | ANILLO O           | 38 X2 H 2927  | 01  |
| 42      | 116 1562 | 1          | WELLENDICHTRING    | SHAFT SEAL        | JOINT D ARBRE      | ANILLO HERMET-EJE  | B 50X 70 X10 H 2940-NI  | 01  |
| 43      | 230 7445 | 1          | ABTRIEESWELLE      | OUTPUT SHAFT      | ARBRE SECONDAIRE   | EJE SECUNDARIO     |   |     |
| 44      | 111 3479 | 6          | STIFTSCHRAUBE      | STUD              | GOUJON             | ESPARRAGO          | AM10X 40 DIN 929- 6.4   |     |
| 45      | 110 2659 | 6          | SECHSKANTMUTTER    | HEX-NUT           | ECROU 6 PANS       | TUERCA HEXAGONAL   | M10 DIN 934-M 2 A4C   |     |
| 46      | 110 2800 | 6          | FEDERRING          | SPRING LOCKWASHER | RONDELLE GROWER    | ARANDELA ELASTICA  | A 10 DIN 128 A4C  |     |
| 47      | 230 6223 | 1          | BECKEL             | COVER             | COUVERCLE          | TAPA               |   |     |
| 48      | 111 2322 | 8          | SECHSKANTSCHRAUBE  | HEX-BOLT          | VIS 6 PANS         | TORNILLO HEXAGONAL | M 8X 20 DIN 933- 6.8-A4C  |     |
| 49      | 110 2799 | 8          | FEDERRING          | SPRING LOCKWASHER | RONDELLE GROWER    | ARANDELA ELASTICA  | A 8 DIN 128 A4C   |     |
| 50      | 111 8980 | 2          | VERSCHLUSSSCHRAUBE | SCREW PLUG        | BOUCHON FILETE     | TAPON ROSCADO      | AM22X1,5 DIN 7604 VZKC  |     |
| 51      | 121 8437 | 1          | VERSCHLUSSSCHRAUBE | SCREW PLUG        | BOUCHON FILETE     | TAPON ROSCADO      | 2 814 M 2   | 01  |
| 52      | 111 8737 | 3          | DICHTRING          | WASHER            | BAGUE D ETANCHEITE | ANILLO DE JUNTA    | A 22 X 27 DIN 7602-CU   |     |
| 53      | 110 1512 | 1          | SICHERUNGSRING     | CIRCLIP           | CIRCLIP            | CIRCLIP            | 100X4 DIN 472   |     |
| 55      | 231 9525 | 1          | KEGELTRIEB         | BEVEL DRIVE       | COUPLE CONIQUE     | GRUPO CONICO       | 16/29 TH 35.3 A.78 35.3 +<br>8094-FUER BEREIFUNG<br>11-32/9-3E  |     |
| 56      | 230 6938 | NB         | BEILAGE            | SHIM              | CALE               | SUPLEMENTO         | A-7.0 00-S-POS-967-9A3<br>TH 35.3 N. TH 35.3 N+S<br>8094-FUER BEREIFUNG<br>11-32/9-3E                 |     |
| 83      | 111 8998 | 1          | VERSCHLUSSSCHRAUBE | SCREW PLUG        | BOUCHON FILETE     | TAPON ROSCADO      | M10X1 DIN 7604 VZKC<br>8042-BEI ERSTMALIGEM ERSATZ<br>BIS FAHRGESTELL-NO<br>POS. 24, 84 MITLIEFERN    |     |
| 84      | 111 8659 | 1          | DICHTRING          | WASHER            | BAGUE D ETANCHEITE | ANILLO DE JUNTA    | A 10 X 13.5DIN 7602-CU<br>8042-BEI ERSTMALIGEM ERSATZ<br>BIS FAHRGESTELL-NO<br>POS. 24, 83 MITLIEFERN |     |
| 950     | 230 6739 | NB         | BEILAGE            | SHIM              | CALE               | SUPLEMENTO         | A 3.1   |     |
| 951     | 230 6740 | NB         | BEILAGE            | SHIM              | CALE               | SUPLEMENTO         | A 3.2   |     |
| 952     | 230 6741 | NB         | BEILAGE            | SHIM              | CALE               | SUPLEMENTO         | A 3.3   |     |
| 953     | 230 6742 | NB         | BEILAGE            | SHIM              | CALE               | SUPLEMENTO         | A 3.4   |     |
| 954     | 230 6743 | NB         | BEILAGE            | SHIM              | CALE               | SUPLEMENTO         | A 3.5   |     |
| 955     | 230 6745 | NB         | BEILAGE            | SHIM              | CALE               | SUPLEMENTO         | A-3.6   |     |

| Bld<br>Nr. | Teil-Nr. | Stück-<br>Zahl | Deutsch | English | Français | Español    | Nummer/Bemerkung | ETK |
|------------|----------|----------------|---------|---------|----------|------------|------------------|-----|
| 156        | 230 6746 | NB             | BEILAGE | SHIM    | CALE     | SUPLEMENTO | A-3.7            |     |
| 157        | 230 6747 | NB             | BEILAGE | SHIM    | CALE     | SUPLEMENTO | A 3.8            |     |
| 158        | 230 6748 | NB             | BEILAGE | SHIM    | CALE     | SUPLEMENTO | A 3.9            |     |
| 159        | 230 6749 | NE             | BEILAGE | SHIM    | CALE     | SUPLEMENTO | A 4.0            |     |
| 160        | 230 6750 | NB             | BEILAGE | SHIM    | CALE     | SUPLEMENTO | A 4.1            |     |
| 161        | 230 6751 | NB             | BEILAGE | SHIM    | CALE     | SUPLEMENTO | A 4.2            |     |
| 162        | 230 6752 | NB             | BEILAGE | SHIM    | CALE     | SUPLEMENTO | A 4.3            |     |
| 163        | 230 6753 | NB             | BEILAGE | SHIM    | CALE     | SUPLEMENTO | A 4.4            |     |
| 164        | 230 6754 | NE             | BEILAGE | SHIM    | CALE     | SUPLEMENTO | A 4.5            |     |
| 165        | 230 6755 | NB             | BEILAGE | SHIM    | CALE     | SUPLEMENTO | A 4.6            |     |
| 166        | 230 6756 | NB             | BEILAGE | SHIM    | CALE     | SUPLEMENTO | A 4.7            |     |
| 167        | 230 6759 | NB             | BEILAGE | SHIM    | CALE     | SUPLEMENTO | A 7.1            |     |
| 168        | 230 6760 | NB             | BEILAGE | SHIM    | CALE     | SUPLEMENTO | A 7.2            |     |
| 169        | 230 6761 | NB             | BEILAGE | SHIM    | CALE     | SUPLEMENTO | A 7.3            |     |
| 170        | 230 6762 | NB             | BEILAGE | SHIM    | CALE     | SUPLEMENTO | A 7.4            |     |
| 171        | 230 6763 | NB             | BEILAGE | SHIM    | CALE     | SUPLEMENTO | A 7.5            |     |
| 172        | 230 6764 | NB             | BEILAGE | SHIM    | CALE     | SUPLEMENTO | A 7.6            |     |
| 173        | 230 6765 | NB             | BEILAGE | SHIM    | CALE     | SUPLEMENTO | A 7.7            |     |
| 174        | 230 6766 | NB             | BEILAGE | SHIM    | CALE     | SUPLEMENTO | A 7.8            |     |
| 175        | 230 6767 | NB             | BEILAGE | SHIM    | CALE     | SUPLEMENTO | A 7.9            |     |
| 176        | 230 6768 | NB             | BEILAGE | SHIM    | CALE     | SUPLEMENTO | A 8.0            |     |
| 177        | 230 6769 | NB             | BEILAGE | SHIM    | CALE     | SUPLEMENTO | A 8.1            |     |
| 178        | 230 6770 | NB             | BEILAGE | SHIM    | CALE     | SUPLEMENTO | A 8.2            |     |
| 179        | 230 6771 | NB             | BEILAGE | SHIM    | CALE     | SUPLEMENTO | A 8.3            |     |
| 180        | 230 6772 | NB             | BEILAGE | SHIM    | CALE     | SUPLEMENTO | A 8.4            |     |
| 181        | 230 6773 | NB             | BEILAGE | SHIM    | CALE     | SUPLEMENTO | A 8.5            |     |
| 182        | 230 6774 | NB             | BEILAGE | SHIM    | CALE     | SUPLEMENTO | A 8.6            |     |
| 183        | 230 6775 | NB             | BEILAGE | SHIM    | CALE     | SUPLEMENTO | A 8.7            |     |
| 184        | 230 6776 | NB             | BEILAGE | SHIM    | CALE     | SUPLEMENTO | A 0.6            |     |
| 185        | 230 6732 | NB             | BEILAGE | SHIM    | CALE     | SUPLEMENTO | A 0.7            |     |
| 186        | 230 6733 | NE             | BEILAGE | SHIM    | CALE     | SUPLEMENTO | A 0.8            |     |
| 187        | 230 6734 | NB             | BEILAGE | SHIM    | CALE     | SUPLEMENTO | A 0.9            |     |
| 188        | 230 6735 | NB             | BEILAGE | SHIM    | CALE     | SUPLEMENTO | A 1.0            |     |
| 189        | 230 6730 | NB             | BEILAGE | SHIM    | CALE     | SUPLEMENTO | A 0.5 MM         |     |

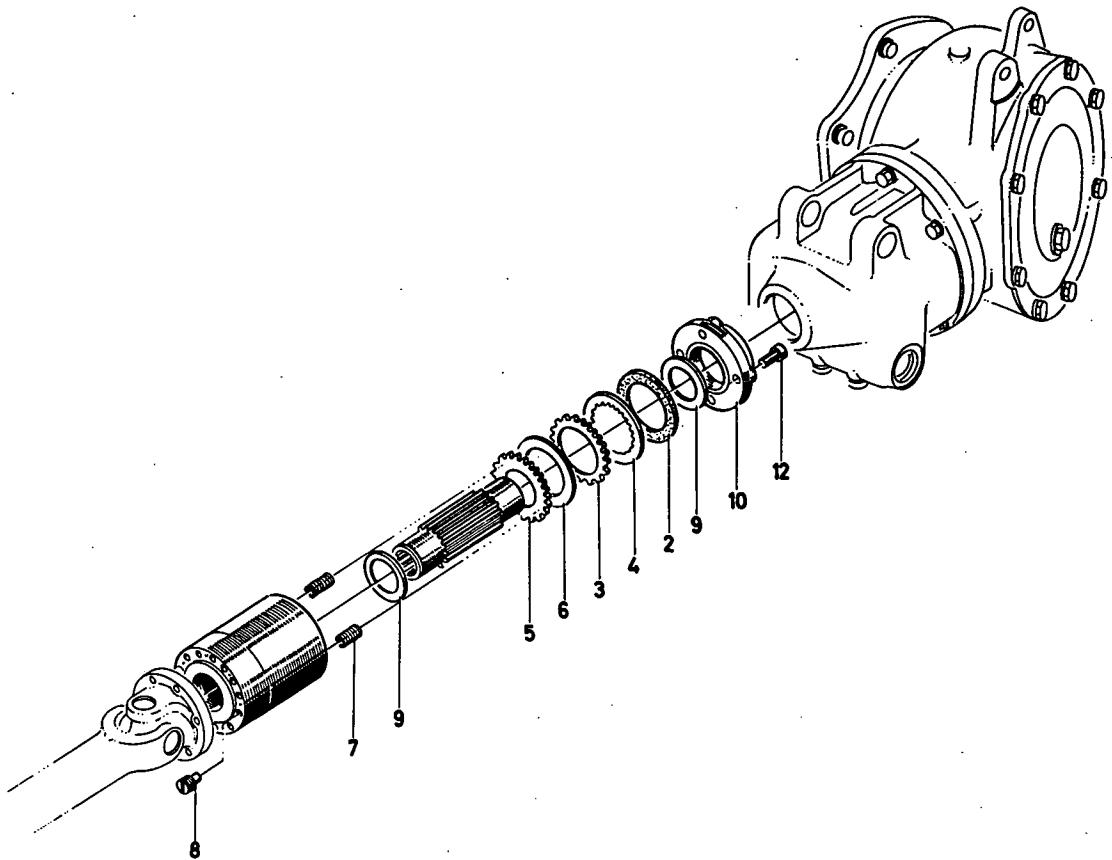

1446-26 500 3076

| Bild Nr. | Teil-Nr. | Stück-Zahl | Deutsch       | English            | Français           | Español            | Nummer/Bemerkung | ETK |
|----------|----------|------------|---------------|--------------------|--------------------|--------------------|------------------|-----|
| 2        | 231 5416 | 1          | DRUCKSCHEIBE  | THRUST PLATE       | RONDELLE DE BUTEE  | ARANDELA PRESION   |                  |     |
| 3        | 231 5417 | 19         | AUSSENLAMELLE | EXT-TOOTHED DISC   | LAMELLE DENT EXT   | LAM-DENT EXTER.    |                  |     |
| 4        | 231 0575 | 18         | INNENLAMELLE  | INT-TOOTHED DISC   | LAMELLE INTERIEURE | LAMINA DENT-INTER. |                  |     |
| 5        | 231 5418 | 1          | AUSSENLAMELLE | EXT-TOOTHED DISC   | LAMELLE DENT EXT   | LAM-DENT EXTER.    |                  |     |
| 6        | 231 5419 | 1          | LAMELLE       | DISC               | LAMELLE            | LAMINA             |                  |     |
| 7        | 231 5420 | 12         | DRUCKFEDER    | COMPRESSION SPRING | RESSORT DE COMPR   | RESORTE PRESION    |                  |     |
| 8        | 231 0578 | 12         | GEWINDESTIFT  | GRUB SCREW         | GOUPILLE FILETEE   | PERNO ROSCADO      |                  |     |
| 9        | 231 0579 | 2          | ZWISCHENRING  | INTERMEDATE RING   | BAGUE INTERMED.    | ANILLO INTERMEDIO  |                  |     |
| 10       | 231 0576 | 1          | FLANSCHNABE   | FLANGED HUB        | MOYEU A BRIDE      | CUBO BRIDA         |                  |     |
| 12       | 231 0582 | 4          | SCHRAUBE      | SCREW/BOLT         | VIS/BOULON         | TORNILLO           |                  |     |

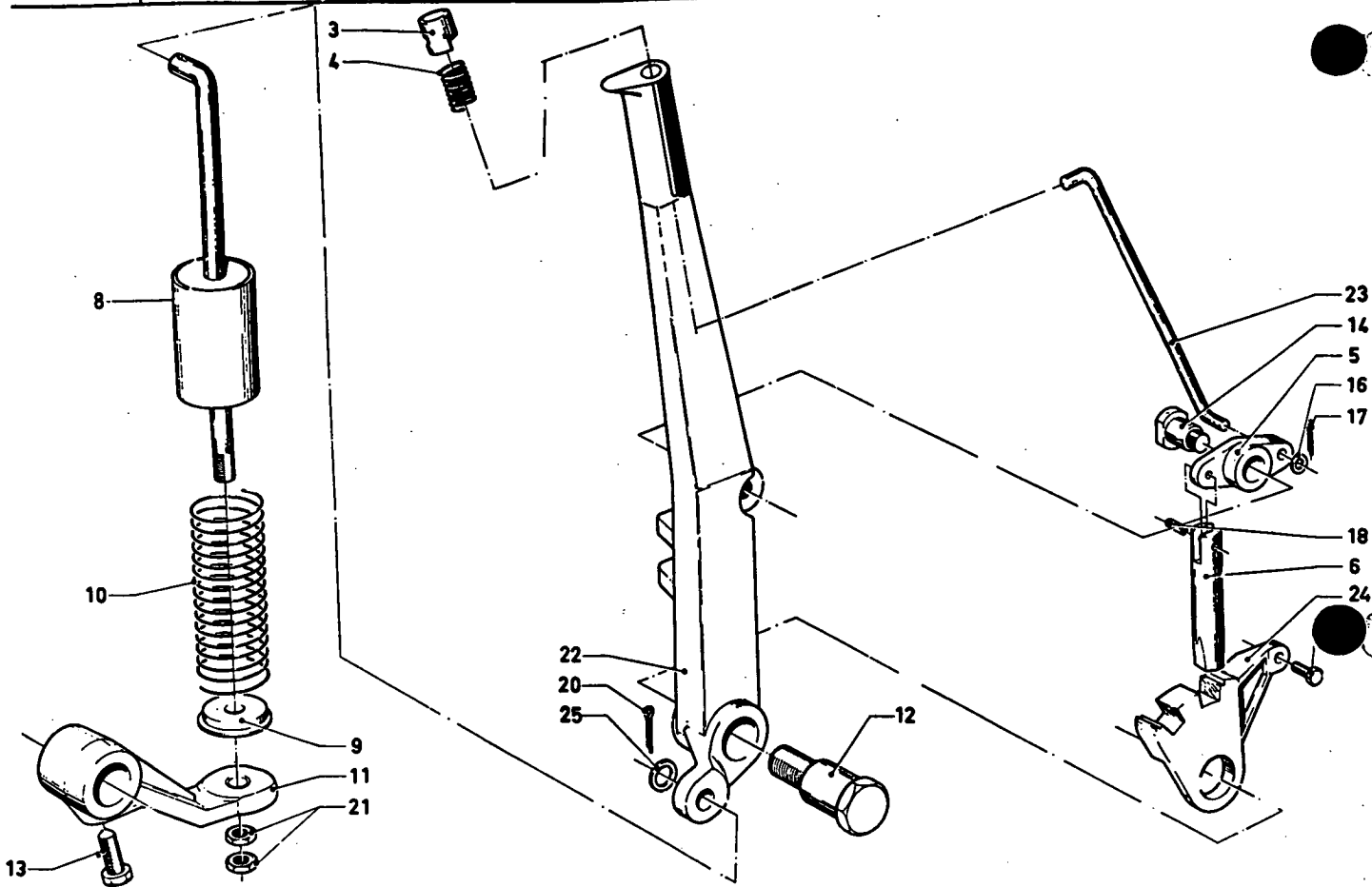

| Bild Nr. | Teil-Nr. | Stück-Zahl | Deutsch           | English            | Français           | Español            | Nummer / Bemerkung       | ETK |
|----------|----------|------------|-------------------|--------------------|--------------------|--------------------|--------------------------|-----|
| 3        | 338 8929 | 1          | DRUCKKNÖPF        | PUSHBUTTON         | BOUTON-POUSSOIR    | PULSADOR           | 1136-29-03-07            |     |
| 4        | 338 8928 | 1          | SCHRAUBENFEDER    | HELICAL SPRING     | RESSORT A BOUDIN   | RESORTE HELICOIDAL | 1136-29-03-06            | 03  |
| 5        | 230 6258 | 1          | UMLENKHEBEL       | REVERSING LEVER    | LEVIER DE RENVOI   | PALANCA INVERSION  |                          |     |
| 6        | 230 6257 | 1          | STIFT             | PIN                | CHEVILLE/GOUPILLE  | PERNO/PASADOR      |                          |     |
| 8        | 230 6251 | 1          | SCHALTSTANGE      | SHIFT ROD          | BARRE ENBRAYAGE    | BARRA CAMBIO       |                          |     |
| 9        | 230 6246 | 1          | FEDERTELLER       | SPRING CAP         | CUVETTE DE RESSORT | PLATO RESORTE      |                          |     |
| 10       | 230 6247 | 1          | DRUCKFEDER        | COMPRESSION SPRING | RESSORT DE COMPR   | RESORTE PRESION    |                          |     |
| 11       | 230 6245 | 1          | SCHALTHEBEL       | SHIFT LEVER        | LEVIER COMMANDE    | PALANCA CAMBIO     |                          |     |
| 12       | 230 6256 | 1          | BOLZEN            | PIN/BOLT/STUD      | BOULON/AXE         | BULON              |                          |     |
| 13       | 230 1561 | 1          | STELLSCHRAUBE     | SET SCREW          | VIS DE REGLAGE     | TORNILLO GRADUAC-  |                          |     |
| 14       | 111 5001 | 1          | BOLZEN            | PIN/BOLT/STUD      | BOULON/AXE         | BULON              | 12H11M10X 13 X 28DIN     |     |
| 15       | 111 2918 | 1          | SECHSKANTSCHRAUBE | HEX-BOLT           | VIS 6 PANS         | TORNILLO HEXAGONAL | M10X 25 DIN 933- 8-8-A4C |     |
| 16       | 110 7095 | 1          | SCHWEIBE          | DISC/PANE/PLATE    | RONDELLE/DISQUE    | DISCO              | A 6-40DIN 125-ST-A4C     |     |
| 17       | 110 6404 | 1          | SPLINT            | SPLIT PIN          | GOUPILLE FENDUE    | PASADOR ALETAS     | 2 X 12DIN 94-A4C         |     |
| 18       | 111 5407 | 1          | SPANNHUELSE       | DOWEL SLEEVE       | DOUILLE SERRAGE    | CASQUILLO FIADOR   | 3 X 16DIN 1481           |     |
| 20       | 110 6447 | 1          | SPLINT            | SPLIT PIN          | GOUPILLE FENDUE    | PASADOR ALETAS     | 4 X 20DIN 94-A4C         |     |
| 21       | 111 3153 | 2          | SECHSKANTMUTTER   | HEX-NUT            | ECROU 6 PANS       | TUERCA HEXAGONAL   | M12 DIN 936-M6S-A4C      |     |
| 22       | 231 5423 | 1          | HANDHEBEL         | HAND LEVER         | LEVIER A MAIN      | PALANCA MANUAL     |                          |     |
| 23       | 231 5424 | 1          | DRUCKSTANGE       | THRUST ROD         | BRAS DE LEVIER     | VARRILLA PRESION   |                          |     |
| 24       | 231 5425 | 1          | SEGMENT           | QUADRANT/SEGMENT   | SEGMENT/SECTEUR    | SEGMENTO           |                          |     |
| 25       | 110 7554 | 1          | SCHWEIBE          | DISC/PANE/PLATE    | RONDELLE/DISQUE    | DISCO              | 13-50DIN 933-ST-A4C      |     |



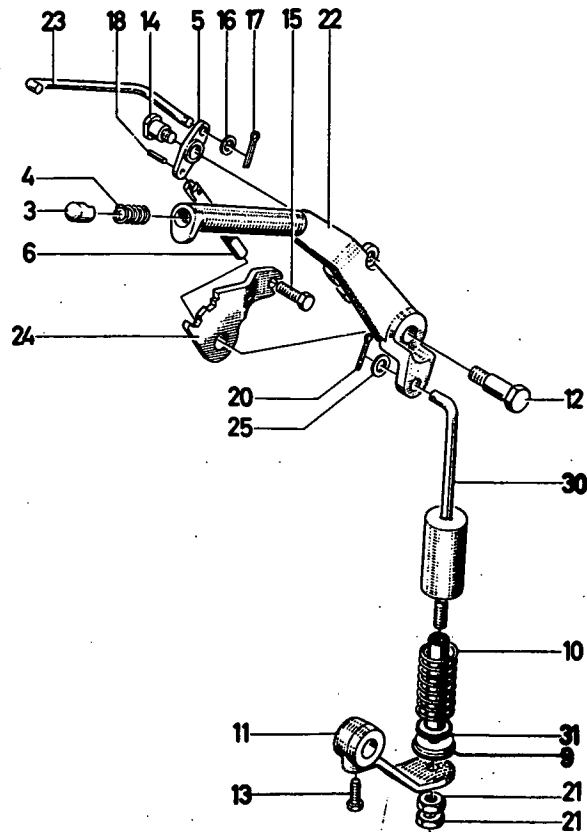

1446-26 500 5346

| Bild Nr. | Teile-Nr. | Stück-Zahl | Deutsch           | English            | Français           | Español            | Nummer/Bemerkung        | ETK |
|----------|-----------|------------|-------------------|--------------------|--------------------|--------------------|-------------------------|-----|
| 3        | 338 8727  | 1          | DRUCKKNOPF        | PUSHBUTTON         | BOUTON-POUSSOIR    | PULSADOR           | 1136-27-03-07           |     |
| 4        | 338 8728  | 1          | SCHRAUBENFEDER    | HELICAL SPRING     | RESSORT A BOUDIN   | RESORTE HELICOIDAL | 1136-27-03-06           | 01  |
| 5        | 230 6258  | 1          | LENKENHEBEL       | REVERSING LEVER    | LEVIER DE RENVOI   | PALANCA INVERSION  |                         |     |
| 6        | 230 6257  | 1          | STIFT             | PIN                | CHEVILLE/GOUPILLE  | PERNO/PASADOR      |                         |     |
| 7        | 230 6246  | 1          | FEDERTELLER       | SPRING CAP         | CUVETTE DE RESSORT | PLATO RESORTE      |                         |     |
| 10       | 230 6247  | 1          | DRUCKFEDER        | COMPRESSION SPRING | RESSORT DE COMPR   | RESORTE PRESION    |                         |     |
| 11       | 230 6245  | 1          | SCHALTHEBEL       | SHIFT LEVER        | LEVIER COMMANDE    | PALANCA CAMBIO     |                         |     |
| 12       | 230 6256  | 1          | BOLZEN            | PIN/BOLT/STUD      | BOULON/AXE         | BULON              |                         |     |
| 13       | 230 1561  | 1          | STELLSCHRAUBE     | SET SCREW          | VIS DE REGLAGE     | TORNILLO GRADUAC-  |                         |     |
| 14       | 111 5001  | 1          | BOLZEN            | PIN/BOLT/STUD      | BOULON/AXE         | BULON              | 12H11M10X 13 X 28DIN    |     |
| 15       | 111 2418  | 1          | SECHSKANTSCHRAUBE | HEX-BOLT           | VIS 6 PANS         | TORNILLO HEXAGONAL | M10X 25 DIN 933-8.8-A4C |     |
| 16       | 110 7095  | 1          | SCHEIBE           | DISC/PANE/PLATE    | RONDELLE/DISQUE    | DISCO              | A 6.4DIN 125-ST-A4C     |     |
| 17       | 110 6404  | 1          | SPLINT            | SPLIT PIN          | GOUPILLE FENDUE    | PASADOR ALETAS     | 2 X 12DIN 94-A4C        |     |
| 18       | 111 5407  | 1          | SPANNHUELSE       | BOWEL SLEEVE       | DOUILLE SERRAGE    | CASQUILLO FIADOR   | 3 X 16DIN 1443          |     |
| 20       | 110 6447  | 1          | SPLINT            | SPLIT PIN          | GOUPILLE FENDUE    | PASADOR ALETAS     | 4 X 20DIN 94-A4C        |     |
| 21       | 111 3153  | 2          | SECHSKANTMUTTER   | HEX-NUT            | ECROU 6 PANS       | TUERCA HEXAGONAL   | M12 DIN 936-M6.8-A4C    |     |
| 22       | 231 5423  | 1          | HANDHEBEL         | HAND LEVER         | LEVIER A MAIN      | PALANCA MANUAL     |                         |     |
| 23       | 231 5424  | 1          | DRUCKSTANGE       | THRUST ROD         | BRAS DE LEVIER     | VARILLA PRESION    |                         |     |
| 24       | 231 5425  | 1          | SEGMENT           | QUADRANT/SEGMENT   | SEGMENT/SECTEUR    | SEGMENTO           |                         |     |
| 25       | 110 7554  | 1          | SCHEIBE           | DISC/PANE/PLATE    | RONDELLE/DISQUE    | DISCO              | 13.5DIN 933-ST-A4C      |     |
| 30       | 237 1399  | 1          | SCHALTSTANGE      | SHIFT ROD          | BARRE EMBRAYAGE    | BARRA CAMBIO       |                         |     |
| 31       | 237 1395  | 1          | ABSTANDROHR       | SPACER TUBE        | TUBE ECARTEMENT    | TUBO DISTANCIARIO  |                         |     |

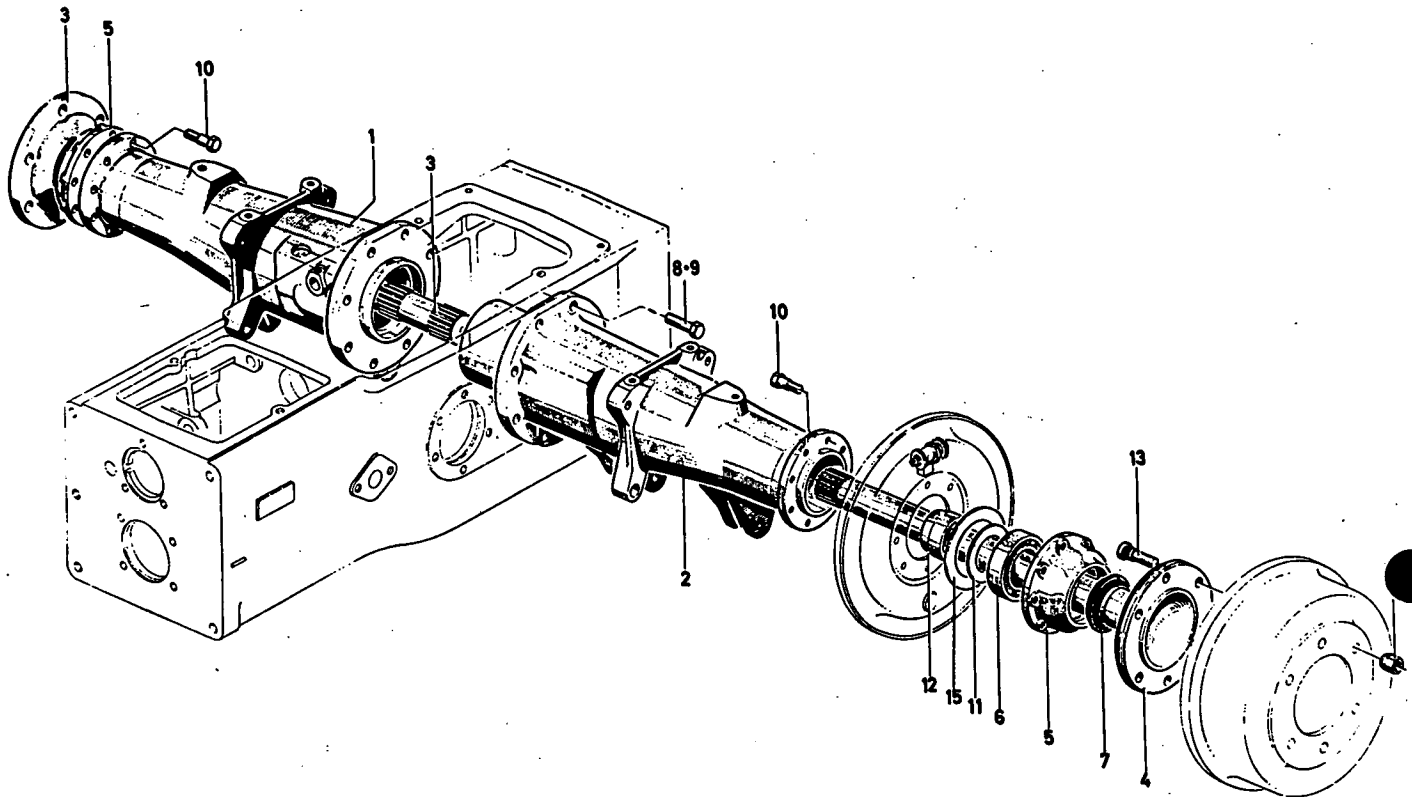

1434-27 500 4205

| Bild Nr. | Teile-Nr. | Stück-Zahl | Deutsch           | English         | Français           | Español            | Nummer/Bemerkung             | ETK |
|----------|-----------|------------|-------------------|-----------------|--------------------|--------------------|------------------------------|-----|
| 1        | 233 2895  | 1          | TRAGROHR          | SUPPORT TUBE    | TROMPETTE          | TROMPETA EJE       | 8267-RECHT                   |     |
| 2        | 233 2893  | 1          | TRAGROHR          | SUPPORT TUBE    | TROMPETTE          | TROMPETA EJE       | 8195-LINKS                   |     |
| 3        | 339 2347  | 1          | HINTERACHSHAELFTE | SIDE SHAFT      | DEMI-ESSIEU ARRIER | SEMIEJE TRASERO    | 1434-27-01-02<br>8267-RECHTS |     |
| 4        | 339 2346  | 1          | HINTERACHSHAELFTE | SIDE SHAFT      | DEMI-ESSIEU ARRIER | SEMIEJE TRASERO    | 1434-27-01-01<br>8195-LINKS  |     |
| 5        | 339 2375  | 2          | LAGERGEHAUSE      | BEARING HOUSING | BOITIER DE PALIER  | CAJA SOPORTE       | 1435-27-01-05                |     |
| 6        | 110 9074  | 2          | RILLENKUGELLAGER  | BALL BEARING    | ROUL RAINURE BILLE | COJ.BOLAS FIJO     | 6211 DIN 625                 | 01  |
| 7        | 116 0854  | 2          | WELLENDICHTRING   | SHAFT SEAL      | JOINT D ARBRE      | ANILLO HERMET-EJE  | 5 65X 85 X13 H 2940-NI       | 01  |
| 8        | 111 2624  | 12         | SECHSKANTSCHRAUBE | HEX-BOLT        | VIS 6 PANS         | TORNILLO HEXAGONAL | M14X 40 DIN 933-M 8.8 ANC    |     |
| 9        | 111 2631  | 4          | SECHSKANTSCHRAUBE | HEX-BOLT        | VIS 6 PANS         | TORNILLO HEXAGONAL | M14X 45 DIN 933-M 8.8 ANC    |     |
| 10       | 339 2087  | 16         | SKT-PASSSCHRAUBE  | FITTED BOLT     | VIS AJUST 6 PANS   | TORN-HEX-CALIBR-   | 1424-27-01-13                |     |
| 11       | 339 2378  | 2          | ABDECKBLECH       | COVER PLATE     | TOLE RECOUVREMENT  | CHAPA RECUBRINIEN- | 1435-27-01-24                |     |
| 12       | 338 7606  | 2          | RING              | RING            | BAGUE/ANNEAU       | ANILLO             | 1124-27-01-09                |     |
| 13       | 332 7796  | 12         | SCHRAUBE          | SCREW/BOLT      | VIS/BOULON         | TORNILLO           | 524 697 H                    |     |
| 14       | 112 3546  | 12         | KUGELBUNDMUTTER   | SHOULDER NUT    | ECROU COLLET SPHER | TUERC-COLLAR-ESFER | A18 DIN74361-6S VZKC         |     |
| 15       | 339 2377  | 2          | BEILAGE           | SHIM            | CALE               | SUPLEMENTO         | 1435-27-01-23                |     |

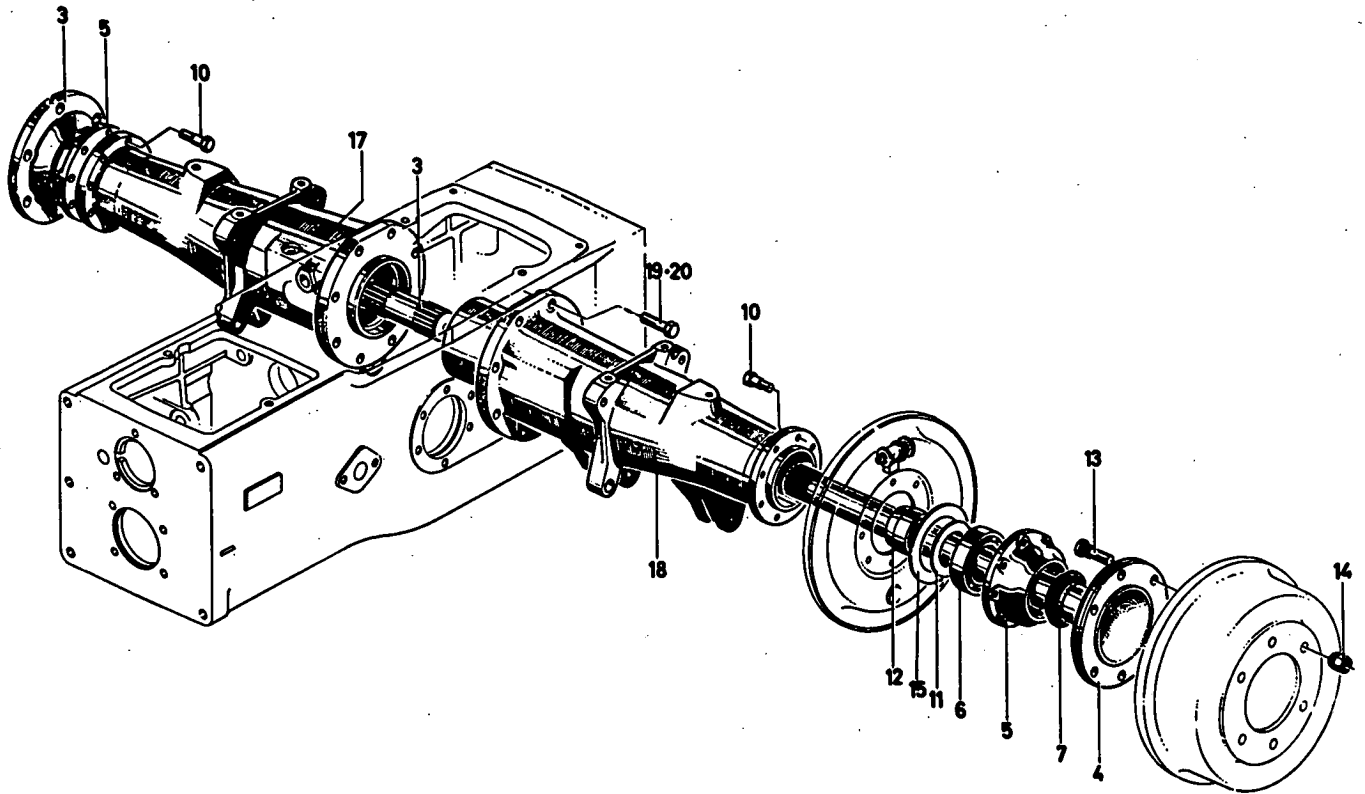

1435-27 502 0207

| Bld. Nr. | Teil-Nr. | Stück-Zahl | Deutsch           | English         | Français           | Español            | Nummer/Bemerkung             | ETK |
|----------|----------|------------|-------------------|-----------------|--------------------|--------------------|------------------------------|-----|
| 3        | 339 2347 | 1          | HINTERACHSHAELFTE | SIDE SHAFT      | DEMI-ESSIEU ARRIER | SEMIEJE TRASERO    | 1434-27-01-02<br>8267-RECHTS |     |
| 4        | 339 2346 | 1          | HINTERACHSHAELFTE | SIDE SHAFT      | DEMI-ESSIEU ARRIER | SEMIEJE TRASERO    | 1434-27-01-03<br>8195-LINKS  |     |
| 5        | 339 2375 | 2          | LAGERGEHAEUSE     | BEARING HOUSING | BOITIER DE PALIER  | CAJA SOPORTE       | 1435-27-03-05                |     |
| 6        | 110 9074 | 2          | RILLENKUGELLAGER  | BALL BEARING    | ROUL RAINURE BILLE | COJ.BOLAS FIJO     | 6211 DIN 625                 | 01  |
| 7        | 116 0854 | 2          | WELLENDICHRING    | SHAFT SEAL      | JOINT D ARBRE      | ANILLO PERMET-EJE  | S 65X45X33 H 2540-NI         | 01  |
| 10       | 339 2087 | 16         | SKT-PASSSCHRAUBE  | FITTED BOLT     | VIS AJUST 6 PANS   | TORN-HEX-CALIBR.   | 1424-27-01-13                |     |
| 11       | 339 2378 | 2          | ABDECKELECH       | COVER PLATE     | TOLE RECOUVREMENT  | CHAPA RECUPERPIEN. | 1435-27-01-24                |     |
| 12       | 338 7606 | 2          | DRUCKRING         | THRUST RING     | BAGUE DE BUTEE     | ANILLO PRESION     | 1124-27-01-09                |     |
| 13       | 332 7796 | 12         | SCHRAUUE          | SCREW/BOLT      | VIS/BOULON         | TORNILLO           | 524 697 4                    |     |
| 14       | 112 3546 | 12         | KUGELBENDMUTTER   | SHOULDER NUT    | ECROU COLLET SPHER | TUERK-COLLAR-ESFER | A18 DIN74361-63 V2KC         |     |
| 15       | 339 2377 | 08         | BEILAGE           | SHIM            | CALE               | SUPLEMENTO         | 1435-27-01-23                |     |
| 17       | 238 1111 | 1          | TRAGROHR          | SUPPORT TUBE    | TROMPETTE          | TROMPETA EJE       | 8267-RECHTS                  |     |
| 18       | 238 1112 | 1          | TRAGROHR          | SUPPORT TUBE    | TROMPETTE          | TROMPETA EJE       | 8195-LINKS                   |     |
| 19       | 111 2687 | 12         | SECHSKANTSCHRAUBE | HEX.BOLT        | VIS 6 PANS         | TORNILLO HEXAGONAL | M16X 40 DIN 932-M 8.8 A4C    |     |
| 20       | 111 2693 | 4          | SECHSKANTSCHRAUBE | HEX.BOLT        | VIS 6 PANS         | TORNILLO HEXAGONAL | M16X45 DIN 933-M8-8-A4C      |     |

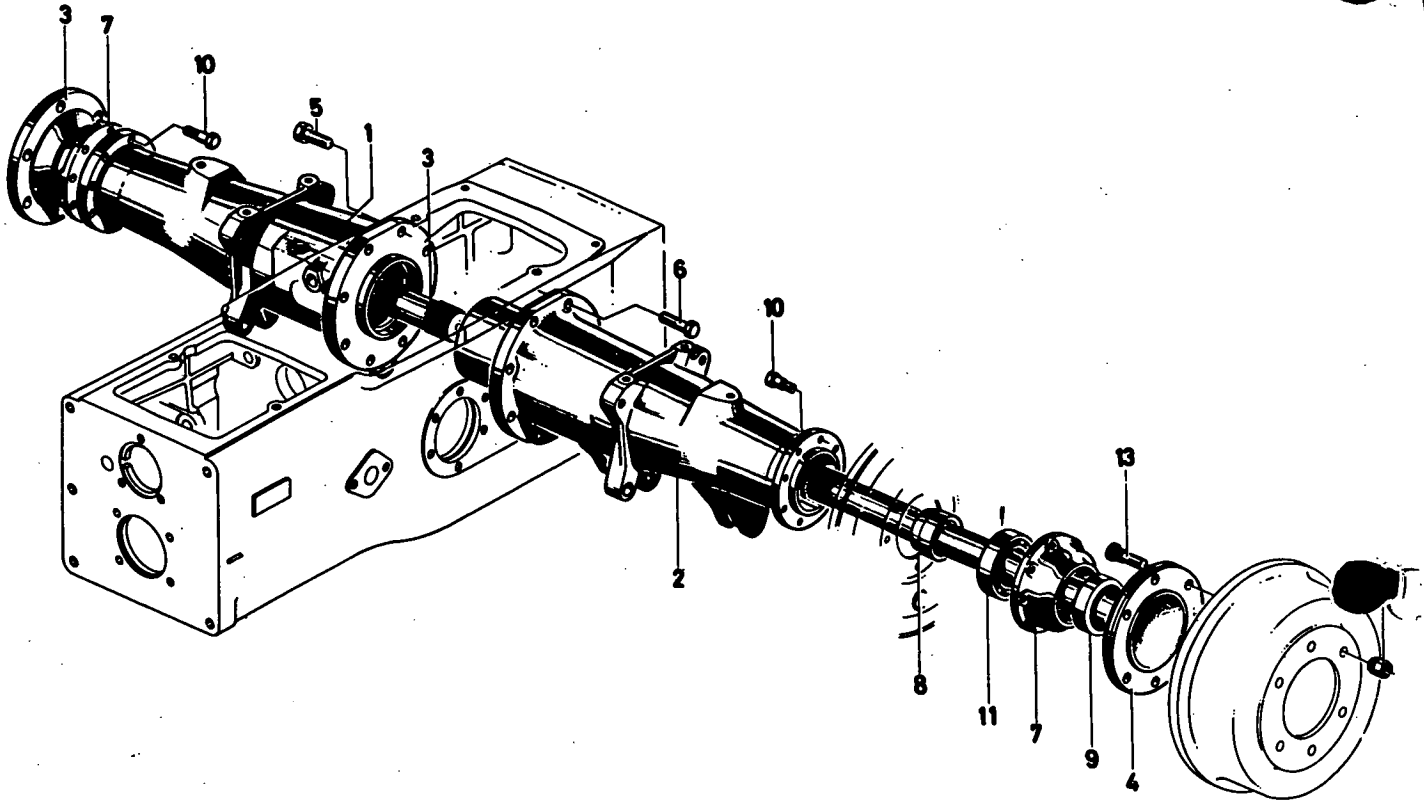

1434-27 500 5351

| Bild Nr. | Teil-Nr. | Stück-Zahl | Deutsch           | English         | Français           | Español            | Nummer/Bemerkung          | ETK |
|----------|----------|------------|-------------------|-----------------|--------------------|--------------------|---------------------------|-----|
| 1        | 233 2895 | 1          | TRAGROHR          | SUPPORT TUBE    | TROMPETTE          | TROMPETA EJE       | 8267-RECHTS               |     |
| 2        | 233 2893 | 1          | TRAGROHR          | SUPPORT TUBE    | TROMPETTE          | TROMPETA EJE       | 8195-LINKS                |     |
| 3        | 233 5947 | 1          | HINTERACHSHAELFTE | SIDE SHAFT      | DENI-ESSIEU ARRIER | SEÑEJE TRASERO     | 8267-RECHTS               |     |
| 4        | 233 5946 | 1          | HINTERACHSHAELFTE | SIDE SHAFT      | DENI-ESSIEU ARRIER | SEÑEJE TRASERO     | 8195-LINKS                |     |
| 5        | 111 2631 | 4          | SECHSKANTSCHRAUBE | HEX-BOLT        | VIS 6 PANS         | TORNILLO HEXAGONAL | M14X 45 DIN 933-M 8-8 A9C |     |
| 6        | 111 2624 | 12         | SECHSKANTSCHRAUBE | HEX-BOLT        | VIS 6 PANS         | TORNILLO HEXAGONAL | M14X 40 DIN 933-M 8-8 A9C |     |
| 7        | 339 2553 | 2          | LAGERGEHAEUSE     | BEARING HOUSING | BOITIER DE PALIER  | CAJA SOPORTE       | 1445-27-01-22             |     |
| 8        | 339 2547 | 2          | RING              | RING            | BAGUE/ANNEAU       | ANILLO             | 1445-27-01-08             |     |
| 9        | 116 0857 | 2          | WELLENDICHTRING   | SHAFT SEAL      | JOINT D ARBRE      | ANILLO HERMET-EJE  | 5 80X100 X12 H 2940-MI    | 01  |
| 10       | 339 2067 | 16         | SKT-PASSSCHRAUBE  | FITTED BOLT     | VIS AJUST 6 PANS   | TORN-HEX-CALIBR-   | 1424-27-01-13             |     |
| 11       | 110 9070 | 2          | RILLENKUGELLAGER  | BALL BEARING    | ROUL RAINURE BILLE | COJ-BOLAS FIJO     | 6214 DIN 625              | 01  |
| 12       | 112 3546 | 12         | KUGELBUNDHUTTER   | SHOULDER NUT    | ECROU COLLET SPHER | TUERC-COLLAR-ESFER | A18 DIN74361-65 VZKC      |     |
| 13       | 332 7796 | 12         | SCHRAUBE          | SCREW/BOLT      | VIS/BOULON         | TORNILLO           | 524 697 H                 |     |

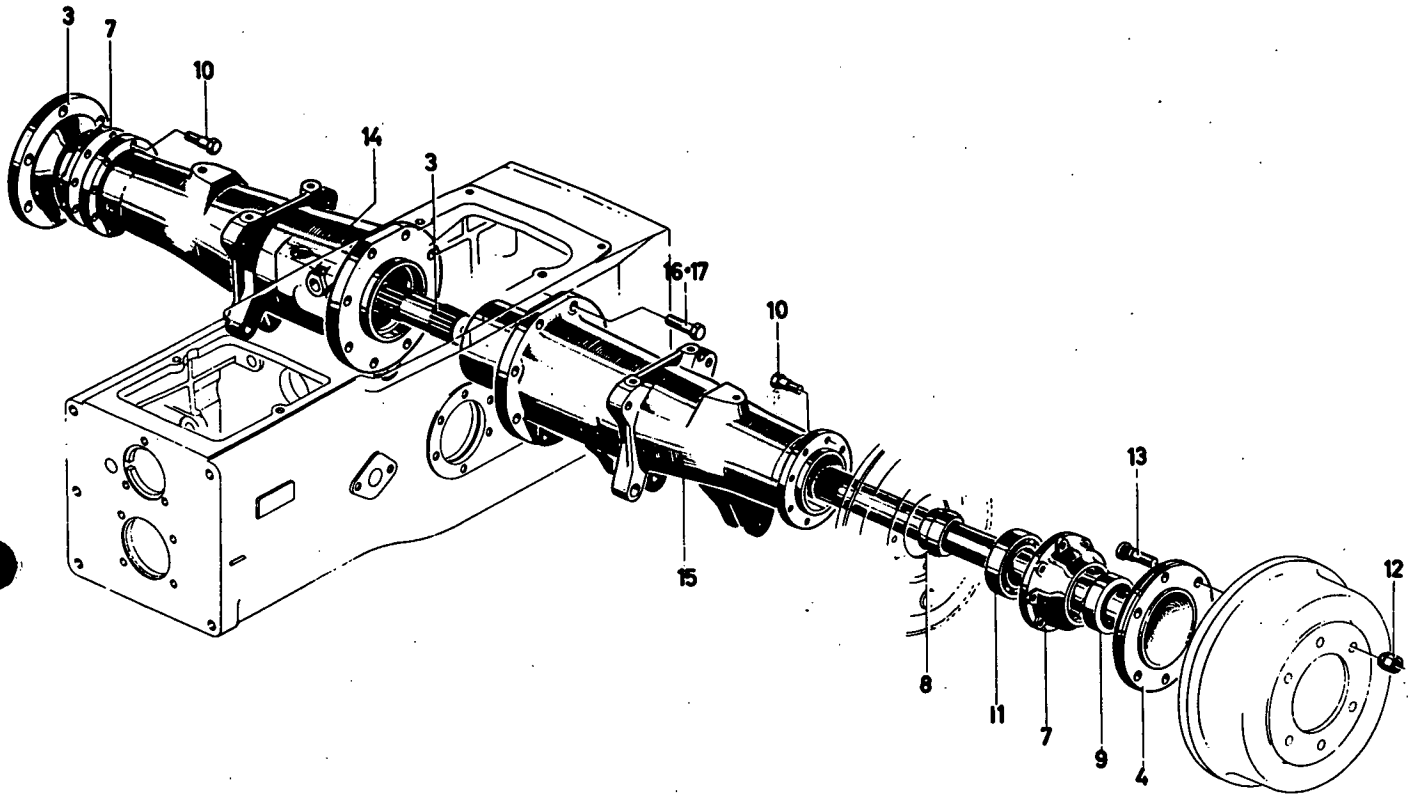

| Bild Nr. | Teil-Nr. | Stück-Zahl | Deutsch           | English         | Français           | Español            | 1434-27 502 0208<br>Nummer/Bemerkung | ETK |
|----------|----------|------------|-------------------|-----------------|--------------------|--------------------|--------------------------------------|-----|
| 3        | 233 5947 | 1          | HINTERACHSHAELFTE | SIDE SHAFT      | DEMI-ESSIEU ARRIER | SEMIEJE TRASERO    | 8267-RECHTS                          |     |
| 4        | 233 5948 | 1          | HINTERACHSHAELFTE | SIDE SHAFT      | DEMI-ESSIEU ARRIER | SEMIEJE TRASERO    | 8195-LINKS                           |     |
| 7        | 339 2553 | 2          | LAGERGEHAUESE     | BEARING HOUSING | BOITIER DE PALIER  | CAJA SOPORTE       | 1445-27-01-22                        |     |
| 8        | 339 2547 | 2          | BRUCKRING         | THRUST RING     | BAGUE DE BUTEE     | ANILLO PRESSION    | 1445-27-01-08                        |     |
| 9        | 116 0857 | 2          | WELLENDICHTRING   | SHAFT SEAL      | JOINT D ARBRE      | ANILLO HERMET-EJE  | S 80X100 X12 H 2940-NI               | 01  |
| 10       | 339 2087 | 16         | PASSSCHRAUBE      | FITTED BOLT     | VIS D AJUSTAGE     | TORN-VAST-CALIBRAD |                                      |     |
| 11       | 110 9090 | 2          | RILLENKUGELLAGER  | BALL BEARING    | ROUL RAINURE BILLE | COJ-BOLAS FIJO     | 6214 DIN 625                         | 01  |
| 12       | 112 3546 | 12         | KUGELBUNDMUTTER   | SHOULDER NUT    | ECROU COLLET SPHER | TUERC-COLLAR-ESFER | A16 DIN74363- 8 A4C                  |     |
| 13       | 332 7796 | 12         | SCHRAUBE          | SCREW/BOLT      | VIS/BOULON         | TORNILLO           |                                      |     |
| 14       | 238 1111 | 1          | TRAGROHR          | SUPPORT TUBE    | TROMPETTE          | TROMPETA EJE       | 8267-RECHTS                          |     |
| 15       | 238 1112 | 1          | TRAGROHR          | SUPPORT TUBE    | TROMPETTE          | TROMPETA EJE       | 8195-LINKS                           |     |
| 16       | 111 2687 | 12         | SECHSKANTSCHRAUBE | HEX-BOLT        | VIS 6 PANS         | TORNILLO HEXAGONAL | M16X 40 DIN 933-M 8-8 A4C            |     |
| 17       | 111 2693 | 4          | SECHSKANTSCHRAUBE | HEX-BOLT        | VIS 6 PANS         | TORNILLO HEXAGONAL | M16X 95 DIN 933-M 8-8 A4C            |     |

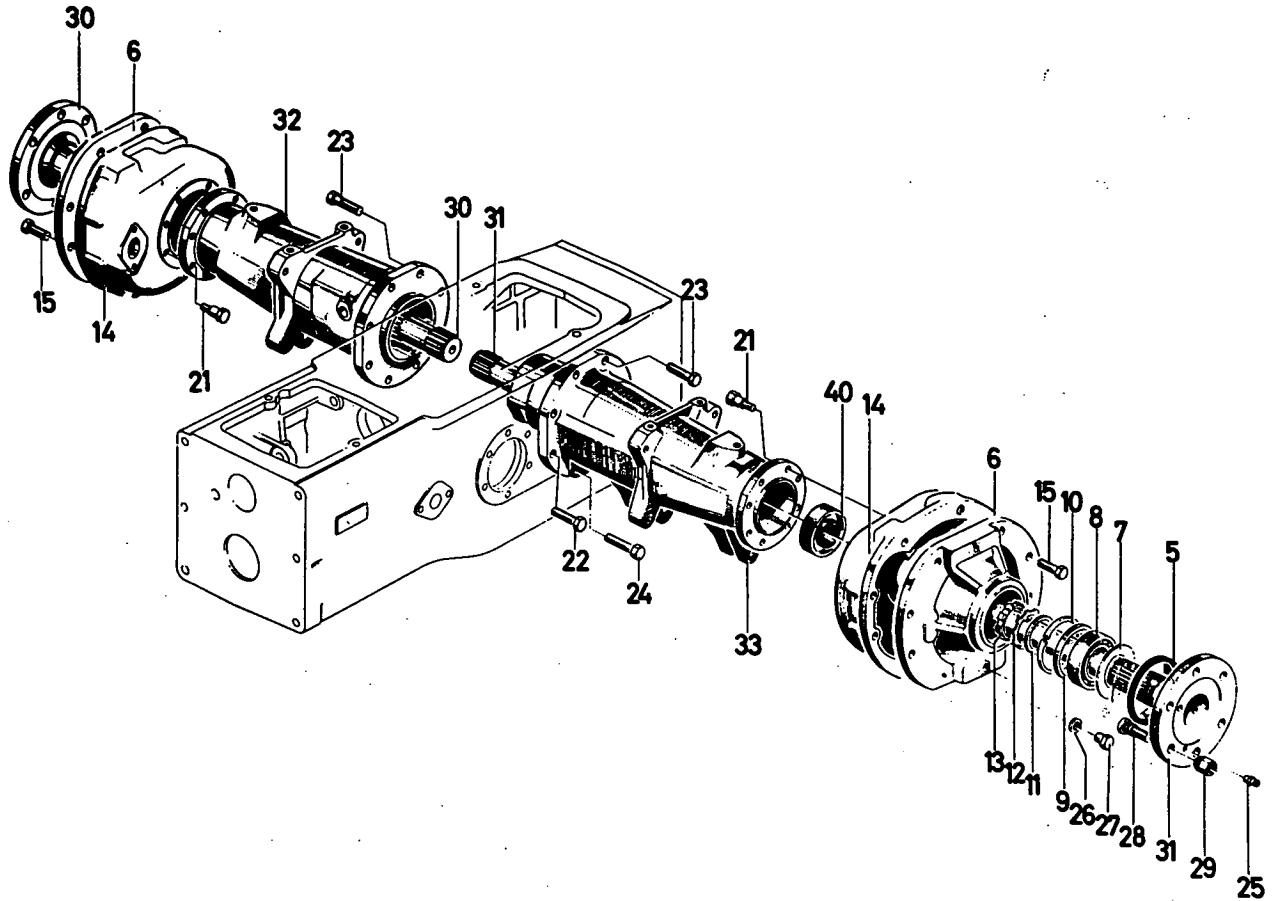

| Bld Nr. | Teil-Nr. | Stück-Zahl | Deutsch            | English         | Français           | Español            | 1446-27 502 0205<br>Nummer/Bemerkung | ETK |
|---------|----------|------------|--------------------|-----------------|--------------------|--------------------|--------------------------------------|-----|
| 5       | 231 5962 | 2          | DICHRING           | WASHER          | BAGUE D ETANCHEITE | ANILLO DE JUNTA    |                                      | 01  |
| 6       | 232 6077 | 2          | BECKEL             | COVER           | COUVERCLE          | TAPA               |                                      |     |
| 7       | 116 0133 | 4          | AX-WAELZLG-DICHTRS | BEARING SEAL    | BAGUE-JOINT ROUL.  | ARO HERMET-AXIAL   | 125X79.5 H 2945                      |     |
| 8       | 230 9517 | 2          | RILLENKUGELLAGER   | BALL BEARING    | ROUL RAINURE BILLE | COJ-BOLAS FIJO     |                                      | 01  |
| 9       | 230 2258 | 2          | SCHEIBE            | DISC/PANE/PLATE | RONDELLE/DISQUE    | DISCO              |                                      |     |
| 10      | 110 7666 | 2          | SICHERUNGSRING     | CIRCLIP         | CIRCLIP            | CIRCLIP            | 125X4 DIN 972                        |     |
| 11      | 230 2259 | 2          | ABSTANDRING        | SPACER RING     | BAGUE ECARTEMENT   | ARO DISTANCIARIO   |                                      |     |
| 12      | 112 0677 | 2          | SICHERUNGSBLECH    | LOCKING PLATE   | TOLE DE SECURITE   | CHAPA SEGURIDAD    | A 70DIN70952                         |     |
| 13      | 116 7169 | 2          | MUTNUTTER          | GROOVED NUT     | ECROU RAINURE      | TUERCA RAMURADA    | M 70X1.5H 2174                       |     |
| 14      | 232 6075 | 2          | GEHAEUSE           | HOUSING/CASE    | CARTER/BOITIER     | CAJA/BLOQUE/CUERPO |                                      |     |
| 15      | 111 2538 | 16         | SECHSKANTSCHRAUBE  | HEX-BOLT        | VIS 6 PANS         | TORNILLO HEXAGONAL | M 12X35 DIN 933-M8.8-A4C             |     |
| 21      | 339 2087 | 16         | SKT-PASSSCHRAUBE   | FITTED BOLT     | VIS AJUST 6 PANS   | TORN-HEX-CALIBR.   | 1424-27-01-13                        |     |
| 22      | 111 2624 | 8          | SECHSKANTSCHRAUBE  | HEX-BOLT        | VIS 6 PANS         | TORNILLO HEXAGONAL | M 14X40 DIN 933-M8.8-A4C             |     |
| 23      | 111 2631 | 4          | SECHSKANTSCHRAUBE  | HEX-BOLT        | VIS 6 PANS         | TORNILLO HEXAGONAL | M14X 45 DIN 933-M 8.8 A4C            |     |
| 24      | 111 2636 | 4          | SECHSKANTSCHRAUBE  | HEX-BOLT        | VIS 6 PANS         | TORNILLO HEXAGONAL | M14X50 DIN 933-M8.8-A4C              |     |
| 25      | 116 8225 | 2          | KEGELSCHMIERNIPPEL | LUBE FITTING    | GRAISSEUR CONIQUE  | ENGRASADOR CONICO  | SA 8H 3360                           | 01  |
| 26      | 111 8673 | 2          | DICHRING           | WASHER          | BAGUE D ETANCHEITE | ANILLO DE JUNTA    | A 14 X 20 DIN 7603-CU                |     |
| 27      | 112 2351 | 2          | VERSCHLUSSSCHRAUBE | SCREW PLUG      | BOUCHON FILETE     | TAPON ROSCADO      | M14X1.5 DIN 910-M 8.8                |     |
| 28      | 339 3268 | 12         | SCHRAUBE           | SCREW/BOLT      | VIS/BOULON         | TORNILLO           | 1455-27-02-18                        |     |
| 29      | 112 3546 | 12         | KUGELBUNDMUTTER    | SHOULDER NUT    | ECROU COLLET SPHER | TUERC-COLLAR-ESFER | A18 DIN74361-6S VZKC                 |     |
| 30      | 231 5923 | 1          | STECKVELLE         | PLUG-IN SHAFT   | DEMI-ARBRE FLOTT   | EJE ENCHUFE        | 8267-RECHTS                          |     |
| 31      | 231 5925 | 1          | STECKVELLE         | PLUG-IN SHAFT   | DEMI-ARBRE FLOTT   | EJE ENCHUFE        | 8195-LINKS                           |     |
| 32      | 232 6082 | 1          | TRAGROHR           | SUPPORT TUBE    | TROMPETTE          | TROMPETA EJE       | 8267-RECHTS                          |     |
| 33      | 232 6081 | 1          | TRAGROHR           | SUPPORT TUBE    | TROMPETTE          | TROMPETA EJE       | 8195-LINKS                           |     |
| 40      | 237 2170 | 2          | RADIALDICHRING     | RADIAL SEAL     | BAGUE-JOINT RADIAL | ANIL-JUNTA RADIAL  |                                      | 01  |

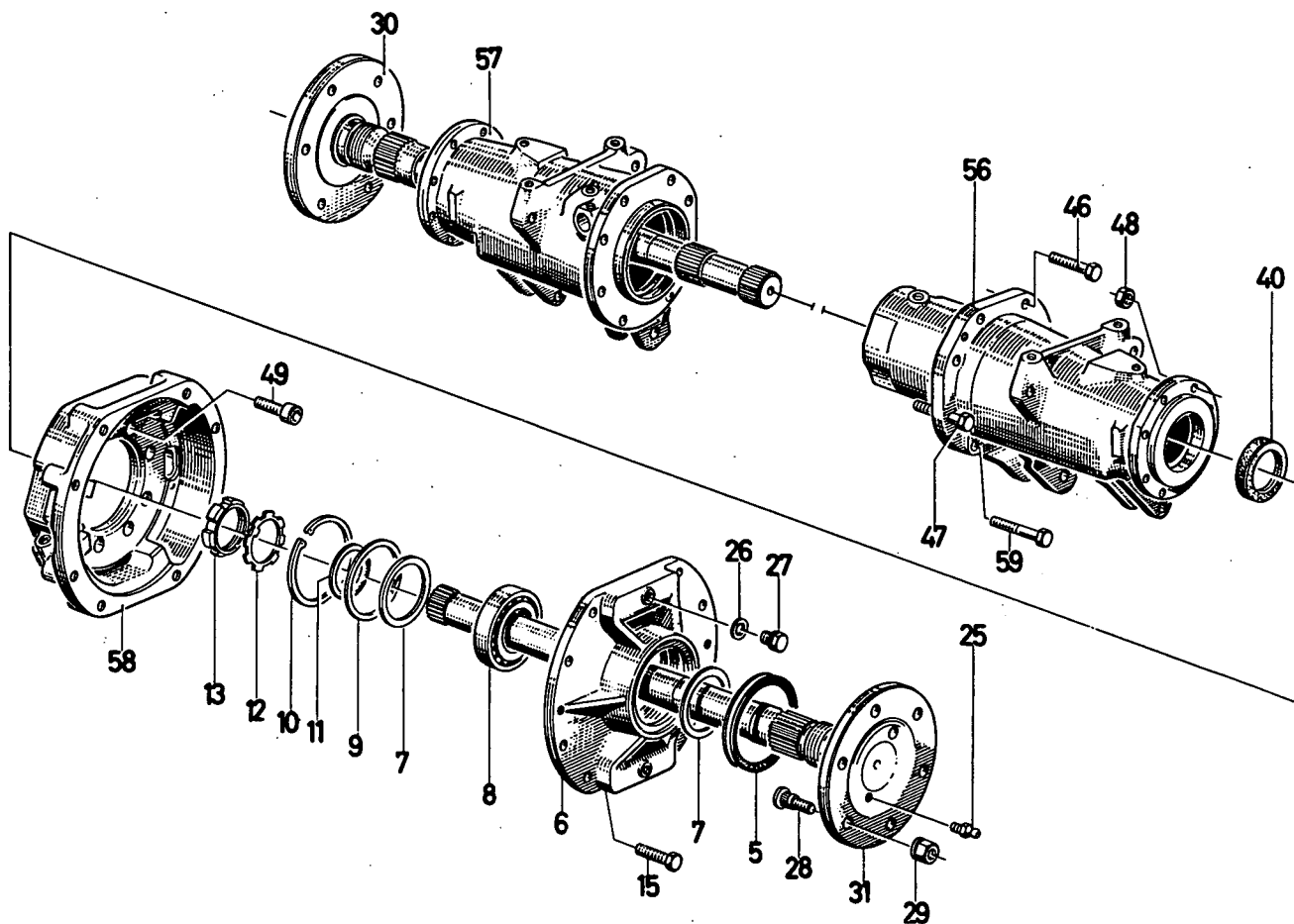

| Bld. Nr. | Teil-Nr. | Stück-Zahl | Deutsch            | English           | Français           | Español             | 1446-27 502 0206<br>Nummer/Bemerkung | ETK |
|----------|----------|------------|--------------------|-------------------|--------------------|---------------------|--------------------------------------|-----|
| 5        | 231 5962 | 2          | DICHRING           | WASHER            | BAGUE D ETANCHEITE | ANILLO DE JUNTA     |                                      | 01  |
| 6        | 232 6077 | 2          | DECKEL             | COVER             | COUVERCLE          | TAPA                |                                      |     |
| 7        | 116 0133 | 4          | AX-WÄELZLG-DICHTRG | BEARING SEAL      | BAGUE-JOINT ROUL.  | ARO HERMET-AXIAL    | 125X79.5 H 2945                      |     |
| 8        | 230 9517 | 2          | RILLENKUGELLAGER   | BALL BEARING      | ROUL RAINURE BILLE | COJ-BOLAS FIJO      |                                      | 01  |
| 9        | 230 2258 | 2          | SCHEIBE            | DISC/PANE/PLATE   | RONDELLE/DISQUE    | DISCO               |                                      |     |
| 10       | 110 7866 | 2          | SICHERUNGSRING     | CIRCLIP           | CIRCLIP            | CIRCLIP             | 125X4 DIN 472                        |     |
| 11       | 230 2259 | 2          | ABSTANDRING        | SPACER RING       | BAGUE ECARTENENT   | ARO DISTANCIARIO    |                                      |     |
| 12       | 112 0677 | 2          | SICHERUNGSBLECH    | LOCKING PLATE     | TOLE DE SECURITE   | CHAPA SEGURIDAD     | A 70DIN70952                         |     |
| 13       | 116 7169 | 2          | NUTMUTTER          | GROOVED NUT       | ECROU RAINURE      | TUERCA RANURADA     | M 70X1.5H 2174                       |     |
| 15       | 111 2538 | 16         | SECHSKANTSCHRAUBE  | HEX-BOLT          | VIS 6 PANS         | TORNILLO HEXAGONAL  | M 12X35 DIN 933-M8.8-A4C             |     |
| 25       | 116 8225 | 2          | KEGELSCHMIERNIPPEL | LUBE FITTING      | GRAISSEUR CONIQUE  | ENGRASADOR CONICO   | SA 8H 3360                           | 01  |
| 26       | 111 8693 | 2          | DICHRING           | WASHER            | BAGUE D ETANCHEITE | ANILLO DE JUNTA     | A 14 X 20 DIN 7603-CU                |     |
| 27       | 112 2351 | 2          | VERSCHLUSSSCHRAUBE | SCREW PLUG        | BOUCHON FILETE     | TAPON ROSCADO       | M14X1.5 DIN 910-M 8.8                |     |
| 28       | 337 3268 | 12         | SCHRAUBE           | SCREW/BOLT        | VIS/BOULON         | TORNILLO            | 1455-27-02-18                        |     |
| 29       | 112 3546 | 12         | KUGELBUNDMUTTER    | SHOULDER NUT      | ECROU COLLET SPHER | TUERCO-COLLAR-ESFER | A18 DIN74361-65 VZKC                 |     |
| 30       | 231 5923 | 1          | STECKWELLE         | PLUG-IN SHAFT     | DEMI-ARBRE FLOTT   | EJE ENCHUFE         | 8267-RECHTS                          |     |
| 31       | 231 5925 | 1          | STECKWELLE         | PLUG-IN SHAFT     | DEMI-ARBRE FLOTT   | EJE ENCHUFE         | B195-LINKS                           |     |
| 40       | 237 2170 | 2          | RADIALDICHRING     | RADIAL SEAL       | BAGUE-JOINT RADIAL | ANIL-JUNTA RADIAL   |                                      | 01  |
| 46       | 111 2687 | 8          | SECHSKANTSCHRAUBE  | HEX-BOLT          | VIS 6 PANS         | TORNILLO HEXAGONAL  | M16X 40 DIN 933-M 8.8 A4C            |     |
| 47       | 111 2701 | 4          | SECHSKANTSCHRAUBE  | HEX-BOLT          | VIS 6 PANS         | TORNILLO HEXAGONAL  | M16X55 DIN 933-M8.8-A4C              |     |
| 48       | 111 2858 | 16         | SECHSKANTMUTTER    | HEX-NUT           | ECROU 6 PANS       | TUERCA HEXAGONAL    | M12 DIN 934 M8 A4C                   |     |
| 49       | 237 8881 | 16         | ZYLINDERSCHRAUBE   | CHEESE-HEAD SCREW | VIS TETE CYLINDR.  | TORN-CBZA-CILINDR.  |                                      |     |
| 56       | 237 8921 | 1          | TRAGROHR           | SUPPORT TUBE      | TROMPETTE          | TROMPETA EJE        | B195-LINKS                           |     |
| 57       | 237 8916 | 1          | TRAGROHR           | SUPPORT TUBE      | TROMPETTE          | TROMPETA EJE        |                                      |     |
| 58       | 237 8924 | 2          | GEHAEUSE           | HOUSING/CASE      | CARTER/BOITIER     | CAJA/BLOQUE/CUERPO  | 8767 RECHTS                          |     |
| 59       | 111 2693 | 4          | SECHSKANTSCHRAUBE  | HEX-BOLT          | VIS 6 PANS         | TORNILLO HEXAGONAL  | M16X45 DIN 933-M8.8-A4C              |     |



ANGETRIEBENE VORERACHSE  
DRIVEN FRONT AXLE  
ESSIEU AV MOTEUR  
EJE DELANTERO CON ACCIONAMIENTO

1005-28 500 4280

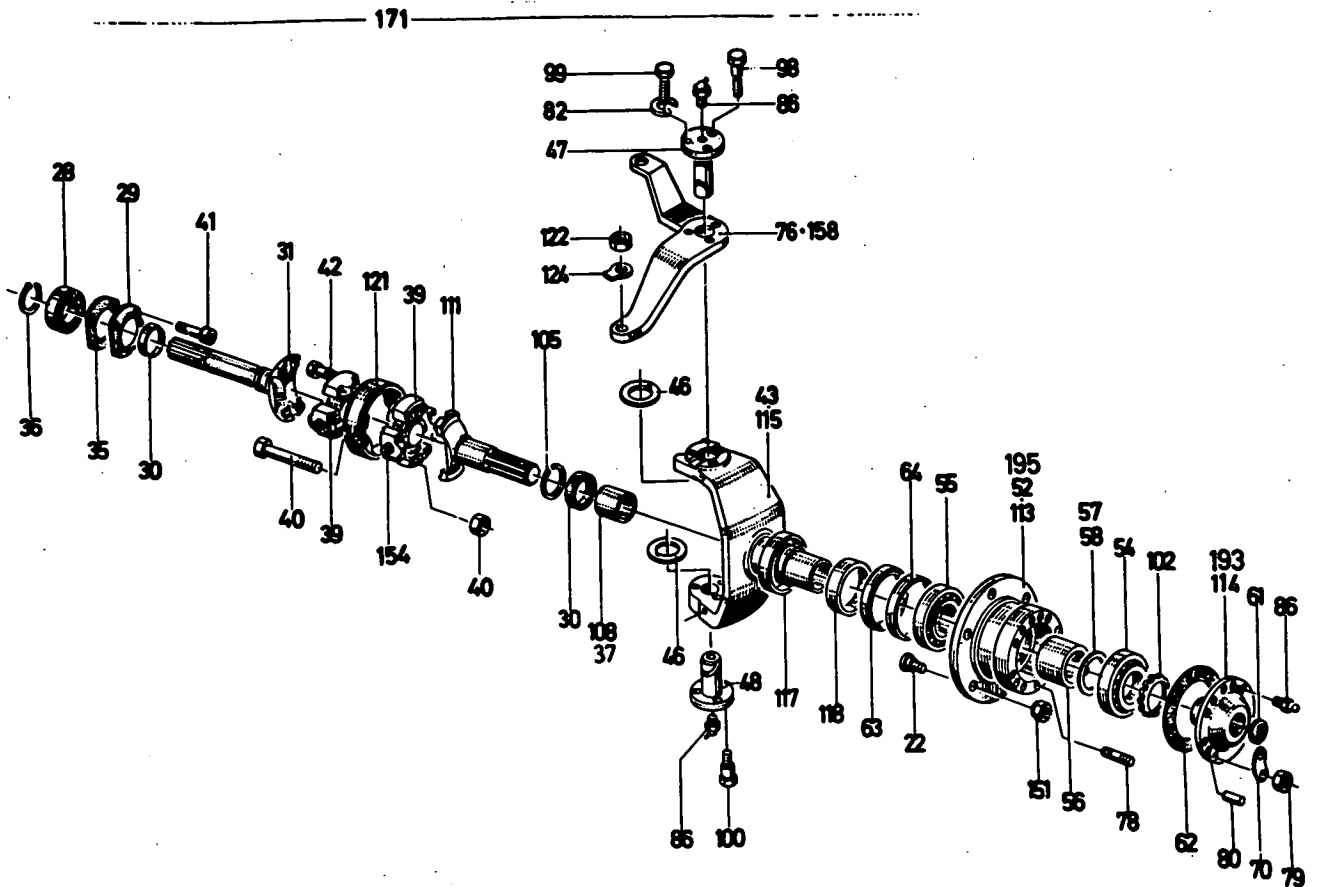
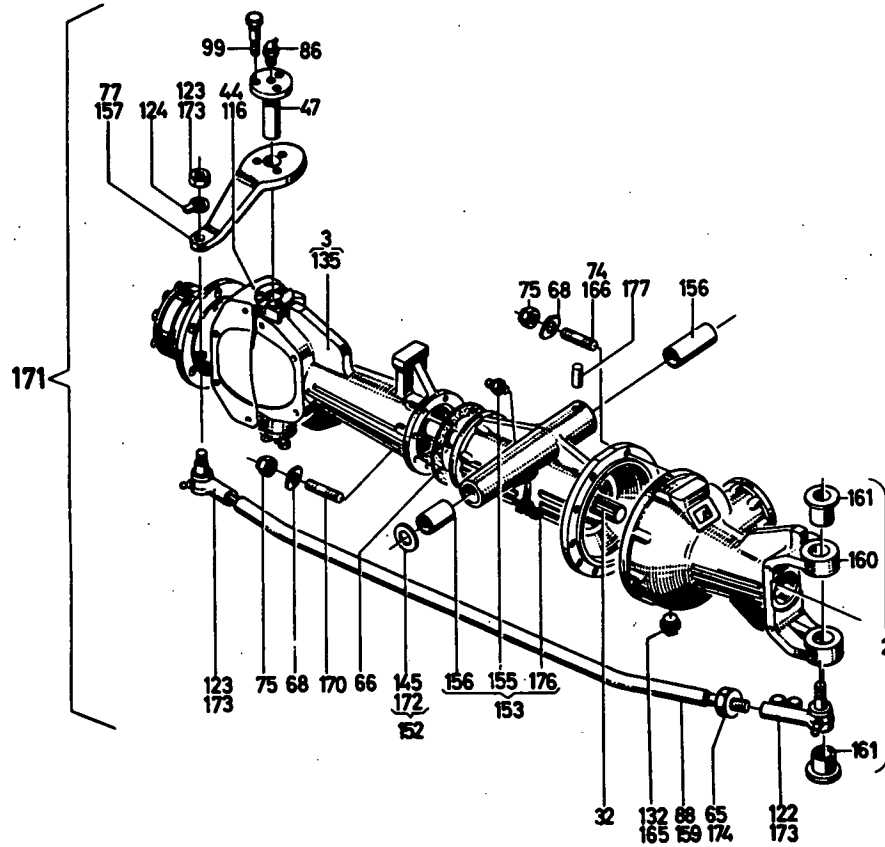



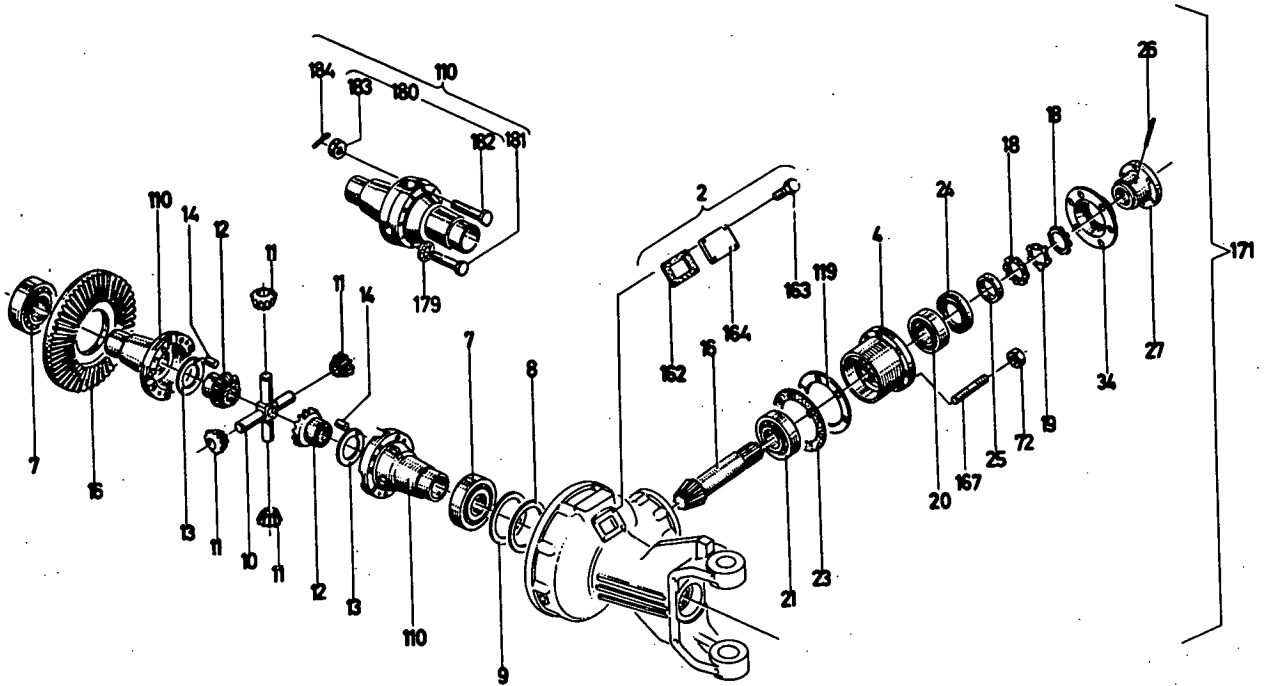

| Bild<br>Nr. | Teil-Nr. | Stück-<br>Zahl | 1005-28 500 4280   |                    |                    |                     | Nummer/Bemerkung  | ETK |
|-------------|----------|----------------|--------------------|--------------------|--------------------|---------------------|-------------------|-----|
|             |          |                | Deutsch            | English            | Français           | Español             |                   |     |
| 2           | 231 5784 | 1              | ACHSBRUECKE        | AXLE BRACKET       | PONT ESSIEU        | PUNTE EJE           | 8348.VORN-LINKS   |     |
| 3           | 231 5782 | 1              | ACHSBRUECKE        | AXLE BRACKET       | PONT ESSIEU        | PUNTE EJE           | 8348.VORN-RECHTS  |     |
| 4           | 231 1124 | 1              | LAGERGEHAEUSE      | BEARING HOUSING    | BOITIER DE PALIER  | CAJA SOPORTE        |                   |     |
| 7           | 111 0005 | 2              | KEGELROLLENLAGER   | TAP-ROLLER BEARING | ROULEN A ROUL CON  | COJ-RODIL-CONICOS   | 32212 DIN 720     | 01  |
| 8           | 231 1154 | 1              | BEILAGE            | SHIM               | CALE               | SUPLEMENTO          |                   |     |
| 9           | 231 1153 | 2              | BEILAGE            | SHIM               | CALE               | SUPLEMENTO          |                   |     |
| 10          | 231 1174 | 1              | KREUZZAPPEN        | SPIDER             | TENON EN CROIX     | MUNON CRUCETA       |                   |     |
| 11          | 231 1148 | 4              | KEGELRAD           | BEVEL GEAR         | ENGREN CONIQUE     | RUEDA CONICA        | Z 10              |     |
| 12          | 231 1141 | 2              | KEGELRAD           | BEVEL GEAR         | ENGREN CONIQUE     | RUEDA CONICA        | Z 16              |     |
| 13          | 237 8939 | 2              | ANLAUFSCHIEBE      | STOP WASHER        | DISQUE BUTEE       | ARANDELA TOPE       |                   |     |
| 14          | 231 1180 | 2              | ZYLINDERSTIFT      | PARALLEL PIN       | GOUPILLE CYLINDR.  | PERNO CILINDRICO    |                   |     |
| 16          | 237 8968 | 1              | KEGELRAD           | BEVEL GEAR         | ENGREN CONIQUE     | RUEDA CONICA        | M-RITZEL          |     |
| 18          | 112 0609 | 2              | MUTTER             | GROOVED NUT        | ECROU RAINURE      | TUERCA RANURADA     | M 42X1,5 DIN70852 | 01  |
| 19          | 231 1166 | 1              | SICHERUNGSBLECH    | LOCKING PLATE      | TOLE DE SECURITE   | CHAPA SEGURIDAD     |                   | 01  |
| 20          | 110 1909 | 1              | KEGELROLLENLAGER   | TAP-ROLLER BEARING | ROULEN A ROUL CON  | COJ-RODIL-CONICOS   | 32209 DIN 720     | 01  |
| 21          | 110 9981 | 1              | KEGELROLLENLAGER   | TAP-ROLLER BEARING | ROULEN A ROUL CON  | COJ-RODIL-CONICOS   | 30309 DIN 720     | 01  |
| 22          | 231 1164 | 12             | RADBEFESTIG.BOLZEN | WHEEL PIN          | BOULON FIX DE ROUE | BULON FIJAC-RUEDA   |                   |     |
| 23          | 231 1195 | 1              | BEILAGE            | SHIM               | CALE               | SUPLEMENTO          |                   |     |
| 24          | 231 1118 | 1              | DICHRING           | WASHER             | BAGUE D ETANCHEITE | ANILLO DE JUNTA     |                   | 01  |
| 25          | 231 1171 | 1              | ABSTANDRING        | SPACER RING        | BAGUE ECARTEMENT   | ARO DISTANCIARIO    |                   |     |
| 26          | 231 1173 | 1              | BOLZEN             | PIN/BOLT/STUD      | BOULON/AXE         | BULON               |                   |     |
| 27          | 231 1149 | 1              | ANTRIEBSFLANSCH    | DRIVE FLANGE       | BRIDE DE COMMANDE  | BRIDA ACCIONAMIENTO |                   |     |
| 28          | 110 8981 | 2              | RILLENKUGELLAGER   | BALL BEARING       | ROUL RAINURE BILLE | COJ-BOLAS FIJO      | 6009 DIN 625      |     |

| Bld Nr. | Teil-Nr. | Stück-Zahl | Deutsch           | English            | Français           | Español            | Nummer/Bemerkung   | ETK |
|---------|----------|------------|-------------------|--------------------|--------------------|--------------------|--|-----|
| 29      | 231 1179 | 2          | FLANSCH           | FLANGE             | BRIDE/COLLET       | BRIDA              |  |     |
| 30      | 231 1160 | 4          | DICHTRING         | WASHER             | BAGUE D ETANCHEITE | ANILLO DE JUNTA    |  | 01  |
| 31      | 231 1140 | 1          | GELENKWELLE       | JOINT SHAFT        | ARBRE A CARDAN     | EJE ARTICULADO     | 8195-LINKS   |     |
| 32      | 231 1137 | 1          | GELENKWELLE       | JOINT SHAFT        | ARBRE A CARDAN     | EJE ARTICULADO     | 8267-RECHTS  |     |
| 34      | 231 1147 | 1          | SCHUTZKAPPE       | CAP                | CAPUCHON PROTECT   | SOMBRERETE PROTEC. |  |     |
| 35      | 231 1155 | 2          | DICHTUNG          | GASKET             | GARNITURE/JOINT    | JUNTA              |  | 01  |
| 36      | 110 7760 | 2          | SICHERUNGSRING    | CIRCLIP            | CIRCLIP            | CIRCLIP            | 45X1,75DIN 471   |     |
| 37      | 231 1157 | 2          | BUCHSE            | BUSH               | DOUILLE            | CASQUILLO          | 8025-BIS ACHSEN-NO.1252<br>8002-AB ACHSEN-NO.1253 POS108                         |     |
| 39      | 231 1144 | 4          | KREUZGELENK       | UNIVERSAL JOINT    | JOINT A CROISILLON | ARTICULAC-CRUCETA  |  |     |
| 40      | 231 1170 | 8          | SECHSKANTSCHRAUBE | HEX-BOLT           | VIS 6 PANS         | TORNILLO HEXAGONAL |  |     |
| 41      | 231 1163 | 8          | ZYLINDERSCHRAUBE  | CHEESE-HEAD SCREW  | VIS TETE CYLINDR.  | TORN-CBZA-CILIND.  |  |     |
| 42      | 231 1164 | 16         | SECHSKANTSCHRAUBE | HEX-BOLT           | VIS 6 PANS         | TORNILLO HEXAGONAL |  |     |
| 43      | 231 1127 | 1          | NABENTRAEGER      | HUB CARRIER        | SUPPORT DE ROYEU   | PORTA-CUBO         | 8195-LINKS<br>8025-BIS ACHSEN-NO.1252<br>8002-AB ACHSEN-NO.1253-1710<br>POS-950  |     |
| 44      | 231 1128 | 1          | NABENTRAEGER      | HUB CARRIER        | SUPPORT DE ROYEU   | PORTA-CUBO         | 8267-RECHTS<br>8025-BIS ACHSEN-NO.1252<br>8002-AB ACHSEN-NO.1253-1710<br>POS-951 |     |
| 46      | 231 1156 | 4          | SCHEIBE           | DISC/PANE/PLATE    | RONDELLE/DISQUE    | DISCO              |  |     |
| 47      | 231 1197 | 2          | LAGERBOLZEN       | PIVOT PIN          | AXE SUPPORT        | BULON SOPORTE      | 8242-08EN  |     |
| 48      | 231 1198 | 2          | LAGERBOLZEN       | PIVOT PIN          | AXE SUPPORT        | BULON SOPORTE      | 8324-UNTEN   |     |
| 52      | 231 1131 | 2          | NABE              | HUB                | ROYEU              | CUBO               | 8025-BIS ACHSEN-NO.1710<br>8002-AB ACHSEN-NO.1711 POS113                         |     |
| 54      | 110 9763 | 2          | KEGELROLLENLAGER  | TAP-ROLLER BEARING | ROULEM A ROUL COM  | COJ-RODIL-COMICOS  | 30213 DIN 720  | 01  |
| 55      | 110 9764 | 2          | KEGELROLLENLAGER  | TAP-ROLLER BEARING | ROULEM A ROUL COM  | COJ-RODIL-COMICOS  | 30214 DIN 720  | 01  |
| 56      | 231 1203 | 2          | ABSTANDROHR       | SPACER TUBE        | TUBE ECARTEMENT    | TUBO DISTANCIARIO  |  |     |
| 57      | 231 1168 | 2          | BEILAGE           | SHIM               | CALE               | SUPLEMENTO         | A 0,5MM  |     |
| 58      | 231 1167 | 4          | BEILAGE           | SHIM               | CALE               | SUPLEMENTO         | A 0,2MM  |     |
| 61      | 231 1159 | 2          | BECKEL            | COVER              | COUVERCLE          | TAPA               |  |     |
| 62      | 231 1193 | 2          | DICHTUNG          | GASKET             | GARNITURE/JOINT    | JUNTA              |  | 01  |
| 63      | 231 1162 | 2          | DICHTRING         | WASHER             | BAGUE D ETANCHEITE | ANILLO DE JUNTA    |  | 01  |
| 64      | 231 1161 | 2          | ABSTANDRING       | SPACER RING        | BAGUE ECARTEMENT   | ARO DISTANCIARIO   |  |     |
| 65      | 231 1178 | IP         | SECHSKANTMUTTER   | HEX-NUT            | ECROU 6 PANS       | TUERCA HEXAGONAL   | 8075-ERSETZT DURCH POS-174   |     |
| 66      | 231 1153 | 2          | DICHTUNG          | GASKET             | GARNITURE/JOINT    | JUNTA              |  | 01  |
| 68      | 110 6354 | 18         | SICHERUNGSBLECH   | LOCKING PLATE      | TOLE DE SECURITE   | CHAPA SEGURIDAD    | 13 DIN 93-ST VZKC  | 01  |
| 70      | 231 1170 | 6          | SICHERUNGSBLECH   | LOCKING PLATE      | TOLE DE SECURITE   | CHAPA SEGURIDAD    |  |     |
| 72      | 110 2659 | 6          | SECHSKANTMUTTER   | HEX-NUT            | ECROU 6 PANS       | TUERCA HEXAGONAL   | M10 DIN 934-M 8 A9C  |     |
| 74      | 231 1179 | 1          | BOLZENSCHRAUBE    | STUD               | BOULON             | TORN-VASTAGO       |  |     |
| 75      | 111 2870 | 18         | SECHSKANTMUTTER   | HEX-NUT            | ECROU 6 PANS       | TUERCA HEXAGONAL   | M12 X1,5 DIN 934-M10   | 03  |
| 76      | 231 1129 | 1          | LENKSPURHEBEL     | STEERING ARM       | LEV ATTAQUE FUSEE  | PALANCA BIELA ACOP | 8041-BEI ERSTMALIGEN ERSATZ<br>POS-157-159,173*174MITLIEFERN                     |     |
| 77      | 231 1134 | 1          | LENKHEBEL         | STEERING ARM       | LEVIER DE DIRECTIO | PALANCA DIRECCION  | 8041-BEI ERSTMALIGEN ERSATZ<br>POS-157-159,173*174MITLIEFERN                     |     |
| 78      | 231 1183 | 16         | STIFTSCHRAUBE     | STUD               | GOUJON             | ESPARRAGO          |  |     |
| 79      | 231 1174 | 16         | SECHSKANTMUTTER   | HEX-NUT            | ECROU 6 PANS       | TUERCA HEXAGONAL   |  |     |
| 80      | 231 1177 | 10         | ZYLINDERSTIFT     | PARALLEL PIN       | GOUPILLE CYLINDR.  | PERNO CILINDRICO   |  |     |
| 82      | 110 2799 | 32         | FEDERRING         | SPRING LOCKWASHER  | RONDELLE GROUER    | ARANDELA ELASTICA  | A 8 DIN 128 A9C  |     |

| Bld Nr. | Teil-Nr. | Stück-Zahl | Deutsch            | English         | Français              | Español            | Nummer/Bemerkung   | ETK |
|---------|----------|------------|--------------------|-----------------|-----------------------|--------------------|--|-----|
| 86      | 116 822b | 6          | SCHMIERNIPPEL      | LUBE FITTING    | RACCOR GRASSEUR       | NIPLE LUBRICACION  | SA10H 3360   |     |
| 88      | 231 1201 | 1          | SPURSTANGE         | TRACK ROD       | BARRE ACCOUPLEMENT    | BIELA ANCHO RODAD. | 8041.BEI ERSTMALIGEN ERSATZ<br>POS.157-159-173+174MITLIEFERN |     |
| 98      | 111 1325 | 2          | SECHSKANTSCHRAUBE  | HEX.BOLT        | VIS 6 PANS            | TORNILLO HEXAGONAL | M10X 65 DIN 931- 8-8-A4C                                     |     |
| 99      | 111 1335 | 4          | SECHSKANTSCHRAUBE  | HEX.BOLT        | VIS 6 PANS            | TORNILLO HEXAGONAL | M10X 55 DIN 931- 8-8-A4C                                     |     |
| 100     | 111 1124 | 6          | SECHSKANTSCHRAUBE  | HEX.BOLT        | VIS 6 PANS            | TORNILLO HEXAGONAL | M 8X 25 DIN 931-M 8-8 VZKC                                   |     |
| 102     | 231 6043 | 2          | NUTMUTTER          | GROOVED NUT     | ECROU RAINURE         | TUERCA RANURADA    |  | 01  |
| 105     | 110 784b | 2          | SICHERUNGSRING     | CIRCLIP         | CIRCLIP               | CIRCLIP            | 6X2,5 DIN 472  |     |
| 108     | 232 1981 | 2          | BUCHSE             | BUSH            | DOUILLE               | CASQUILLO          | 8001.AB ACHSEN-NO 1253<br>POS-37                             |     |
| 110     | 232 5551 | 1          | DIFFER.GEHAUESE    | DIFF.CASE       | CARTER DU DIFFER      | CAJA DIFERENCIAL   |  |     |
| 111     | 232 5740 | 2          | GELENKWELLE        | JOINT SHAFT     | ARBRE A CARDAN        | EJE ARTICULADO     |  |     |
| 113     | 232 5741 | 2          | NABE               | HUB             | MOYEU                 | CUBO               | 8001.AB ACHSEN-NO.1711-6808<br>8001.AB ACHSEN-NO.6809 POS195 |     |
| 114     | 232 5742 | 2          | FLANSCH            | FLANGE          | BRIDE/COLLET          | BRIDA              | 8025.BIS ACHSEN-NO 6808<br>8001.AB ACHSEN-NO 6809 POS193     |     |
| 115     | 232 5743 | 1          | NABENTRAEGER       | HUB CARRIER     | SUPPORT DE MOYEU      | PORTA-CUBO         | 8195.LINKS   |     |
| 116     | 232 5744 | 1          | NABENTRAEGER       | HUB CARRIER     | SUPPORT DE MOYEU      | PORTA-CUBO         | 8262.RECHTS  |     |
| 117     | 232 5745 | 2          | RING               | RING            | BAGUE/ANNEAU          | ANILLO             | 8361.INNEN   | 01  |
| 118     | 232 5746 | 2          | RING               | RING            | BAGUE/ANNEAU          | ANILLO             | 8013.AUSSEN  | 01  |
| 119     | 233 4257 | 1          | SCHEIBE            | DISC/PANE/PLATE | RONDELLE/DISQUE       | DISCO              |  |     |
| 121     | 237 2174 | 2          | TRAEGER            | SUPPORT/CARRIER | SUPPORT/POUTRE        | VIGA/SOPORTE       | 8001.AB ACHSEN-NO 4074                                       |     |
| 122     | 237 2175 | 1          | KUGELGELENK        | BALL JOINT      | JOINT A ROTULE        | ARTICULAC-ESFERIC  | 8041.BEI ERSTMALIGEN ERSATZ<br>POS.173-157-159+174MITLIEFERN |     |
| 123     | 237 3524 | 1          | KUGELGELENK        | BALL JOINT      | JOINT A ROTULE        | ARTICULAC-ESFERIC  | 8041.BEI ERSTMALIGEN ERSATZ<br>POS.173-157-159+174MITLIEFERN |     |
| 124     | 110 6354 | 2          | SICHERUNGSBLECH    | LOCKING PLATE   | TOLE DE SECURITE      | CHAPA SEGURIDAD    | 13 DIN 93-ST VZKC<br>8027.BIS FAHRGESTELL-NO                 |     |
| 132     | 110 4151 | 2          | VERSCHLUSSSCHRAUBE | SCREW PLUG      | BOUCHON FILETE        | TAPON ROSCADO      | M20X1,5 DIN 906- 5-8   |     |
| 135     | 231 1121 | IP         | ACHSBRUECKE        | AXLE BRACKET    | PONT ESSIEU           | PUNTE EJE          | 8367.ZU POS.3  |     |
| 145     | 233 0371 | 1          | SCHEIBE            | DISC/PANE/PLATE | RONDELLE/DISQUE       | DISCO              | D 1MM  |     |
| 151     | 110 1323 | 12         | KUGELBUNDMUTTER    | SHOULDER NUT    | ECROU COLLET SPHER    | TUERC-COLLAR-ESFER | A18 DIN74361-86 VZKC   |     |
| 152     | 233 0369 | SZ         | SCHEIBE            | DISC/PANE/PLATE | RONDELLE/DISQUE       | DISCO              |  |     |
| 153     | 231 6787 | 1          | LAGERGEHAUESE      | BEARING HOUSING | BOITIER DE PALIER     | CAJA SOPORTE       |  |     |
| 154     | 233 9345 | 8          | SCHMIERNIPPEL      | LUBE FITTING    | RACCOR GRASSEUR       | NIPLE LUBRICACION  |  | 01  |
| 155     | 116 822b | 1          | SCHMIERNIPPEL      | LUBE FITTING    | RACCOR GRASSEUR       | NIPLE LUBRICACION  | SA10H 3360   | 01  |
| 156     | 231 5688 | 2          | BUCHSE             | BUSH            | DOUILLE               | CASQUILLO          |  |     |
| 157     | 237 8933 | 1          | LENKHEBEL          | STEERING ARM    | LEVIER DE DIRECTIO    | PALANCA DIRECCION  |  |     |
| 158     | 237 8935 | 1          | LENKSPURHEBEL      | STEERING ARM    | LEV ATTAQUE FUSEE     | PALANCA BIELA ACOF |  |     |
| 159     | 237 8936 | 1          | SPURSTANGE         | TRACK ROD       | BARRE ACCOUPLEMENT    | BIELA ANCHO RODAD. |  |     |
| 160     | 231 1120 | IP         | ACHSBRUECKE        | AXLE BRACKET    | PONT ESSIEU           | PUNTE EJE          | 8367.ZU POS.2  |     |
| 161     | 232 5737 | 4          | LAGERBUCHSE        | BEARING BUSH    | BAGUE DE PALIER       | CASQU-COJINETE     |  |     |
| 162     | 231 1172 | 1          | DICHTUNG           | GASKET          | GARNITURE/JOINT       | JUNTA              |  |     |
| 163     | 111 2245 | 4          | SECHSKANTSCHRAUBE  | HEX.BOLT        | VIS 6 PANS            | TORNILLO HEXAGONAL | M 8X 10 DIN 933- 8-8-A4C                                     |     |
| 164     | 231 1202 | 1          | ENTLUEFTUNGSVENTIL | BREATHER VALVE  | SOUP DEGAGEMENT D AIR | VALV-PRGA-AIRE     |  |     |
| 165     | 231 1165 | 2          | VERSCHLUSSSCHRAUBE | SCREW PLUG      | BOUCHON FILETE        | TAPON ROSCADO      | 8025.BIS ACHSEN-NO.5529<br>8002.AB ACHSEN-NO.5530 POS132     |     |
| 166     | 231 1162 | 10         | STIFTSCHRAUBE      | STUD            | GOUJON                | ESPARRAGO          |  |     |
| 167     | 111 3477 | 6          | STIFTSCHRAUBE      | STUD            | GOUJON                | ESPARRAGO          | M10 X 35 DIN 939- 8-8-PHOSPH                                 |     |

| Bil. Nr. | Teil-Nr. | Stück-Zahl | Deutsch           | English         | Français          | Español            | Nummer/Bemerkung             | ETK |
|----------|----------|------------|-------------------|-----------------|-------------------|--------------------|------------------------------|-----|
| 170      | 231 1182 | 8          | STIFTSCHRAUBE     | STUD            | GOIJON            | ESPARRAGO          |                              |     |
| 171      | 237 8943 | 1          | TRIEBACHSE        | DRIVING AXLE    | ESSIEU MOTEUR     | EJE MOTRIZ         |                              |     |
| 172      | 233 0372 | 1          | SCHEIBE           | DISC/PANE/PLATE | RONDELLE/DISQUE   | DISCO              | D 2 mm.                      |     |
| 173      | 237 8946 | 2          | KUGELGELENK       | BALL JOINT      | JOINT A ROTULE    | ARTICULAC-ESFERIC  |                              |     |
| 174      | 237 8938 | 2          | SECHSKANTMUTTER   | HEX-NUT         | ECROU 6 PANS      | TUERCA HEXAGONAL   |                              |     |
| 176      | 237 6770 | 1          | LAGERGEHAEUSE     | BEARING HOUSING | BOITIER DE PALIER | CAJA SOPORTE       |                              |     |
| 177      | 238 1587 | 2          | BOLZEN            | PIN/BOLT/STUD   | BOULON/AXE        | BULON              |                              |     |
| 180      | 231 1186 | 10         | SCHRAUBE          | SCREW/BOLT      | VIS/BOULON        | TORNILLO           |                              |     |
| 181      | 111 1060 | 2          | SECHSKANTSCHRAUBE | HEX-BOLT        | VIS 6 PANS        | TORNILLO HEXAGONAL | M 6x 28 DIN 913- 8-8         |     |
| 182      | 231 1187 | IP         | SCHRAUBE          | SCREW/BOLT      | VIS/BOULON        | TORNILLO           |                              |     |
| 183      | 231 1188 | IP         | KRONENMUTTER      | CASTLE NUT      | ECROU CRENELE     | TUERCA CORONA      |                              |     |
| 184      | 110 6434 | 10         | SPLINT            | SPLIT PIN       | GOUPILLE FENDUE   | PASADOR ALETAS     | 3 X 25DIN 94                 |     |
| 193      | 238 2022 | 2          | FLANSCH           | FLANGE          | BRIDE/COLLET      | BRIDA              | B247-0HNE POS-8b             |     |
| 195      | 238 2025 | 2          | NABE              | HUB             | MOYEU             | CUBO               | B247-0HNE POS-8b             |     |
| 950      | 232 2600 | 1          | TRAEGER           | SUPPORT/CARRIER | SUPPORT/POUTRE    | VIGA/SOPORTE       | B002-AB AXSEN NO-1711 POS115 |     |
| 951      | 232 2599 | 1          | TRAEGER           | SUPPORT/CARRIER | SUPPORT/POUTRE    | VIGA/SOPORTE       | B002-AB AXSEN NO-1711 POS116 |     |

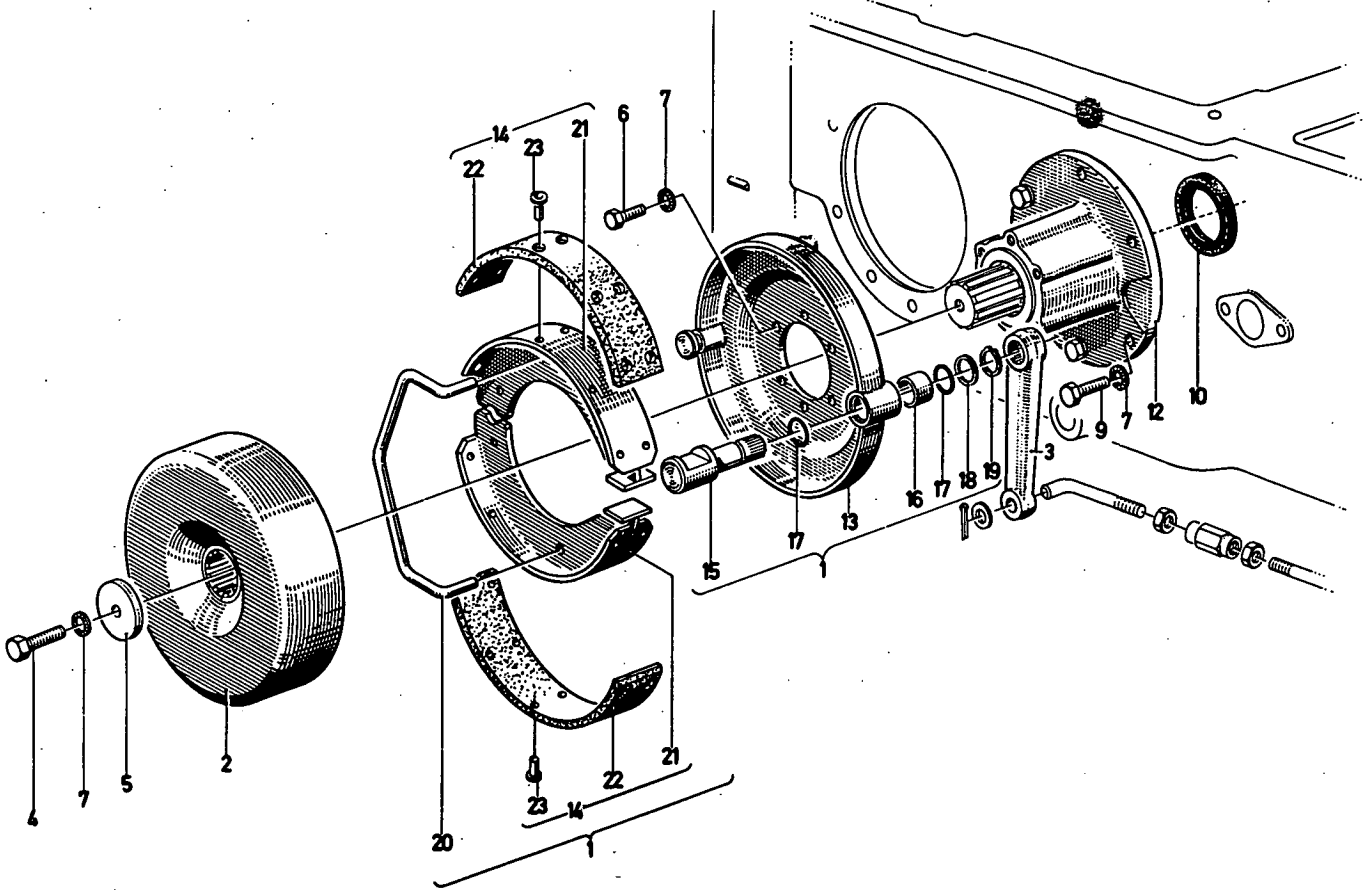

| Bld Nr. | Teil-Nr. | Stück-Zahl | Deutsch           | English         | Français           | Español            | Nummer/Bemerkung         | ETK |
|---------|----------|------------|-------------------|-----------------|--------------------|--------------------|--------------------------|-----|
| 1       | 231 3703 | 1          | BREMSE            | BRAKE           | FREIN              | FRENO              |                          |     |
| 2       | 231 3704 | 1          | BREINSTROMMEL     | BRAKE DRUM      | TAMBOUR DE FREIN   | TAMBOR FRENO       |                          |     |
| 3       | 339 2100 | 1          | HEBEL             | LEVER/ARM       | LEVIER             | PALANCA            | 1424-29-03-04            |     |
| 4       | 111 2311 | 1          | SECHSKANTSCHRAUBE | HEX-BOLT        | VIS 6 PANS         | TORNILLO HEXAGONAL | M 8X 18 DIN 933- 8-8-A9C |     |
| 5       | 339 2102 | 1          | SCHIEBE           | DISC/PANE/PLATE | RONDELLE/DISQUE    | DISCO              | 1424-29-03-05            |     |
| 6       | 231 3855 | 6          | PASSSCHRAUBE      | FITTED BOLT     | VIS D AJUSTAGE     | TORN-VAST-CALIBRAD |                          |     |
| 7       | 116 9689 | 7          | SICHERUNGSSCHIEBE | LOCKING WASHER  | RONDELLE SECURITE  | ARANDELA SEGURIDAD | 8 H 2203                 |     |
| 9       | 111 2326 | 6          | SECHSKANTSCHRAUBE | HEX-BOLT        | VIS 6 PANS         | TORNILLO HEXAGONAL | M 8X 22 DIN 933- 8-8-A9C |     |
| 10      | 116 5272 | 1          | DICHTRING         | WASHER          | BAGUE D ETANCHEITE | ANILLO DE JUNTA    | A 45X 65 X10 H 645       | 01  |
| 12      | 231 3858 | 1          | BREMSTRAEGER      | BRAKE BACKPLATE | PORTE-FREIN        | PORTA-FRENO        |                          |     |
| 13      | 231 6441 | 1          | BREMSTRAEGER      | BRAKE BACKPLATE | PORTE-FREIN        | PORTA-FRENO        |                          |     |
| 14      | 230 6973 | 2          | BREMSBACKE        | BRAKE SHOE      | NACHOIRE DE FREIN  | MORDAZA FRENO      |                          |     |
| 15      | 230 7083 | 1          | BREMSVELLE        | BRAKE SHAFT     | ARBRE DE FREIN     | EJE FRENO          |                          |     |
| 16      | 231 6469 | 1          | BUCHSE            | BUSH            | BOUILLE            | CASQUILLO          |                          |     |
| 17      | 230 7085 | 2          | O-RING            | O-SEAL          | BAGUE TORIQUE      | ANILLO O           |                          | 01  |
| 18      | 230 7086 | 1          | SCHIEBE           | DISC/PANE/PLATE | RONDELLE/DISQUE    | DISCO              |                          |     |
| 19      | 110 7730 | 1          | SICHERUNGSRING    | CIRCLIP         | CIRCLIP            | CIRCLIP            | 20X1,2 DIN 471           |     |
| 20      | 230 7084 | 1          | FEDER             | SPRING          | RESSORT            | RESORTE/BALLESTA   |                          |     |
| 21      | 230 7087 | IP         | BREMSBACKE        | BRAKE SHOE      | NACHOIRE DE FREIN  | MORDAZA FRENO      | 8285-SIEHE POS.14        |     |
| 22      | 230 7088 | 1          | BREMSBELAG        | BRAKE LINING    | GARNITURE DE FREIN | FORRO FRENO        |                          | 01  |
| 23      | 111 8460 | 10         | NIET              | RIVET           | RIVET              | RENACHE            | 8 3X 8DIN 7338-MS        |     |

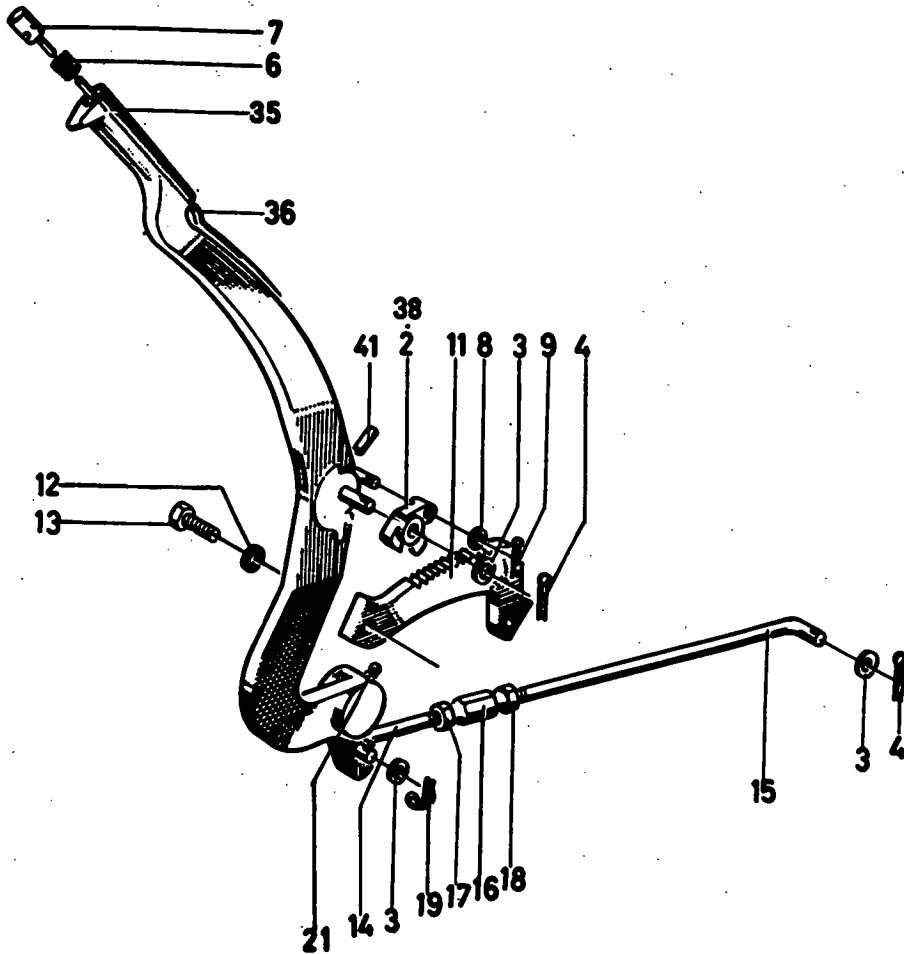

| Bld Nr. | Teile-Nr. | Stück-Zahl | Deutsch            | English          | Français          | Español            | Nummer/Bemerkung                         | ETK |
|---------|-----------|------------|--------------------|------------------|-------------------|--------------------|--|-----|
| 2       | 338 8925  | 1          | SPERRKLINKE        | PAWL/CATCH       | CLIQUET D ARRET   | UNA TRINQUETE      | 1136-29-03-02<br>8355, WAHLWEISE POS. 38 |     |
| 3       | 110 7553  | 1          | SCHEIBE            | DISC/PANE/PLATE  | RONDELLE/DISQUE   | DISCO              | 13,50DIN 933                             |     |
| 4       | 110 6446  | 1          | SPLINT             | SPLIT PIN        | GOUPILLE FENDUE   | PASADOR ALETAS     | 4 X 20DIN 94                             |     |
| 6       | 338 8928  | 1          | SCHRAUBENFEDER     | HELICAL SPRING   | RESSORT A BOUDIN  | RESORTE HELICOIDAL | 1136-29-03-06                            | 01  |
| 7       | 338 8929  | 1          | DRUCKKNOPF         | PUSHBUTTON       | BOUTON-POUSSOIR   | PULSADOR           | 1136-29-03-07                            |     |
| 8       | 110 7098  | 1          | SCHEIBE            | DISC/PANE/PLATE  | RONDELLE/DISQUE   | DISCO              | 8,40DIN 125                              |     |
| 9       | 110 6496  | 1          | SPLINT             | SPLIT PIN        | GOUPILLE FENDUE   | PASADOR ALETAS     | 6 X100DIN 94                             |     |
| 11      | 338 8930  | 1          | RASTE              | DETENT/NOTCH     | CRAN              | TRINQUETE          | 1136-29-03-11                            |     |
| 12      | 116 9694  | 2          | SICHERUNGSSCHEIBE  | LOCKING WASHER   | RONDELLE SECURITE | ARANDELA SEGURIDAD | 10 H 2203                                |     |
| 13      | 111 2397  | 2          | SECHSKANTSCHRAUBE  | HEX-BOLT         | VIS 6 PANS        | TORNILLO HEXAGONAL | M10X 18 DIN 933- 8-8-A4C                 |     |
| 14      | 338 7742  | 1          | ZUGSTANGE          | PULLROD          | TIRANT            | BARRA TRACCION     | 1125-29-01-08                            |     |
| 15      | 338 9292  | 1          | ZUGSTANGE          | PULLROD          | TIRANT            | BARRA TRACCION     | 1145-29-01-15                            |     |
| 16      | 111 5362  | 1          | SPANNSCHLOSSMUTTER | TURNBUCKLE       | ECROU TENDEUR     | TUERCA CIERRE TENS | M12DIN 1479                              |     |
| 17      | 111 2858  | 1          | SECHSKANTMUTTER    | HEX-NUT          | ECROU 6 PANS      | TUERCA HEXAGONAL   | M12 DIN 934-M 8 A4C                      |     |
| 18      | 111 2863  | 1          | SECHSKANTMUTTER    | HEX-NUT          | ECROU 6 PANS      | TUERCA HEXAGONAL   | M12 LINKS DIN 934-M 8 A4C                |     |
| 19      | 338 7776  | 1          | SICHERUNGSTIFT     | LOCKING PIN      | GOUPILLE D ARRET  | PERNO AFIANZADOR   | 1125-30-01-16                            | 01  |
| 21      | 116 8225  | 1          | KEGELSCHIERNIPPEL  | LUBE FITTING     | GRAISSEUR CONIQUE | ENGRASADOR CONICO  | SA 84 3360                               |     |
| 35      | 232 5887  | 1          | HANDBREMSHEBEL     | HAND BRAKE LEVER | LEVIER DE FR MAIN | PLANCA FRENO MANO  |  |     |
| 36      | 232 5884  | 1          | HEBEL              | LEVER/ARM        | LEVIER            | PLANCA             |  |     |
| 38      | 232 5879  | 1          | SPERRIEGEL         | LOCKING BAR      | VERROU DE SURETE  | CERROJO BLOQUEO    |  |     |
| 41      | 111 5423  | 1          | SPANNHUELSE        | DOWEL SLEEVE     | DOUILLE SERRAGE   | CASQUILLO FIADOR   | 4 X 24DIN 1481                           |     |

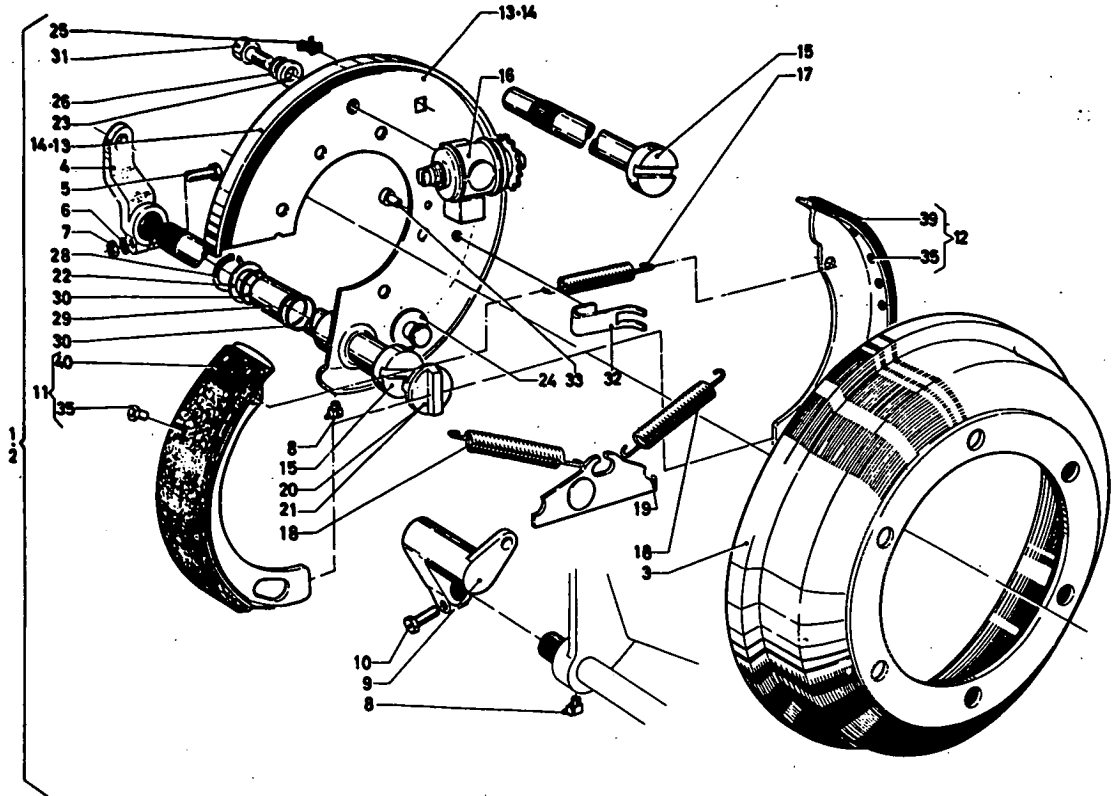

| Bld. Nr. | Teil-Nr. | Stück-Zahl | Deutsch            | English           | Français          | Español            | 1435-30 500 4209<br>Nummer/Bemerkung                   | ETK |
|----------|----------|------------|--------------------|-------------------|-------------------|--------------------|--|-----|
| 1        | 233 5378 | 1          | BREMSE             | BRAKE             | FREIN             | FRENO              | 8267•RECHTS  |     |
| 2        | 233 5377 | 1          | BREMSE             | BRAKE             | FREIN             | FRENO              | 8195•LINKS   |     |
| 3        | 337 2556 | 2          | BREMSTROMMEL       | BRAKE DRUM        | TAMBOUR DE FREIN  | TAMBOR FRENO       | 1445-30-01.12  |     |
| 4        | 233 2781 | 2          | HEBEL              | LEVER/ARM         | LEVIER            | PALANCA            |  |     |
| 5        | 111 1308 | 2          | SECHSKANTSCHRAUBE  | HEX-BOLT          | VIS 6 PANS        | TORNILLO HEXAGONAL | M10X 50 DIN 931-M 8-8 A4C                              |     |
| 6        | 110 2800 | 2          | FEDERRING          | SPRING LOCKWASHER | RONDELLE GROMER   | ARANDELA ELASTICA  | A 10 DIN 128 A4C                                       |     |
| 7        | 110 2657 | 2          | SECHSKANTMUTTER    | HEX-NUT           | ECROU 6 PANS      | TUERCA HEXAGONAL   | M10 DIN 934-M 8 A4C                                    |     |
| 8        | 116 8227 | 2          | SCHMIERNIPPEL      | LUBE FITTING      | RACCORD GRAISSEUR | NIPLE LUBRICACION  | SC 8H 3360   | 01  |
| 9        | 233 2783 | 1          | BREMSHEBEL         | BRAKE LEVER       | LEVIER DE FREIN   | PALANCA FRENO      | 8009•ALLRADAUSFUEHRUNG                                 |     |
| 10       | 110 3335 | 1          | SECHSKANTSCHRAUBE  | HEX-BOLT          | VIS 6 PANS        | TORNILLO HEXAGONAL | M10X1 X 35 DIN 961-M 8-8 A4C<br>8009•ALLRADAUSFUEHRUNG |     |
| 11       | 233 8137 | 2          | BREMSBACKE         | BRAKE SHOE        | HACHOIRE DE FREIN | MORDAZA FRENO      | 8190•LANG  |     |
| 12       | 233 8140 | 2          | BREMSBACKE         | BRAKE SHOE        | HACHOIRE DE FREIN | MORDAZA FRENO      | 8182•KURZ  |     |
| 13       | 233 8141 | 1          | BREMSDECKPLATTE    | BRAKE COVER PLATE | PLAQUE COUV FREIN | PLACA CUBRE-FRENO  | 8195•LINKS   |     |
| 14       | 233 8142 | 1          | BREMSDECKPLATTE    | BRAKE COVER PLATE | PLAQUE COUV FREIN | PLACA CUBRE-FRENO  | 8267•RECHTS  |     |
| 15       | 233 8143 | 2          | BREMSWELLE         | BRAKE SHAFT       | ARBRE DE FREIN    | EJE FRENO          |  |     |
| 16       | 337 2138 | 2          | NACHSTELLVORRICHTG | ADJUSTING DEVICE  | RATTRAPAGE DE JEU | DISP-REAJUSTE      | 1424-30-04.10  |     |
| 17       | 337 2117 | 2          | ZUGFEDER           | DRAW SPRING       | RESSORT TRACTION  | RESORTE TRACCION   | 1424-30-02.07  |     |
| 18       | 337 2118 | 4          | ZUGFEDER           | DRAW SPRING       | RESSORT TRACTION  | RESORTE TRACCION   | 1424-30-02.06  |     |
| 19       | 230 0244 | 2          | LASCHE             | CONNECTING PLATE  | ECLISSE           | ECLISA             |  |     |
| 20       | 337 2123 | 1          | NOCKEN             | CAM               | CAME              | LEVA               | 1424-30-02.11<br>8195•LINKS                            |     |
| 21       | 337 2124 | 1          | NOCKEN             | CAM               | CAME              | LEVA               | 1424-30-02.12<br>8267•RECHTS                           |     |

| Bld<br>Nr. | Teil-Nr. | Stück-<br>Zahl | Deutsch           | English         | Français           | Español            | Nummer/Bemerkung             | ETK |
|------------|----------|----------------|-------------------|-----------------|--------------------|--------------------|------------------------------|-----|
| 22         | 339 2125 | 2              | SCHEIBE           | DISC/PANE/PLATE | RONDELLE/DISQUE    | DISCO              | 1424-30-02.13                |     |
| 23         | 339 2126 | 2              | SCHEIBE           | DISC/PANE/PLATE | RONDELLE/DISQUE    | DISCO              | 1424-30-02.14                |     |
| 24         | 339 2127 | 4              | SCHEIBE           | DISC/PANE/PLATE | RONDELLE/DISQUE    | DISCO              | 1424-30-02.15                |     |
| 25         | 334 7653 | 2              | VERSCHLUSSSTOPFEN | NIPPLE          | BOUCHON            | TAPON OBTURADOR    | 335 12 123                   |     |
| 26         | 110 7289 | 1              | FEDERSCHEIBE      | SPRING WASHER   | RONDELLE ELASTIQUE | ARANDELA ELASTICA  | 012 DIN 137 VZKC             |     |
| 28         | 110 7739 | 2              | SICHERUNGSRING    | CIRCLIP         | CIRCLIP            | CIRCLIP            | 26X1.2 DIN 971               |     |
| 29         | 339 2383 | 2              | BUCHSE            | BUSH            | DOUILLE            | CASQUILLO          | 1425-30-21.25                |     |
| 30         | 339 2130 | 4              | O-RING            | O-SEAL          | BAGUE TORIQUE      | ANILLO O           | 1434-30-02.24                | 01  |
| 31         | 111 4285 | 2              | SECHSKANTSCHRAUBE | HEX-BOLT        | VIS 6 PANS         | TORNILLO HEXAGONAL | M2X1.5X 20 DIN 913-M 8.8 A4C |     |
| 32         | 339 2133 | 4              | BLATTFEDER        | LEAF SPRING     | RESSORT A LAMES    | BALLESTA           | 1424-30-03.04                |     |
| 33         | 111 8475 | 4              | NIET              | RIVET           | RIVET              | RENACHE            | 0 6X12DIN 7336-MS            |     |
| 35         | 113 3087 | 60             | NIET              | RIVET           | RIVET              | RENACHE            | 0 4X 8DIN 7336-MS            |     |
| 37         | 233 8144 | 2              | BREMSBELAG        | BRAKE LINING    | GARNITURE DE FREIN | FORRO FRENO        | 0182-KURZ                    | 01  |
| 40         | 233 8145 | 2              | BREMSBELAG        | BRAKE LINING    | GARNITURE DE FREIN | FORRO FRENO        | 0190-LANG                    | 01  |



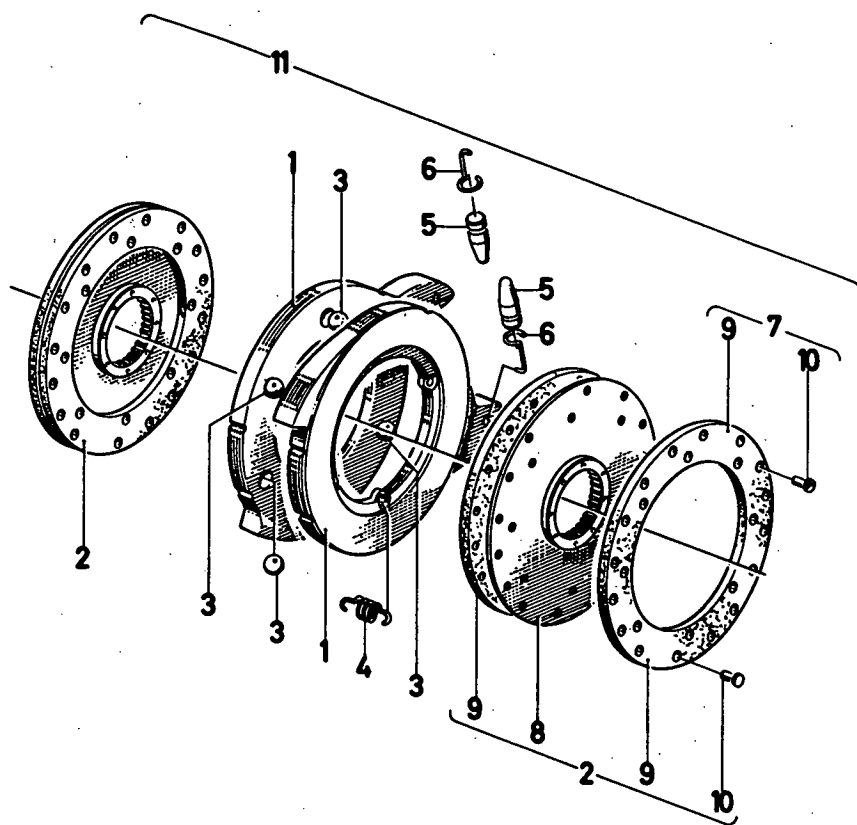

| Bild Nr. | Teile-Nr. | Stück-Zahl | Deutsch            | English         | Français           | Español           | 1446-30 502 0180   |     |
|----------|-----------|------------|--------------------|-----------------|--------------------|-------------------|--------------------|-----|
|          |           |            |                    |                 |                    |                   | Nummer/Bemerkung   | ETK |
| 1        | 238 5577  | 2          | BETAETIGUNGSSCHEIB | OPERATING PLATE | DISQUE OPERATION-  | DISCO OPERACION   |                    |     |
| 2        | 233 2776  | 2          | BELAGSCHEIBE       | LINING          | DISQUE-GARNITURE   | PLATO DE FORRO    |                    | 01  |
| 3        | 230 5008  | 6          | KUGEL              | BALL            | BILLE/BOULE        | BOLA              |                    | 01  |
| 4        | 230 5009  | 4          | ZUGFEDER           | DRAW SPRING     | RESSORT TRACTION   | RESORTE TRACCION  |                    | 01  |
| 5        | 230 5011  | 2          | STÖSSEL            | TAPPET/PLUNGER  | POUSSOIR           | TAQUE/EMPUJADOR   |                    | 01  |
| 6        | 230 5010  | 2          | FEDER              | SPRING          | RESSORT            | RESORTE/BALLESTA  |                    | 01  |
| 7        | 237 4363  | 1          | BELAG              | FACING/LINING   | GARNITURE          | FORRO             | B269-REPARATURSATZ | 01  |
| 8        | 233 3777  | IP         | BELAGSCHEIBE       | LINING          | DISQUE-GARNITURE   | PLATO DE FORRO    | B285-SIEME POS-2   |     |
| 9        | 233 3817  | IP         | BELAG              | FACING/LINING   | GARNITURE          | FORRO             | B285-SIEME POS-7   | 01  |
| 10       | 233 3818  | IP         | NIET               | RIVET           | RIVET              | RENACHE           | B285-SIEME POS-7   | 01  |
| 11       | 238 5576  | 1          | VOLLSCHEIBENBREMSE | FULL DISC BRAKE | FREIN DISQUE PLEIN | FRENO PLENO DISCO |                    |     |

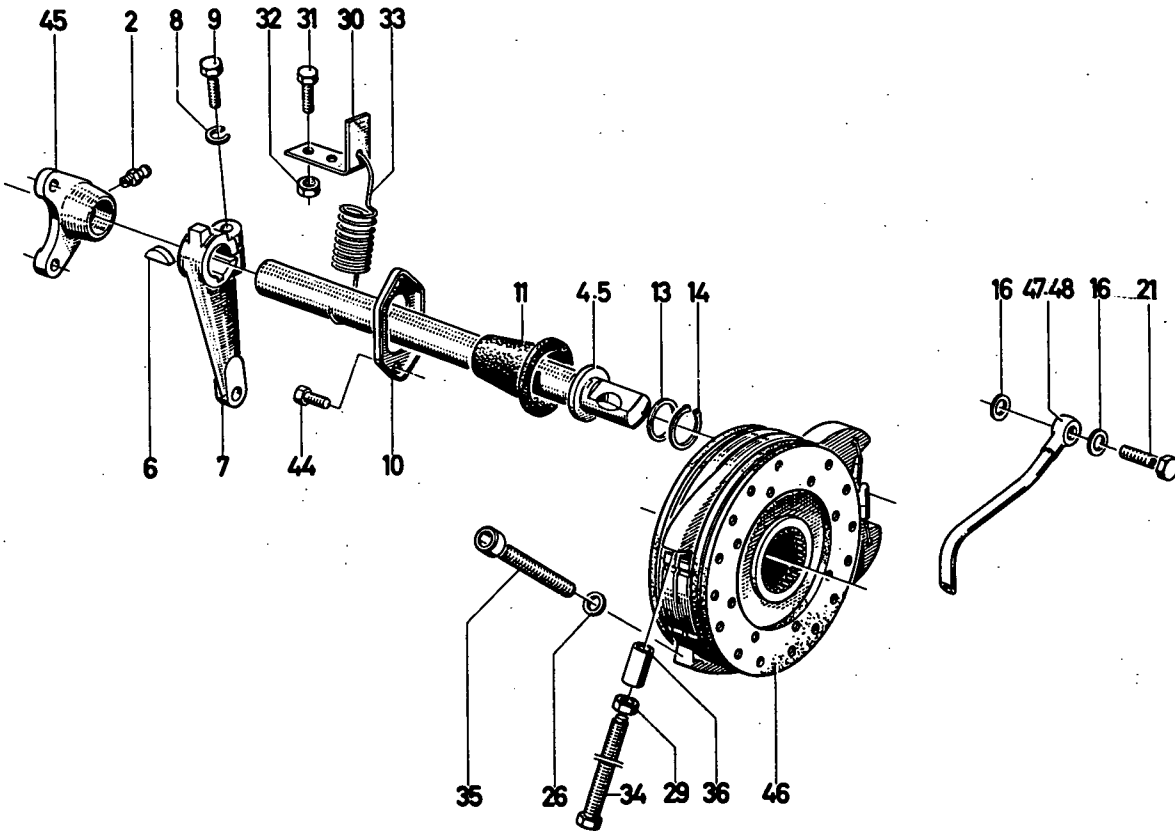

| Bild Nr. | Teil-Nr. | Stück-Zahl | Deutsch             | English           | Francés            | Español            | 1446-30 502 0209<br>Nummer/Bemerkung | EIK |
|----------|----------|------------|---------------------|-------------------|--------------------|--------------------|--------------------------------------|-----|
| 2        | 114 8225 | 2          | KEGELSCHMIERNIPPEL  | LUBE FITTING      | GRAISSEUR CONIQUE  | ENGRASADOR CONICO  | SA 8H 336D                           | 01  |
| 4        | 232 6087 | 1          | WELLE               | SHAFT             | ARBRE              | EJE/ARBOL          | B267-RECHTS                          |     |
| 5        | 232 6088 | 1          | WELLE               | SHAFT             | ARBRE              | EJE/ARBOL          | B195-LINKS                           |     |
| 6        | 110 1503 | 2          | SCHEIBENFEDER       | WOODRUFF KEY      | CLAVETTE WOODRUFF  | CHAVETA MEDIA LUNA | 10 X13 DIN 6888                      |     |
| 7        | 232 2665 | 2          | HEBEL               | LEVER/ARM         | LEVIER             | PALANCA            |                                      |     |
| 8        | 110 2800 | 2          | FEDERRING           | SPRING LOCKWASHER | RONDELLE GROMER    | ARANDELA ELASTICA  | A 10 DIN 128 VZKC                    |     |
| 9        | 111 2431 | 2          | SECHSKANTSCHRAUBE   | HEX-BOLT          | VIS 6 PANS         | TORNILLO HEXAGONAL | M10X35 DIN 933-M8-A4C                |     |
| 10       | 233 2674 | 2          | FLANSCH             | FLANGE            | BRIDE/COLLET       | BRIDA              |                                      |     |
| 11       | 232 6089 | 2          | MANSCHETTE          | SEAL/SLEEVE       | EMBOUTI/GARNITURE  | MANGUITO           |                                      | 01  |
| 13       | 233 2675 | 2          | SCHEIBE             | DISC/PANE/PLATE   | RONDELLE/DISQUE    | DISCO              |                                      |     |
| 14       | 110 7751 | 2          | SICHERUNGSRING      | CIRCLIP           | CIRCLIP            | CIRCLIP            | 36X1,75DIN 471                       |     |
| 16       | 111 8693 | 4          | DICHRING            | WASHER            | BAGUE D ETANCHEITE | ANILLO DE JUNTA    | A 14 X 20 DIN 7603-CU                |     |
| 21       | 111 9246 | 2          | HOHLSCHRAUBE        | BANJO BOLT        | VIS BANJO          | TORNILLO RACOR     | A 8 DIN 7623                         |     |
| 26       | 111 8707 | 4          | DICHRING            | WASHER            | BAGUE D ETANCHEITE | ANILLO DE JUNTA    | A 16 X 22 DIN 7603-CU                |     |
| 29       | 111 2886 | 2          | SECHSKANTMUTTER     | HEX-NUT           | ECROU 6 PANS       | TUERCA HEXAGONAL   | M 16 DIN 934 M 8 A4C 934-M 8         |     |
| 30       | 233 9837 | 2          | HALTER              | RETAINER          | SUPPORT/PORTEQUIL  | SOPORTE            |                                      |     |
| 31       | 111 2326 | 4          | SECHSKANTSCHRAUBE   | HEX-BOLT          | VIS 6 PANS         | TORNILLO HEXAGONAL | M 8X 22 DIN 933-M 8-8 A4C            |     |
| 32       | 111 2824 | 4          | SECHSKANTMUTTER     | HEX-NUT           | ECROU 6 PANS       | TUERCA HEXAGONAL   | M 8 DIN 934-M 8 A4C                  |     |
| 33       | 233 9816 | 2          | ZUGFEDER            | DRAW SPRING       | RESSORT TRACTION   | RESORTE TRACCION   |                                      | 01  |
| 34       | 110 9687 | 2          | SKT-ZAPFENSCHRAUBE  | SPIGOT SCREW      | VIS 6 P A TETON    | TORN-HEX-C-ESPIGA  | 8H 16X140 DIN 561-5-8 A4C            |     |
| 35       | 111 0855 | 2          | ZYLINDERSCHRAUBE    | CHEESE-HEAD SCREW | VIS TETE CYLINDR-  | TORN-CBZA-CILINDR- | M 16X70 DIN 912-10-9 A4C             |     |
| 36       | 237 0830 | 2          | ABSTANDRING         | SPACER RING       | BAGUE ECARTEMENT   | ARO DISTANCIARIO   |                                      |     |
| 44       | 110 3316 | 4          | SECHSKANTSCHRAUBE   | HEX-BOLT          | VIS 6 PANS         | TORNILLO HEXAGONAL | M 6X16 DIN 933-8-8-A4C               |     |
| 45       | 238 4799 | 2          | LAGERBOCK           | BRACKET           | CHEVALET SUPPORT   | CABALLETE SOPORTE  |                                      |     |
| 46       | 238 5576 | 2          | VOLLSCHLEIBENBREMSE | FULL DISC BRAKE   | FREIN DISQUE PLEIN | FRENO PLENO DISCO  |                                      |     |
| 47       | 238 8887 | 1          | ENTLUEFTUNGSRÖHR    | BREATHER PIPE     | TUBE DE DESAERAGE  | TUBO PRG-AIRE      | B267-RECHTS                          |     |
| 48       | 238 8889 | 1          | ENTLUEFTUNGSRÖHR    | BREATHER PIPE     | TUBE DE DESAERAGE  | TUBO PRG-AIRE      | B195-LINKS                           |     |

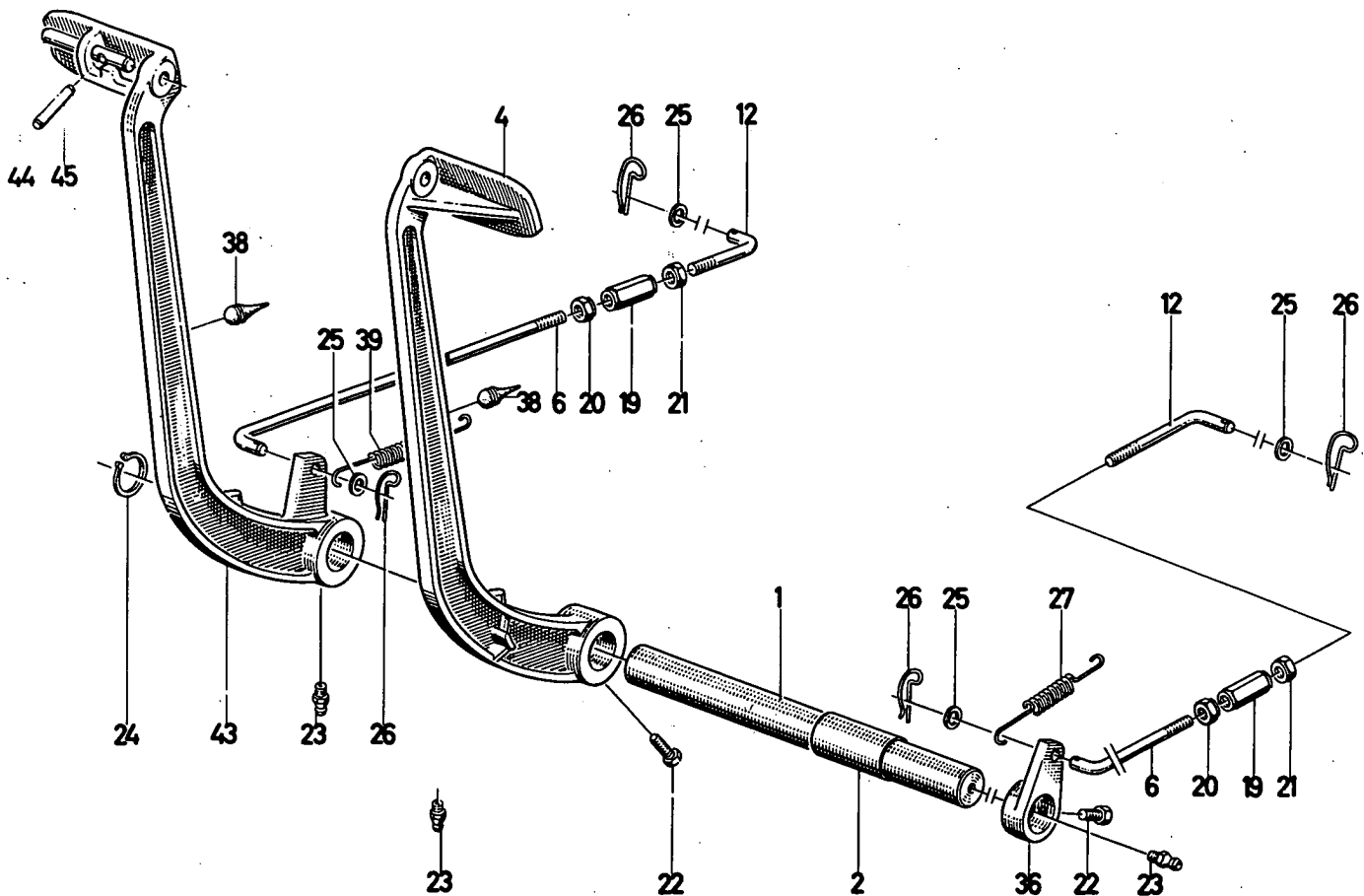

1001-30 500 5413

| Bild Nr. | Teil-Nr. | Stück-Zahl | Deutsch            | English         | Français           | Español            | Nummer/Bemerkung          | ETK |
|----------|----------|------------|--------------------|-----------------|--------------------|--------------------|---------------------------|-----|
| 1        | 233 9640 | 1          | BREMSWELLE         | BRAKE SHAFT     | ARBRE DE FREIN     | EJE FRENO          |                           |     |
| 2        | 233 9609 | 1          | BÜCHSE             | BUSH            | DOUILLE            | CASQUILLO          |                           |     |
| 4        | 233 1637 | 1          | BREMSPEDAL         | BRAKE PEDAL     | PEDALE DE FREIN    | PEDAL FRENO        | B195-LINKS                |     |
| 6        | 232 0876 | 2          | ZUGSTANGE          | PULLROD         | TIRANT             | BARRA TRACCION     |                           |     |
| 12       | 232 0877 | 2          | ZUGSTANGE          | PULLROD         | TIRANT             | BARRA TRACCION     |                           |     |
| 19       | 111 5363 | 2          | SPANNSCHLOSSMUTTER | TURNBUCKLE      | ECROU TENDEUR      | TUERCA CIERRE TENS | M12DIN 1479 VZKC          |     |
| 20       | 111 2863 | 2          | SECHSKANTMUTTER    | HEX-NUT         | ECROU 6 PANS       | TUERCA HEXAGONAL   | M12 LINKS DIN 934-M 8 A4C |     |
| 21       | 111 2858 | 2          | SECHSKANTMUTTER    | HEX-NUT         | ECROU 6 PANS       | TUERCA HEXAGONAL   | M12 DIN 934-M 8 A4C       |     |
| 22       | 338 6758 | 2          | STELLSCHRAUBE      | SET SCREW       | VIS DE REGLAGE     | TORNILLE GRADUAC.  | 1055-33-08-24             |     |
| 23       | 116 8225 | 3          | SCHNIEHNIPPEL      | LUBE FITTING    | RACCORD GRAISSEUR  | NIPLE LUBRICACION  | SA 8H 3360                |     |
| 24       | 110 7740 | 1          | SICHERUNGSRING     | CIRCLIP         | CIRCLIP            | CIRCLIP            | 28X1,5 DIN 473            |     |
| 25       | 110 7559 | 4          | SCHWEIBE           | DISC/PANE/PLATE | RONDELLE/DISQUE    | DISCO              | 13,5DIN 433-ST-A4C        |     |
| 26       | 338 7776 | 4          | SICHERUNGSSTIFT    | LOCKING PIN     | GOUPILLE D ARRET   | PERNO AFIANZADOR   | 1125-30-01-16             | 01  |
| 27       | 232 0842 | 1          | RUECKHOLFEDER      | RETURN SPRING   | RESSORT DE RAPPEL  | RESORTE ANTAGONIST |                           | 01  |
| 36       | 232 5556 | 1          | HEBEL              | LEVER/ARM       | LEVIER             | PALANCA            |                           |     |
| 38       | 232 1015 | 2          | GUMMIPUFFER        | RUBBER PAD      | TAMPON CAOUTCHOUC  | TOPE CAUCHO        |                           | 01  |
| 39       | 232 5877 | 1          | ZUGFEDER           | DRAW SPRING     | RESSORT TRACCION   | RESORTE TRACCION   |                           | 01  |
| 43       | 233 2648 | 1          | BREMSPEDAL         | BRAKE PEDAL     | PEDALE DE FREIN    | PEDAL FRENO        | B267-RECHTS               |     |
| 44       | 233 2649 | 1          | BOLZEN             | PIN/BOLT/STUD   | BOULON/AXE         | BULON              |                           |     |
| 45       | 110 4845 | 1          | ZYLINDERKERBSTIFT  | NOTCHED PIN     | GOUPILLE CYL-CRANT | PERNO CIL-RANURADO | 8 X 80DIN 1470            |     |

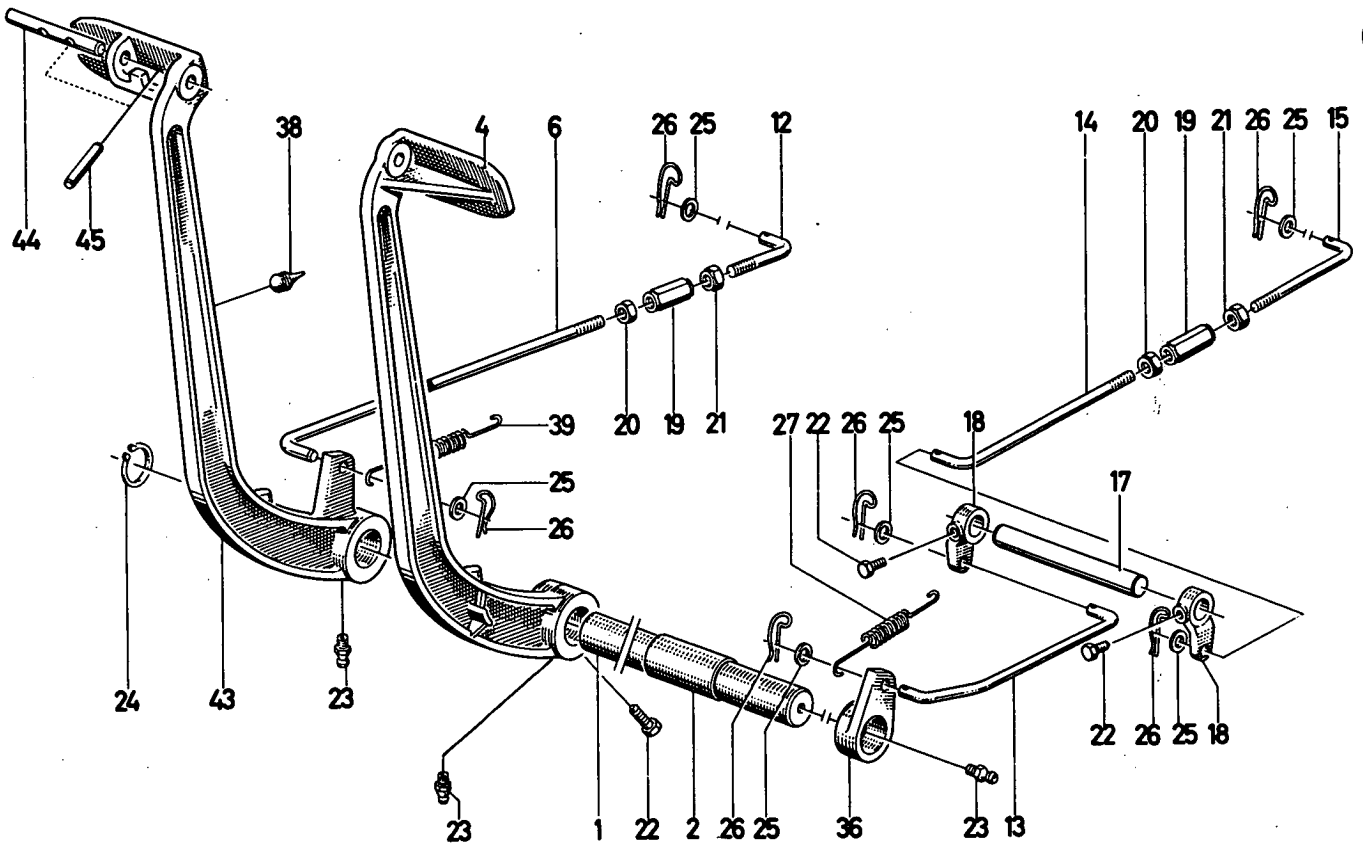

1001-30 500 5414

| Bld. Nr. | Teile-Nr. | Stück-Zahl | Deutsch            | English         | Français           | Español            | Nummer/Bemerkung                               | ETK |
|----------|-----------|------------|--------------------|-----------------|--------------------|--------------------|--|-----|
| 1        | 231 7640  | 1          | BREMSWELLE         | BRAKE SHAFT     | ARBRE DE FREIN     | EJE FRENO          |  |     |
| 2        | 231 7689  | 1          | BUCHSE             | BUSH            | DOUILLE            | CASQUILLO          |  |     |
| 4        | 231 1637  | 1          | BREMSPEDAL         | BRAKE PEDAL     | PEDALE DE FREIN    | PEDAL FRENO        | B195-LINKS                                     |     |
| 6        | 232 0876  | 1          | ZUGSTANGE          | PULLROD         | TIRANT             | BARRA TRACCION     |  |     |
| 12       | 232 0877  | 1          | ZUGSTANGE          | PULLROD         | TIRANT             | BARRA TRACCION     |  |     |
| 13       | 232 0826  | 1          | ZUGSTANGE          | PULLROD         | TIRANT             | BARRA TRACCION     |  |     |
| 14       | 230 6267  | 1          | ZUGSTANGE          | PULLROD         | TIRANT             | BARRA TRACCION     |  |     |
| 15       | 230 6266  | 1          | ZUGSTANGE          | PULLROD         | TIRANT             | BARRA TRACCION     |  |     |
| 17       | 230 6264  | 1          | WELLE              | SHAFT           | ARBRE              | EJE/ARBOL          |  |     |
| 18       | 230 6262  | 2          | HEBEL              | LEVER/ARM       | LEVIER             | PALANCA            |  |     |
| 19       | 111 5363  | 2          | SPANNSCHLOSSMUTTER | TURNBUCKLE      | ECROU TENDEUR      | TUERCA CIERRE TENS | M12DIN 1479 VZKC                               |     |
| 20       | 111 2863  | 2          | SECHSKANTMUTTER    | HEX-NUT         | ECROU 6 PANS       | TUERCA HEXAGONAL   | M12 LINKS DIN 934-M 8 A4C<br>B196-LINKSGEWINDE |     |
| 21       | 111 2858  | 2          | SECHSKANTMUTTER    | HEX-NUT         | ECROU 6 PANS       | TUERCA HEXAGONAL   | M12 DIN 934-M 8 A4C                            |     |
| 22       | 338 6958  | 4          | STELLSCHRAUBE      | SET SCREW       | VIS DE REGLAGE     | TORNILLO GRADUAC.  | 1055-33-08-29                                  |     |
| 23       | 116 8225  | 3          | SCHMIERNIPPEL      | LUBE FITTING    | RACCORD GRAISSEUR  | NIPLE LUBRICATION  | SA 8H 3360                                     | 01  |
| 24       | 110 7740  | 1          | SICHERUNGSRING     | CIRCLIP         | CIRCLIP            | CIRCLIP            | 26X1,5 DIN 471                                 |     |
| 25       | 110 7554  | 6          | SCHIEBE            | DISC/PANE/PLATE | RONDELLE/DISQUE    | DISCO              | 13-50DIN 433-ST-A4C                            |     |
| 26       | 338 7776  | 6          | SICHERUNGSSTIFT    | LOCKING PIN     | GOUPILLE D ARRET   | PERNO AFIANZADOR   |  | 01  |
| 27       | 232 0892  | 1          | RUECKHOLFEDER      | RETURN SPRING   | RESSORT DE RAPPEL  | RESORTE ANTAGONIST |  | 01  |
| 36       | 232 5576  | 1          | HEBEL              | LEVER/ARM       | LEVIER             | PALANCA            |  |     |
| 38       | 232 1015  | 2          | GUMMIPUFFER        | RUBBER PAD      | TAMPON CAOUTCHOUC  | TOPE CAUCHO        |  | 01  |
| 39       | 232 5877  | 1          | ZUGFEDER           | DRAW SPRING     | RESSORT TRACCION   | RESORTE TRACCION   |  | 01  |
| 43       | 233 2648  | 1          | BREMSPEDAL         | BRAKE PEDAL     | PEDALE DE FREIN    | PEDAL FRENO        | B267-RECHTS                                    |     |
| 44       | 233 2644  | 1          | BOLZEN             | PIN/BOLT/STUD   | BOULON/AXE         | BULON              |  |     |
| 45       | 110 4895  | 1          | ZYLINDERKERBSTIFT  | NOTCHED PIN     | GOUPILLE CYL-CRANT | PERNO CIL-RANURADO | 8 X 80DIN 1470                                 |     |

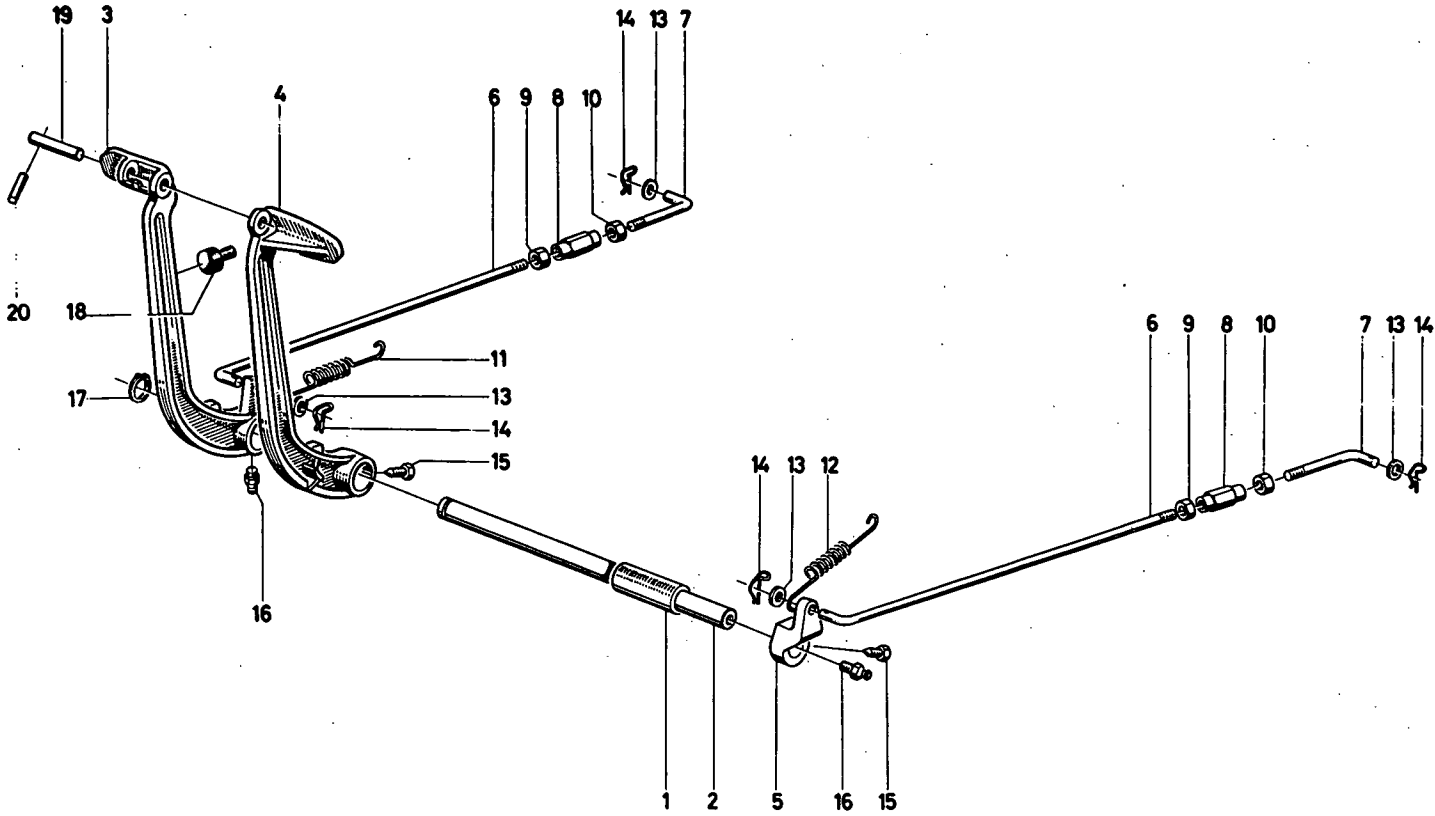

| Bild Nr. | Teile-Nr. | Stück-Zahl | Deutsch            | English         | Français           | Español            | Nummer/Bemerkung                               | ETK |
|----------|-----------|------------|--------------------|-----------------|--------------------|--------------------|--|-----|
| 1        | 233 9689  | 1          | BUCHSE             | BUSH            | DOUILLE            | CASQUILLO          |  |     |
| 2        | 233 9690  | 1          | BREMSWELLE         | BRAKE SHAFT     | ARBRE DE FREIN     | EJE FRENO          |  |     |
| 3        | 233 2477  | 1          | BREMSPEDAL         | BRAKE PEDAL     | PEDALE DE FREIN    | PEDAL FRENO        | 8267-RECHTS                                    |     |
| 4        | 233 1637  | 1          | BREMSPEDAL         | BRAKE PEDAL     | PEDALE DE FREIN    | PEDAL FRENO        | 8195-LINKS                                     |     |
| 5        | 232 9547  | 1          | HEBEL              | LEVER/ARM       | LEVIER             | PALANCA            |  |     |
| 6        | 233 2754  | 2          | ZUGSTANGE          | PULLROD         | TIRANT             | BARRA TRACCION     |  |     |
| 7        | 233 2755  | 2          | ZUGSTANGE          | PULLROD         | TIRANT             | BARRA TRACCION     |  |     |
| 8        | 111 5350  | 2          | SPANNSCHLOSSMUTTER | TURNBUCKLE      | ECROU TENDEUR      | TUERCA CIERRE TENS | AM12DIN 1478                                   |     |
| 9        | 111 2863  | 2          | SECHSKANTMUTTER    | HEX-NUT         | ECROU 6 PANS       | TUERCA HEXAGONAL   | M12 LINKS DIN 934-M 8 A4C<br>8196-LINKSGEWINDE |     |
| 10       | 111 2858  | 2          | SECHSKANTMUTTER    | HEX-NUT         | ECROU 6 PANS       | TUERCA HEXAGONAL   | M12 DIN 934-M 8 A4C                            |     |
| 11       | 232 5877  | 1          | ZUGFEDER           | DRAW SPRING     | RESSORT TRACTION   | RESORTE TRACCION   |  | 01  |
| 12       | 232 0892  | 1          | RUECKHOLFEDER      | RETURN SPRING   | RESSORT DE RAPPEL  | RESORTE ANTAGONIST |  | 01  |
| 13       | 110 7554  | 4          | SCHEIBE            | DISC/PANE/PLATE | RONDELLE/DISQUE    | DISCO              | 13-5DIN 433-ST-A4C                             |     |
| 14       | 338 7776  | 4          | SICHERUNGSSTIFF    | LOCKING PIN     | GOUPILLE D ARRET   | PERNO AFIANZADOR   | 1125-30-01-16                                  | 01  |
| 15       | 338 6958  | 2          | STELLSCHRAUBE      | SET SCREW       | VIS DE REGLAGE     | TORNILLO GRADUAC.  | 1055-33-08-24                                  |     |
| 16       | 116 8225  | 2          | SCHMIERNIPPEL      | LUBE FITTING    | RACCORD GRAISSEUR  | NIPLE LUBRICACION  | SA 6H 336D                                     | 01  |
| 17       | 110 7740  | 1          | SICHERUNGSRING     | CIRCLIP         | CIRCLIP            | CIRCLIP            | 28X1,5 DIN 471                                 |     |
| 18       | 232 1015  | 2          | GUMMPUFFER         | RUBBER PAD      | TAMPON CAOUTCHOUC  | TOPE CAUCHO        |  | 01  |
| 19       | 233 2644  | 1          | BOLZEN             | PIN/BOLT/STUD   | BOULON/AXE         | BULON              |  |     |
| 20       | 110 4895  | 1          | ZYLINDERKERBSTIFT  | NOTCHED PIN     | GOUPILLE CYL-CRANT | PERNO CIL-RANURADO | 8 X 80DIN 1470                                 |     |

1005-30 500 6056

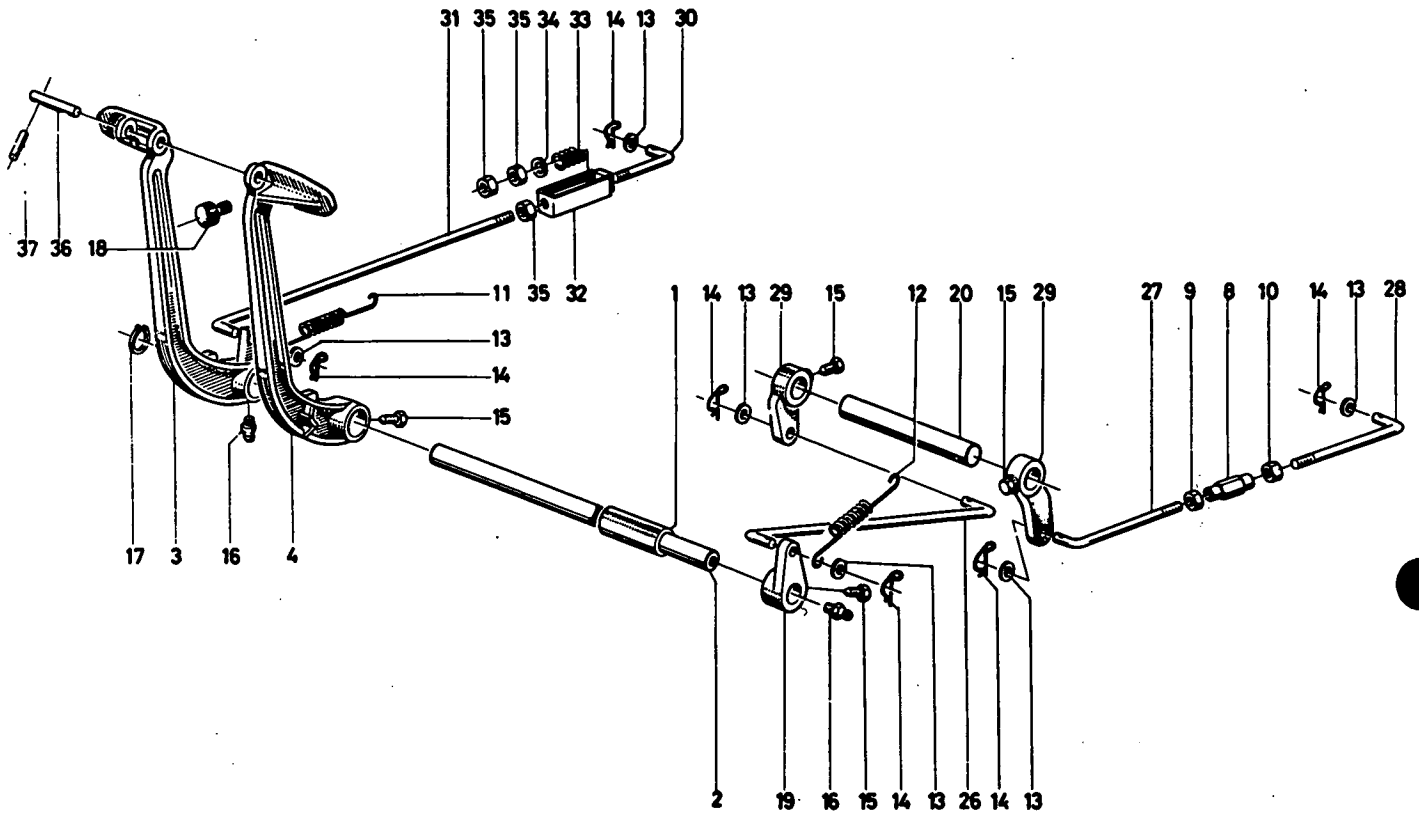

| Bild Nr. | Teil-Nr. | Stück-Zahl | Deutsch            | English            | Français          | Español            | Numer / Bemerkung                               | ETK |
|----------|----------|------------|--------------------|--------------------|-------------------|--------------------|---|-----|
| 1        | 231 9689 | 1          | BUCHSE             | BUSH               | DOUILLE           | CASQUILLO          |   |     |
| 2        | 231 9690 | 1          | BREMSWELLE         | BRAKE SHAFT        | ARBRE DE FREIN    | EJE FRENO          |   |     |
| 3        | 233 2477 | 1          | BREMSPEDAL         | BRAKE PEDAL        | PEDALE DE FREIN   | PEDAL FRENO        |   |     |
| 4        | 231 1637 | 1          | BREMSPEDAL         | BRAKE PEDAL        | PEDALE DE FREIN   | PEDAL FRENO        |   |     |
| 8        | 111 5350 | 1          | SPANNSCHLOSSMUTTER | TURNBUCKLE         | ECROU TENDEUR     | TUERCA CIERRE TENS | M12 DIN 934                                     |     |
| 9        | 111 2863 | 1          | SECHSKANTMUTTER    | HEX-NUT            | ECROU 6 PANS      | TUERCA HEXAGONAL   | M12 LINKS DIN 934-M 8 A4C<br>8196, LINKSGEWINDE |     |
| 10       | 111 2858 | 1          | SECHSKANTMUTTER    | HEX-NUT            | ECROU 6 PANS      | TUERCA HEXAGONAL   | M12 DIN 934-M 8 A4C                             |     |
| 11       | 232 5877 | 1          | ZUGFEDER           | DRAW SPRING        | RESSORT TRACTION  | RESORTE TRACCION   |   | 01  |
| 12       | 232 0872 | 1          | RUECKHOLFEDER      | RETURN SPRING      | RESSORT DE RAPPEL | RESORTE ANTAGONIST |   | 01  |
| 13       | 110 7554 | 6          | SCHIEBE            | DISC/PANE/PLATE    | RONDELLE/DISQUE   | DISCO              | 13,5 DIN 933-ST-A4C                             |     |
| 14       | 338 7776 | 6          | SICHERUNGSSTIFT    | LOCKING PIN        | GOUPILLE D'ARRET  | PERNO AFIANZADOR   | 1125-30-01-16                                   | 01  |
| 15       | 338 6958 | 4          | STELLSCHRAUBE      | SET SCREW          | VIS DE REGLAGE    | TORNILLO GRADUAC.  | 1055-33-08-29                                   |     |
| 16       | 116 8225 | 2          | SCHMIERNIPPEL      | LUBE FITTING       | RACCORD GRAISSEUR | NIPLE LUBRICACION  | SA 8H 3360                                      | 01  |
| 17       | 110 7740 | 1          | SICHERUNGSRING     | CIRCLIP            | CIRCLIP           | CIRCLIP            | 28X1,5 DIN 971                                  |     |
| 18       | 232 1035 | 2          | GUMMIPUFFER        | RUBBER PAD         | TAMPON CAOUTCHOUC | TOPE CAUCHO        |   | 01  |
| 19       | 232 5576 | 1          | HEBEL              | LEVER/ARM          | LEVIER            | PALANCA            |   |     |
| 20       | 230 6264 | 1          | WELLE              | SHAFT              | ARBRE             | EJE/ARBOL          |   |     |
| 26       | 233 3812 | 1          | ZUGSTANGE          | PULLROD            | TIRANT            | BARRA TRACCION     |   |     |
| 27       | 233 3810 | 1          | ZUGSTANGE          | PULLROD            | TIRANT            | BARRA TRACCION     |   |     |
| 28       | 233 3811 | 1          | ZUGSTANGE          | PULLROD            | TIRANT            | BARRA TRACCION     |   |     |
| 29       | 230 6262 | 2          | HEBEL              | LEVER/ARM          | LEVIER            | PALANCA            |   |     |
| 30       | 237 2441 | 1          | ZUGSTANGE          | PULLROD            | TIRANT            | BARRA TRACCION     |   |     |
| 31       | 237 2442 | 1          | ZUGSTANGE          | PULLROD            | TIRANT            | BARRA TRACCION     |   |     |
| 32       | 237 0877 | 1          | AUSGLEICHGEHAUSE   | HOUSING            | CARTER DE DIEFFER | CAJA COMPENS.      |   |     |
| 33       | 237 2443 | 1          | DRUCKFEDER         | COMPRESSION SPRING | RESSORT DE COMPR  | RESORTE PRESION    |   | 01  |

| Bild<br>Nr. | Teil-Nr. | Stück-<br>Zahl | Deutsch           | English         | Français           | Español            | Nummer/Bemerkung    | ETK |
|-------------|----------|----------------|-------------------|-----------------|--------------------|--------------------|---------------------|-----|
| 34          | 110 7310 | 1              | SCHEIBE           | DISC/PANE/PLATE | RONDELLE/DISQUE    | DISCO              | A13 DIN 125-ST-A4C  |     |
| 35          | 111 3152 | 3              | SECHSKANTMUTTER   | HEX-NUT         | ECROU 6 PANS       | TUERCA HEXAGONAL   | M12 DIN 934-M5S-A4C |     |
| 36          | 233 2644 | 1              | BOLZEN            | PIN/BOLT/STUD   | BOULON/AXE         | BULON              |                     |     |
| 37          | 110 4695 | 1              | ZYLINDERKERBSTIFT | NOTCHED PIN     | GOUPILLE CYL-CRANT | PERNO CIL-RANURADO | 8 X 80DIN 1470      |     |

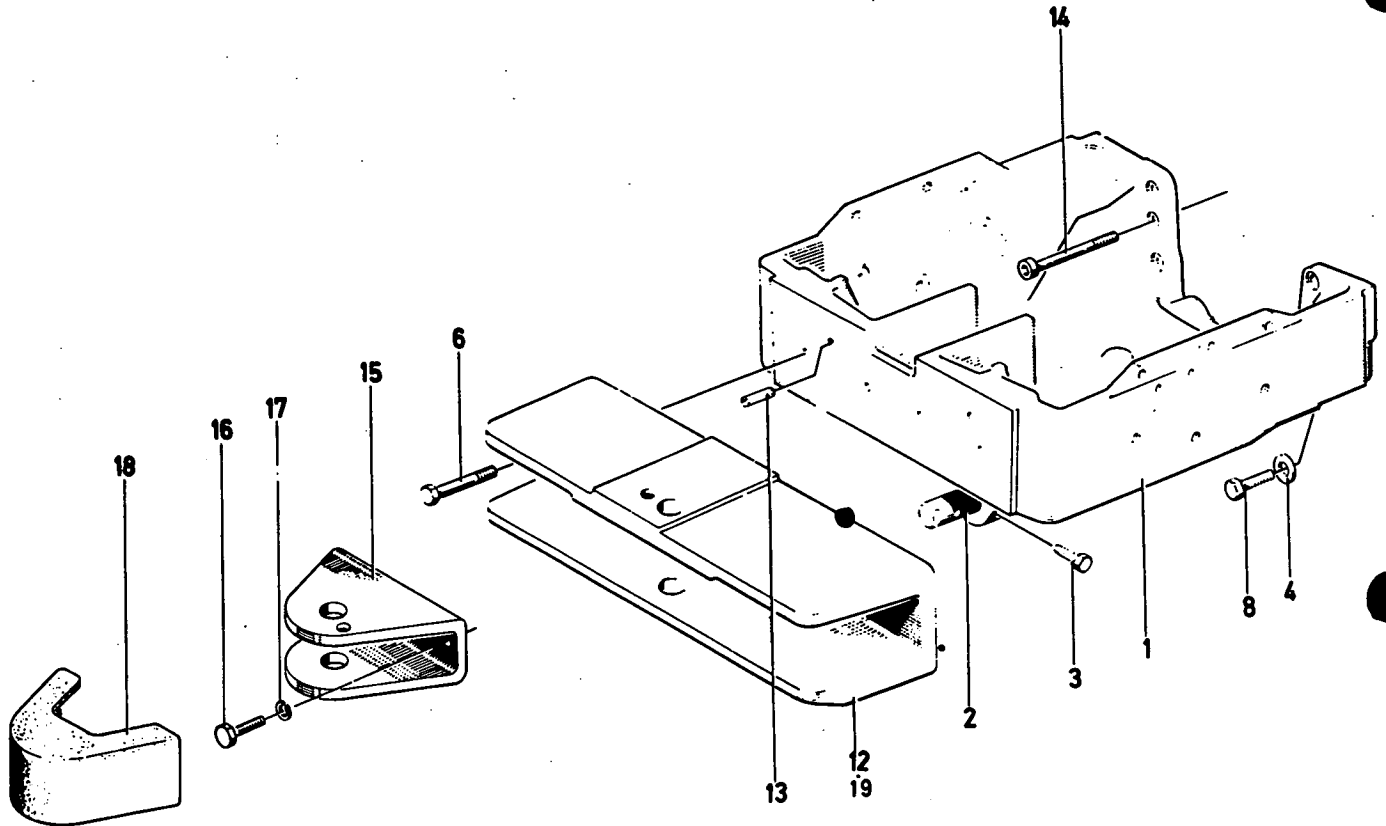

1001-32 500 4211

| Bild-Nr | Teile-Nr. | Stück-Zahl | Deutsch           | English           | Français          | Español            | Nummer/Bemerkung           | ETK |
|---------|-----------|------------|-------------------|-------------------|-------------------|--------------------|----------------------------|-----|
| 1       | 233 2429  | 1          | LAGERBOCK         | BRACKET           | CHEVALET SUPPORT  | CABALLETE SOPORTE  |                            |     |
| 2       | 338 8954  | 1          | BOLZEN            | PIN/BOLT/STUD     | BOULON/AXE        | BULON              | 1136-32-01-02              |     |
| 3       | 338 6862  | 1          | KLEMSCHRAUBE      | CLAMPING SCREW    | VIS DE SERRAGE    | TORNILLO APRIETO   | 1055-25-01-04              |     |
| 4       | 338 9301  | 1          | SCHLEIFE          | DISC/PANE/PLATE   | RONDELLE/DISQUE   | DISCO              | 1145-32-01-14              |     |
| 6       | 111 2631  | 4          | SECHSKANTSCHRAUBE | HEX-BOLT          | VIS 6 PANS        | TORNILLO HEXAGONAL | M14X 45 DIN 933-M 8-8 A4C  |     |
| 8       | 110 1922  | 2          | SECHSKANTSCHRAUBE | HEX-BOLT          | VIS 6 PANS        | TORNILLO HEXAGONAL | M16X 90 DIN 933-M10-9 VZKC |     |
| 12      | 233 2431  | 1          | TRAEGER           | SUPPORT/CARRIER   | SUPPORT/POUTRE    | VIGA/SOPORTE       | 8355 WAHLWEISE POS.19      |     |
| 13      | 111 5503  | 2          | SPANNHUELSE       | DOWEL SLEEVE      | DOUILLE SERRAGE   | CASQUILLO FIADOR   | 13 X 45DIN 1461            |     |
| 14      | 110 2298  | 4          | ZYLINDERSCHRAUBE  | CHEESE-HEAD SCREW | VIS TETE CYLINDR. | TORN-CBZA-CILINDR. | M14X 110DIN 912-10-9-A4C   |     |
| 15      | 237 7119  | 1          | FANGHAUL          | CLEVIS            | BOUCHE D ARRET    | BOCA ENCASTRE      |                            |     |
| 16      | 111 2624  | 2          | SECHSKANTSCHRAUBE | HEX-BOLT          | VIS 6 PANS        | TORNILLO HEXAGONAL | M14X 40 DIN 933-M 8-8 A4C  |     |
| 17      | 110 2802  | 2          | FEDERRING         | SPRING LOCKWASHER | RONDELLE GROUER   | ARANDELA ELASTICA  | A 14 DIN 128 A4C           |     |
| 18      | 237 7120  | 1          | SCHUTZKAPPE       | CAP               | CAPUCHON PROTECT  | SOMBRERETE PROTEC. |                            |     |
| 19      | 238 4813  | 1          | TRAEGER           | SUPPORT/CARRIER   | SUPPORT/POUTRE    | VIGA/SOPORTE       | 8355 WAHLWEISE POS.12      |     |



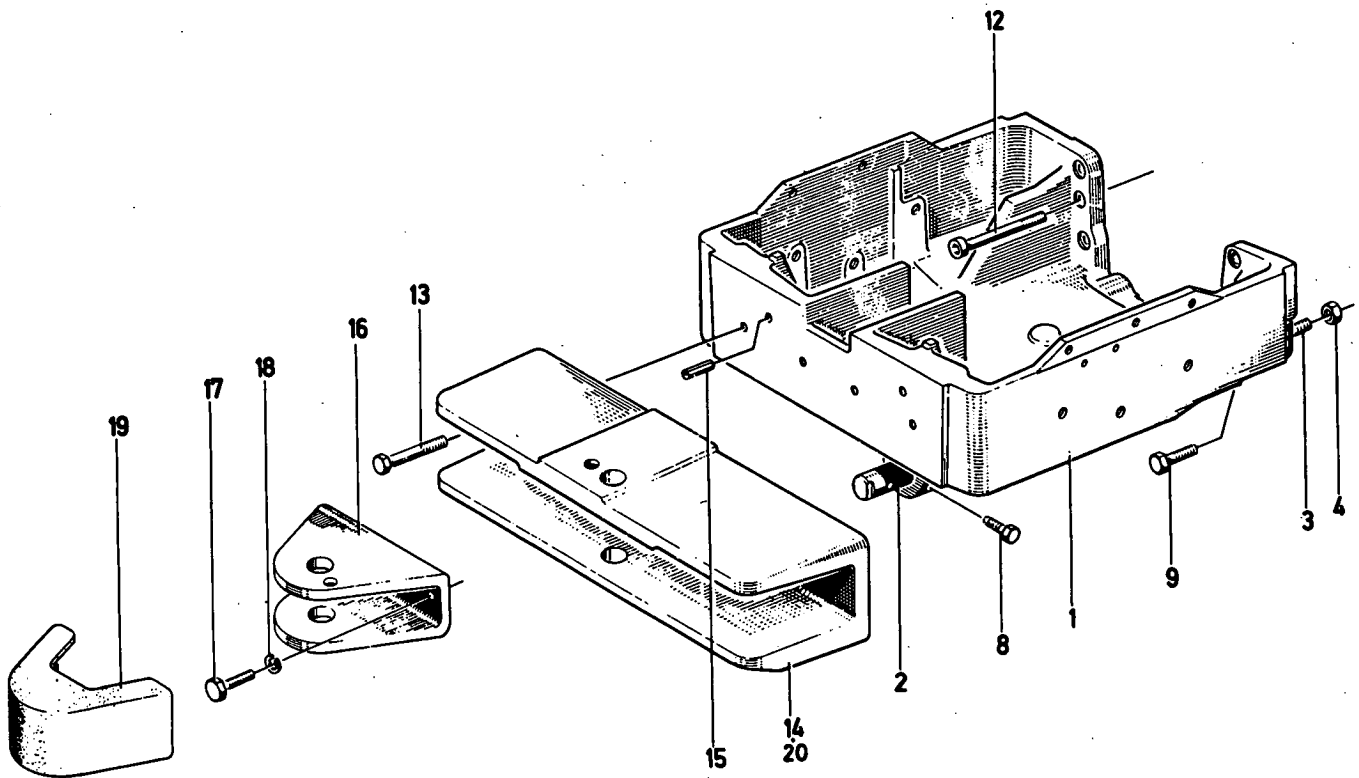

1003-32 500 4265

| Bild Nr. | Teile-Nr. | Stück-Zahl | Deutsch           | English           | Français          | Español            | Nummer / Bemerkung                                 | ETK |
|----------|-----------|------------|-------------------|-------------------|-------------------|--------------------|--|-----|
| 1        | 233 4037  | 1          | LAGERBOCK         | BRACKET           | CHEVALET SUPPORT  | CABALLETE SOPORTE  |  |     |
| 2        | 230 1515  | 1          | BOLZEN            | PIN/BOLT/STUD     | BOULON/AXE        | BULON              |  |     |
| 3        | 110 1007  | 2          | SKT-PASSSCHRAUBE  | FITTED BOLT       | VIS AJUST 6 PANS  | TORN-HEX-CALIBR.   | M18X2 X 85 DIN 609-M 8-8 VZKC                      |     |
| 4        | 111 2908  | 2          | SECHSKANTMUTTER   | HEX-NUT           | ECROU 6 PANS      | TUERCA HEXAGONAL   | M18 K2 DIN 934-M 8 VZKC                            |     |
| 8        | 230 9386  | 1          | KLEMMSCHRAUBE     | CLAMPING SCREW    | VIS DE SERRAGE    | TORNILLO APRIETO   | M18X2 X 85 DIN 609-M 8-8 VZKC                      |     |
| 9        | 110 1923  | 1          | SECHSKANTSCHRAUBE | HEX-BOLT          | VIS 6 PANS        | TORNILLO HEXAGONAL | M16X 95 DIN 933-M10-9 A4C                          |     |
| 12       | 110 2298  | 4          | ZYLINDERSCHRAUBE  | CHEESE-HEAD SCREW | VIS TETE CYLINDR. | TORN-CBZA-CILINDR. |  |     |
| 13       | 111 2631  | 4          | SECHSKANTSCHRAUBE | HEX-BOLT          | VIS 6 PANS        | TORNILLO HEXAGONAL | M14X 45 DIN 933-M 8-8 A4C                          |     |
| 14       | 233 2431  | 1          | TRAEGER           | SUPPORT/CARRIER   | SUPPORT/POUTRE    | VIGA/SOPORTE       | M14X 45 DIN 933-M 8-8 A4C<br>8355-WAHLWEISE POS-20 |     |
| 15       | 111 5503  | 2          | SPANNHUELSE       | DOWEL SLEEVE      | DOUILLE SERRAGE   | CASQUILLO FIADOR   | 13 X 45 DIN 1481                                   |     |
| 16       | 237 7119  | 1          | FANGMAUL          | CLEVIS            | BOUCHE D ARRET    | BOCA ENCASTRE      |  |     |
| 17       | 111 2624  | 2          | SECHSKANTSCHRAUBE | HEX-BOLT          | VIS 6 PANS        | TORNILLO HEXAGONAL | M14X 40 DIN 933-M 8-8 A4C                          |     |
| 18       | 110 2802  | 2          | FEDERRING         | SPRING LOCKWASHER | RONDELLE GROWER   | ARANDELA ELASTICA  | A 14 DIN 128 A4C                                   |     |
| 19       | 237 7120  | 1          | SCHUTZKAPPE       | CAP               | CAPUCHON PROTECT  | SOMBRERETE PROTEC. |  |     |
| 20       | 238 4813  | 1          | TRAEGER           | SUPPORT/CARRIER   | SUPPORT/POUTRE    | VIGA/SOPORTE       | 8355-WAHLWEISE POS- 14                             |     |

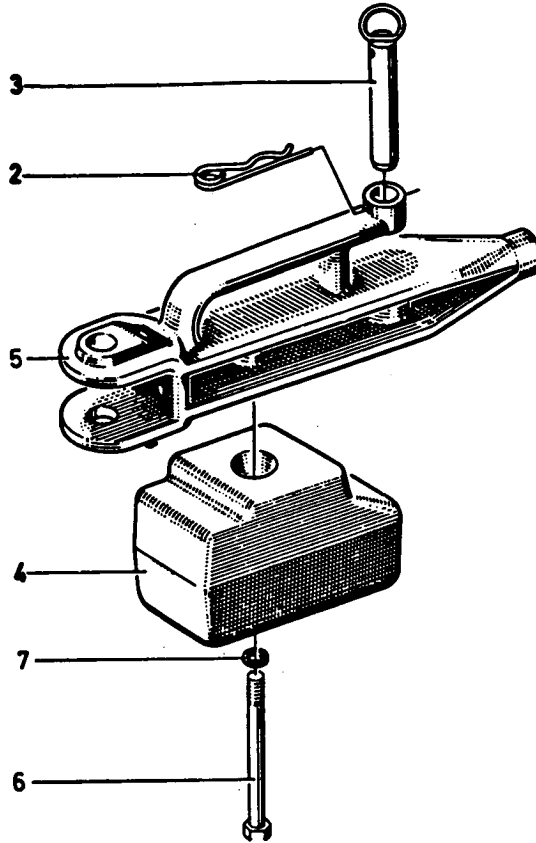

1001-32 500 2995

| Bild Nr. | Teile-Nr. | Stück-Zahl | Deutsch           | English        | Français           | Español            | Nummer/Bemerkung                        | ETK |
|----------|-----------|------------|-------------------|----------------|--------------------|--------------------|---|-----|
| 2        | 110 2848  | 1          | STECKER           | PLUG           | FICHE DE CONTACT   | CLAVIJA ENCHUFE    | 7 DIN11024 VZKC                         |     |
| 3        | 232 5644  | 1          | STECKBOLZEN       | COTTER PIN     | CHEVILLE           | BULON ENCHUFE      |   |     |
| 4        | 232 5647  | 1          | BALLASTGEWICHT    | BALLAST WEIGHT | CONTREPOIDS/LEST   | PESO DE LASTRE     |   |     |
| 5        | 233 4428  | 1          | RANGIERKUPPLUNG   | TOWING CLEVIS  | MANILLE DE REFOULM | ACOPLE MANIOBRAS   | M10X 130 DIN 931- 8.8-A4C<br>B182, KURZ |     |
| 6        | 112 4803  | 1          | SECHSKANTSCHRAUBE | HEX-BOLT       | VIS 6 PANS         | TORNILLO HEXAGONAL | M10X 130 DIN 931- 8.8-A4C               |     |
| 7        | 116 9694  | 1          | SICHERUNGSSCHEIBE | LOCKING WASHER | RONDELLE SECURITE  | ARANDELA SEGURIDAD | 10 H 2203                               |     |

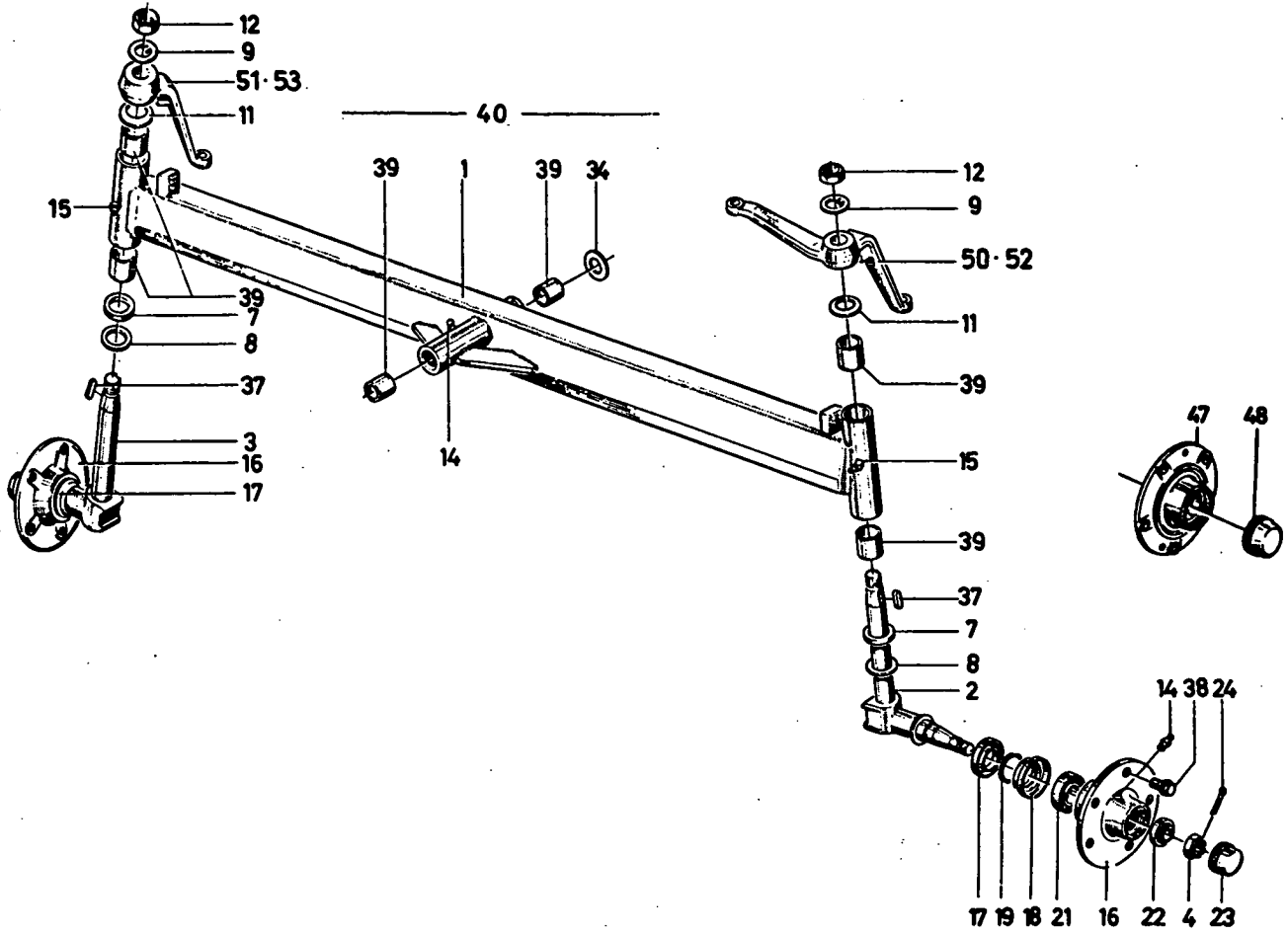

1145-33 500 6101

| Bld. Nr. | Teil-Nr. | Stück-Zahl | Deutsch            | English            | Français           | Español           | Nummer/Bemerkung                   | ETK |
|----------|----------|------------|--------------------|--------------------|--------------------|-------------------|------------------------------------|-----|
| 1        | 338 7331 | 1          | ACHSKÖRPER         | AXLE BODY          | CORPS ESSIEU       | CUERPO EJE        | 1145-33-38-10                      |     |
| 2        | 338 7317 | 1          | LENKSCHENKEL       | STEERING KNUCKLE   | LEV CDE DE LA FUSE | PIVOTE DIRECCION  | 1145-33-27-10<br>8195-LINKS        |     |
| 3        | 338 7320 | 1          | LENKSCHENKEL       | STEERING KNUCKLE   | LEV CDE DE LA FUSE | PIVOTE DIRECCION  | 1145-33-28-10<br>8267-RECHTS       |     |
| 4        | 111 3283 | 2          | KRONENMUTTER       | CASTLE NUT         | ECROU CRENELE      | TUERCA CORONA     | M24X1,5 DIN 937-55                 |     |
| 7        | 338 7303 | 2          | BRUCKSCHEIBE       | THRUST PLATE       | RONDELLE DE BUTEE  | ARANDELA PRESION  | 1145-33-01-11                      |     |
| 8        | 230 7306 | 2          | SCHIEBE            | DISC/PANE/PLATE    | RONDELLE/DISQUE    | DISCO             | 1145-33-01-14                      |     |
| 9        | 338 8447 | 2          | SICHERUNGSBLECH    | LOCKING PLATE      | TOLE DE SECURITE   | CHAPA SEGURIDAD   | 1135-33-01-23                      |     |
| 11       | 338 8444 | 2          | TELLERFEDER        | CUP SPRING         | RESSORT BELLEVILLE | RESORTE DE PLATO  | 1135-33-01-13                      |     |
| 12       | 111 3206 | 2          | SECHSKANTMUTTER    | HEX-NUT            | ECROU 6 PANS       | TUERCA HEXAGONAL  | M27X1,5 DIN 936-M6S-PHOSPH         |     |
| 14       | 116 8255 | 3          | KEGELSCHMIERNIPPEL | LUBE FITTING       | GRAISSEUR CONIQUE  | ENGRASADOR CONICO | A 55 H 3481                        |     |
| 15       | 116 8227 | 2          | KEGELSCHMIERNIPPEL | LUBE FITTING       | GRAISSEUR CONIQUE  | ENGRASADOR CONICO | SB 8H 3360                         |     |
| 14       | 338 7308 | IP         | NABE               | HUB                | MOYEU              | CUBO              | 1145-33-01-22<br>8285-SIEHE POS.47 |     |
| 17       | 339 0472 | 2          | DICHTRING          | WASHER             | BAGUE D ETANCHEITE | ANILLO DE JUNTA   | 1155-33-13-28                      | 01  |
| 18       | 339 0470 | 2          | DICHTRING          | WASHER             | BAGUE D ETANCHEITE | ANILLO DE JUNTA   | 1155-33-13-26                      | 01  |
| 19       | 339 7307 | 2          | DICHTRING          | WASHER             | BAGUE D ETANCHEITE | ANILLO DE JUNTA   | 1145-33-01-25                      | 01  |
| 21       | 110 7757 | 2          | KEGELROLLENLAGER   | TAP-ROLLER BEARING | ROULEM A ROUL CON  | COJ-RODIL-CONICOS | 30207 DIN 720                      | 01  |
| 22       | 110 7755 | 2          | KEGELROLLENLAGER   | TAP-ROLLER BEARING | ROULEM A ROUL CON  | COJ-RODIL-CONICOS | 30205 DIN 720                      | 01  |
| 23       | 338 6462 | 2          | KAPSEL             | CAPSULE            | CAPSULE            | CAPSULA           | 1055-33-08-32                      |     |
| 24       | 110 6472 | 2          | SPLINT             | SPLIT PIN          | GOUPILLE FENDUE    | PASADOR ALETAS    | 5 X 45DIN 94                       |     |
| 34       | 233 0834 | SZ         | SCHIEBE            | DISC/PANE/PLATE    | RONDELLE/DISQUE    | DISCO             | 8076-SIEHE POS.950-951             |     |
| 37       | 237 6233 | 2          | PASSFEDER          | KEY                | CLAVETTE ENCASTREE | LENGUETA AJUSTE   |                                    |     |
| 38       | 338 7372 | 10         | RADBOLZEN          | PIN                | BOULON DE ROUE     | BULON RUEDA       | 1110-33-01-13                      |     |
| 39       | 338 7314 | 6          | BUCHSE             | BUSH               | DOUILLE            | CASQUILLO         |                                    |     |
| 40       | 231 5262 | 1          | VORDERACHSE        | FRONT AXLE         | ESSIEU AVANT       | EJE DELANTERO     | 8328-UNGFEDERT                     |     |

| Bld<br>Nr. | Teil-Nr. | Stück-<br>Zahl | Deutsch       | English         | Français           | Español            | Nummer/Bemerkung                                     | ETK |
|------------|----------|----------------|---------------|-----------------|--------------------|--------------------|--|-----|
| 47         | 238 1381 | 2              | NABE          | HUB             | ROYEU              | CUBO               | B041-BEI ERSTMALIGEM ERSATZ<br>POS-48+14 MITLIEFERN. |     |
| 48         | 238 1373 | 2              | KAPPE         | CAP             | CAPUCHON/CALOTTE   | SOMBREER./CAPUCHON | B233-NUR MIT POS-47 VERWENDEN                        |     |
| 50         | 338 9321 | 1              | LENKSPURHEBEL | STEERING ARM    | LEV ATTAQUE FUSEE  | PALANCA BIELA ACOP | 1145-33-29-01  |     |
| 51         | 338 9323 | 1              | LENKHEBEL     | STEERING ARM    | LEVIER DE DIRECTIO | PALANCA DIRECCION  | 1145-33-30-01  |     |
| 52         | 338 9333 |                | LENKSPURHEBEL | STEERING ARM    | LEV ATTAQUE FUSEE  | PALANCA BIELA ACOP | 1145-33-41-01<br>B106-FUER HYDROLENKUNG              |     |
| 53         | 338 9335 | 1              | LENKHEBEL     | STEERING ARM    | LEVIER DE DIRECTIO | PALANCA DIRECCION  | 1145-33-42-01<br>B106-FUER HYDROLENKUNG              |     |
| 450        | 233 0836 | 1              | SCHEIBE       | DISC/PANE/PLATE | RONDELLE/DISQUE    | DISCO              | A 3.0 MM   |     |
| 451        | 233 0837 | 1              | SCHEIBE       | DISC/PANE/PLATE | RONDELLE/DISQUE    | DISCO              | A 2.0 MM   |     |

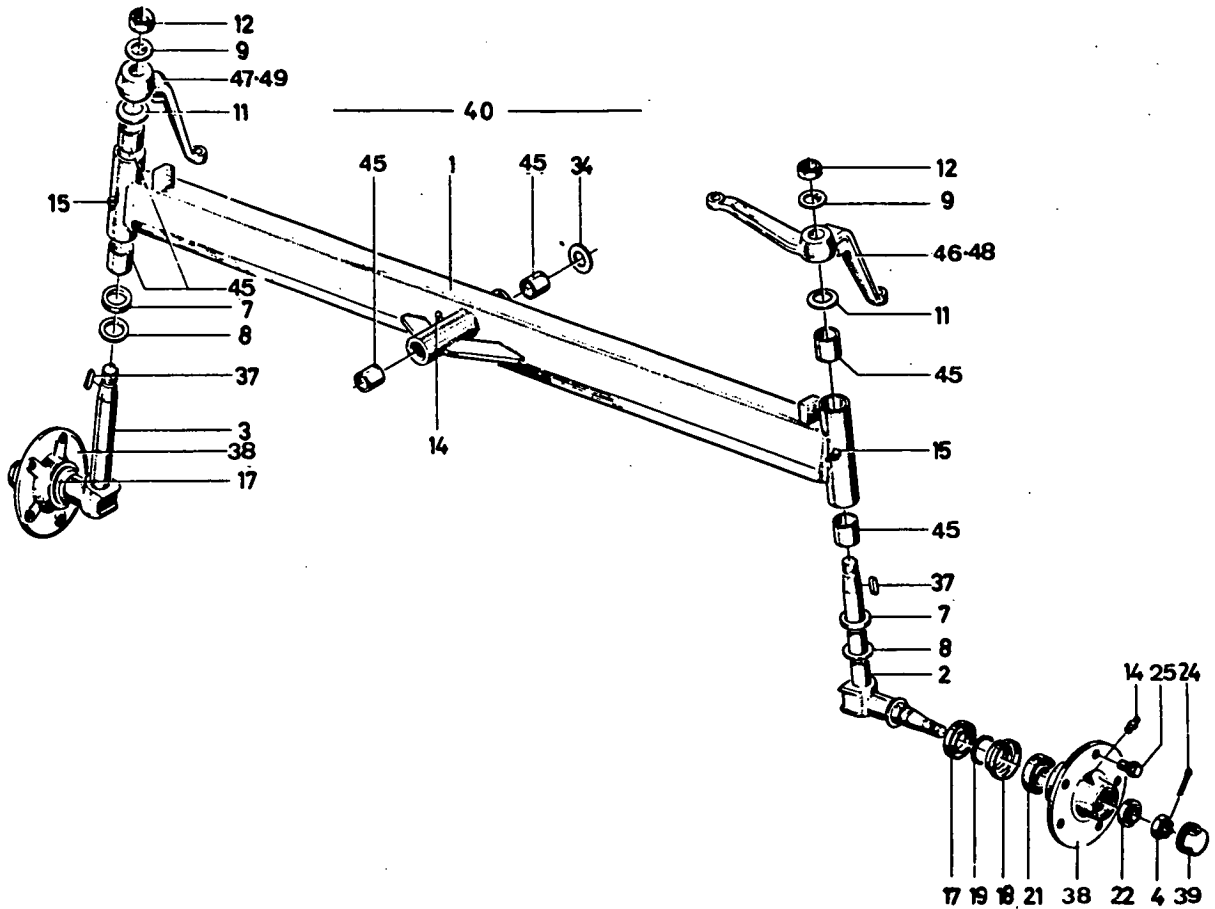

1145-33 502 0149

| Bad Nr. | Teile-Nr. | Stück-Zahl | Deutsch            | English            | Français           | Español            | Nummer/Bemerkung                       | ETK |
|---------|-----------|------------|--------------------|--------------------|--------------------|--------------------|--|-----|
| 1       | 338 9331  | 1          | ACHSKÖRPER         | AXLE BODY          | CORPS ESSIEU       | CUERPO FJE         | 1145-33-38-10<br>8211-MIT POS.45       |     |
| 2       | 338 9319  | 1          | LENKSCHENKEL       | STEERING KNUCKLE   | LEV CDE DE LA FUSE | PIVOTE BIRECCION   | 1145-33-27-10<br>9195-LINKS            |     |
| 3       | 338 9320  | 1          | LENKSCHENKEL       | STEERING KNUCKLE   | LEV CDE DE LA FUSE | PIVOTE BIRECCION   | 1145-33-28-10<br>8267-RECHTS           |     |
| 4       | 111 3283  | 2          | KRONENPUTTER       | CASTLE NUT         | ECROU CRENELE      | TUERCA CORONA      | M24X1,5 DIN 937-55                     |     |
| 7       | 338 9303  | 2          | DRUCKSCHEIBE       | THRUST PLATE       | RONDELLE DE BUTEE  | ARANDELA PRESION   | 1145-33-01-13                          |     |
| 8       | 338 9306  | 2          | SCHEIBE            | DISC/PANE/PLATE    | RONDELLE/DISQUE    | DISCO              | 1145-33-01-14                          |     |
| 9       | 338 8449  | 2          | SICHERUNGSBLECH    | LOCKING PLATE      | TOLE DE SECURITE   | CHAPA SEGURIDAD    | 1135-33-01-23                          |     |
| 11      | 338 8444  | 2          | TELLERFEDER        | CUP SPRING         | RESSORT BELLEVILLE | RESORTE DE PLATO   | 1135-33-01-13                          |     |
| 12      | 111 3206  | 2          | SECHSKANTMUTTER    | HEX-NUT            | ECROU 6 PANS       | TUERCA HEXAGONAL   | M 27X1,5 DIN 934 5-2                   |     |
| 14      | 116 8225  | 3          | KEGELSCHMIERNIPPEL | LUBE FITTING       | GRAISSEUR CONIQUE  | ENGRASADOR CONICO  | SA 8M 3350                             |     |
| 15      | 116 8227  | 4          | KEGELSCHMIERNIPPEL | LUBE FITTING       | GRAISSEUR CONIQUE  | ENGRASADOR CONICO  | SB 8M 3350                             |     |
| 17      | 339 0472  | 2          | DICHTRING          | WASHER             | BAGUE D ETANCHEITE | ANILLO DE JUNTA    | 1155-33-13-25                          | 01  |
| 18      | 339 0470  | 2          | DICHTRING          | WASHER             | BAGUE D ETANCHEITE | ANILLO DE JUNTA    | 1155-33-13-26                          | 01  |
| 19      | 338 9309  | 2          | DICHTRING          | WASHER             | BAGUE D ETANCHEITE | ANILLO DE JUNTA    | 1145-33-01-25                          | 01  |
| 21      | 110 9957  | 2          | KEGELROLLENLAGER   | TAP-ROLLER BEARING | ROULEM A ROUL CON  | COJ-RODIL-CONICOS  | 30207 914 720                          | 01  |
| 22      | 110 9955  | 2          | KEGELROLLENLAGER   | TAP-ROLLER BEARING | ROULEM A ROUL CON  | COJ-RODIL-CONICOS  | 30205 914 720                          | 01  |
| 24      | 110 6472  | 2          | SPLINT             | SPLIT PIN          | GOUPILLE FENDUE    | PASADOR ALETAS     | 5 X 45DIN 94                           |     |
| 25      | 338 7372  | 10         | RADBOLZEN          | PIN                | BOULON DE ROUE     | BULON RUEDA        | 1110-33-01-13                          |     |
| 34      | 233 0834  | SZ         | SCHEIBE            | DISC/PANE/PLATE    | RONDELLE/DISQUE    | DISCO              | 8076-EINZELTEILE SIEHE POS-<br>950-951 |     |
| 37      | 237 6233  | 2          | PASSFEDER          | KEY                | CLAVETTE ENCASTREE | LENGUETA AJUSTE    |  |     |
| 38      | 238 1381  | 2          | NABE               | HUB                | MOYEU              | CUBO               |  |     |
| 39      | 238 1373  | 2          | KAPPE              | CAP                | CAPUCHON/CALOTTE   | SOMBRETE-/CAPUCHON |  |     |
| 40      | 238 1386  | 1          | VORDERACHSE        | FRONT AXLE         | ESSIEU AVANT       | EJE DELANTERO      | 9328-UNGEFEDERT                        |     |

| Stk<br>Nr. | Teil-Nr. | Stück-<br>Zahl | Deutsch       | English         | Français           | Español            | Nummer/Bemerkung                        | ETK |
|------------|----------|----------------|---------------|-----------------|--------------------|--------------------|---|-----|
| 45         | 338 9314 | 6              | BUCHSE        | BUSH            | DOUILLE            | CASQUILLO          | 1145-33-24-02                           |     |
| 46         | 338 9321 | 1              | LENKSPURHEBEL | STEERING ARM    | LEV ATTAQUE FUSEE  | PALANCA BIELA ACOP | 1145-33-29-03                           |     |
| 47         | 338 9323 | 1              | LENKHEBEL     | STEERING ARM    | LEVIER DE DIRECTIO | PALANCA DIRECCION  | 1145-33-30-03                           |     |
| 48         | 338 9333 | 1              | LENKSPURHEBEL | STEERING ARM    | LEV ATTAQUE FUSEE  | PALANCA BIELA ACOP | 1145-33-41-03<br>B106, FUER HYDRLENKUNG |     |
| 49         | 338 9335 | 1              | LENKHEBEL     | STEERING ARM    | LEVIER DE DIRECTIO | PALANCA DIRECCION  | 1145-33-42-03<br>B106, FUER HYDRLENKUNG |     |
| 450        | 233 0836 | 1              | SCHEIBE       | DISC/PANE/PLATE | RONDELLE/DISQUE    | DISCO              | D 1.0 MM                                |     |
| 451        | 233 0837 | 1              | SCHEIBE       | DISC/PANE/PLATE | RONDELLE/DISQUE    | DISCO              | D 2.0 MM                                |     |

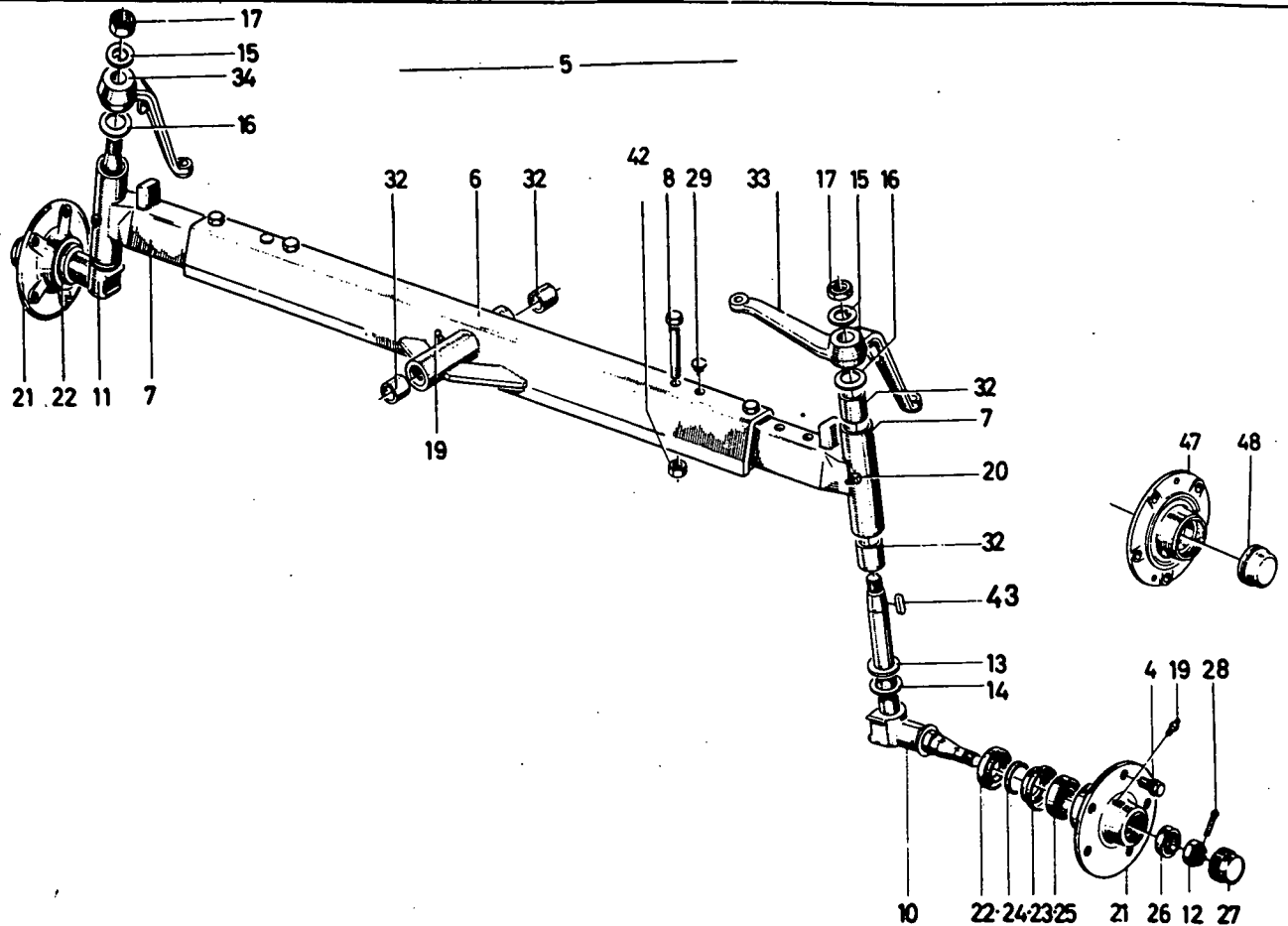

1145-33 500 6061

| Bil. Nr. | Teil-Nr. | Stück-Zahl | Deutsch            | Englisch           | Francés            | Español            | Nummer/Bemerkung                   | ETK |
|----------|----------|------------|--------------------|--------------------|--------------------|--------------------|------------------------------------|-----|
| 4        | 338 7372 | 10         | RADBOLZEN          | PIN                | BOULON DE ROUE     | BULON RUEDA        | 1110-33-01-13                      |     |
| 5        | 338 7310 | 1          | VORDERACHSE        | FRONT AXLE         | ESSIEU AVANT       | EJE DELANTERO      | 1145-33-02-10                      |     |
| 6        | 338 7326 | 1          | ACHSBRUECKE        | AXLE BRACKET       | PONT ESSIEU        | PUNTE EJE          | 1145-33-31-10<br>8211-MIT POS-32   |     |
| 7        | 338 7328 | 2          | FAUSTARM           | END PIECE          | BRAS               | PIVOTE DIRECC.     | 1145-33-33-10<br>8211-MIT POS-32   |     |
| 8        | 111 3763 | 4          | SECHSKANTSCHRAUBE  | HEX-BOLT           | VIS 6 PANS         | TORNILLO HEXAGONAL | M16X1,5 X 70 DIN 913-M 8-8         |     |
| 10       | 338 7314 | 1          | LENKSCHENKEL       | STEERING KNUCKLE   | LEV CDE DE LA FUSE | PIVOTE DIRECCION   | 1145-33-27-10<br>8175-LINKS        |     |
| 11       | 338 7320 | 1          | LENKSCHENKEL       | STEERING KNUCKLE   | LEV CDE DE LA FUSE | PIVOTE DIRECCION   | 1145-33-28-10<br>8267-RECHTS       |     |
| 12       | 111 3283 | 2          | KRONENMUTTER       | CASTLE NUT         | ECROU CREMELE      | TUERCA CORONA      | M24X1,5 DIN 937-SS                 |     |
| 13       | 338 7303 | 2          | BRUCKSCHEIBE       | THRUST PLATE       | RONDELLE DE BUTEE  | ARANDELA PRESION   | 1145-33-03-11                      |     |
| 14       | 338 7306 | 2          | SCHWEIBE           | DISC/PANE/PLATE    | RONDELLE/DISQUE    | DISCO              | 1145-33-03-14                      |     |
| 15       | 338 8444 | 2          | SICHERUNGSBLECH    | LOCKING PLATE      | TOLE DE SECURITE   | CHAPA SEGURIDAD    | 1135-33-01-23                      |     |
| 16       | 338 8444 | 2          | TELLERFEDER        | CUP SPRING         | RESSORT BELLEVILLE | RESORTE DE PLATO   | 1135-33-01-13                      |     |
| 17       | 111 3206 | 2          | SECHSKANTMUTTER    | HEX-NUT            | ECROU 6 PANS       | TUERCA HEXAGONAL   | M27X1,5 DIN 936-M6S-PHOSPH         |     |
| 19       | 116 8225 | 3          | KEGELSCHMIERNIPPEL | LUBE FITTING       | GRAISSEUR CONIQUE  | ENGRASADOR CONICO  | SA 8M 3360                         |     |
| 20       | 116 8227 | 2          | KEGELSCHMIERNIPPEL | LUBE FITTING       | GRAISSEUR CONIQUE  | ENGRASADOR CONICO  | SB 8M 3360                         |     |
| 21       | 338 7306 | 1P         | NABE               | HUB                | NOYEU              | CUBO               | 1145-33-01-22<br>8265-SIEHE POS-47 |     |
| 22       | 337 0472 | 2          | DICHTRING          | WASHER             | BAGUE D ETANCHEITE | ANILLO DE JUNTA    | 1155-33-13-20                      | 01  |
| 23       | 337 0470 | 2          | DICHTRING          | WASHER             | BAGUE D ETANCHEITE | ANILLO DE JUNTA    | 1155-33-13-26                      | 01  |
| 24       | 338 7307 | 2          | DICHTRING          | WASHER             | BAGUE D ETANCHEITE | ANILLO DE JUNTA    | 1145-33-01-25                      | 01  |
| 25       | 110 7757 | 2          | KEGELROLLENLAGER   | TAP-ROLLER BEARING | ROULEM A ROUL CON  | COJ-RODIL-CONICOS  | 30207 DIN 720                      | 01  |
| 26       | 110 7755 | 2          | KEGELROLLENLAGER   | TAP-ROLLER BEARING | ROULEM A ROUL CON  | COJ-RODIL-CONICOS  | 30205 DIN 720                      | 01  |
| 27       | 338 6462 | 2          | KAPSEL             | CAPSULE            | CAPSULE            | CAPSULA            | 1055-33-08-32                      | 01  |
| 28       | 110 6472 | 2          | SPLINT             | SPLIT PIN          | GOUPILLE FENDUE    | PASADOR ALETAS     | 5 X 45DIN 74                       |     |

| Bil.<br>Nr. | Teil-Nr. | Stück-<br>Zahl | Deutsch                      | English      | Francais           | Espanol            | Nummer/Bemerkung                                    | ETK |
|-------------|----------|----------------|------------------------------|--------------|--------------------|--------------------|---|-----|
| 21          | 231 4161 | 2              | STOPFEN                      | PLUG         | BOUCHON            | TAPON              | 1145-33-01-38                                       |     |
| 32          | 338 4314 | 6              | BUCHSE                       | BUSH         | DOUILLE            | CASQUILLO          | 1145-33-24-02                                       |     |
| 33          | 338 4321 | 1              | LENKSPURHEBEL                | STEERING ARM | LEV ATTACHE FUSEE  | PALANCA BIELA ACOP | 1145-33-29-01                                       |     |
| 34          | 338 4323 | 1              | LENKHEBEL                    | STEERING ARM | LEVIER DE DIRECTIO | PALANCA DIRECCION  | 1145-33-30-01                                       |     |
| 35          | 338 4333 | 1              | LENKSPURHEBEL                | STEERING ARM | LEV ATTACHE FUSEE  | PALANCA BIELA ACOP | 1145-33-41-01<br>B106-FUER HYDROLENKUNG             |     |
| 36          | 338 4335 | 1              | LENKHEBEL                    | STEERING ARM | LEVIER DE DIRECTIO | PALANCA DIRECCION  | 1145-33-42-01<br>B106-FUER HYDROLENKUNG             |     |
| 42          | 121 5743 | 4              | SECHSKANTMUTTER              | HEX-NUT      | ECROU 6 PANS       | TUERCA HEXAGONAL   | 2 107 J 1<br>B074-ERSATZ FUER POS-7                 |     |
| 43          | 237 6233 | 2              | PASSFEDER                    | KEY          | CLAVETTE ENCASTREE | LENGUETA AJUSTE    |   |     |
| 47          | 238 1381 | 1              | NABE                         | HUB          | NOYEU              | CUBO               | B041-BEI ERSTHALIGEN ERSATZ<br>POS-14-48 HITLIEFERN |     |
| 48          | 238 1373 | 1              | KAPPE<br><i>ohne Gehäuse</i> | CAP          | CAPUCHON/CALOTTE   | SOMBRE- /CAPUCHON  | B233-NUR MIT POS-47 VERWENDEN                       |     |



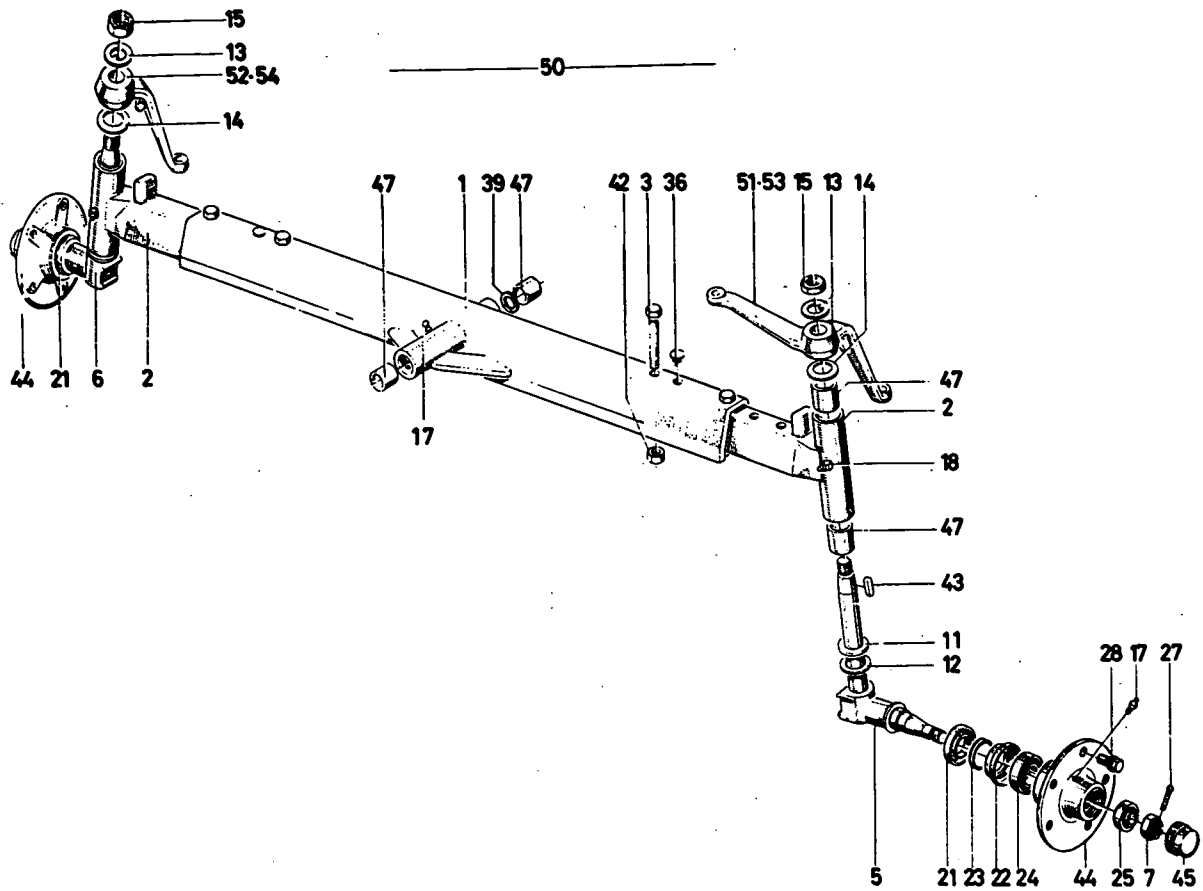

1145-33 501 7149

| Bld. Nr. | Teil-Nr. | Stück-Zahl | Deutsch            | English            | Français           | Español            | Nummer/Bemerkung                     | ETK |
|----------|----------|------------|--------------------|--------------------|--------------------|--------------------|--------------------------------------|-----|
| 1        | 338 9326 | 1          | ACHSBRÜCKE         | AXLE BRACKET       | PONT ESSIEU        | PUNTE EJE          | 1145-33-31-10-8211, MIT POS. 47      |     |
| 2        | 338 9328 | 2          | FAUSTARM           | END PIECE          | BRAS               | PIVOTE DIRECC.     | 1145-33-33-10                        |     |
| 3        | 111 3763 | 4          | SECHSKANTSCHRAUBE  | HEX-BOLT           | VIS 6 PANS         | TORNILLO HEXAGONAL | M16X1,5 X 90 DIN 960-M 8-8           |     |
| 5        | 338 9319 | 1          | LENKSCHENKEL       | STEERING KNUCKLE   | LEV CDE DE LA FUSE | PIVOTE DIRECCION   | 1145-33-27-10 8195, LINKS            |     |
| 6        | 338 9320 | 1          | LENKSCHENKEL       | STEERING KNUCKLE   | LEV CDE DE LA FUSE | PIVOTE DIRECCION   | 1145-33-28-10 8267, RECHTS           |     |
| 7        | 111 3283 | 2          | KRONENMUTTER       | CASTLE NUT         | ECROU-CRENELE      | TUERCA CORONA      | M24X1,5 DIN 937-SS                   |     |
| 10       | 338 9303 | 2          | BRUCKSCHEIBE       | THRUST PLATE       | RONDELLE DE BUTEE  | ARANDELA PRESION   | 1145-33-01-11                        |     |
| 12       | 338 9306 | 2          | SCHEIBE            | DISC/PANE/PLATE    | RONDELLE/DISQUE    | DISCO              | 1145-33-01-14                        |     |
| 13       | 338 8449 | 2          | SICHERUNGSBLECH    | LOCKING PLATE      | TOLE DE SECURITE   | CHAPA SEGURIDAD    | 1135-33-01-23                        |     |
| 14       | 338 8444 | 2          | TELLERFEDER        | CUP SPRING         | RESSORT BELLEVILLE | RESORTE DE PLATO   | 1135-33-01-13                        |     |
| 15       | 111 3206 | 2          | SECHSKANTMUTTER    | HEX-NUT            | ECROU 6 PANS       | TUERCA HEXAGONAL   | M27X1,5 DIN 936-M6S-PHOSPH           |     |
| 17       | 116 8225 | 1          | KEGELSCHMIERNIPPEL | LUBE FITTING       | GRAISSEUR CONIQUE  | ENGRASADOR CONICO  | SA 8H 3360                           |     |
| 18       | 116 8227 | 4          | KEGELSCHMIERNIPPEL | LUBE FITTING       | GRAISSEUR CONIQUE  | ENGRASADOR CONICO  | SB 8H 3360                           |     |
| 21       | 339 0472 | 2          | DICHTRING          | WASHER             | BAGUE D ETANCHEITE | ANILLO DE JUNTA    | 1155-33-13-28                        | 01  |
| 22       | 339 0470 | 2          | DICHTRING          | WASHER             | BAGUE D ETANCHEITE | ANILLO DE JUNTA    | 1155-33-13-26                        | 01  |
| 23       | 338 9309 | 2          | DICHTRING          | WASHER             | BAGUE D ETANCHEITE | ANILLO DE JUNTA    | 1145-33-01-25                        | 01  |
| 24       | 110 9957 | 2          | KEGELROLLENLAGER   | TAP-ROLLER BEARING | ROULEN A ROUL COM  | COJ-RODIL-CONICOS  | 30207 DIN 720                        | 01  |
| 25       | 110 9955 | 2          | KEGELROLLENLAGER   | TAP-ROLLER BEARING | ROULEN A ROUL COM  | COJ-RODIL-CONICOS  | 30205 DIN 720                        | 01  |
| 27       | 110 4467 | 2          | SPLINT             | SPLIT PIN          | GOUPILLE FENDUE    | PASADOR ALETAS     | 5 X 30DIN 94                         |     |
| 28       | 338 7372 | 10         | RADBOLZEN          | PIN                | BOULON DE ROUE     | BULON RUEDA        | 1110-33-01-13                        |     |
| 36       | 231 4169 | 2          | STOPFEN            | PLUG               | BOUCHON            | TAPON              | 1145-33-01-38                        |     |
| 39       | 233 0834 | SZ         | SCHEIBE            | DISC/PANE/PLATE    | RONDELLE/DISQUE    | DISCO              | 8076, EINZELTEILE SIEHE POS. 950-951 |     |
| 42       | 121 5993 | 4          | SECHSKANTMUTTER    | HEX-NUT            | ECROU 6 PANS       | TUERCA HEXAGONAL   | 2 109 J 1                            |     |

| Bilf. Nr. | Teil-Nr. | Stück-Zahl | Deutsch       | English         | Français           | Español            | Nummer/Bemerkung                         | ETK |
|-----------|----------|------------|---------------|-----------------|--------------------|--------------------|--|-----|
| 43        | 237 6233 | 2          | PASSFEDER     | KEY             | CLAVETTE ENCASTREE | LENGUETA AJUSTE    |  |     |
| 44        | 238 1381 | 2          | NABE          | HUB             | MOYEU              | CUBO               |  |     |
| 45        | 238 1373 | 2          | KAPPE         | CAP             | CAPUCHON/CALOTTE   | SOMBRER./CAPUCHON  |  |     |
| 47        | 338 9314 | 6          | BUCHSE        | BUSH            | BOUILLE            | CASQUILLO          | 1145-33-24-02                            |     |
| 50        | 238 1391 | 1          | VORDERACHSE   | FRONT AXLE      | ESSIEU AVANT       | EJE DELANTERO      | 8328, UNGEFEDERT                         |     |
| 51        | 338 9321 | 1          | LENKSPURHEBEL | STEERING ARM    | LEV ATTAQUE FUSEE  | PALANCA BIELA ACOP | 1145-33-29-03                            |     |
| 52        | 338 9323 | 1          | LENKHEBEL     | STEERING ARM    | LEVIER DE DIRECTIO | PALANCA DIRECCION  | 1145-33-30-03                            |     |
| 53        | 338 9333 | 1          | LENKSPURHEBEL | STEERING ARM    | LEV ATTAQUE FUSEE  | PALANCA BIELA ACOP | 1145-33-41-01<br>8106, FUER HYDROLENKUNG |     |
| 54        | 338 9335 | 1          | LENKHEBEL     | STEERING ARM    | LEVIER DE DIRECTIO | PALANCA DIRECCION  | 1145-33-42-01<br>8106, FUER HYDROLENKUNG |     |
| 50        | 233 0836 | NB         | SCHEIBE       | DISC/PANE/PLATE | RONDELLE/DISQUE    | DISCO              | D 1,0 MM                                 |     |
| 51        | 233 0837 | NB         | SCHEIBE       | DISC/PANE/PLATE | RONDELLE/DISQUE    | DISCO              | D 2,0 MM                                 |     |

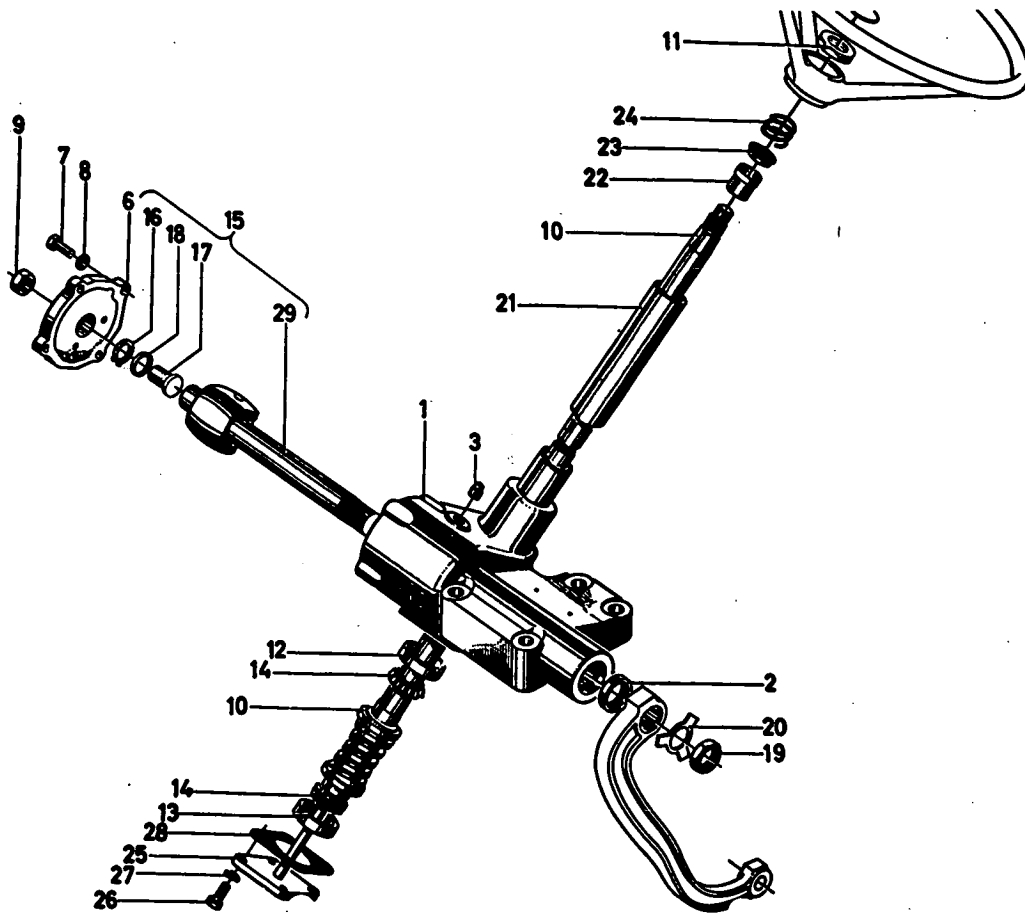

| Bild Nr. | Teile-Nr. | Stück-Zahl | Deutsch            | English            | Français            | Español            | 1145-37 500 4216<br>Nummer/Bemerkung | ETK |
|----------|-----------|------------|--------------------|--------------------|---------------------|--------------------|--------------------------------------|-----|
| 1        | 237 5197  | 1          | GEHÄUSE            | HOUSING/CASE       | CARTER/BOITIER      | CAJA/BLOQUE/CUERPO |                                      |     |
| 2        | 231 0994  | 1          | WELLENDICHRING     | SHAFT SEAL         | JOINT D ARBRE       | ANILLO HERMET-EJE  |                                      | 01  |
| 3        | 338 7435  | 1          | VERSCHLUSSSCHRAUBE | SCREW PLUG         | BOUCHON FILÊTE      | TAPON ROSCADO      | 1110-37-02-29                        |     |
| 6        | 338 8966  | 1          | GEHÄUSEDECKEL      | HOUSING COVER      | COUV DE CARTER      | TAPA CAJA          | 1136-37-02-06                        |     |
| 7        | 231 1721  | 4          | SECHSKANTSCHRAUBE  | HEX-BOLT           | VIS 6 PANS          | TORNILLO HEXAGONAL |                                      |     |
| 8        | 231 0996  | 4          | FEDERSCHEIBE       | SPRING WASHER      | RONDELLE ELASTIQUE  | ARANDELA ELASTICA  |                                      |     |
| 9        | 111 3165  | 1          | SECHSKANTMUTTER    | HEX-NUT            | ECROU 6 PANS        | TUERCA HEXAGONAL   | M14X1.5 DIN 936-M6S                  |     |
| 10       | 231 0789  | 1          | LENKSPINDEL        | STEERING SPINDLE   | ARBRE DE DIRECTION  | MUSILLO DIRECCION  |                                      |     |
| 11       | 111 3184  | 1          | SECHSKANTMUTTER    | HEX-NUT            | ECROU 6 PANS        | TUERCA HEXAGONAL   | M16X1.5 DIN 936-M6S                  |     |
| 12       | 338 8969  | 1          | ROLLENLAUFRING     | ROLLER RACE        | BAGUE D ROLL A RLX  | ARO RODADURA RODIL | 1136-37-02-15                        | 01  |
| 13       | 338 8970  | 1          | RING               | RING               | BAGUE/ANNEAU        | ANILLO             | 1136-37-02-16                        | 01  |
| 14       | 338 8971  | 2          | ROLLENKAEFIG       | ROLLER CAGE        | CAGE A ROULEAUX     | CAJA DE RODILLOS   | 1136-37-02-17                        | 01  |
| 15       | 238 5248  | 1          | LENKROLLENWELLE    | SHAFT              | ARBRE POU LIE-GUIDE | EJE RODIL-DIRECC.  |                                      |     |
| 16       | 338 8973  | 1          | SICHERUNGSRING     | CIRCLIP            | CIRCLIP             | CIRCLIP            | 1136-37-02-19                        |     |
| 17       | 339 1784  | 1          | SCHRAUBE           | SCREW/BOLT         | VIS/BOULON          | TORNILLO           | 1355-37-04-32                        |     |
| 18       | 231 1000  | 1P         | FUEHRUNGSSCHEIBE   | GUIPE PLATE        | PILOTE              | PLATO GUIA         | 8285-SIEME POS-954-959               |     |
| 19       | 111 3195  | 1          | SECHSKANTMUTTER    | HEX-NUT            | ECROU 6 PANS        | TUERCA HEXAGONAL   | M22X1.5 DIN 936-M6S                  |     |
| 20       | 112 3627  | 1          | SICHERUNGSBLECH    | LOCKING PLATE      | TOLE DE SECURITE    | CHAPA SEGURIDAD    | 23 DIN 463-ST                        | 01  |
| 21       | 231 1716  | 1          | MANTELROHR         | JACKET TUBE        | TUBE CHEMISE        | TUBO ENVOLVENTE    |                                      |     |
| 22       | 338 7850  | 1          | LAGERBUCHSE        | BEARING BUSH       | DOUILLE PALIER      | CASQUILLO SOPORTE  | 1125-37-02-33                        | 01  |
| 23       | 338 7406  | 1          | ZENTRIERING        | CENTERING RING     | BAGUE DE CENTRAGE   | ANILLO CENTRAJE    | 1110-37-02-14                        |     |
| 24       | 338 7849  | 1          | DRUCKFEDER         | COMPRESSION SPRING | RESSORT DE COMPR    | RESORTE PRESION    | 1125-37-02-31                        |     |
| 25       | 338 8975  | 1          | FLANSCH            | FLANGE             | BRIDE/COLLET        | BRIDA              | 1136-37-02-29                        |     |
| 26       | 110 3599  | 4          | SECHSKANTSCHRAUBE  | HEX-BOLT           | VIS 6 PANS          | TORNILLO HEXAGONAL | M 8X 20Z3 DIN 933- 8-8-A4C           |     |
| 27       | 231 1006  | 4          | FEDERSCHEIBE       | SPRING WASHER      | RONDEL. E ELASTIQUE | ARANDELA ELASTICA  |                                      |     |

| Bld<br>Nr. | Teil-Nr. | Stück-<br>Zahl | Deutsch         | English         | Français            | Español           | Nummer/Bemerkung           | ETK |
|------------|----------|----------------|-----------------|-----------------|---------------------|-------------------|----------------------------|-----|
| 28         | 231 1007 | 1P             | DICHTUNG        | GASKET          | GARNITURE/JOINT     | JUNTA             | 0265-SIEME P05-950-953     | 01  |
| 29         | 231 0998 | 1              | LENKROLLENWELLE | SHAFT           | ARBRE POU LIE-GUIDE | EJE RODIL-DIRECC- |                            |     |
| 950        | 338 8977 | NB             | DICHTUNG        | GASKET          | GARNITURE/JOINT     | JUNTA             | 1136-37-02-33<br>A 0.1 MM  | 01  |
| 951        | 338 8978 | NB             | DICHTUNG        | GASKET          | GARNITURE/JOINT     | JUNTA             | 1136-37-02-34<br>A 0.12 MM | 01  |
| 952        | 338 8979 | NB             | DICHTUNG        | GASKET          | GARNITURE/JOINT     | JUNTA             | 1136-37-02-35<br>A 0.15 MM | 01  |
| 953        | 338 8980 | NB             | DICHTUNG        | GASKET          | GARNITURE/JOINT     | JUNTA             | 1136-37-02-36<br>A 0.3 MM  | 01  |
| 954        | 231 1229 | NB             | SCHEIBE         | DISC/PANE/PLATE | RONDELLE/DISQUE     | DISCO             | A 2.25 MM                  |     |
| 955        | 231 1230 | NB             | SCHEIBE         | DISC/PANE/PLATE | RONDELLE/DISQUE     | DISCO             | A 2.3 MM                   |     |
| 956        | 231 1231 | NB             | SCHEIBE         | DISC/PANE/PLATE | RONDELLE/DISQUE     | DISCO             | A 2.33 MM                  |     |
| 957        | 231 1232 | NB             | SCHEIBE         | DISC/PANE/PLATE | RONDELLE/DISQUE     | DISCO             | A 2.4 MM                   |     |
| 958        | 231 1233 | NB             | SCHEIBE         | DISC/PANE/PLATE | RONDELLE/DISQUE     | DISCO             | A 2.45 MM                  |     |
| 959        | 231 1234 | NB             | SCHEIBE         | DISC/PANE/PLATE | RONDELLE/DISQUE     | DISCO             | A 2.5 MM                   |     |



MECHANISCHE LENKUNG - ALLRAD  
 MECHANICAL STEERING ASSEMBLY - FOUR WHEEL DRIVE  
 MECANISME DE DIRECTION MECANIQUE (TIMONERIE) - TOUTES ROUES MOTRICES  
 DIRECCION MECANICA - TRACCION EN LAS 4 RUEDAS

1006-37 500 5221

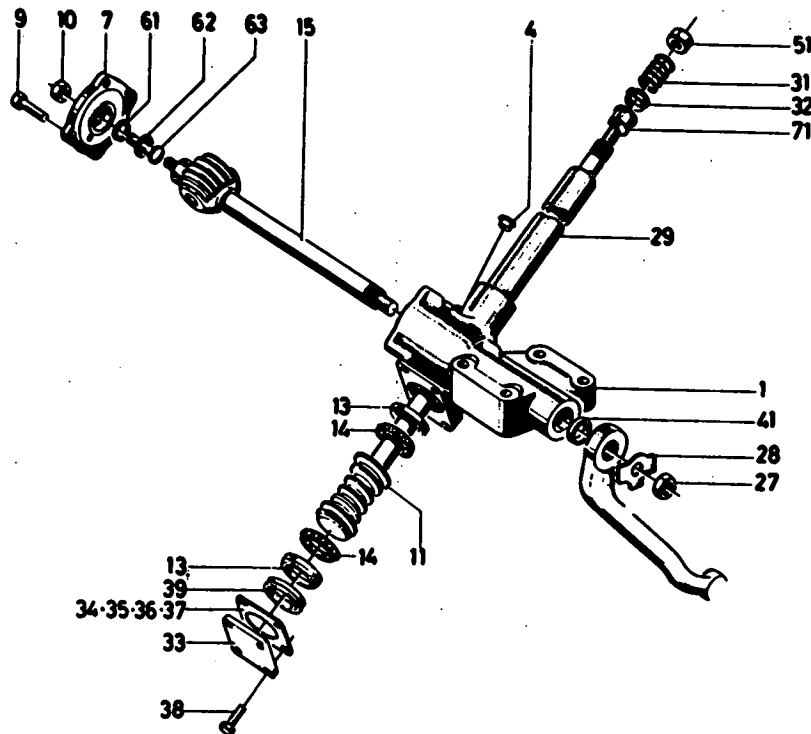

1006-37 500 5221

| Bld Nr. | Teile-Nr. | Stück-Zahl | Deutsch           | English            | Français           | Español            | Nummer/Bemerkung           | ETK |
|---------|-----------|------------|-------------------|--------------------|--------------------|--------------------|----------------------------|-----|
| 1       | 232 4913  | 1          | GEHÄUSE           | HOUSING/CASE       | CARTER/BOITIER     | CAJA/BLOQUE/CUERPO | B211, MIT POS-41           |     |
| 4       | 232 4747  | 1          | STOPFEN           | PLUG               | BOUCHON            | TAPON              |                            |     |
| 7       | 296 2779  | 1          | GEHÄUSEBECKEL     | HOUSING COVER      | COUV DE CARTER     | TAPA CAJA          |                            |     |
| 9       | 110 3598  | 8          | SECHSKANTSCHRAUBE | HEX-BOLT           | VIS 6 PANS         | TORNILLO HEXAGONAL | M 8X 25Z3 DIN 933- 8.8-A4C |     |
| 10      | 111 3165  | 1          | SECHSKANTMUTTER   | HEX-NUT            | ECROU 6 PANS       | TUERCA HEXAGONAL   | M14X1,5 DIN 934-M6S        |     |
| 11      | 233 5869  | 1          | LENKSPINDEL       | STEERING SPINDLE   | ARBRE DE DIRECTION | MUSILLO DIRECCION  | B211, MIT POS-51           |     |
| 13      | 339 1356  | 2          | LAUFRING          | RACE/RING          | BAGUE A BILLES     | ANILLO RODADURA    | 1335-37-08-15              | 01  |
| 14      | 232 4654  | 2          | KUGELHALTER       | BALL RETAINER      | PORTE-BOULE        | PORTA-BOLA         |                            | 01  |
| 15      | 233 5861  | 1          | LENKROLLENWELLE   | SHAFT              | ARBRE POULIE-GUIDE | EJE RODIL-DIRECC.  | B211, MIT POS-61-63        |     |
| 27      | 111 3213  | 1          | SECHSKANTMUTTER   | HEX-NUT            | ECROU 6 PANS       | TUERCA HEXAGONAL   | M30X1,5 DIN 934-M6S        |     |
| 28      | 232 4660  | 1          | SICHERUNGSBLECH   | LOCKING PLATE      | TOLE DE SECURITE   | CHAPA SEGURIDAD    |                            | 01  |
| 29      | 233 5921  | 1          | MANTELROHR        | JACKET TUBE        | TUBE CHERISE       | TUBO ENVOLVENTE    | B211, MIT POS-71           |     |
| 31      | 338 7899  | 1          | DRUCKFEDER        | COMPRESSION SPRING | RESSORT DE COMPR   | RESORTE PRESION    | 1125-37-02-31              |     |
| 32      | 338 7406  | 1          | ZENTRIERRING      | CENTERING RING     | BAGUE DE CENTRAGE  | ANILLO CENTRAJE    | 1110-37-02-14              |     |
| 33      | 232 4912  | 1          | FLANSCH           | FLANGE             | BRIDE/COLLET       | BRIDA              |                            |     |
| 34      | 339 1788  | 1          | DICHTUNG          | GASKET             | GARNITURE/JOINT    | JUNTA              | 1335-37-04-43<br>A 0,15 MM | 01  |
| 35      | 339 1789  | 1          | DICHTUNG          | GASKET             | GARNITURE/JOINT    | JUNTA              | 1335-37-04-44<br>A 0,12 MM | 01  |
| 36      | 339 1790  | 1          | DICHTUNG          | GASKET             | GARNITURE/JOINT    | JUNTA              | 1335-37-04-45<br>A 0,15 MM | 01  |
| 37      | 339 1791  | 1          | DICHTUNG          | GASKET             | GARNITURE/JOINT    | JUNTA              | 1335-37-04-46<br>A 0,3 MM  | 01  |
| 38      | 111 2333  | 4          | SECHSKANTSCHRAUBE | HEX-BOLT           | VIS 6 PANS         | TORNILLO HEXAGONAL | M 8X 25 DIN 933- 8.8-A4C   |     |
| 39      | 232 4691  | 1          | ZWISCHENRING      | INTERMEDIATE RING  | BAGUE INTERMED.    | ANILLO INTERMEDIO  |                            |     |
| 41      | 232 4658  | 1          | WELLENDICHTRING   | SHAFT SEAL         | JOINT D ARBRE      | ANILLO HERMET-EJE  |                            | 01  |

| Bad Nr. | Teil-Nr. | Stück-Zahl | Deutsch         | English         | Français        | Español          | Nummer/Bemerkung        | ETK |
|---------|----------|------------|-----------------|-----------------|-----------------|------------------|-------------------------|-----|
| 51      | 111 3183 | 1          | SECHSKANTMUTTER | HEX-NUT         | ECROU 6 PANS    | TUERCA HEXAGONAL | M16X1,5 DIN 934-MSS-A4C |     |
| 61      | 338 8973 | 1          | SICHERUNGSRING  | CIRCLIP         | CIRCLIP         | CIRCLIP          | 1136-37-02-19           |     |
| 62      | 231 1000 | IP         | SCHEIBE         | DISC/PANE/PLATE | RONDELLE/DISQUE | DISCO            | B285.SIEHE POS-950-955  |     |
| 63      | 232 4657 | 1          | SCHRAUBE        | SCREW/BOLT      | VIS/BOULON      | TORNILLO         |                         |     |
| 71      | 232 4662 | 1          | BUECHSE         | BUSH            | BOITE           | CASQUILLO        |                         | 01  |
| 750     | 231 1229 | NB         | SCHEIBE         | DISC/PANE/PLATE | RONDELLE/DISQUE | DISCO            | A 2.25 MM               |     |
| 751     | 231 1230 | NB         | SCHEIBE         | DISC/PANE/PLATE | RONDELLE/DISQUE | DISCO            | A 2.3 MM                |     |
| 752     | 231 1231 | NB         | SCHEIBE         | DISC/PANE/PLATE | RONDELLE/DISQUE | DISCO            | A 2.35 MM               |     |
| 753     | 231 1232 | NB         | SCHEIBE         | DISC/PANE/PLATE | RONDELLE/DISQUE | DISCO            | A 2.4 MM                |     |
| 754     | 231 1233 | NB         | SCHEIBE         | DISC/PANE/PLATE | RONDELLE/DISQUE | DISCO            | A 2.45 MM               |     |
| 755     | 231 1234 | NB         | SCHEIBE         | DISC/PANE/PLATE | RONDELLE/DISQUE | DISCO            | A 2.5 MM                |     |

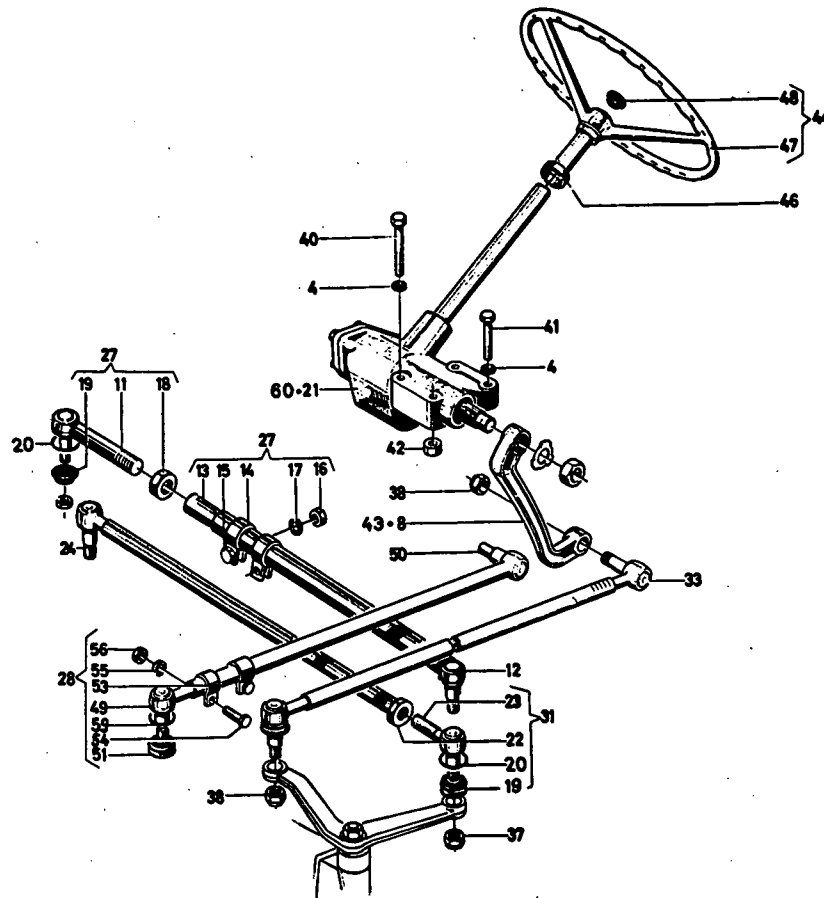

1145-37 500 4215

| Bld Nr. | Teil-Nr. | Stück-Zahl | Deutsch           | English           | Français           | Español            | Nummer/Bemerkung                                | ETK |
|---------|----------|------------|-------------------|-------------------|--------------------|--------------------|---|-----|
| 4       | 116 96%  | 4          | SICHERUNGSSCHEIBE | LOCKING WASHER    | RONDELLE SECURITE  | ARANDELA SEGURIDAD | 14 H 2203                                       |     |
| 8       | 237 3460 | IP         | LENKSTOCKHEBEL    | DROP ARM          | LEVIER CDE DIRECT  | PALNCA-EL00-DIREC. | 1145-37-01-08<br>8285-SIEME P05-43              |     |
| 11      | 238 1195 | 1          | KUGELGELENK       | BALL JOINT        | JOINT A ROTULE     | ARTICULAC-ESFERIC  |   |     |
| 12      | 238 1197 | 1          | KUGELGELENK       | BALL JOINT        | JOINT A ROTULE     | ARTICULAC-ESFERIC  |   |     |
| 13      | 233 4603 | 1          | VERSTELLSTANGE    | ADJUSTING ROD     | TRINGLE DE REGLAGE | BARRA GRADUAC.     |   |     |
| 14      | 233 4604 | 2          | KLEMMSCHELLE      | CLIP              | COLLIER DE SERRAGE | ABRAZADERA APRIETO |   |     |
| 15      | 111 1298 | 1          | SECHSKANTSCHRAUBE | HEX-BOLT          | VIS 6 PANS         | TORNILLO HEXAGONAL | M10X 45 DIN 931-M 8-A A4C                       |     |
| 16      | 110 2659 | 1          | SECHSKANTMUTTER   | HEX-NUT           | ECROU 6 PANS       | TUERCA HEXAGONAL   | M10 DIN 934-M 2 A4C                             |     |
| 17      | 110 2600 | 1          | FEDERRING         | SPRING LOCKWASHER | RONDELLE GROMER    | ARANDELA ELASTICA  | A 30 DIN 128 A4C                                |     |
| 18      | 111 3179 | 1          | SECHSKANTMUTTER   | HEX-NUT           | ECROU 6 PANS       | TUERCA HEXAGONAL   | M16X1,5 DIN 936-M65 V2KC                        |     |
| 19      | 233 4605 | 2          | KAPPE             | CAP               | CAPUCHON/CALOTTE   | SOMBRETT-/CAPUCHON |   | 01  |
| 20      | 233 5203 | 2          | SICHERUNGSRING    | CIRCLIP           | CIRCLIP            | CIRCLIP            |   |     |
| 21      | 230 1158 | IP         | LENKSTOCK         | COLUMN ASSY.      | COMMANDE DIRECTION | BLOQUE DIRECTION   | 9313-TEILENUMMERN-LISTENBLAT<br>1145-37 5004215 |     |
| 22      | 111 3179 | 1          | SECHSKANTMUTTER   | HEX-NUT           | ECROU 6 PANS       | TUERCA HEXAGONAL   | M16X1,5 DIN 936-M65 V2KC                        |     |
| 23      | 238 1195 | 1          | KUGELGELENK       | BALL JOINT        | JOINT A ROTULE     | ARTICULAC-ESFERIC  |   |     |
| 24      | 238 1196 | 1          | KUGELGELENK       | BALL JOINT        | JOINT A ROTULE     | ARTICULAC-ESFERIC  |   |     |
| 27      | 238 2761 | 1          | LENKSPURSTANGE    | TRACK ROD         | BARRE D ACCOUPLEM  | BIELA ACOPL-RODAD  | TELESKOP  |     |
| 28      | 238 2779 | 1          | LENKSTANGE        | DRAG LINK         | BIELLE DE DIRECTIO | BARRA DIRECCION    | TELESKOP  |     |
| 31      | 238 2758 | 1          | LENKSPURSTANGE    | TRACK ROD         | BARRE D ACCOUPLEM  | BIELA ACOPL-RODAD  | B226-NORMAL                                     |     |
| 33      | 238 2777 | 1          | LENKSTANGE        | DRAG LINK         | BIELLE DE DIRECTIO | BARRA DIRECCION    | B226-NORMAL                                     |     |
| 37      | 116 1629 | 2          | MUTTER            | NUT               | ECROU              | TUERCA             | M10X1 H 2132- 2                                 |     |
| 38      | 116 1630 | 2          | MUTTER            | NUT               | ECROU              | TUERCA             | M12X1,5H 2132- 2                                |     |

| Bil. Nr. | Teil-Nr. | Stück-Zahl | Deutsch           | English           | Français           | Español            | Nummer/Bemerkung                                 | ETK |
|----------|----------|------------|-------------------|-------------------|--------------------|--------------------|--|-----|
| 40       | 110 1948 | 2          | SECHSKANTSCHRAUBE | HEX-BOLT          | VIS 6 PANS         | TORNILLO HEXAGONAL | M14X 70 DIN 933-M 8-8 V2KC                       |     |
| 41       | 112 2458 | 2          | SECHSKANTSCHRAUBE | HEX-BOLT          | VIS 6 PANS         | TORNILLO HEXAGONAL | M14X 55 DIN 933-M 8-8 A4C                        |     |
| 42       | 230 1516 | 2          | MUELSE            | SLEEVE            | DOUILLE            | CASQUILLO          |  |     |
| 43       | 237 3460 | 1          | LENKSTOCKHEBEL    | DROP ARM          | LEVIER CDE DIRECT  | PALNCA-EL08-DIREC. |  |     |
| 44       | 232 1955 | 1          | LENKRAD           | STEERING WHEEL    | VOLANT DIRECTION   | VOLANTE DIRECCION  |  |     |
| 46       | 230 8077 | 1          | GUMMITELLE        | RUBBER GROMMET    | GAINE CAOUTCHOUC   | FUNDA CAUCHO       |  |     |
| 47       | 232 1992 | 1          | LENKRAD           | STEERING WHEEL    | VOLANT DIRECTION   | VOLANTE DIRECCION  |  |     |
| 48       | 338 7869 | 1          | ABDECKKAPPE       | CAP               | CAPUCHON PROTECT   | CAPUCHON RECUBRIM. | 1125-37-05-05                                    |     |
| 49       | 238 1201 | 1          | GELENK            | JOINT/HINGE       | JOINT/ARTICULATION | ARTICULAC.         |  |     |
| 50       | 238 1193 | 1          | GELENK            | JOINT/HINGE       | JOINT/ARTICULATION | ARTICULAC.         |  |     |
| 51       | 233 5927 | 2          | DICHTBALG         | SEALING BELLOWS   | JOINT A SOUFFLET   | FUELLE HERMETIZ.   |  | 01  |
| 53       | 237 2997 | 2          | KLEMMSCHELLE      | CLIP              | COLLIER DE SERRAGE | ABRAZADERA APRIETO |  |     |
| 54       | 111 1195 | 2          | SECHSKANTSCHRAUBE | HEX-BOLT          | VIS 6 PANS         | TORNILLO HEXAGONAL | M 8X 40 DIN 931- 8-8-A4C                         |     |
| 55       | 110 2799 | 2          | FEDERRING         | SPRING LOCKWASHER | RONDELLE GROWER    | ARANDELA ELASTICA  | A 8 DIN 128 A4C                                  |     |
| 56       | 111 2824 | 2          | SECHSKANTMUTTER   | HEX.NUT           | ECROU 6 PANS       | TUERCA HEXAGONAL   | M 8 DIN 934-M 2 A4C                              |     |
| 59       | 233 8751 | 2          | SICHERUNGSRING    | CIRCLIP           | CIRCLIP            | CIRCLIP            |  |     |
| 60       | 237 4346 | TN         | LENKSTOCK         | COLUMN ASSY.      | COMMANDE DIRECTION | BLOQUE DIRECCION   | B313-TEILENUMMERN-LISTENBLAT<br>1145-37 500 4216 |     |





LENKGESTÄNGE FÜR MECH. LENKUNG -ALLRAD  
 MECHANICAL STEERING LINKAGE -FOR ALL-WHEEL-DRIVE TRACTOR  
 MECANISME DE DIRECTION MECANIQUE-TOUTES ROUES MOTRICES  
 VARILLAJE PARA DIRECCION MECANICA-VERSION CON TRACCION UNIVERSAL 1003-37 500 6399

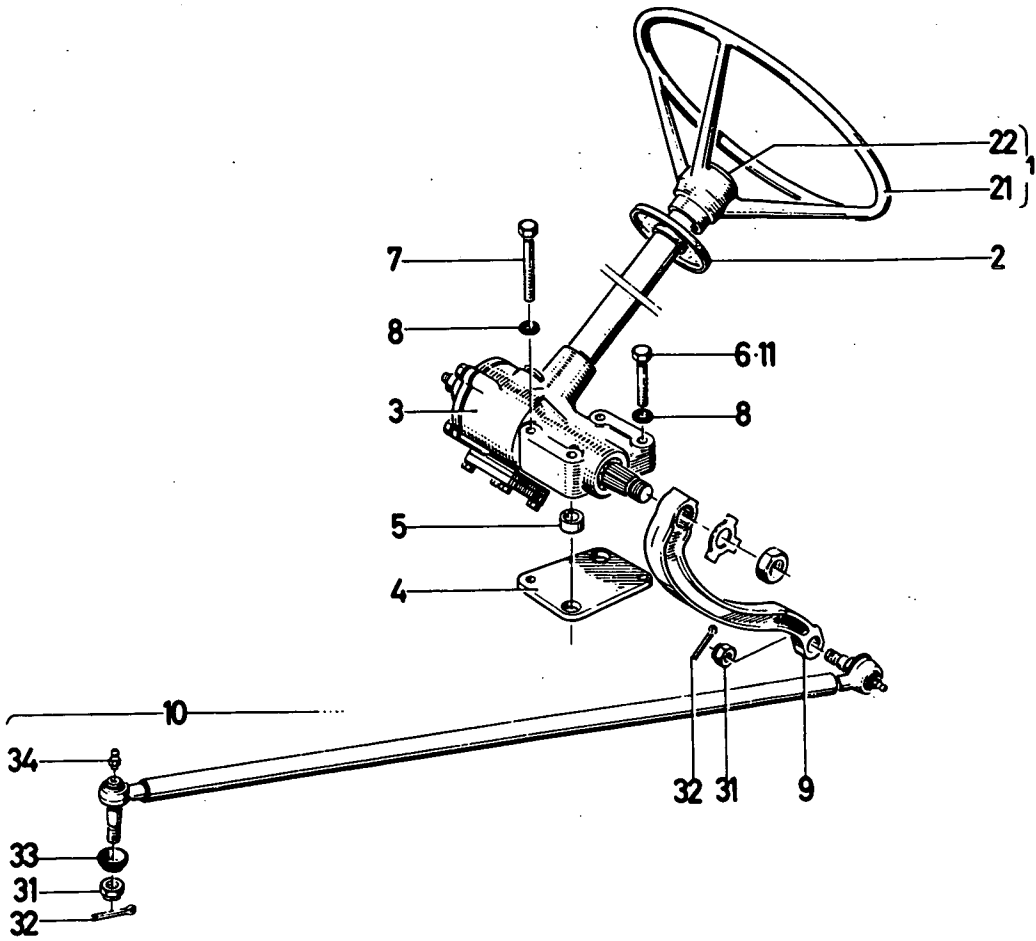

1003-37 500 6399

| Bld. Nr. | Teil-Nr. | Stück-Zahl | Deutsch           | English         | Français           | Español            | Nummer/Bemerkung                                  | ETK |
|----------|----------|------------|-------------------|-----------------|--------------------|--------------------|---|-----|
| 1        | 232 1955 | 1          | LENKRAD           | STEERING WHEEL  | VOLANT DIRECTION   | VOLANTE DIRECCION  |   |     |
| 2        | 233 2986 | 1          | TUELLE            | GRONNET         | DOUILLE            | FUNDA              |   | 01  |
| 3        | 232 0830 | TN         | GEMMER-LENKUNG    | GEMMER STEERING | DIRECTION GEMMER   | DIRECCION GEMMER   | 8313-TEILENUMMERN-LISTENBLATT<br>1006-37 500 5221 |     |
| 4        | 237 6769 | 1          | LENKSTOCKHEBEL    | DROP ARM        | LEVIER CDE DIRECT  | PALNCA-EL00-DIREC. |   |     |
| 5        | 232 0840 | 2          | MUELSE            | SLEEVE          | DOUILLE            | CASQUILLO          |   |     |
| 6        | 111-1707 | 2          | SECHSKANTSCHRAUBE | HEX-BOLT        | VIS 6 PANS         | TORNILLO HEXAGONAL | M14X 65 DIN 931-M 8-8 A4C                         |     |
| 7        | 112 4823 | 2          | SECHSKANTSCHRAUBE | HEX-BOLT        | VIS 6 PANS         | TORNILLO HEXAGONAL | M14X 85 DIN 931-M 8-8 A4C                         |     |
| 8        | 116 7676 | 4          | SICHERUNGSSCHEIBE | LOCKING WASHER  | RONDELLE SECURITE  | ARANDELA SEGURIDAD | 14 H 2203   |     |
| 9        | 237 6769 | 1          | LENKSTOCKHEBEL    | DROP ARM        | LEVIER CDE DIRECT  | PALNCA-EL00-DIREC. |   |     |
| 10       | 231 5361 | TN         | LENKSTANGE        | DRAG LINK       | BIELLE DE DIRECTIO | BARRA DIRECCION    | 8313-TEILENUMMERN-LISTENBLATT<br>1145-37 500 5420 |     |
| 11       | 110 1016 |            | SECHSKANTSCHRAUBE | HEX-BOLT        | VIS 6 PANS         | TORNILLO HEXAGONAL | M14X 80 DIN 931-M 8-8 A4C                         |     |
| 21       | 232 1992 | 1          | LENKRAD           | STEERING WHEEL  | VOLANT DIRECTION   | VOLANTE DIRECCION  |   |     |
| 22       | 338 7869 | 1          | ABDECKKAPPE       | CAP             | CAPUCHON PROTECT   | CAPUCHON RECUBRIM. | 1125-37-05-05                                     |     |
| 31       | 111 3255 | 2          | KRÖNENPUTTER      | CASTLE NUT      | ECROU CRENELE      | TUERCA CORONA      | M14X1,5 DIN 937-65                                |     |
| 32       | 110 6437 | 2          | SPLINT            | SPLIT PIN       | GOUPILE FENDUE     | PASADOR ALETAS     | 3 X 28DIN 94                                      |     |
| 33       | 233 8763 | 2          | KAPPE             | CAP             | CAPUCHON/CALOTTE   | SOMBRER-/CAPUCHON  |   | 01  |
| 34       | 116 8225 | 2          | BRUCKSCHMIERKOPF  | LUBE FITTING    | GRAISSEUR A PRESS  | ENGRASADOR A PRES. | SA 8H 3360  |     |

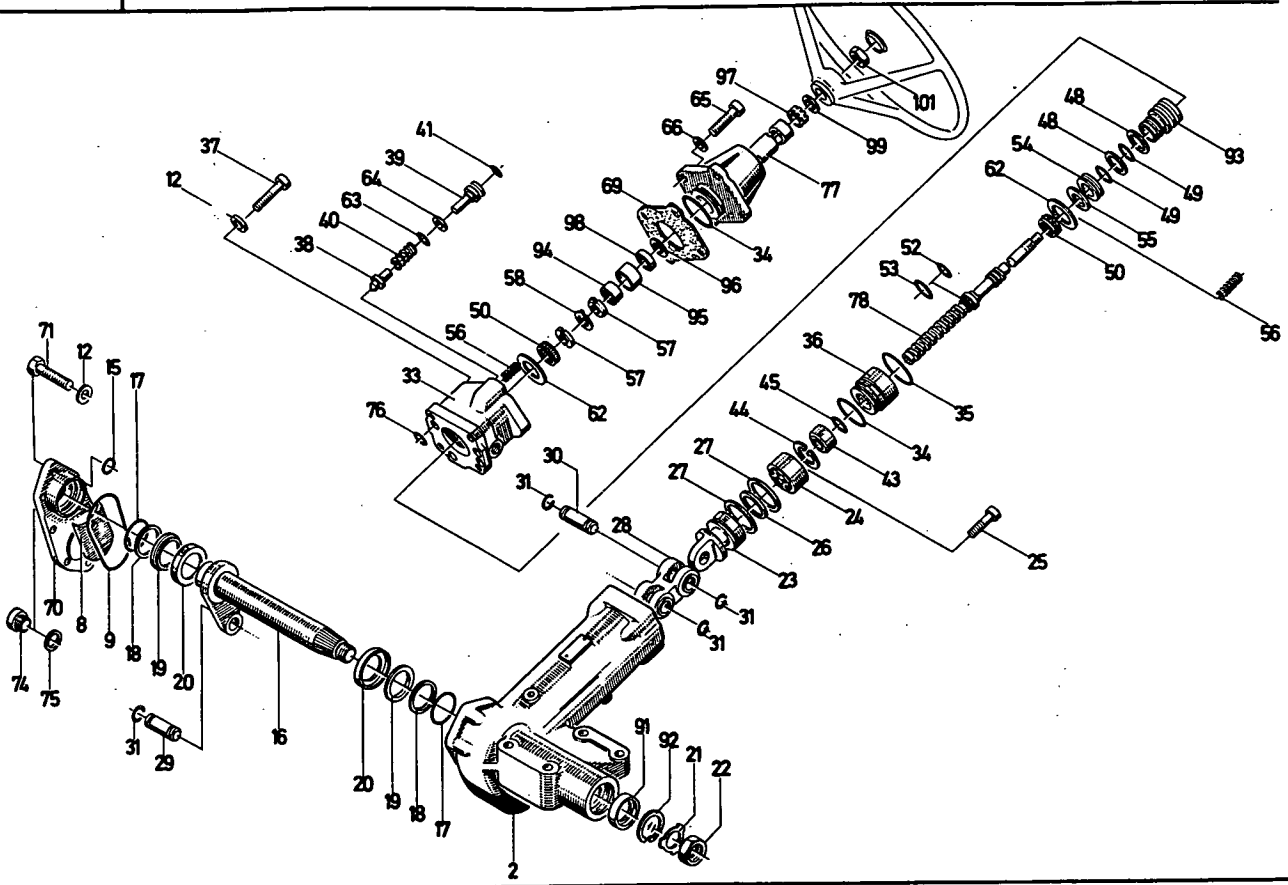

1006-37 500 5385

| Bld. Nr. | Teil-Nr. | Stück-Zahl | Deutsch          | English           | Français           | Español            | Nummer/Bemerkung                | ETK |
|----------|----------|------------|------------------|-------------------|--------------------|--------------------|---------------------------------|-----|
| 2        | 230 9793 | 1          | GEHÄUSE          | HOUSING/CASE      | CARTER/BOITIER     | CAJA/BLOQUE/CUERPO | 8347-VOLLSTÄNDIG MIT POS. 91-92 |     |
| 8        | 231 5137 | 1          | PLATTE           | PLATE             | PLAQUE             | PLACA              | 1145-37-40-08                   |     |
| 9        | 231 5140 | 1          | O-RING           | O-SEAL            | BAGUE TORIQUE      | ANILLO O           | 1145-37-40-09                   | 01  |
| 12       | 231 5142 | 12         | SCHEIBE          | DISC/PANE/PLATE   | RONDELLE/DISQUE    | DISCO              | 1145-37-40-17                   |     |
| 15       | 231 5143 | 15         | O-RING           | O-SEAL            | BAGUE TORIQUE      | ANILLO O           | 1145-37-40-22                   | 01  |
| 16       | 230 9776 | 16         | LENKWELLE        | STEERING SHAFT    | ARBRE DE DIRECTION | EJE DIRECCION      |                                 |     |
| 17       | 231 5144 | 2          | O-RING           | O-SEAL            | BAGUE TORIQUE      | ANILLO O           | 1145-37-40-76                   | 01  |
| 18       | 231 5145 | 2          | STÜTZRING        | SUPPORT RING      | BAGUE DE SUPPORT   | ANILLO APOYO       | 1145-37-40-11                   |     |
| 19       | 231 5146 | 2          | ZENTRIERRING     | CENTERING RING    | BAGUE DE CENTRAGE  | ANILLO CENTRAJE    | 1145-37-40-12                   |     |
| 20       | 231 5147 | 2          | ANLAUFSCHLEIBE   | STOP WASHER       | DISQUE BUTEE       | ARANDELA TOPE      | 1145-37-40-13                   |     |
| 21       | 231 5148 | 1          | SICHERUNGSBLECH  | LOCKING PLATE     | TOLE DE SECURITE   | CHAPA SEGURIDAD    |                                 | 01  |
| 22       | 111 3238 | 1          | SECHSKANTMUTTER  | HEX. NUT          | ECROU 6 PANS       | TUERCA HEXAGONAL   | M35X1,5 DIN 936-M35-ANC         |     |
| 23       | 231 5149 | 1          | KOLBEN           | PISTON/PLUNGER    | PISTON             | EMBOLO/PISTON      | 1145-37-40-27                   |     |
| 24       | 230 9777 | 1          | LENKMUTTER       | STEERING NUT      | ECROU DE DIRECTION | TUERCA DIRECCION   |                                 |     |
| 25       | 112 3701 | 6          | ZYLINDERSCHRAUBE | CHEESE-HEAD SCREW | VIS TETE CYLINDR.  | TORN-COZA-CILINDR. | M 8X 40DIN 912- 8-8 ANC         |     |
| 26       | 231 5150 | 1          | DICHTRING        | WASHER            | BAGUE D ETANCHEITE | ANILLO DE JUNTA    | 1145-37-40-29                   | 01  |
| 27       | 231 5151 | 2          | ABSTREIFRING     | SCRAPER RING      | SEGMENT RACLEUR    | ARO RASPADOR       | 1145-37-40-28                   | 01  |
| 28       | 231 5152 | 1          | PLEUEL           | CONNECTING ROD    | BIELLE             | BIELA              | 1145-37-40-26                   |     |
| 29       | 231 5153 | 1          | LAGERBOLZEN      | PIVOT PIN         | AXE SUPPORT        | BULON SOPORTE      | 1145-37-40-24                   |     |
| 30       | 231 5154 | 1          | LAGERBOLZEN      | PIVOT PIN         | AXE SUPPORT        | BULON SOPORTE      | 1145-37-40-25                   |     |
| 31       | 231 5155 | 4          | SPRENGRING       | SNAP RING         | AGRAFE CIRCULAIRE  | ANILLO RETENCION   | 1145-37-40-23                   | 01  |
| 33       | 231 1251 | 1          | VENTILGEHÄUSE    | VALVE HOUSING     | CORPS DE SOUPEPE   | CAJA VALVULA       | 8347-VOLLSTÄNDIG MIT POS. 93    |     |
| 34       | 231 5157 | 2          | O-RING           | O-SEAL            | BAGUE TORIQUE      | ANILLO O           | 1145-37-40-66                   | 01  |
| 35       | 230 9779 | 1          | O-RING           | O-SEAL            | BAGUE TORIQUE      | ANILLO O           |                                 | 01  |

| Bld Nr. | Teil-Nr. | Stück-Zahl | Deutsch            | English            | Français           | Español            | Nummer/Bemerkung  | ETK |
|---------|----------|------------|--------------------|--------------------|--------------------|--------------------|---|-----|
| 36      | 231 5158 | 1          | ZENTRIERRING       | CENTERING RING     | BAGUE DE CENTRAGE  | ANILLO CENTRAJE    | 1145-37-40-55   |     |
| 37      | 112 2362 | 4          | ZYLINDERSCHRAUBE   | CHEESE-HEAD SCREW  | VIS TETE CYLINDR.  | TORN-BOZA-CILIND.  | M10X 55DIN 912-10-9-A4C                                 |     |
| 38      | 231 5159 | 1          | VENTILSTIFT        | VALVE PIN          | POINTEAU           | PERNO DE VALVULA   | 1145-37-40-62   |     |
| 39      | 231 5160 | 1          | VENTILFUEHRUNG     | VALVE GUIDE        | GUIDE DE SOUPAPE   | GUIA DE VALVULA    | 1145-37-40-64   |     |
| 40      | 231 5161 | 1          | VENTILFEDER        | VALVE SPRING       | RESSORT DE SOUPAPE | RESORTE VALVULA    | 1145-37-40-63   |     |
| 41      | 231 5162 | 1          | O-RING             | O-SEAL             | BAGUE TORIQUE      | ANILLO O           | 1145-37-40-57   | 01  |
| 43      | 230 9780 | 1          | HALTERING          | RETAINING RING     | BAGUE SUPPORT      | ANILLO SUJECCION   |   |     |
| 44      | 110 7827 | 1          | SICHERUNGSRING     | CIRCLIP            | CIRCLIP            | CIRCLIP            | 40X1,75DIN 472  |     |
| 45      | 230 9781 | 1          | O-RING             | O-SEAL             | BAGUE TORIQUE      | ANILLO O           |   | 01  |
| 48      | 231 5164 | 2          | DICHTRING          | WASHER             | BAGUE D ETANCHEITE | ANILLO DE JUNTA    | 1145-37-40-42   | 01  |
| 49      | 231 5165 | 2          | O-RING             | O-SEAL             | BAGUE TORIQUE      | ANILLO O           | 1145-37-40-41   | 01  |
| 50      | 110 9888 | 2          | WILLENKUGELLAGER   | BALL BEARING       | ROUL RAINURE BILLE | COJ-BOLAS FIJO     | 51106 DIN 711   | 01  |
| 52      | 230 9783 | 1          | O-RING             | O-SEAL             | BAGUE TORIQUE      | ANILLO O           |   | 01  |
| 53      | 230 9784 | 1          | DICHTRING          | WASHER             | BAGUE D ETANCHEITE | ANILLO DE JUNTA    |   | 01  |
| 54      | 230 9785 | 1          | DRUCKRING          | THRUST RING        | BAGUE DE BUTEE     | ANILLO PRESSION    |   |     |
| 55      | 230 9786 | 1          | DICHTRING          | WASHER             | BAGUE D ETANCHEITE | ANILLO DE JUNTA    |   | 01  |
| 56      | 231 4603 | 20         | DRUCKFEDER         | COMPRESSION SPRING | RESSORT DE COMPR   | RESORTE PRESSION   |   | 01  |
| 57      | 231 5168 | 2          | WUTMUTTER          | GROOVED NUT        | ECROU RAINURE      | TUERCA RAMURADA    | 1145-37-40-48   |     |
| 58      | 112 4659 | 1          | SICHERUNGSBLECH    | LOCKING PLATE      | TOLE DE SECURITE   | CHAPA SEGURIDAD    | 25DIN 462   |     |
| 62      | 231 1262 | 2          | SCHEIBE            | DISC/PANE/PLATE    | RONDELLE/DISQUE    | DISCO              |   |     |
| 63      | 231 8140 | 1          | O-RING             | O-SEAL             | BAGUE TORIQUE      | ANILLO O           | 1145-37-40-56   | 01  |
| 64      | 231 5175 | SZ         | EINSTELLSCHEIBE    | WASHER/SHIM        | DISQUE DE REGLAGE  | ARANDELA GRADUAC.  | 1154-37-43-10<br>8076-EINZELTEILE SIEHE POS.<br>950-952 |     |
| 65      | 111 0577 | 4          | ZYLINDERSCHRAUBE   | CHEESE-HEAD SCREW  | VIS TETE CYLINDR.  | TORN-BOZA-CILIND.  | M 8X 25DIN 912- 8-8 A4C                                 |     |
| 66      | 231 5174 | 4          | SCHEIBE            | DISC/PANE/PLATE    | RONDELLE/DISQUE    | DISCO              | 1145-37-40-73   |     |
| 69      | 231 5176 | 1          | AUSGLEICHSCHEIBE   | SHIM               | CALE               | ARANDELA COMPENS.  | 1145-37-42-10   |     |
| 70      | 230 9746 | 1          | GEHAEUSEDECKEL     | HOUSING COVER      | COUV DE CARTER     | TAPA CAJA          |   |     |
| 71      | 112 2447 | 7          | SECHSKANTSCHRAUBE  | HEX-BOLT           | VIS 6 PANS         | TORNILLO HEXAGONAL | M10X 30 DIN 933-10-9-A4C                                |     |
| 74      | 111 0422 | 1          | VERSCHLUSSSCHRAUBE | SCREW PLUG         | BOUCHON FILETE     | TAPON ROSCADO      | M12X1,5 DIN 908   |     |
| 75      | 121 3282 | 1          | DICHTRING          | WASHER             | BAGUE D ETANCHEITE | ANILLO DE JUNTA    | 2 905 L 6 IN KLAMMER                                    | 01  |
| 76      | 233 4614 | 4          | O-RING             | O-SEAL             | BAGUE TORIQUE      | ANILLO O           |   | 01  |
| 77      | 233 4614 | 1          | MANTELROHR         | JACKET TUBE        | TUBE CHERISE       | TUBO ENVOLVENTE    | 8347-VOLLSTAENDIG MIT POS.<br>74-77                     |     |
| 78      | 233 5209 | 1          | LENKSPINDEL        | STEERING SPINDLE   | ARBRE DE DIRECTION | HUSILLO DIRECCION  | 8211-MIT POS.101  |     |
| 91      | 339 0829 | 1          | WELLENDICHTRING    | SHAFT SEAL         | JOINT D ARBRE      | ANILLO HERMET-EJE  | 1171-37-21-05   | 01  |
| 92      | 110 7841 | 1          | SICHERUNGSRING     | CIRCLIP            | CIRCLIP            | CIRCLIP            | 56X2 DIN 472  |     |
| 93      | 231 5156 | 1          | VENTILGEHAEUSE     | VALVE HOUSING      | CORPS DE SOUPAPE   | CAJA VALVULA       | 1145-37-40-46   |     |
| 94      | 231 5169 | 1          | NADELHUELSE        | NEEDLE SLEEVE      | DOUILLE AIGUILLES  | CASO AGUJA         | 1145-37-40-67   | 01  |
| 95      | 231 5170 | 1          | LAGERRING          | BEARING RACE       | BAGUE DE PALIER    | ANILO COJINETE     | 1145-37-40-68   | 01  |
| 96      | 231 5172 | 1          | SCHEIBE            | DISC/PANE/PLATE    | RONDELLE/DISQUE    | DISCO              | 1145-37-40-71   |     |
| 97      | 231 5173 | 1          | PENDELLAGERRING    | BEARING RACE       | BAGUE ROUL ARTIC   | ARO COJ-A ROTULA   | 1145-37-40-75   | 01  |
| 98      | 233 4616 | 1          | WELLENDICHTUNG     | SHAFT SEAL         | JOINT D ARBRE      | HERMETIZ-EJE       |   | 01  |
| 99      | 233 4617 | 1          | SCHEIBE            | DISC/PANE/PLATE    | RONDELLE/DISQUE    | DISCO              |   |     |
| 100     | 111 3185 | 1          | SECHSKANTMUTTER    | HEX-NUT            | ECROU 6 PANS       | TUERCA HEXAGONAL   | M16X1,5 DIN 936-M65-PHOSPH                              |     |
| 950     | 230 9790 | NB         | EINSTELLSCHEIBE    | WASHER/SHIM        | DISQUE DE REGLAGE  | ARANDELA GRADUAC.  | A 0,1 MM.   |     |
| 951     | 230 9791 | NB         | EINSTELLSCHEIBE    | WASHER/SHIM        | DISQUE DE REGLAGE  | ARANDELA GRADUAC.  | A 0,15 MM.  |     |
| 952     | 230 9792 | NB         | EINSTELLSCHEIBE    | WASHER/SHIM        | DISQUE DE REGLAGE  | ARANDELA GRADUAC.  | A 0,30 MM   |     |

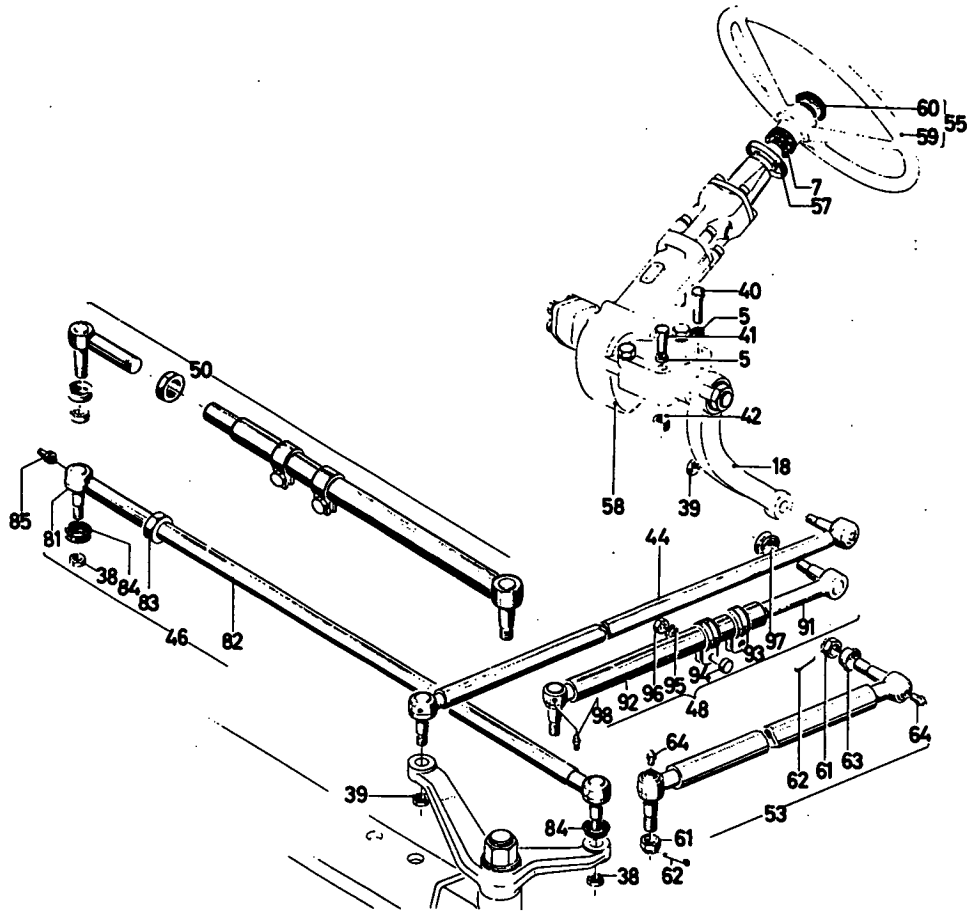

1145-37 500 5420

| Bild Nr. | Teile-Nr. | Stück-Zahl | Deutsch           | English           | Français           | Español            | Numer / Bemerkung         | ETK |
|----------|-----------|------------|-------------------|-------------------|--------------------|--------------------|---------------------------|-----|
| 1        | 238 1177  | 1          | KUGELGELENK       | BALL JOINT        | JOINT A ROTULE     | ARTICULAC-ESFERIC  |                           |     |
| 2        | 238 1200  | 1          | KUGELGELENK       | BALL JOINT        | JOINT A ROTULE     | ARTICULAC-ESFERIC  |                           |     |
| 3        | 238 1207  | 1          | STANGE            | ROD/BAR           | BARRE/TIGE/TRINGLE | BARRA/VARILLA      |                           |     |
| 4        | 238 1206  | 2          | KLEINSCHELLE      | CLIP              | COLLIER DE SERRAGE | ABRAZADERA APRIETO |                           |     |
| 5        | 116 764   | 4          | SICHERUNGSSCHEIBE | LOCKING WASHER    | RONDELLE SECURITE  | ARANDELA SEGURIDAD | 14 H 2203                 |     |
| 6        | 110 2691  | 2          | SECHSKANTMUTTER   | HEX-NUT           | ECROU 6 PANS       | TUERCA HEXAGONAL   | M10 DIN 934-M 2 A9C       |     |
| 7        | 337 082   | 1          | ABDECKKAPPE       | CAP               | CAPUCHON PROTECT   | CAPUCHON RECUBRIM. | 1171-37-01-12             | 01  |
| 8        | 113 574   | 1          | SECHSKANTMUTTER   | HEX-NUT           | ECROU 6 PANS       | TUERCA HEXAGONAL   | M18X1,5 DIN 936-M26-A9C   |     |
| 9        | 110 2400  | 2          | FEDERRING         | SPRING LOCKWASHER | RONDELLE GROMER    | ARANDELA ELASTICA  | A 10 DIN 128 A9C          |     |
| 10       | 233 8763  | 2          | KAPPE             | CAP               | CAPUCHON/CALOTTE   | SOMBRE-/CAPUCHON   |                           | 01  |
| 11       | 116 8225  | 2          | DRUCKSCHNIEKOPF   | LUBE FITTING      | GRAISSEUR A PRESS  | ENGRASADOR A PRES. | SA 0H 3360                |     |
| 15       | 111 1276  | 2          | SECHSKANTSCHRAUBE | HEX-BOLT          | VIS 6 PANS         | TORNILLO HEXAGONAL | M10X 45 DIN 931- 2.2-A9C  |     |
| 18       | 230 1603  | 1          | LENKSTOCKHEBEL    | DROP ARM          | LEVIER CDE DIRECT  | PALNCA-FLOQ-DIREC. |                           |     |
| 38       | 116 1630  | 2          | SICHERUNGSMUTTER  | LOCKING NUT       | ECROU D ARRET      | TUERCA AFIANZADORA | M12X1,5H 2132- 8          |     |
| 39       | 116 1628  | 2          | SICHERUNGSMUTTER  | LOCKING NUT       | ECROU D ARRET      | TUERCA AFIANZADORA | M14X1,5H 2132- 8          |     |
| 40       | 111 1707  | 2          | SECHSKANTSCHRAUBE | HEX-BOLT          | VIS 6 PANS         | TORNILLO HEXAGONAL | M14X 65 DIN 931-M 8.8 A9C |     |
| 41       | 110 1016  | 2          | SECHSKANTSCHRAUBE | HEX-BOLT          | VIS 6 PANS         | TORNILLO HEXAGONAL | M14X 80 DIN 931-M 8.8 A9C |     |
| 42       | 230 1516  | 2          | MUELSE            | SLEEVE            | BOUILLE            | CASQUILLO          |                           |     |
| 44       | 238 2762  | 1          | LENKSTANGE        | DRAG LINK         | BIELLE DE DIRECTIO | BARRA DIRECCION    |                           |     |
| 46       | 238 2756  | 1          | SPURSTANGE        | TRACK ROD         | BARRE ACCOUPLEMENT | BIELA ANCHO RODAD. |                           |     |
| 48       | 238 2765  | 1          | LENKSTANGE        | DRAG LINK         | BIELLE DE DIRECTIO | BARRA DIRECCION    | TELESKOP                  |     |
| 50       | 238 2763  | 1          | SPURSTANGE        | TRACK ROD         | BARRE ACCOUPLEMENT | BIELA ANCHO RODAD. | TELESKOP                  |     |
| 53       | 231 5341  | 1          | LENKSTANGE        | DRAG LINK         | BIELLE DE DIRECTIO | BARRA DIRECCION    | 8009-ALLRADAUSFUEHRUNG    |     |
| 55       | 232 1455  | 1          | LENKRAD           | STEERING WHEEL    | VOLANT DIRECTION   | VOLANTE DIRECCION  |                           |     |

| Bild Nr. | Teil-Nr. | Stück-Zahl | Deutsch           | English           | Français           | Español            | Nummer/Bemerkung                                  | ETK |
|----------|----------|------------|-------------------|-------------------|--------------------|--------------------|---|-----|
| 57       | 230 8077 | 1          | ABDECKUNG         | COVER             | RECouvreMENT       | RECUBRIMIENTO      | OBerteil  |     |
| 58       | 233 4403 | TM         | LENKSTÖCK         | COLUMN ASSY.      | COMMANDE DIRECTION | BLOQUE DIRECCION   | B333-TEILENUMMERN-LISTENBLATT<br>3006-37 500 5385 |     |
| 59       | 232 1792 | 1          | LENKRAD           | STEERING WHEEL    | VOLANT DIRECTION   | VOLANTE DIRECCION  |   |     |
| 60       | 338 7869 | 2          | ABDECKKAPPE       | CAP               | CAPUCHON PROTECT   | CAPUCHON RECUERIM. | 1125-37-05-05                                     |     |
| 61       | 111 3255 | 2          | KRONENMUTTER      | CASTLE NUT        | ECROU CRENELE      | TUERCA CORONA      | M14X1,5 DIN 937-65                                |     |
| 62       | 110 6437 | 2          | SPLINT            | SPLIT PIN         | GOUPILLE FENDUE    | PASADOR ALETAS     | 3 X 28DIN 94                                      |     |
| 63       | 233 8763 | 2          | KAPPE             | CAP               | CAPUCHON/CALOTTE   | SOMBRE-/CAPUCHON   |   | 01  |
| 64       | 116 8225 | 2          | DRUCKSCHMIERKOPF  | LUBE FITTING      | GRAISSEUR A PRESS  | ENGRASADOR A PRES. | SA 8H 3360  |     |
| 81       | 238 1204 | 1          | KUGELGELENK       | BALL JOINT        | JOINT A ROTULE     | ARTICULAC-ESFERIC  |   |     |
| 82       | 238 1205 | 1          | KUGELGELENK       | BALL JOINT        | JOINT A ROTULE     | ARTICULAC-ESFERIC  |   |     |
| 83       | 111 3174 | 1          | SECHSKANTMUTTER   | HEX-NUT           | ECROU 6 PANS       | TUERCA HEXAGONAL   | B381-MIT ROHR<br>M20X1,5 DIN 934-M65-PHOSPH       |     |
| 84       | 233 8763 | 2          | KAPPE             | CAP               | CAPUCHON/CALOTTE   | SOMBRE-/CAPUCHON   |   | 01  |
| 85       | 116 8255 | 1          | DRUCKSCHMIERKOPF  | LUBE FITTING      | GRAISSEUR A PRESS  | ENGRASADOR A PRES. | A 55 H 3481                                       |     |
| 91       | 238 1202 | 1          | KUGELGELENK       | BALL JOINT        | JOINT A ROTULE     | ARTICULAC-ESFERIC  |   |     |
| 92       | 238 1203 | 1          | KUGELGELENK       | BALL JOINT        | JOINT A ROTULE     | ARTICULAC-ESFERIC  | B381-MIT ROHR                                     |     |
| 93       | 233 8761 | 2          | KLEMMSCHELLE      | CLIP              | COLLIER DE SERRAGE | ABRAZADERA APRIETO |   |     |
| 94       | 111 1298 | 2          | SECHSKANTSCHRAUBE | HEX-BOLT          | VIS 6 PANS         | TORNILLO HEXAGONAL | M30X 45 DIN 931-M 8-8 A4C                         |     |
| 95       | 110 2800 | 2          | FEDERRING         | SPRING LOCKWASHER | RONDELLE GROMER    | ARANDELA ELASTICA  | A 30 DIN 128 A4C                                  |     |
| 96       | 110 2659 | 2          | SECHSKANTMUTTER   | HEX-NUT           | ECROU 6 PANS       | TUERCA HEXAGONAL   | M30 DIN 934-M 2 A4C                               |     |
| 97       | 233 5726 | 2          | KAPPE             | CAP               | CAPUCHON/CALOTTE   | SOMBRE-/CAPUCHON   |   | 01  |
| 98       | 116 8225 | 1          | DRUCKSCHMIERKOPF  | LUBE FITTING      | GRAISSEUR A PRESS  | ENGRASADOR A PRES. | SA 8H 3360  |     |

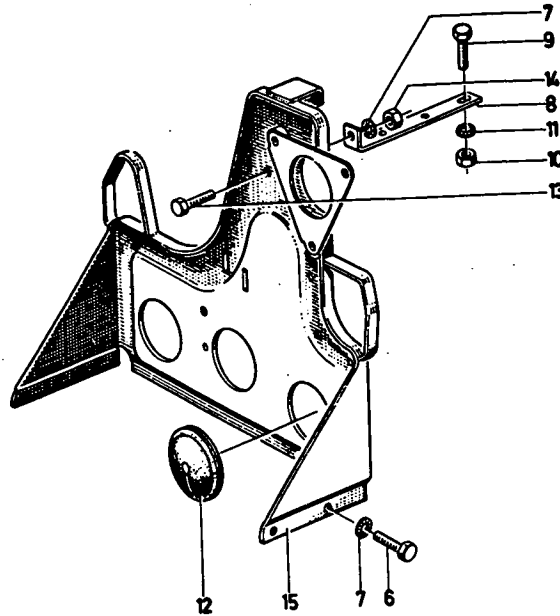

1003-38 500 4219

| Bld. Nr. | Teil-Nr. | Stück-Zahl | Deutsch           | English          | Français           | Español            | Numer/Bemerkung           | ETK |
|----------|----------|------------|-------------------|------------------|--------------------|--------------------|---------------------------|-----|
| 6        | 111 2299 | 4          | SECHSKANTSCHRAUBE | HEX-BOLT         | VIS 6 PANS         | TORNILLO HEXAGONAL | M 8 X 12 DIN 933- 8-8-A4C |     |
| 7        | 116 9689 | 5          | SICHERUNGSSCHEIBE | LOCKING WASHER   | RONDELLE SECURITE  | ARANDELA SEGURIDAD | 6 H 2203                  |     |
| 8        | 230 4514 | 1          | STREBE            | BRACE/STRUT      | JAMBE DE FORCE     | TIRANTE            |                           |     |
| 9        | 111 2251 | 1          | SECHSKANTSCHRAUBE | HEX-BOLT         | VIS 6 PANS         | TORNILLO HEXAGONAL | M 6 X 15 DIN 933- 8-8-A4C |     |
| 10       | 111 2813 | 1          | SECHSKANMUTTER    | HEX-NUT          | ECROU 6 PANS       | TUERCA HEXAGONAL   | M 6 DIN 934-M 8 A4C       |     |
| 11       | 116 7194 | 1          | SICHERUNGSSCHEIBE | LOCKING WASHER   | RONDELLE SECURITE  | ARANDELA SEGURIDAD | 6 H 2203                  |     |
| 12       | 232 1018 | 1          | DECKEL            | COVER            | COUVERCLE          | TAPA               |                           |     |
| 13       | 111 2341 | 1          | SECHSKANTSCHRAUBE | HEX-BOLT         | VIS 6 PANS         | TORNILLO HEXAGONAL | M 8 X 30 DIN 933- 8-8-A4C |     |
| 14       | 111 2824 | 1          | SECHSKANMUTTER    | HEX-NUT          | ECROU 6 PANS       | TUERCA HEXAGONAL   | M 8 DIN 934-M 8 A4C       |     |
| 15       | 233 2386 | 1          | TRENNWAND         | BULKHEAD/PARTIT. | CLOISON SEPARATION | TABIQUE SEPARACION |                           |     |

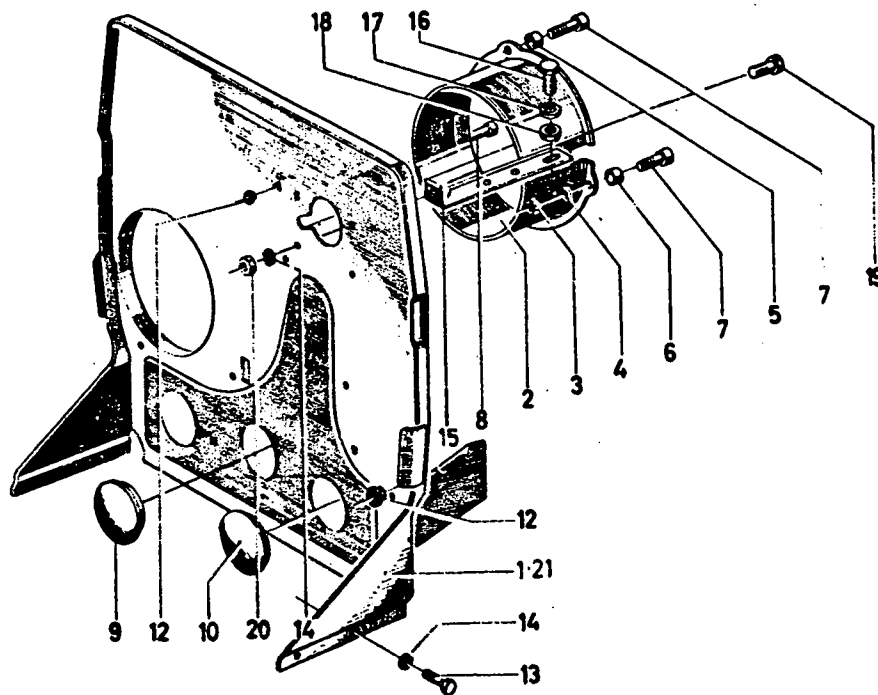

1005-38 500 3001

| Bld. Nr. | Teile-Nr. | Stück-Zahl | Deutsch           | Englisch          | Français           | Español            | Nummer/Bemerkung             | ETK |
|----------|-----------|------------|-------------------|-------------------|--------------------|--------------------|------------------------------|-----|
| 1.       | 232 5690  | 1          | TRENNWAND         | BULKHEAD/PARTIT.  | CLOISON SEPARATION | TABIQUE SEPARACION | 8139, FUER TROCKENLUFTFILTER |     |
| 2        | 230 4564  | 1          | LUFTLEITRING      | GUIDE RING        | BAGUE GUIDE-AIR    | ANILLO GUIA AIRE   |                              |     |
| 3        | 111 2803  | 3          | SECHSKANTMUTTER   | HEX-NUT           | ECROU 6 PANS       | TUERCA HEXAGONAL   | M 5 DIN 934-M 8 A4C          |     |
| 4        | 110 7089  | 6          | SCHEIBE           | DISC/PANE/PLATE   | RONDELLE/DISQUE    | DISCO              | A 5-DIN 125-ST-A4C           |     |
| 5        | 231 6098  | 2          | ABSTANDHUELSE     | SPACER SLEEVE     | DOUILLE ECARTEN    | CASQ-DISTANCIARIO  |                              |     |
| 6        | 231 9551  | 1          | ABSTANDHUELSE     | SPACER SLEEVE     | DOUILLE ECARTEN    | CASQ-DISTANCIARIO  |                              |     |
| 7        | 110 5593  | 2          | ZYLINDERSCHRAUBE  | CHEESE-HEAD SCREW | VIS TETE CYLINDR.  | TORN-CBZA-CILIND.  | AM 5 X 25DIN 84- 4-8-A4C     |     |
| 8        | 112 3582  | 1          | ZYLINDERSCHRAUBE  | CHEESE-HEAD SCREW | VIS TETE CYLINDR.  | TORN-CBZA-CILIND.  | AM 5 X 30DIN 84- 4-8-A4C     |     |
| 9        | 231 1488  | 2          | DECKEL            | COVER             | COUVERCLE          | TAPA               |                              |     |
| 10       | 232 1018  | 1          | DECKEL            | COVER             | COUVERCLE          | TAPA               |                              |     |
| 12       | 116 7427  | 1          | GUMMITUELLE       | RUBBER GROMMET    | GAINE CAOUTCHOUC   | FUNDA CAUCHO       | Ø17 X24 X 2 H 2928           |     |
| 13       | 111 2299  | 4          | SECHSKANTSCHRAUBE | HEX-BOLT          | VIS 6 PANS         | TORNILLO HEXAGONAL | M 8 X 12 DIN 933- 8-8-A4C    |     |
| 14       | 116 9689  | 5          | SICHERUNGSSCHEIBE | LOCKING WASHER    | RONDELLE SECURITE  | ARANDELA SEGURIDAD | 8 H 2203                     |     |
| 15       | 230 4514  | 1          | STREBE            | BRACE/STRUT       | JAMBE DE FORCE     | TIRANTE            |                              |     |
| 16       | 111 2251  | 1          | SECHSKANTSCHRAUBE | HEX-BOLT          | VIS 6 PANS         | TORNILLO HEXAGONAL | M 6 X 15 DIN 933- 8-8-A4C    |     |
| 17       | 116 7194  | 1          | SICHERUNGSSCHEIBE | LOCKING WASHER    | RONDELLE SECURITE  | ARANDELA SEGURIDAD | 6 H 2203                     |     |
| 18       | 111 2813  | 1          | SECHSKANTMUTTER   | HEX-NUT           | ECROU 6 PANS       | TUERCA HEXAGONAL   | M 6 DIN 934-M 8 A4C          |     |
| 19       | 111 2341  | 1          | SECHSKANTSCHRAUBE | HEX-BOLT          | VIS 6 PANS         | TORNILLO HEXAGONAL | M 8 X 30 DIN 933- 8-8-A4C    |     |
| 20       | 111 2824  | 1          | SECHSKANTMUTTER   | HEX-NUT           | ECROU 6 PANS       | TUERCA HEXAGONAL   | M 8 DIN 934-M 8 A4C          |     |
| 21       | 237 1658  | 1          | TRENNWAND         | BULKHEAD/PARTIT.  | CLOISON SEPARATION | TABIQUE SEPARACION | 8140, FUER OELBADFILTER      |     |



MOTORHAUBE  
ENGINE HOOD  
CAPOT MOTEUR  
CAPOT DEL MOTOR

7876/6678  
7868/0402

1001-41 500 4220

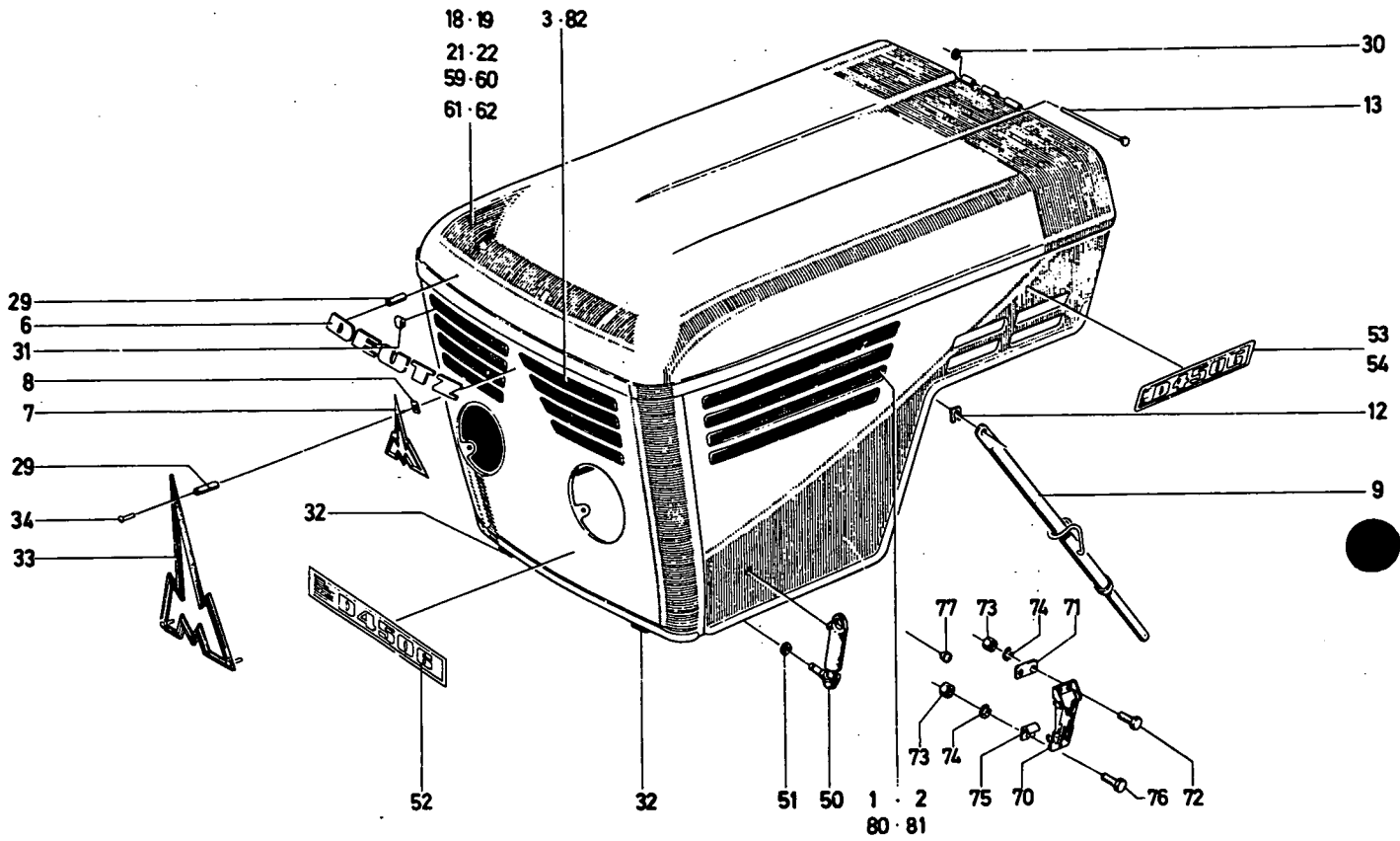

| Bld. Nr. | Teil-Nr. | Stück-Zahl | Deutsch           | English          | Français           | Español            | Nummer/Bemerkung                                     | ETK |
|----------|----------|------------|-------------------|------------------|--------------------|--------------------|--|-----|
| 1        | 233 4548 | 1          | SCHUTZGITTER      | GRILLE/GRID      | GRILLE PROTECTRICE | REJILLA PROTECCION | B267-RECHTS<br>B382-MASCHINENWEITE 5-                |     |
| 2        | 233 4549 | 1          | SCHUTZGITTER      | GRILLE/GRID      | GRILLE PROTECTRICE | REJILLA PROTECCION | B195-LINKS<br>B382-MASCHINENWEITE 5                  |     |
| 3        | 233 4546 | 1          | SCHUTZGITTER      | GRILLE/GRID      | GRILLE PROTECTRICE | REJILLA PROTECCION | B396-VORN<br>B382-MASCHINENWEITE 5                   |     |
| 6        | 123 0675 | 1          | FIRMENSCHILD      | NAMEPLATE/NAME   | PLAQUE DE FIRME    | ROTULO FABRICA     | 4 303 A 182  |     |
| 7        | 123 8017 | 1          | FIRMENZEICHEN     | TRADE MARK       | EMBLEME DE FIRME   | EMBLEMA MARCA      | 4 315 A  |     |
| 8        | 116 7204 | 3          | SICHERUNGSBLECH   | LOCKING PLATE    | TOLE DE SECURITE   | CHAPA SEGURIDAD    | A2.5 H 2219  |     |
| 7        | 230 4568 | 1          | HAUBENAUFSTELLER  | HOOD SUPPORT     | LEVE-CAPOT         | ELEVA-CAPOT        |  |     |
| 12       | 123 1098 | 1          | BOLZENSICHERUNG   | LOCK/COTTER      | FREIN DE BOULON    | AFIANZA-BULON      | 2 205 C 1  |     |
| 13       | 230 4203 | 1          | BOLZEN            | PIN/BOLT/STUD    | BOULON/AXE         | BULON              |  |     |
| 18       | 230 4160 | 1          | MOTORHAUBE        | ENGINE HOOD      | CAPOT MOTEUR       | CAPOT MOTOR        | B082-FUER AUSPUFF U-SCHWEINWERFER NORMAL-            |     |
| 19       | 230 4188 | 1          | MOTORHAUBE        | ENGINE HOOD      | CAPOT MOTEUR       | CAPOT MOTOR        | B083-FUER AUSPUFF NACH OBEN<br>SCHWEINWERFER NORMAL- |     |
| 21       | 230 4189 | 1          | MOTORHAUBE        | ENGINE HOOD      | CAPOT MOTEUR       | CAPOT MOTOR        | B253-0HNE SCHEINWERFER,<br>AUSPUFF NORMAL-           |     |
| 22       | 230 4190 | 1          | MOTORHAUBE        | ENGINE HOOD      | CAPOT MOTEUR       | CAPOT MOTOR        | B254-0HNE SCHEINWERFER,<br>AUSPUFF NACH OBEN-        |     |
| 29       | 123 0674 | 14         | TUELLE            | GROMMET          | BOJILLE            | FUNDA              | 7 565 M 1  |     |
| 30       | 123 0790 | 2          | SICHERUNGSSCHEIBE | LOCKING WASHER   | RONDELLE SECURITE  | ARANDELA SEGURIDAD | 2 217 B 6  |     |
| 31       | 233 8960 | 10         | KLAMMER           | CLAMP/CLIP       | PINCE/AGRAFE/ATTA  | PINZA              |  |     |
| 32       | 233 1552 | 2          | GUMMIPUFFER       | RUBBER PAD       | TAMPON CAOUTCHOUC  | TOPE CAUCHO        |  |     |
| 33       | 123 1099 | 1          | FIRMENZEICHEN     | TRADE MARK       | EMBLEME DE FIRME   | EMBLEMA MARCA      | 4 315 A 4  |     |
| 34       | 123 1100 | 4          | HALBRUNDNIET      | ROUND-HEAD RIVET | RIVET A TETE DEMI  | REMACHE SEMIRRED-  | 2 403 A 1  |     |



| Bkl<br>Nr. | Teil-Nr. | Stück-<br>Zahl | Deutsch           | English           | Français           | Español            | Nummer/Bemerkung   | ETK |
|------------|----------|----------------|-------------------|-------------------|--------------------|--------------------|--|-----|
| 50         | 231 5697 | 2              | HAUBENHALTER      | HOOD FASTENER     | ATTACHE DE CAPOT   | SUJETADOR CAPOT    |  |     |
| 51         | 112 4654 | 4              | SCHEIBE           | DISC/PANE/PLATE   | RONDILLE/DISQUE    | DISCO              | 6,40IN 933-ST-A9C  |     |
| 52         | 121 2794 | 1              | TYPSCCHILD        | NAME PLATE        | PLAQUE DE TYPE     | ROTULO TIPO        |  |     |
| 53         | 121 2795 | 1              | TYPSCCHILD        | NAME PLATE        | PLAQUE DE TYPE     | ROTULO TIPO        | 8267-RECHTS  |     |
| 54         | 121 2796 | 1              | TYPSCCHILD        | NAME PLATE        | PLAQUE DE TYPE     | ROTULO TIPO        | 8195-LINKS   |     |
| 57         | 237 3603 | 1              | MOTORHAUBE        | ENGINE HOOD       | CAPOT MOTEUR       | CAPOT MOTOR        | 8131-F-AUSPUFF U-SCHWEINWERFER<br>NORMAL-ANSAUGUNG V-OBEN- |     |
| 60         | 237 3604 | 1              | MOTORHAUBE        | ENGINE HOOD       | CAPOT MOTEUR       | CAPOT MOTOR        | 8132-F-AUSPUFF U-ANSAUGUNG<br>OBEN-SCHWEINWERFER NORMAL    |     |
| 61         | 237 3605 | 1              | MOTORHAUBE        | ENGINE HOOD       | CAPOT MOTEUR       | CAPOT MOTOR        | 8255-0HNE SCHWEINWEG-AUSPUFF<br>NORMAL-ANSAUGUNG V-OBEN-   |     |
| 62         | 237 3606 | 1              | MOTORHAUBE        | ENGINE HOOD       | CAPOT MOTEUR       | CAPOT MOTOR        | 8256-0HNE SCHWEINWERFER<br>AUSPUFF U-ANSAUGUNG OBEN        |     |
| 70         | 238 8686 | 1              | SPANNVERSCHLUSS   | FASTENER          | FERN A RES RAPPEL  | CIERRE TENSOR      |  |     |
| 71         | 237 7014 | 1              | PLATTE            | PLATE             | PLAQUE             | PLACA              |  |     |
| 72         | 111 2251 | 2              | SECHSKANTSCHRAUBE | HEX-BOLT          | VIS 6 PANS         | TORNILLO HEXAGONAL | M 6 X 15 DIN 933- 8-8-A9C                                  |     |
| 73         | 111 2813 | 3              | SECHSKANTMUTTER   | HEX-NUT           | ECROU 6 PANS       | TUERCA HEXAGONAL   | M 6 DIN 934-M 8 A9C  |     |
| 74         | 110 2797 | 3              | FEDERRING         | SPRING LOCKWASHER | RONDILLE GROMER    | ARANDELA ELASTICA  | A 6 DIN 128 A9C  |     |
| 75         | 237 7012 | 1              | HAKEN             | HOOK              | CROCHET            | GANCHO             |  |     |
| 76         | 112 3749 | 1              | SECHSKANTSCHRAUBE | HEX-BOLT          | VIS 6 PANS         | TORNILLO HEXAGONAL | M 6 X 25 DIN 933- 8-8-A9C                                  |     |
| 77         | 121 4582 | 1              | KNOPF             | BUTTON/KNOB       | BOUION             | BOTON              | 7 565 D 5 IN KLAMMER                                       |     |
| 80         | 233 4503 | 1              | SCHUTZGITTER      | GRILLE/GRID       | GRILLE PROTECTRICE | REJILLA PROTECCION | 8267-RECHTS<br>8382-MASCHENWEITE 1                         |     |
| 81         | 233 4504 | 1              | SCHUTZGITTER      | GRILLE/GRID       | GRILLE PROTECTRICE | REJILLA PROTECCION | 8195-LINKS<br>8382-MASCHENWEITE 1                          |     |
| 82         | 233 4210 | 1              | SCHUTZGITTER      | GRILLE/GRID       | GRILLE PROTECTRICE | REJILLA PROTECCION | 8346-VORN<br>8382-MASCHENWEITE 1                           |     |

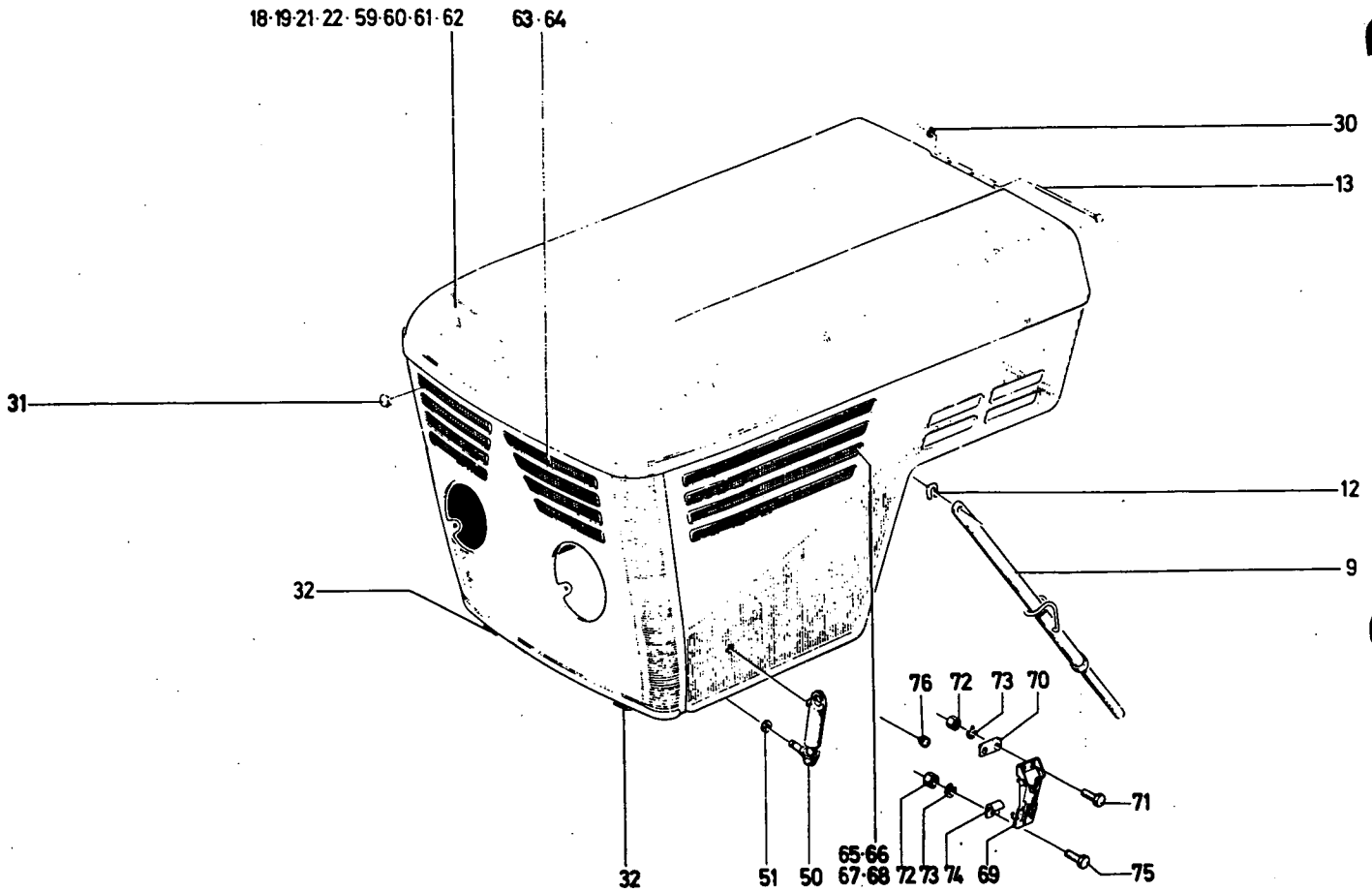

1001-41 501 7089

| Bild Nr. | Teile-Nr. | Stück-Zahl | Deutsch           | English         | Français           | Español            | Nummer/Bemerkung  | ETK |
|----------|-----------|------------|-------------------|-----------------|--------------------|--------------------|---|-----|
| 9        | 230 4568  | 1          | HAUBENAUFSTELLER  | HOOD SUPPORT    | LEVE-CAPOT         | ELEVA-CAPOT        |   |     |
| 12       | 121 1098  | 1          | BOLZENSICHERUNG   | LOCK/COTTER     | FREIN DE BOULON    | AFIANZA-BULON      | 2 205 C 1   |     |
| 13       | 230 4203  | 1          | BOLZEN            | PIN/BOLT/STUD   | BOULON/AXE         | BULON              |   |     |
| 14       | 230 4160  | 1          | MOTORHAUBE        | ENGINE HOOD     | CAPOT MOTEUR       | CAPOT MOTOR        | B082-FUER AUSPUFF UND SCHEINWERFER NORMAL                 |     |
| 17       | 230 4188  | 1          | MOTORHAUBE        | ENGINE HOOD     | CAPOT MOTEUR       | CAPOT MOTOR        | B083-FUER AUSPUFF NACH OBEN UND SCHEINWERFER NORMAL       |     |
| 21       | 230 4189  | 1          | MOTORHAUBE        | ENGINE HOOD     | CAPOT MOTEUR       | CAPOT MOTOR        | B253-0HNE SCHEINWERFER AUSPUFF NORMAL                     |     |
| 22       | 230 4190  | 1          | MOTORHAUBE        | ENGINE HOOD     | CAPOT MOTEUR       | CAPOT MOTOR        | B254-0HNE SCHEINWERFER, AUSPUFF NACH, OBEN                |     |
| 30       | 121 0740  | 2          | SICHERUNGSSCHEIBE | LOCKING WASHER  | RONDELLE SECURITE  | ARANDELA SEGURIDAD | 2 217 B 6   |     |
| 31       | 233 8960  | 10         | U-KLENNE          | U-CLAMP/CLIP    | BORNE/PINCE EN U   | BORNE/PINZA EN U   |   |     |
| 32       | 231 1552  | 2          | GUMMIPUFFER       | RUBBER PAD      | TAMPON CAOUTCHOUC  | TOPE CAUCHO        |   |     |
| 50       | 231 5697  | 2          | HAUBENHALTER      | HOOD FASTENER   | ATTACHE DE CAPOT   | SUJETADOR CAPOT    |   |     |
| 51       | 112 4654  | 4          | SCHEIBE           | DISC/PANE/PLATE | RONDELLE/DISQUE    | DISCO              | 6,4 DIN 433 A4C   |     |
| 59       | 237 3603  | 1          | MOTORHAUBE        | ENGINE HOOD     | CAPOT MOTEUR       | CAPOT MOTOR        | B131-FUER AUSPUFF SCHEINWERFER NORMAL, ANSAUGUNG VON OBEN |     |
| 60       | 237 3604  | 1          | MOTORHAUBE        | ENGINE HOOD     | CAPOT MOTEUR       | CAPOT MOTOR        | B132-FUER AUSPUFF+ANSAUGUNG OBEN, SCHEINWERFER NORMAL     |     |
| 61       | 237 3605  | 1          | MOTORHAUBE        | ENGINE HOOD     | CAPOT MOTEUR       | CAPOT MOTOR        | B255-0HNE SCHEINWERFER AUSPUFF NORMAL, ANSAUGUNG VON OBEN |     |
| 62       | 237 3606  | 1          | MOTORHAUBE        | ENGINE HOOD     | CAPOT MOTEUR       | CAPOT MOTOR        | B256-0HNE SCHEINWERFER, AUSPUFF UND ANSAUGUNG VON OBEN    |     |
| 63       | 233 4210  | 1          | SCHUTZGITTER      | GRILLE/GRID     | GRILLE PROTECTRICE | REJILLA PROTECCION | B382-NASCHENWEITE 1                                       |     |

Für diese Zeichnung behalten wir uns alle Rechte nach DIN 34 vor.

Die Maße werden vom Besteller (Empfänger) besonders beachtet. Maßzahlen in Klammern (76) gelten nicht für die Kontrolle.

|  |  |  |  |
|--|--|--|--|
|  |  |  |  |
|  |  |  |  |
|  |  |  |  |
|  |  |  |  |

| Ähnlichkeit-Schlüssel-Nr. |  |  |  |
|---------------------------|--|--|--|
|                           |  |  |  |

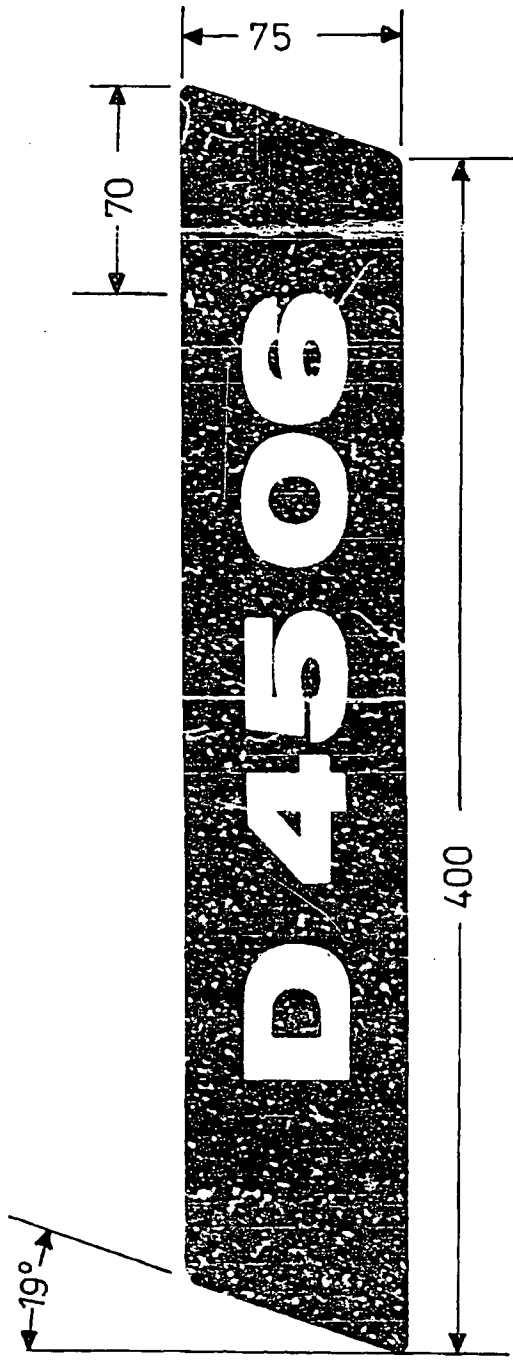

Angaben:

- 1. Alle Eckradien = 5 mm
- 2. Konstr.-Nr. 4314010 auf dem rückseitigen Schutzpapier gut lesbar angebracht
- 3. Folienfarbe: schwarzblau, RAL 5004; Schrift: silber, matt
- 4. Ausführung: selbstklebende Polyesterfolie nach Liefervorschrift 8025-02-6504
- 5. Bei Herstellung KHD-Vorlage verwenden

|        |          |  |  |             |                    |         |
|--------|----------|--|--|-------------|--------------------|---------|
| Bauart | 1004     | Freimaßtoleranzen<br>C mittel<br>DIN 7168<br>Kanten gratfrei | Oberflächen-<br>Kennzeichng.<br>nach<br>DIN 3142 | Maßstab     | 1 : 2,5            | Gewicht |
|        |          |  |  | Werkstoff   | S.O.               |         |
|        |          |  |  | Rohteil-Nr. |                    |         |
|        |          | Datum  | Name   | Benennung   |                    |         |
|        |          | Bearb. 17-5-77   | EMUNDS   | TYPSCILD    |                    |         |
|        |          | Gepr.  | <i>EM</i>  |             |                    |         |
|        |          | Norm   | <i>EM</i>  |             |                    |         |
|        |          | Abt. SR  | Ges.   |             |                    |         |
|        |          | Klöckner-Humboldt-Deutz AG                                   |  | Nr.         | 4314010 EE 1004-71 |         |
|        |          |  |  |             |                    | Blatt   |
|        |          | Urspr. M1002-00-13   |  | Ers. für:   | von Bl.            |         |
|        | Änderung | Datum  | Name   | Ers. durch: |                    |         |



Für diese Zeichnung behalten wir uns alle Rechte nach DIN 34 vor.

Die Maße werden vom Besteller (Empfänger) besonders beachtet. Maßzahlen in Klammern (76) gelten nicht für die Kontrolle.

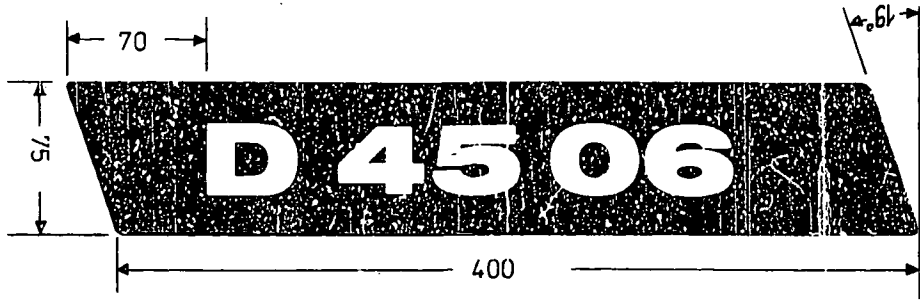

Angaben:

1. Alle Eckradien  $\approx$  5 mm
2. Konstr.-Nr. 4314009 auf dem rückseitigen Schutzpapier gut lesbar angebracht
3. Folienfarbe: schwarzblau, RAL 5004; Schrift: silber, matt
4. Ausführung: selbstklebende Polyesterfolie nach Liefervorschrift 8025-02-6504
5. Bei Herstellung KHD-Vorlage verwenden

|        |     |       |                 |        |              |           |              |                  |       |     |
|--------|-----|-------|-----------------|--------|--------------|-----------|--------------|------------------|-------|-----|
| Zust.  | And | Datum | Name            | Urspr. | M 1002-00-43 | Ers. für: | Nr.          | 4314009EE1004-71 | Blatt | 6/1 |
|        |     |       | KHD             |        |              |           |              |                  |       |     |
| Bauart |     |       | Freiholdbrunnen |        | Oberflächen- |           | Maststab     |                  |       |     |
| 1004   |     |       | C mittel        |        | Kerzsching.  |           | 1 : 2,5      |                  |       |     |
|        |     |       | DIN 7768        |        | nach         |           | Werstoff     |                  |       |     |
|        |     |       | Kanten gratfrei |        | DIN 3142     |           | Rohrleit-Nr. |                  |       |     |
|        |     |       | Datum           |        | Name         |           | Benennung    |                  |       |     |
|        |     |       | Bearb. 15.5.77  |        | EUVUS        |           | TYPSCCHILD   |                  |       |     |
|        |     |       | Gegr.           |        |              |           |              |                  |       |     |
|        |     |       | Norm            |        |              |           |              |                  |       |     |
|        |     |       | Abt. SQ         |        |              |           |              |                  |       |     |
|        |     |       | Ges.            |        |              |           |              |                  |       |     |

|  |  |  |
|--|--|--|
|  |  |  |
|  |  |  |
|  |  |  |
|  |  |  |
|  |  |  |
|  |  |  |
|  |  |  |
|  |  |  |
|  |  |  |
|  |  |  |

|                           |  |
|---------------------------|--|
| Ähnlichkeit-Schlüssel-Nr. |  |
|                           |  |
|                           |  |
|                           |  |



| Bld<br>Nr. | Teil-Nr. | Stück-<br>Zahl | Deutsch           | English           | Français           | Español            | Nummer/Bemerkung                   | ETK |
|------------|----------|----------------|-------------------|-------------------|--------------------|--------------------|------------------------------------|-----|
| 64         | 238 2415 | 1              | SCHUTZGITTER      | GRILLE/GRID       | GRILLE PROTECTRICE | REJILLA PROTECCION | 8382-MASCHENWEITE 5                |     |
| 65         | 233 4504 | 1              | SCHUTZGITTER      | GRILLE/GRID       | GRILLE PROTECTRICE | REJILLA PROTECCION | 8195-LINKS<br>8382-MASCHENWEITE 1  |     |
| 66         | 238 2417 | 1              | SCHUTZGITTER      | GRILLE/GRID       | GRILLE PROTECTRICE | REJILLA PROTECCION | 8195-LINKS<br>8382-MASCHENWEITE 5  |     |
| 67         | 233 4503 | 1              | SCHUTZGITTER      | GRILLE/GRID       | GRILLE PROTECTRICE | REJILLA PROTECCION | 8267-RECHTS<br>8382-MASCHENWEITE 1 |     |
| 68         | 238 2416 | 1              | SCHUTZGITTER      | GRILLE/GRID       | GRILLE PROTECTRICE | REJILLA PROTECCION | 8267-RECHTS<br>8382-MASCHENWEITE 5 |     |
| 69         | 238 8686 | 1              | SPANNVERSCHLUSS   | FASTENER          | FERN A RES RAPPEL  | CIERRE TENSOR      |                                    |     |
| 70         | 237 7034 | 1              | PLATTE            | PLATE             | PLAQUE             | PLACA              |                                    |     |
| 71         | 111 2251 | 2              | SECHSKANTSCHRAUBE | HEX-BOLT          | VIS 6 PANS         | TORNILLO HEXAGONAL | M6X15 DIN 933-M8-8-A9C             |     |
| 72         | 111 2813 | 3              | SECHSKANTMUTTER   | HEX-NUT           | ECROU 6 PANS       | TUERCA HEXAGONAL   | M 6 DIN 934-M8-A9C                 |     |
| 73         | 110 2797 | 3              | FEDERRING         | SPRING LOCKWASHER | RONDELLE GROVER    | ARANDELA ELASTICA  | A 6 DIN 128 A9C                    |     |
| 74         | 237 7012 | 1              | HAKEN             | HOOK              | CROCHET            | GANCHO             |                                    |     |
| 75         | 112 3749 | 1              | SECHSKANTSCHRAUBE | HEX-BOLT          | VIS 6 PANS         | TORNILLO HEXAGONAL | M6X25 DIN 933-8-8-A9C              |     |
| 76         | 121 4582 | 1              | KNOPF             | BUTTON/KNOB       | BOUTON             | BOTON              | 7565 D 5                           |     |

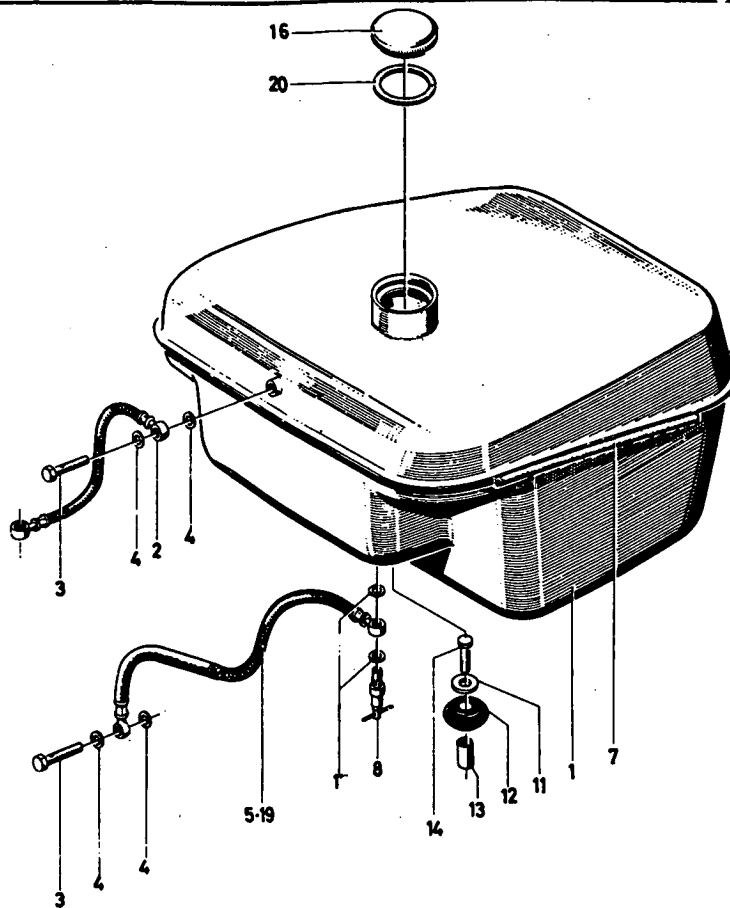

1005-42 500 3003

| Bild Nr. | Teil-Nr. | Stück-Zahl | Deutsch           | English         | Français           | Español            | Nummer/Bemerkung              | ETK |
|----------|----------|------------|-------------------|-----------------|--------------------|--------------------|-------------------------------|-----|
| 1        | 231 9713 | 1          | KRAFTST.-BEHÄLTER | FUEL TANK       | RESERV A COMBUST   | TANQUE COMBUSTIBLE |                               |     |
| 2        | 338 8595 | 1          | KRAFTSTOFFLEITUNG | FUEL LINE       | CONDUITE COMBUST   | TUBERIA COMBUSTIBL |                               | 01  |
| 3        | 111 9246 | 2          | HOHLSCHRAUBE      | BANJO BOLT      | VIS BANJO          | TORNILLO RACOR     | A 8 DIN 7623 VZKC             |     |
| 4        | 111 8688 | 4          | DICHTRING         | WASHER          | BAGUE D ETANCHEITE | ANILLO DE JUNTA    | A 14 X 18 DIN 7603-CU         |     |
| 5        | 231 1696 | 1          | SCHLAUCHLEITUNG   | HOSE            | CONDUITE FLEXIBLE  | MANGUERA           |                               | 01  |
| 7        | 116 2740 | 2          | GUMMIPROFIL       | RUBBER SECTION  | PROFIL CAOUTCHOUC  | PERFIL CAUCHO      | V 1.5 X 8 X 9 X 470H 7560-SGB |     |
| 8        | 231 1411 | 1          | ABSPERRHAHN       | SHUT-OFF COCK   | ROBINET D ARRET    | GRIFO CIERRE PASO  |                               |     |
| 11       | 231 2618 | 1          | SCHEIBE           | DISC/PANE/PLATE | RONDELLE/DISQUE    | DISCO              |                               |     |
| 12       | 231 0888 | 1          | GUMMIPUFFER       | RUBBER PAD      | TAMPON CAOUTCHOUC  | TOPE CAUCHO        |                               |     |
| 13       | 231 2619 | 1          | ABSTANDROHR       | SPACER TUBE     | TUBE ECARTEMENT    | TUBO DISTANCIARIO  |                               |     |
| 14       | 111 1168 | 1          | SECHSKANTMUTTER   | HEX-NUT         | ECROU 6 PANS       | TUERCA HEXAGONAL   | M 8 X 60 DIN 931- 8-8-A4C     |     |
| 16       | 124 4823 | 1          | BECKEL            | COVER           | COUVERCLE          | TAPA               |                               |     |
| 17       | 111 8673 | 2          | DICHTRING         | WASHER          | BAGUE D ETANCHEITE | ANILLO DE JUNTA    | A 12 X 15.5DIN 7603-CU        |     |
| 19       | 233 2555 | 1          | SCHLAUCHLEITUNG   | HOSE            | CONDUITE FLEXIBLE  | MANGUERA           | 8097-FUER DOPPELFILTER        | 01  |
| 20       | 121 1299 | 1          | DICHTRING         | WASHER          | BAGUE D ETANCHEITE | ANILLO DE JUNTA    |                               | 01  |





KRAFTSTOFFFILTER MIT WASSERABSCHIEDER  
 FUEL FILTER WITH WATER SEPARATOR  
 FILTRE A COMBUSTIBLE AVEC SEPARATEUR D EAU  
 FILTRO DE COMBUSTIBLE CON SEPARADOR DE AGUE

1005-42 500 3004

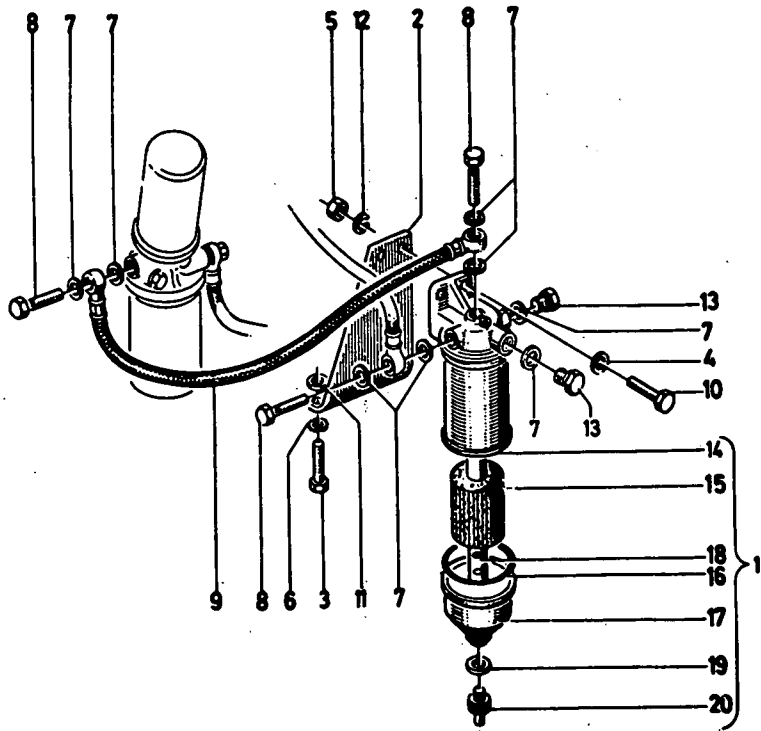

1005-42 500 3004

| Bild Nr. | Teil-Nr. | Stück-Zahl | Deutsch            | English           | Français           | Español            | Nummer/Bemerkung           | ETK |
|----------|----------|------------|--------------------|-------------------|--------------------|--------------------|----------------------------|-----|
| 1        | 233 2632 | 1          | KRAFTSTOFFFILTER   | FUEL FILTER       | FILTRE A COMBUST   | FILTRO COMBUSTIBLE |                            |     |
| 2        | 233 2628 | 1          | KONSOLE            | BRACKET/CONSOLE   | CONSOLE            | CONSOLA            |                            |     |
| 3        | 111 2350 | 2          | SECHSKANTSCHRAUBE  | HEX-BOLT          | VIS 6 PANS         | TORNILLO HEXAGONAL | M 8 X 35 DIN 933- 8-8-A4C  |     |
| 4        | 110 7105 | 2          | SCHEIBE            | DISC/PANE/PLATE   | RONDELLE/DISQUE    | DISCO              | A10.5DIN 125-ST-A4C        |     |
| 5        | 110 2659 | 2          | SECHSKANTHÜTTER    | HEX-NUT           | ECROU 6 PANS       | TUERCA HEXAGONAL   | M10 DIN 934-N 8 A4C        |     |
| 6        | 110 1492 | 2          | ZAHNSCHEIBE        | TOOTHED WASHER    | RONDELLE DENTEE    | ARANDELA DENTADA   | A 8.2DIN 6797 VZKC         |     |
| 7        | 111 8688 | 5          | DICHTRING          | WASHER            | BAGUE D ETANCHEITE | ANILLO DE JUNTA    | A 14 X 18 DIN 7603-CU      |     |
| 8        | 111 9246 | 2          | MONLSCHRAUBE       | BANJO BOLT        | VIS BANJO          | TORNILLO RACOR     | A 8 DIN 7623 VZKC          |     |
| 9        | 126 6161 | 1          | SCHLAUCHLEITUNG    | HOSE              | CONDUITE FLEXIBLE  | MANGUERA           | 8934-80-03-170             | 01  |
| 10       | 111 2429 | 2          | SECHSKANTSCHRAUBE  | HEX-BOLT          | VIS 6 PANS         | TORNILLO HEXAGONAL | M10 X 30. DIN 933- 8-8-A4C |     |
| 11       | 121 6143 | 2          | RING               | RING              | BAGUE/ANNEAU       | ANILLO             | 2 329 8 1                  |     |
| 12       | 110 2800 | 2          | FEDERRING          | SPRING LOCKWASHER | RONDELLE GROMER    | ARANDELA ELASTICA  | A 10 DIN 126 A4C           |     |
| 13       | 111 8963 | 1          | VERSCHLUSSSCHRAUBE | SCREW PLUG        | BOUCHON FILETE     | TAPON ROSCADO      | M14X1.5 DIN 7604 VZKC      |     |
| 14       | 233 0283 | 1          | FLANSCH            | FLANGE            | BRIDE/COLLET       | BRIDA              |                            |     |
| 15       | 213 3558 | 1          | FILTREREINSATZ     | ELEMENT           | CART.FILTRANTE     | ELEMENTO FILTRO    |                            | 01  |
| 16       | 213 3562 | 1          | DICHTRING          | WASHER            | BAGUE D ETANCHEITE | ANILLO DE JUNTA    |                            | 01  |
| 17       | 213 3557 | 1          | WASSERBEHALTER     | WATER RESERVOIR   | RESERVOIR D EAU    | RECIPIENTE AGUA    |                            |     |
| 18       | 213 3559 | 1          | SPANNBOLZEN        | CLAMPING PIN      | AXE DE SERRAGE     | BULON FIJACION     |                            |     |
| 19       | 213 3560 | 1          | DICHTRING          | WASHER            | BAGUE D ETANCHEITE | ANILLO DE JUNTA    |                            | 01  |
| 20       | 213 3561 | 1          | ABLASSSCHRAUBE     | DRAIN PLUG        | VIS DE VIDANGE     | TORN.VACIADO       |                            |     |

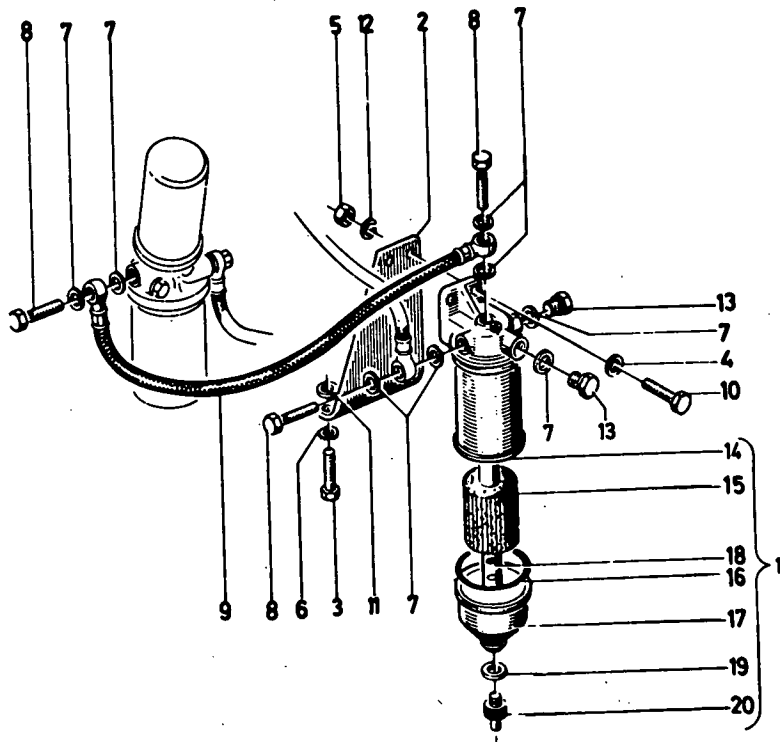

1003-42 500 6400

| Bild-Nr. | Teil-Nr. | Stück-Zahl | Deutsch            | English           | Français            | Español            | Nummer/Bemerkung        | ETK |
|----------|----------|------------|--------------------|-------------------|---------------------|--------------------|-------------------------|-----|
| 1        | 233 2632 | 1          | KRAFTSTOFFFILTER   | FUEL FILTER       | FILTRE A COMBUST    | FILTRO COMBUSTIBLE |                         |     |
| 2        | 237 6749 | 1          | HALTER             | RETAINER          | SUPPORT/PORTE-OUTIL | SOPORTE            |                         |     |
| 3        | 111 1136 | 2          | SECHSKANTSCHRAUBE  | HEX-BOLT          | VIS 6 PANS          | TORNILLO HEXAGONAL | M 8X35 DIN 933-8-8-A4C  |     |
| 4        | 110 7101 | 2          | SCHEIBE            | DISC/PANE/PLATE   | RONDELLE/DISQUE     | DISCO              | 8.4 DIN 125-A4C         |     |
| 5        | 111 2824 | 2          | SECHSKANTMUTTER    | HEX-NUT           | ECROU 6 PANS        | TUERCA HEXAGONAL   | M8 DIN 934-M8-A4C       |     |
| 6        | 110 1492 | 2          | ZAHNSCHEIBE        | TOOTHED WASHER    | RONDELLE DENTEE     | ARANDELA DENTADA   | A 8.2DIN 6797 VZKC      |     |
| 7        | 111 8688 | 4          | DICHTRING          | WASHER            | BAGUE D ETANCHEITE  | ANILLO DE JUNTA    | A 14 X 18 DIN 7603-CU   |     |
| 8        | 111 9246 | 2          | HOHLSCHRAUBE       | BANJO BOLT        | VIS BANJO           | TORNILLO RACOR     | A 8 DIN 7623            |     |
| 9        | 126 6161 | 1          | SCHLAUCHLEITUNG    | HOSE              | CONDUITE FLEXIBLE   | MANGUERA           | 08734-80-03-170         | 01  |
| 10       | 111 2341 | 2          | SECHSKANTSCHRAUBE  | HEX-BOLT          | VIS 6 PANS          | TORNILLO HEXAGONAL | M 8X33 DIN 933-M8-8-A4C |     |
| 11       | 121 6143 | 2          | RING               | RING              | BAGUE/ANNEAU        | ANILLO             | 2 329 B 1               |     |
| 12       | 110 2799 | 2          | FEDERRING          | SPRING LOCKWASHER | RONDELLE GROVER     | ARANDELA ELASTICA  | A 8 DIN 128 A4C         |     |
| 13       | 111 8963 | 2          | VERSCHLUSSSCHRAUBE | SCREW PLUG        | BOUCHON FILETE      | TAPON ROSCADO      | M14X1.5 DIN 7604-A4C    |     |
| 14       | 233 0283 | 1          | FLANSCH            | FLANGE            | BRIDE/COLLET        | BRIDA              |                         |     |
| 15       | 213 3558 | 1          | FILTEREINSATZ      | ELEMENT           | CART-FILTRANTE      | ELEMENTO FILTRO    |                         | 01  |
| 16       | 213 3562 | 1          | DICHTRING          | WASHER            | BAGUE D ETANCHEITE  | ANILLO DE JUNTA    |                         | 01  |
| 17       | 213 3557 | 1          | WASSERBEHAELTER    | WATER RESERVOIR   | RESERVOIR D EAU     | RECIPIENTE AGUA    |                         |     |
| 18       | 213 3559 | 1          | SPANNSCHRAUBE      | CLAMPING BOLT     | VIS DE TENSION      | TORNILLO FIJAC.    |                         |     |
| 19       | 213 3560 | 1          | DICHTRING          | WASHER            | BAGUE D ETANCHEITE  | ANILLO DE JUNTA    |                         | 01  |
| 20       | 213 3561 | 1          | ABLASSSCHRAUBE     | DRAIN PLUG        | VIS DE VIDANGE      | TORN-VACIADO       |                         |     |



TROCKENLUFTFILTER  
 DRY-TYPE AIR CLEANER  
 EPURATEUR D AIR DU TYPE SEC  
 FILTRO DE AIRE EN SECO

030 90 38 606

7876/5843  
 7868/0357

1003-43 500 4293

D-4506

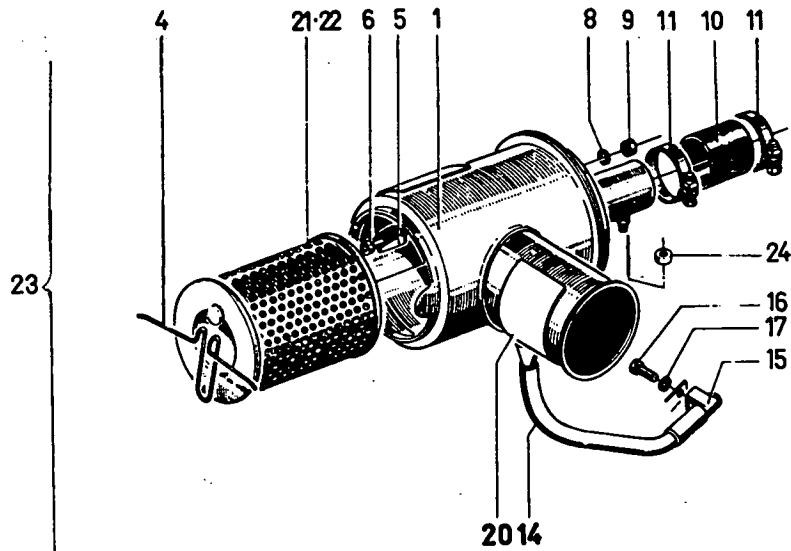

1003-43 500 4293

| Bild Nr. | Teile-Nr. | Stück-Zahl | Deutsch           | English           | Français           | Español            | Nummer/Bemerkung          | ETK |
|----------|-----------|------------|-------------------|-------------------|--------------------|--------------------|---------------------------|-----|
| 1        | 232 5635  | 1          | FILTERGEHÄUSE     | BODY              | CORPS DE FILTRE    | CAJA FILTRO        |                           |     |
| 4        | 231 5897  | 1          | KNEBEL            | TORNY BAR/HANDLE  | GARROT             | MULETILLA          |                           |     |
| 5        | 232 2921  | 3          | FÜHRUNGSBUEGEL    | GUIDE             | ETRIER DE GUIDAGE  | ESTRIBO GUIA       |                           |     |
| 6        | 110 2193  | 3          | ZYLINDERSCHRAUBE  | CHEESE-HEAD SCREW | VIS TETE CYLINDR.  | TORN-CEZA-CILIND.  | M 8 X 15 DIN 913- 8-8 A9C |     |
| 8        | 116 9689  | 3          | SICHERUNGSSCHEIBE | LOCKING WASHER    | RONDELLE SECURITE  | ARANDELA SEGURIDAD | 8 M 2203                  |     |
| 9        | 111 2824  | 3          | SECHSKANTMUTTER   | HEX-NUT           | ECROU 6 PANS       | TUERCA HEXAGONAL   | M 8 DIN 934-M 8 A9C       |     |
| 10       | 112 1627  | 1          | GUMMISCHLAUCH     | RUBBER HOSE       | FLEXIBLE CAOUTCH   | MANGUERA CAUCHO    | 70X 55DIN73411            | 01  |
| 11       | 116 6917  | 2          | SCHLAUCHSCHELLE   | HOSE CLIP         | COLLIER SERRAGE    | ABRAZADERA MANGUER | S 80X15 M 735             |     |
| 14       | 231 5967  | 1          | PVC-SCHLAUCH      | PVC HOSE          | FLEXIBLE EN PVC    | MANGUERA PVC       |                           |     |
| 15       | 231 5968  | 1          | MUNDSTUECK        | MOUTHPIECE        | BEC/EMBOUCHURE     | BOQUILLA           |                           |     |
| 16       | 112 3746  | 1          | SECHSKANTSCHRAUBE | HEX-BOLT          | VIS 6 PANS         | TORNILLO HEXAGONAL | M 5X 10 DIN 933- 8-8-A9C  |     |
| 17       | 116 7193  | 1          | SICHERUNGSSCHEIBE | LOCKING WASHER    | RONDELLE SECURITE  | ARANDELA SEGURIDAD | 5 M 2203                  |     |
| 20       | 121 1590  | 1          | BEDIENUNGSSCHILD  | INSTRUCTION PLATE | PLAQUE INSTRUCTNS  | ROTULO SERVICIO    | 4 308 A 656               |     |
| 21       | 233 9812  | 1          | FILTERPATRONE     | CARTRIDGE         | CARTOUCHE FILTRANT | CARTUCHO FILTRO    |                           | 01  |
| 22       | 233 9813  | 1          | FILTERPATRONE     | CARTRIDGE         | CARTOUCHE FILTRANT | CARTUCHO FILTRO    | 8355-WAHLWEISE POS-22     | 01  |
| 23       | 232 5729  | 1          | LUFTFILTER        | AIR CLEANER       | FILTRE A AIR       | FILTRO AIRE        | 8355-WAHLWEISE POS-21     |     |
| 24       | 237 8947  | 1          | VERSCHLUSSMUTTER  | CAP NUT           | ECROU BORGNE       | TUERCA DE CIERRE   |                           |     |

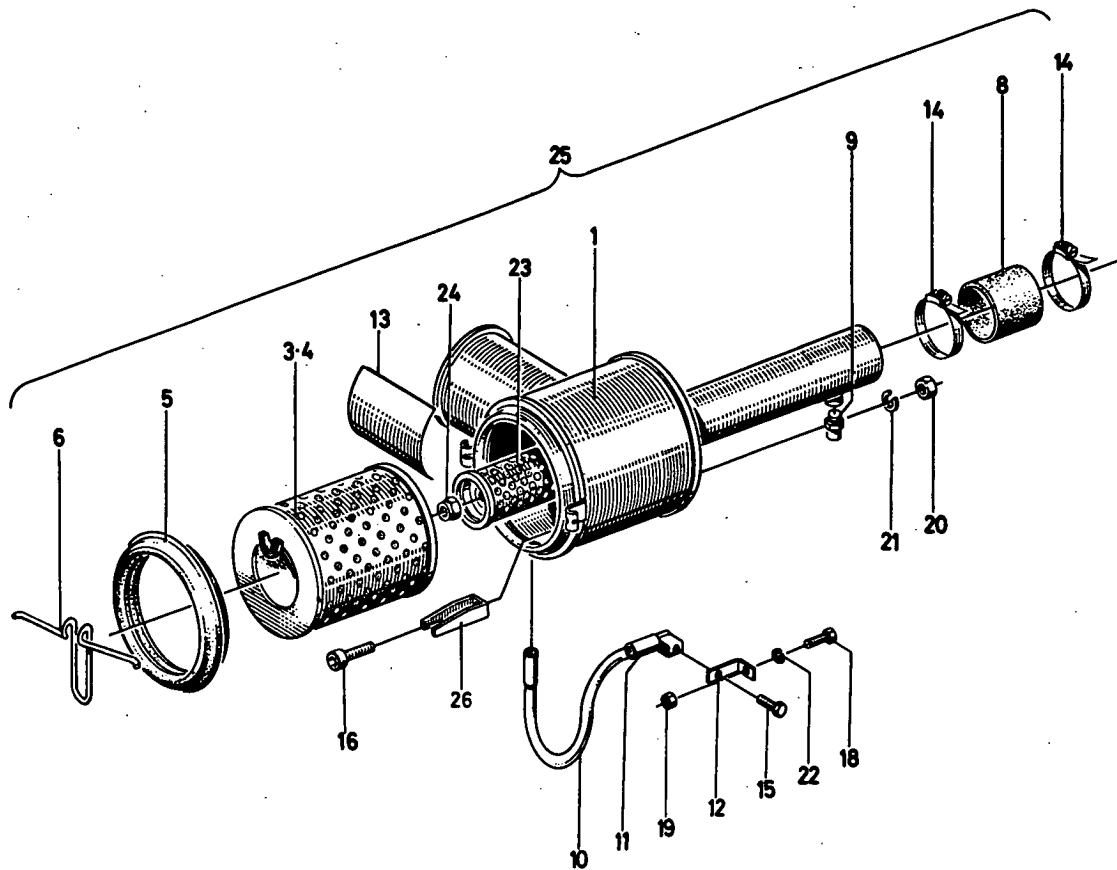

| BNr. Nr. | Teil-Nr. | Stück-Zahl | Deutsch            | English           | Français           | Español            | Number/Bemerkung                           | ETK |
|----------|----------|------------|--------------------|-------------------|--------------------|--------------------|--|-----|
| 1        | 237 4938 | 1          | FILTERGEHÄUSE      | BODY              | CORPS DE FILTRE    | CAJA FILTRO        |  |     |
| 3        | 233 9832 | 1          | FILTERPATRONE      | CARTRIDGE         | CARTOUCHE FILTRANT | CARTUCHO FILTRO    | B355-WAHLWEISE POS.4                       | 01  |
| 4        | 233 9833 | 1          | FILTERPATRONE      | CARTRIDGE         | CARTOUCHE FILTRANT | CARTUCHO FILTRO    | B355-WAHLWEISE POS.3                       | 01  |
| 5        | 237 2778 | 1          | DICHTUNG           | GASKET            | GARNITURE/JOINT    | JUNTA              |  | 01  |
| 6        | 237 4876 | 1          | FEDERNEBEL         | CLIP              | POIGNEE A RESSORT  | MULETILLA RESORTE  |  |     |
| 8        | 136 5397 | 1          | GUMMIRUFPE         | RUBBER SLEEVE     | MANCHON CAOUTCHOUC | MANGUITO CAUCHO    | A 70X 80X 65H 650                          | 01  |
| 9        | 113 0598 | 1          | VERSCHLUSSMUTTER   | CAP NUT           | ECROU BORGNE       | TUERCA DE CIERRE   | M10X3 DIN 7605 A4C                         |     |
| 10       | 231 5967 | 1          | PVC-SCHLAUCH       | PVC HOSE          | FLEXIBLE EN PVC    | MANGUERA PVC       |  |     |
| 11       | 231 5968 | 1          | MUNDSTUECK         | MOUTHPIECE        | BECC/EMBOUTURE     | BOQUILLA           |  |     |
| 12       | 237 4923 | 1          | HALTER             | RETAINER          | SUPPORT/PORTEOUTIL | SOPORTE            |  |     |
| 13       | 121 1570 | 1          | BEDIENUNGSSCHILD   | INSTRUCTION PLATE | PLAQUE INSTRUCTNS  | ROTULO SERVICIO    | 4 308 A 656                                |     |
| 14       | 136 6437 | 2          | SCHLAUCHSCHELLE    | HOSE CLIP         | COLLIER SERRAGE    | ABRAZADERA MANGUER | S 80 X15 H 735                             |     |
| 15       | 111 2201 | 1          | SECHSKANTSCHRAUBE  | HEX-BOLT          | VIS 6 PANS         | TORNILLO HEXAGONAL | M 5X 12 DIN 933- 8-8-A4C                   |     |
| 16       | 110 2193 | 3          | ZYLINDERSCHRAUBE   | CHEESE-HEAD SCREW | VIS TETE CYLINDR.  | TORN-CEZA-CILIND-  | M 8X 16 DIN 932- 8-8-A4C                   |     |
| 18       | 111 2258 | 1          | SECHSKANTSCHRAUBE  | HEX-BOLT          | VIS 6 PANS         | TORNILLO HEXAGONAL | M 6X 18 DIN 933- 8-8-A4C                   |     |
| 17       | 111 2833 | 1          | SECHSKANTMUTTER    | HEX-NUT           | ECROU 6 PANS       | TUERCA HEXAGONAL   | M 6 DIN 934-M 8 A4C                        |     |
| 20       | 111 2829 | 3          | SECHSKANTMUTTER    | HEX-NUT           | ECROU 6 PANS       | TUERCA HEXAGONAL   | M 8 DIN 934-M 8 A4C                        |     |
| 21       | 110 2799 | 2          | FEDERRING          | SPRING LOCKWASHER | RONDELLE GROMER    | ARANDELA ELASTICA  | A 8 DIN 128 A4C                            |     |
| 22       | 110 2797 | 1          | FEDERRING          | SPRING LOCKWASHER | RONDELLE GROMER    | ARANDELA ELASTICA  | A 6 DIN 128 A4C                            |     |
| 23       | 237 9161 | 1          | SICHERHEITSPATRONE | SAFETY CARTRIDGE  | CARTOUCHE SECURITE | CARTUCHO SEGURIDAD | B233-NUR MIT TN 1003-43-500 4295 VERWENDEN |     |
| 24       | 116 7153 | 1          | SECHSKANTMUTTER    | HEX-NUT           | ECROU 6 PANS       | TUERCA HEXAGONAL   | M8H 2125                                   |     |
| 25       | 237 4915 | 1          | TROCKENLUFTFILTER  | FILTER            | FILTRE SEC         | FILTRO SECO        |  |     |
| 26       | 236 6503 | 3          | FUEHRUNGSBUEGEL    | GUIDE             | ETRIER DE GUIDAGE  | ESTRIBO GUIA       |  |     |

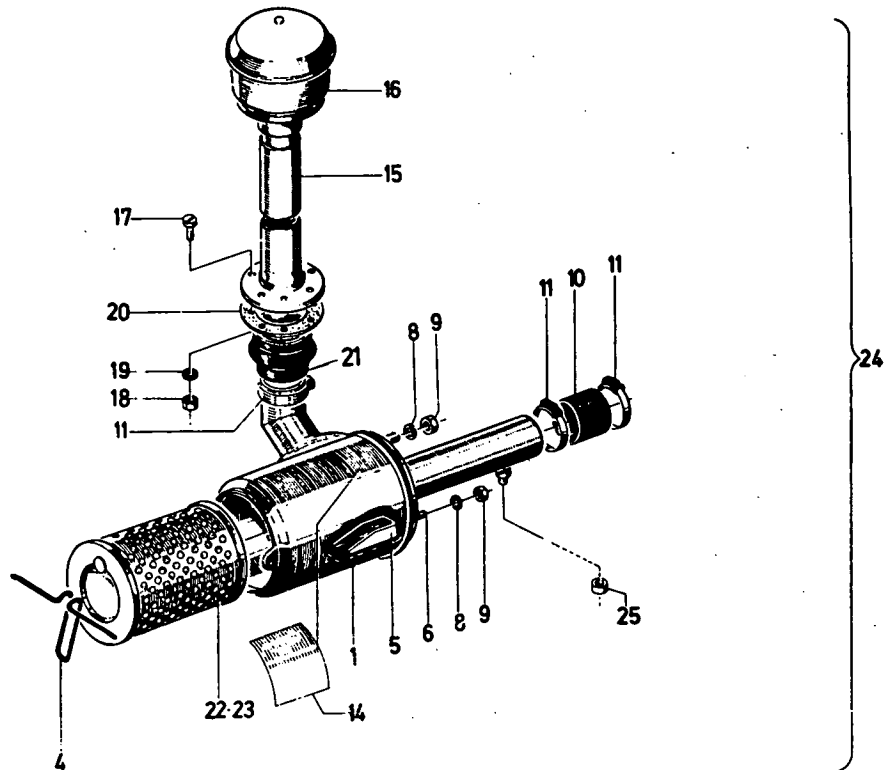

1003-43 500 4294

| Bld Nr. | Teil-Nr. | Stück-Zahl | Deutsch          | English           | Français           | Español            | Nummer/Bemerkung         | ETK |
|---------|----------|------------|------------------|-------------------|--------------------|--------------------|--------------------------|-----|
| 1       | 232 5984 | 1          | FILTERGEHÄUSE    | BODY              | CORPS DE FILTRE    | CAJA FILTRO        |                          |     |
| 4       | 231 5857 | 1          | KNEBEL           | TOMMY BAR/HANDLE  | GARROT             | MULETILLA          |                          |     |
| 5       | 232 2921 | 3          | FÜHRUNGSBUEGEL   | GUIDE             | ETRIER DE GUIDAGE  | ESTRIBO GUIA       |                          |     |
| 6       | 110 2148 | 3          | ZYLINDERSCHRAUBE | CHEESE-HEAD SCREW | VIS TETE CYLINDR.  | TORN-CAZA-CILIND.  | M 8 X 15DIN 912- 8-8 A4C |     |
| 8       | 110 2799 | 3          | FEDERRING        | SPRING LOCKWASHER | RONDELLE GROWER    | ARANDELA ELASTICA  | A 6 DIN 128 A4C          |     |
| 9       | 111 2824 | 3          | SECHSKANTMUTTER  | HEX-NUT           | ECROU 6 PANS       | TUERCA HEXAGONAL   | M 8 DIN 934-M 8 A4C      |     |
| 10      | 112 1627 | 1          | GUMMISCHLAUCH    | RUBBER HOSE       | FLEXIBLE CAOUTCH   | MANGUERA CAUCHO    | 70X 55DIN73433           | 01  |
| 11      | 116 6417 | 3          | SCHLAUCHSCHELLE  | HOSE CLIP         | COLLIER SERRAGE    | ABRAZADERA MANGUER | S 80X15 H 735            |     |
| 14      | 121 1590 | 1          | BEDIENUNGSSCHILD | INSTRUCTION PLATE | PLAQUE INSTRUCTNS  | ROTULO SERVICIO    | 4 308 A 656              |     |
| 15      | 232 6051 | 1          | ANSAUGROHR       | INTAKE PIPE       | TUYAU ASPIRATION   | TUBO ASPIRACION    |                          |     |
| 16      | 231 5451 | 1          | VORFILTER        | PREFILTER/CLEANER | PREFILTRE          | PRE-FILTRO         |                          |     |
| 17      | 110 5537 | 6          | ZYLINDERSCHRAUBE | CHEESE-HEAD SCREW | VIS TETE CYLINDR.  | TORN-CAZA-CILIND.  | M 6 X 15DIN 84- 4-8-A4C  |     |
| 18      | 111 2813 | 6          | SECHSKANTMUTTER  | HEX-NUT           | ECROU 6 PANS       | TUERCA HEXAGONAL   | M 6 DIN 934-M 6 A4C      |     |
| 19      | 110 2797 | 6          | FEDERRING        | SPRING LOCKWASHER | RONDELLE GROWER    | ARANDELA ELASTICA  | A 6 DIN 128 A4C          |     |
| 20      | 231 9508 | 1          | DICHTUNG         | GASKET            | GARNITURE/JOINT    | JUNTA              |                          | 01  |
| 21      | 231 6032 | 1          | HANSCHETTE       | SEAL/SLEEVE       | EMBOUTI/GARNITURE  | MANGUITO           |                          | 01  |
| 22      | 233 9812 | 1          | FILTERPATRONE    | CARTRIDGE         | CARTOUCHE FILTRANT | CARTUCHO FILTRO    | 8355-WAHLWEISE POS-23    | 01  |
| 23      | 233 9813 | 1          | FILTERPATRONE    | CARTRIDGE         | CARTOUCHE FILTRANT | CARTUCHO FILTRO    | 8355-WAHLWEISE POS-22    | 01  |
| 24      | 232 5981 | 1          | LUFTFILTER       | AIR CLEANER       | FILTRE A AIR       | FILTRO AIRE        |                          |     |
| 25      | 237 8447 | 1          | VERSCHLUSSMUTTER | CAP NUT           | ECROU BORGNE       | TUERCA DE CIERRE   |                          |     |

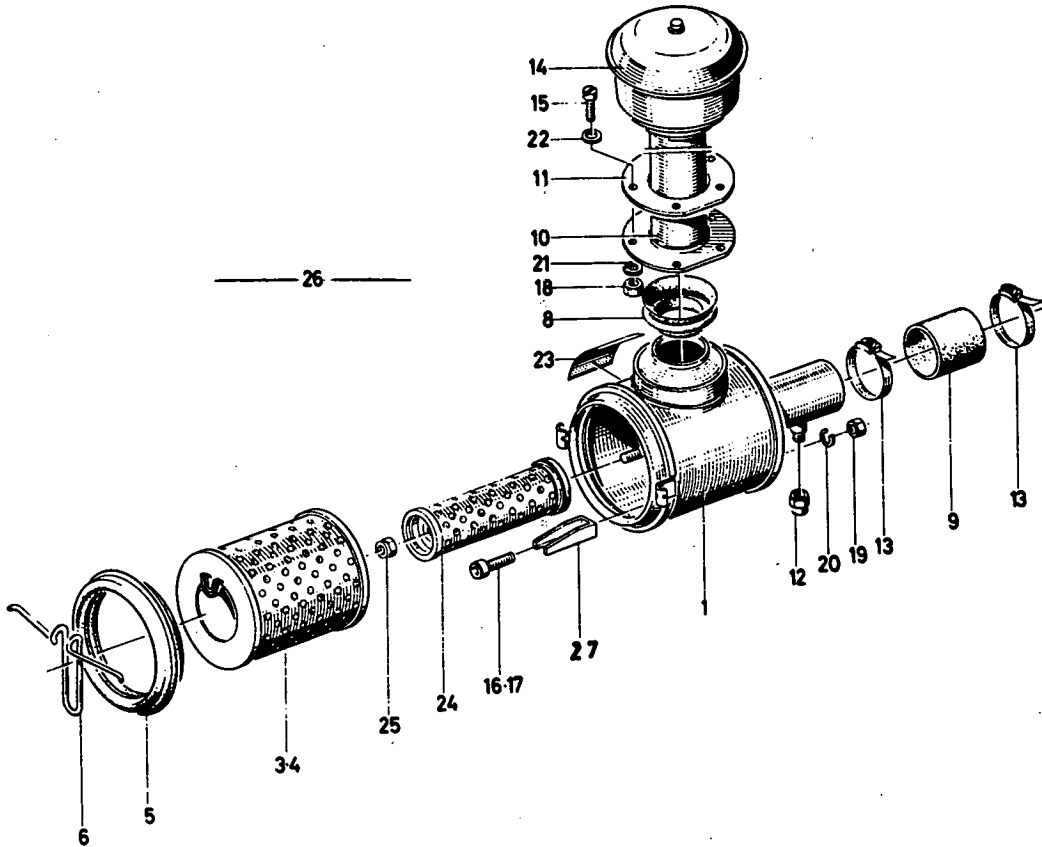

1003-43 500 6422

| Bild Nr. | Teil-Nr. | Stück-Zahl | Deutsch            | English           | Français           | Español            | Nummer/Bemerkung                            | ETK |
|----------|----------|------------|--------------------|-------------------|--------------------|--------------------|---|-----|
| 1        | 237 4903 | 1          | FILTERGEHÄUSE      | BODY              | CORPS DE FILTRE    | CAJA FILTRO        |   |     |
| 3        | 233 7812 | 1          | FILTERPATRONE      | CARTRIDGE         | CARTOUCHE FILTRANT | CARTUCHO FILTRO    | B355-WAHLWEISE POS.4                        | 01  |
| 4        | 233 7813 | 1          | FILTERPATRONE      | CARTRIDGE         | CARTOUCHE FILTRANT | CARTUCHO FILTRO    | B355-WAHLWEISE POS.3                        | 01  |
| 5        | 237 2778 | 1          | DICHRING           | WASHER            | BAGUE D'ÉTANCHEITE | ANILLO DE JUNTA    |   | 01  |
| 6        | 237 4676 | 1          | FEDERKNIEBEL       | CLIP              | POIGNEE A RESSORT  | MULETILLA RESORTE  |   | 01  |
| 8        | 237 4909 | 1          | HANSCHETTE         | SEAL/SLEEVE       | EMBOUTI/GARNITURE  | MANGUITO           |   | 01  |
| 9        | 116 5397 | 1          | GUMMIRUFFE         | RUBBER SLEEVE     | MANCHON CAOUTCHOUC | MANGUITO CAUCHO    | A 70X 80X 6,5H 6,50                         | 01  |
| 10       | 237 9157 | 1          | ANSAUGROHR         | INTAKE PIPE       | TUYAU ASPIRATION   | TUBO ASPIRACION    |   |     |
| 11       | 237 0851 | 1          | FLANSCH            | FLANGE            | BRIDE/COLLET       | BRIDA              |   |     |
| 12       | 113 0598 | 1          | VERSCHLUSSMUTTER   | CAP NUT           | ECROU BORGNE       | TUERCA DE CIERRE   | M 10X1 DIN 7605 A9C 4C                      |     |
| 13       | 116 6417 | 2          | SCHLAUSCHELLE      | HOSE CLIP         | COLLIER SERRAGE    | ABRAZADERA MANGUER | S 80X15H 735                                |     |
| 14       | 231 5451 | 1          | VORFILTER          | PREFILTER/CLEANER | PREFILTRE          | PRE-FILTRO         |   |     |
| 15       | 110 5537 | 6          | ZYLINDERSCHRAUBE   | CHEESE-HEAD SCREW | VIS TETE CYLINDR.  | TORN-CBZA-CILIND.  | M6X15 DIN 84-4-8-A9C                        |     |
| 16       | 110 2193 | 2          | ZYLINDERSCHRAUBE   | CHEESE-HEAD SCREW | VIS TETE CYLINDR.  | TORN-CBZA-CILIND.  | M8X15 DIN 912-8-8-A9C                       |     |
| 17       | 112 3699 | 1          | ZYLINDERSCHRAUBE   | CHEESE-HEAD SCREW | VIS TETE CYLINDR.  | TORN-CBZA-CILIND.  | M 8X30 DIN 912-8-8 A9C                      |     |
| 18       | 113 2813 | 6          | SECHSKANTMUTTER    | HEX-NUT           | ECROU 6 PANS       | TUERCA HEXAGONAL   | M 6 DIN 934-M8-A9C                          |     |
| 19       | 113 2824 | 3          | SECHSKANTMUTTER    | HEX-NUT           | ECROU 6 PANS       | TUERCA HEXAGONAL   | M8 DIN 934-M8-A9C                           |     |
| 20       | 110 2799 | 3          | FEDERRING          | SPRING LOCKWASHER | RONDELLE GROMER    | ARANDELA ELASTICA  | A 8 DIN 128 A9C                             |     |
| 21       | 110 2797 | 6          | FEDERRING          | SPRING LOCKWASHER | RONDELLE GROMER    | ARANDELA ELASTICA  | A 6 DIN 128 A9C                             |     |
| 22       | 110 7095 | 12         | SCHEIBE            | DISC/PANE/PLATE   | RONDELLE/DISQUE    | DISCO              | 6,4 DIN 125-ST-A9C                          |     |
| 23       | 121 1590 | 1          | BEDIENUNGSSCHILD   | INSTRUCTION PLATE | PLAQUE INSTRUCTYNS | ROTULO SERVICIO    | 4 308 A 656                                 |     |
| 24       | 237 9161 | 1          | SICHERHEITSPATRONE | SAFETY CARTRIDGE  | CARTOUCHE SECURITE | CARTUCHO SEGURIDAD | B233-NUR MIT TN 1001-43-500 9295 VERWENDEN. |     |
| 25       | 116 7153 | 1          | SECHSKANTMUTTER    | HEX-NUT           | ECROU 6 PANS       | TUERCA HEXAGONAL   | M8H 2125                                    |     |
| 26       | 237 5057 | 1          | LUFTFILTER         | AIR CLEANER       | FILTRE A AIR       | FILTRO AIRE        |   |     |
| 27       | 238 6503 | 3          | FUEHRUNGSBUEGEL    | GUIDE             | ETRIER DE GUIDAGE  | ESTRIBO GUIA       |   |     |



ÖLBADLUFTFILTER  
OIL BATH AIR CLEANER  
EPURATEUR D AIR A BAIN D HUILE  
FILTRO DE AIRE EN BANO DE ACEITE

1003-435004225

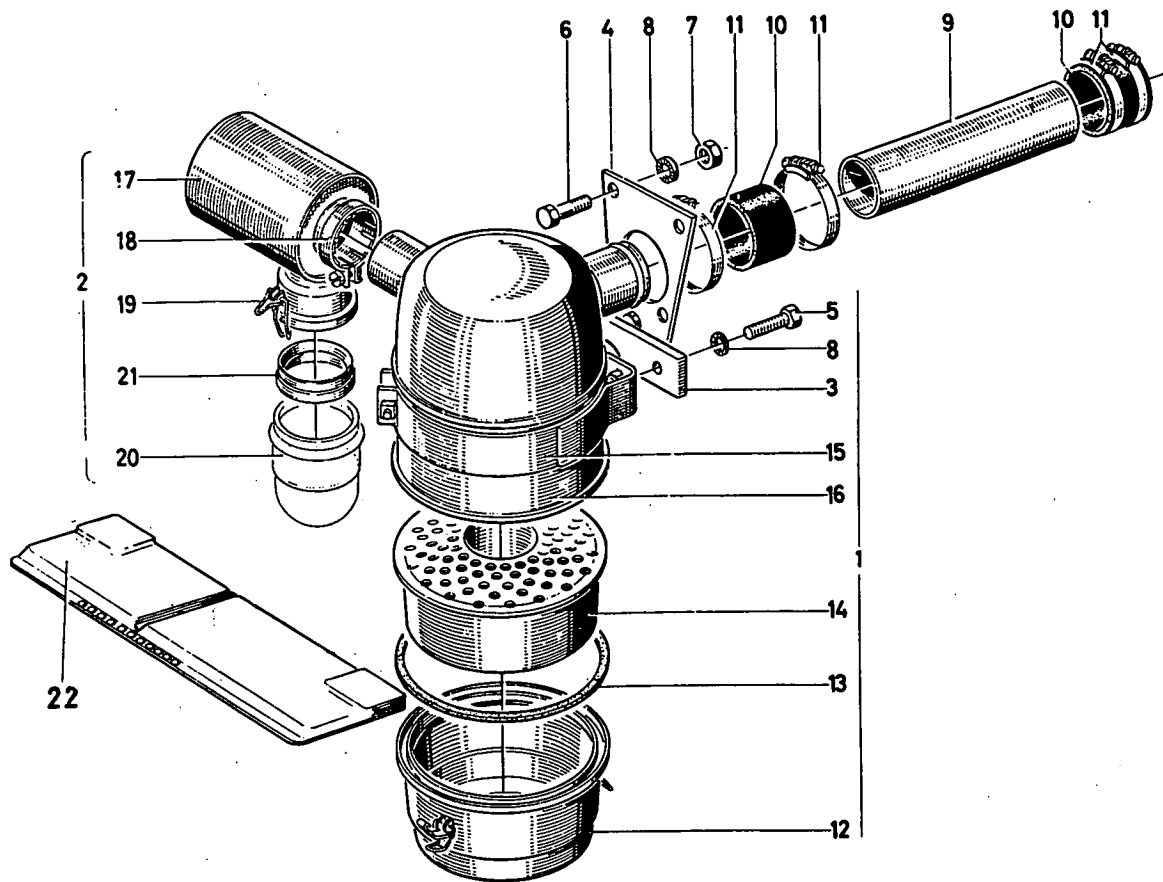

1003-43 500 4225

| Stk-Nr. | Teil-Nr. | Stück-Zahl | Deutsch           | English          | Français            | Español            | Nummer/Bemerkung          | ETK |
|---------|----------|------------|-------------------|------------------|---------------------|--------------------|---------------------------|-----|
| 1       | 210 2238 | 1          | ÖLBADLUFTFILTER   | BATH AIR CLEANER | EPUR AIR BAIN HUILE | FILT-AIR BANOACEIT | 0150-22-425-10            |     |
| 2       | 216 8564 | 1          | ABSCHIEDER        | SEPARATOR        | SEPARATEUR          | SEPARADOR          |                           |     |
| 3       | 233 3237 | 1          | ANSCHLUSSSTUECK   | CONNECTOR        | PIECE DE RACCORDEM  | PZA-LIGACION       |                           |     |
| 4       | 233 3242 | 1          | FILTERTRAEGER     | SUPPORT          | SUPPORT DE FILTRE   | PORTA-FILTRO       |                           |     |
| 5       | 111 2322 | 2          | SECHSKANTSCHRAUBE | HEX-BOLT         | VIS 6 PANS          | TORNILLO HEXAGONAL | M 8 X 20 DIN 933- A-A-ANC |     |
| 6       | 111 2305 | 2          | SECHSKANTSCHRAUBE | HEX-BOLT         | VIS 6 PANS          | TORNILLO HEXAGONAL | M 8 X 15 DIN 933- A-A-ANC |     |
| 7       | 111 2824 | 3          | SECHSKANMUTTER    | HEX-NUT          | ECROU 6 PANS        | TUERCA HEXAGONAL   | M 8 DIN 934-M 8 ANC       |     |
| 8       | 116 7687 | 5          | SICHERUNGSSCHEIBE | LOCKING WASHER   | RONDILLE SECURITE   | ARANDELA SEGURIDAD | 8 H 2203                  |     |
| 9       | 233 3248 | 1          | ROHR              | PIPE/TUBE        | TUBE/TUYAU          | TUBO               |                           |     |
| 10      | 112 1627 | 2          | GUMMISCHLAUCH     | RUBBER HOSE      | FLEXIBLE CAOUTCH    | MANGUERA CAUCHO    | 70X 55DIN73411            | 01  |
| 11      | 116 6417 | 4          | SCHLAUCHSCHELLE   | HOSE CLIP        | COLLIER SERRAGE     | ABRAZADERA MANGUER | S 80X15 H 735             |     |
| 12      | 210 2528 | 1          | ÖLBEBÄLTER        | OIL RESERVOIR    | RESERVOIR D HUILE   | TANQUE ACEITE      | 0150-22-425-01            |     |
| 13      | 210 2527 | 1          | DICHRING          | WASHER           | BAGUE D ETANCHEITE  | ANILLO DE JUNTA    | 0150-22-425-02            | 01  |
| 14      | 210 2530 | 1          | FILTEREINSATZ     | ELEMENT          | CART-FILTRANTE      | ELEMENTO FILTRO    | 0150-22-425-03            |     |
| 15      | 210 2531 | 1          | HALTER            | RETAINER         | SUPPORT/PORTEOUTIL  | SOPORTE            | 0150-22-425-04            |     |
| 16      | 210 2532 | 1P         | FILTEROBERTEIL    | TOP              | PART-SUP-DE FILTRE  | PTE-SUPER-FILTRO   | 0150-22-425-05            |     |
| 17      | 210 2536 | 1P         | GEHÄUSE           | HOUSING/CASE     | CARTER/BOITIER      | CAJA/BLOQUE/CUERPO |                           |     |
| 18      | 336 3511 | 1          | ROHRSCHELLE       | PIPE CLIP        | COLLIER PR TUBES    | ABRAZADERA DE TUBO | 0150-22-17-02             |     |
| 19      | 336 3502 | 2          | VERSCHLUSS        | FASTENER/LOCK    | FERMETURE           | CIERRE             | 0150-22-07-06             |     |
| 20      | 336 3503 | 1          | STAUBSAMMELTOPF   | DUST TRAP        | POT COLLECT POUSS   | COPA COLECT.POLVO  | 0150-22-07-07             | 01  |
| 21      | 336 3505 | 1          | TRICHTER          | TUNDISH/FUNNEL   | ENTONNOIR/TROMPET.  | ENBUDO             | 0150-22-07-11             | 01  |
| 22      | 336 8242 | 1          | BATTERIEABDECKUNG | BATTERY COVER    | RECOUVR BATTERIE    | CUBRE-BATERIA      | 1126-44-01-05             |     |

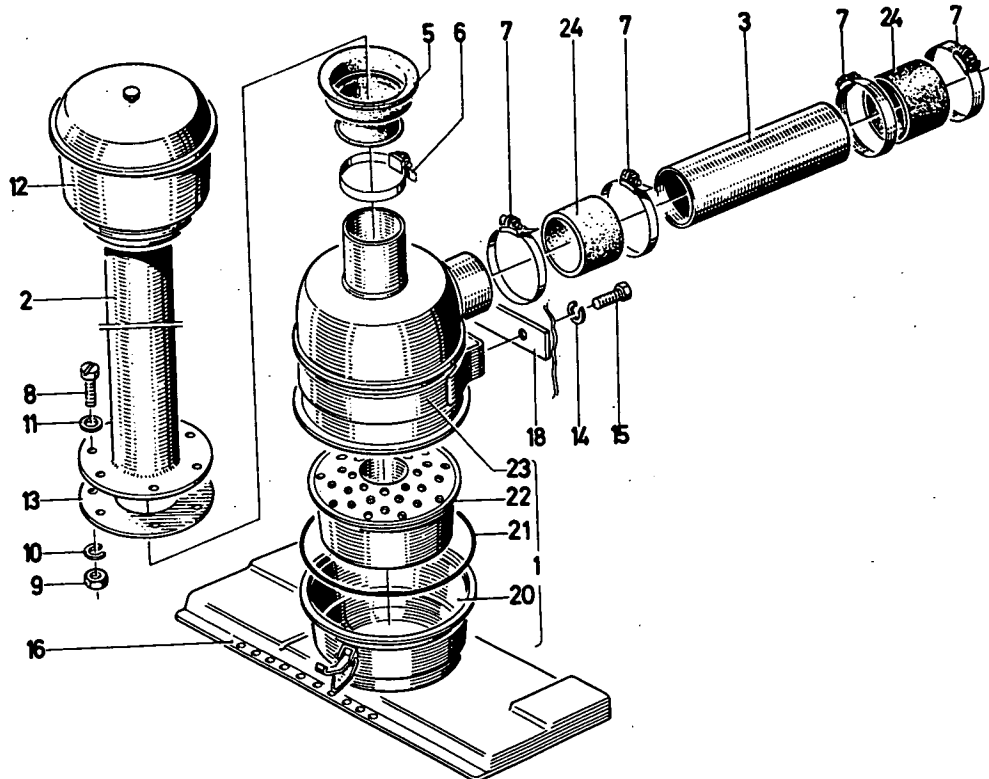

1003-43 500 6118

| Bild Nr. | Teil-Nr. | Stück-Zahl | Deutsch           | English           | Français           | Español            | Nummer/Bemerkung          | ETK |
|----------|----------|------------|-------------------|-------------------|--------------------|--------------------|---------------------------|-----|
| 1        | 210 2239 | 1          | ÖLROHR            | OIL PIPE          | TUYAU D HUILE      | TUBO ACEITE        | 0150-22-425-20            |     |
| 2        | 237 9157 | 1          | ANSAUGROHR        | INTAKE PIPE       | TUYAU ASPIRATION   | TUBO ASPIRACION    |                           |     |
| 3        | 140 0680 | 1          | ROHR              | PIPE/TUBE         | TUBE/TUYAU         | TUBO               | 70X1X139 DIN 2393 SST2NBK |     |
| 5        | 233 8083 | 1          | MANSCHE           | SEAL/SLEEVE       | EMBOUTI/GARNITURE  | MANGUITO           |                           | 01  |
| 6        | 116 6407 | 1          | SCHLAUCHSCHELLE   | HOSE CLIP         | COLLIER SERRAGE    | ABRAZADERA MANGUER | S 74X15 H 735             |     |
| 7        | 116 6417 | 4          | SCHLAUCHSCHELLE   | HOSE CLIP         | COLLIER SERRAGE    | ABRAZADERA MANGUER | S 80X15H 735              |     |
| 8        | 110 5537 | 6          | ZYLINDERSCHRAUBE  | CHEESE-HEAD SCREW | VIS TETE CYLINDR.  | TORN-CBZA-CILIND.  | AM6X15 DIN 84-4-8-A4C     |     |
| 9        | 111 2813 | 6          | SECHSKANTMUTTER   | HEX-NUT           | ECROU 6 PANS       | TUERCA HEXAGONAL   | M 6 DIN 934-M8-A4C        |     |
| 10       | 110 2797 | 6          | FEDERRING         | SPRING LOCKWASHER | RONDELLE GROVER    | ARANDELA ELASTICA  | A 6 DIN 128 A4C           |     |
| 11       | 110 7095 | 12         | SCHEIBE           | DISC/PANE/PLATE   | RONDELLE/DISQUE    | DISCO              | 6.4 DIN 125-ST-A4C        |     |
| 12       | 231 5451 | 1          | VORFILTER         | PREFILTER/CLEANER | PREFILTRE          | PRE-FILTRO         |                           |     |
| 13       | 237 0851 | 1          | FLANSCH           | FLANGE            | BRIDE/COLLET       | BRIDA              |                           |     |
| 14       | 110 2799 | 2          | FEDERRING         | SPRING LOCKWASHER | RONDELLE GROVER    | ARANDELA ELASTICA  | A 8 DIN 128 A4C           |     |
| 15       | 111 2322 | 2          | SECHSKANTSCHRAUBE | HEX-BOLT          | VIS 6 PANS         | TORNILLO HEXAGONAL | M 8X23 DIN 933-M 8.8 A4C  |     |
| 16       | 338 8292 | Z 1        | BATTERIEABDECKUNG | BATTERY COVER     | RECOUVR BATTERIE   | CUBRE-BATERIA      | 1126-49-01-05             |     |
| 18       | 237 0852 | 1          | ZWISCHENSTUECK    | ADAPTER           | PIECE INTERCALAIRE | PIEZA INTERMEDIA   |                           |     |
| 20       | 210 2528 | 1          | ÖLBEHALTER        | OIL RESERVOIR     | RESERVOIR D HUILE  | TANQUE ACEITE      | 0150-22-425-01            |     |
| 21       | 210 2529 | 1          | DICHTUNG          | GASKET            | GARNITURE/JOINT    | JUNTA              | 0150-22-425-02            | 01  |
| 22       | 210 2530 | 1          | FILTEREINSATZ     | ELEMENT           | CART-FILTRANTE     | ELEMENTO FILTRO    | 0150-22-425-03            |     |
| 23       | 210 2531 | 1          | HALTER            | RETAINER          | SUPPORT/PORTEQUIL  | SOPORTE            | 0150-22-425-04            |     |
| 24       | 116 5397 | 2          | GUMMIHUFFE        | RUBBER SLEEVE     | MANCHON CAOUTCHOUC | MANGUITO CAUCHO    | A 70X 80X 65H 650         | 01  |



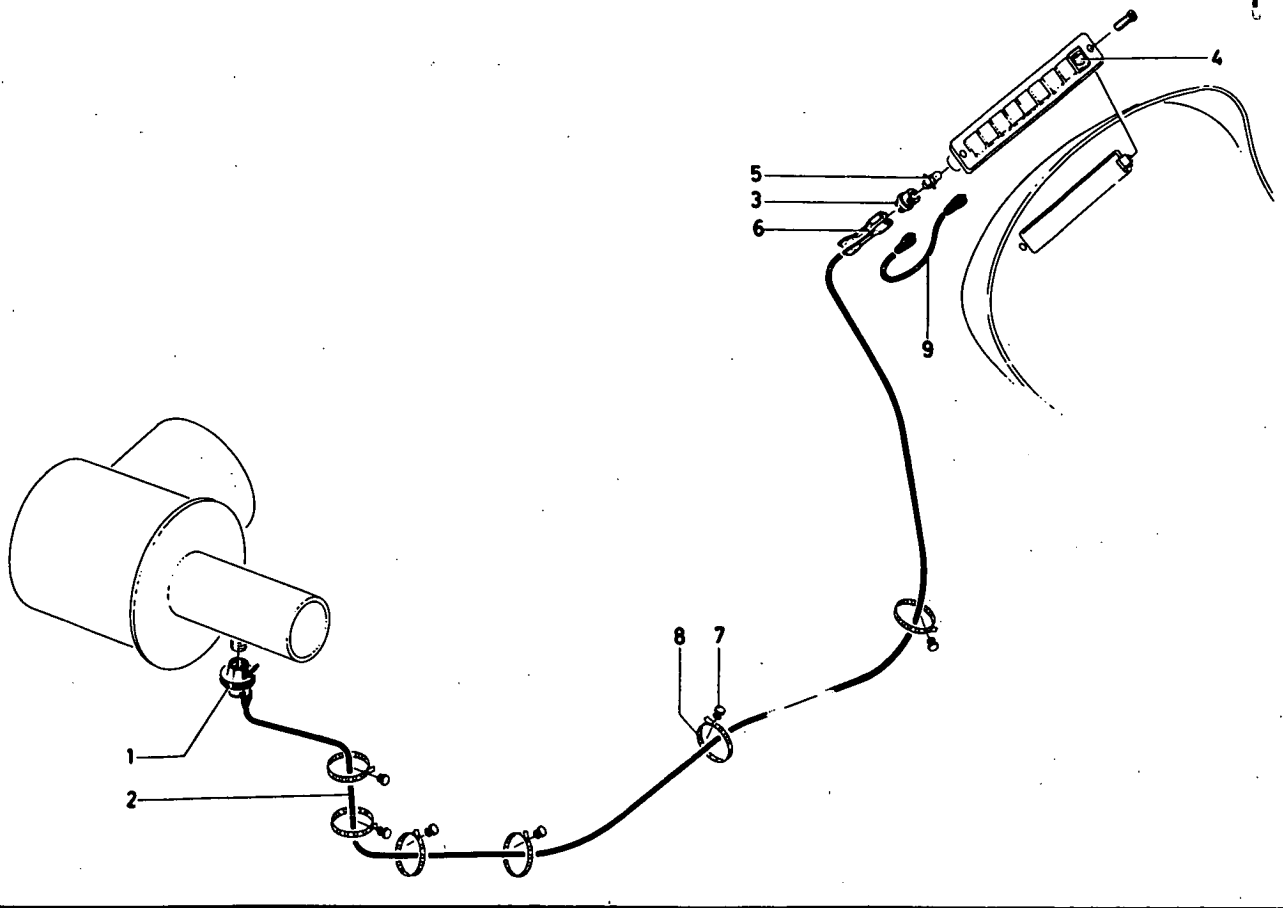

1001-43 500 4295

| Bild Nr. | Teil-Nr. | Stück-Zahl | Deutsch          | English            | Français          | Español            | Nummer/Bemerkung   | ETK |
|----------|----------|------------|------------------|--------------------|-------------------|--------------------|--------------------|-----|
| 1        | 216 6479 | 1          | UNTERDRUCKMESSER | SERVICE/VACU GAUGE | DEPRIMOMETRE      | VACUOMETRO         |                    |     |
| 2        | 233 8268 | 1          | LEITUNG          | LINE/LEAD          | CONDUCTEUR        | CONDUCTOR          |                    |     |
| 3        | 233 2900 | 1          | LAMPENFASSUNG    | LAMP SOCKET        | DOUILLE D AMPOULE | PORTALAMPARA       |                    |     |
| 4        | 233 2958 | 1          | SINNBILD         | SYMBOL             | EMBLEME           | SIMBOLO MARCA      |                    |     |
| 5        | 112 1432 | 1          | GLUEHLAMPE       | LIGHT BULB         | LAMPE A INCANDESC | BOMBILLA           | J 12V 2 W DIN72601 | 01  |
| 6        | 116 9065 | 1          | FLACHSTECKHUELSE | FEMALE PLUG        | DOILLE PLATE      | MEMBRA ENCHUF-PLAN | B 2.5 H 7602       |     |
| 7        | 116 4378 | 6          | BANDVERSCHLUSS   | STRAP              | FERMETURE BANDE   | CIERRA-CINTA       | EV 4 H 7672        |     |
| 8        | 116 4377 | 6          | BAND             | TAPE/STRAP/BAND    | RUBAN             | CINTA              | EB 4 H 7672        |     |
| 9        | 233 1281 | 9          | LEITUNG          | LINE/LEAD          | CONDUCTEUR        | CONDUCTOR          |                    |     |

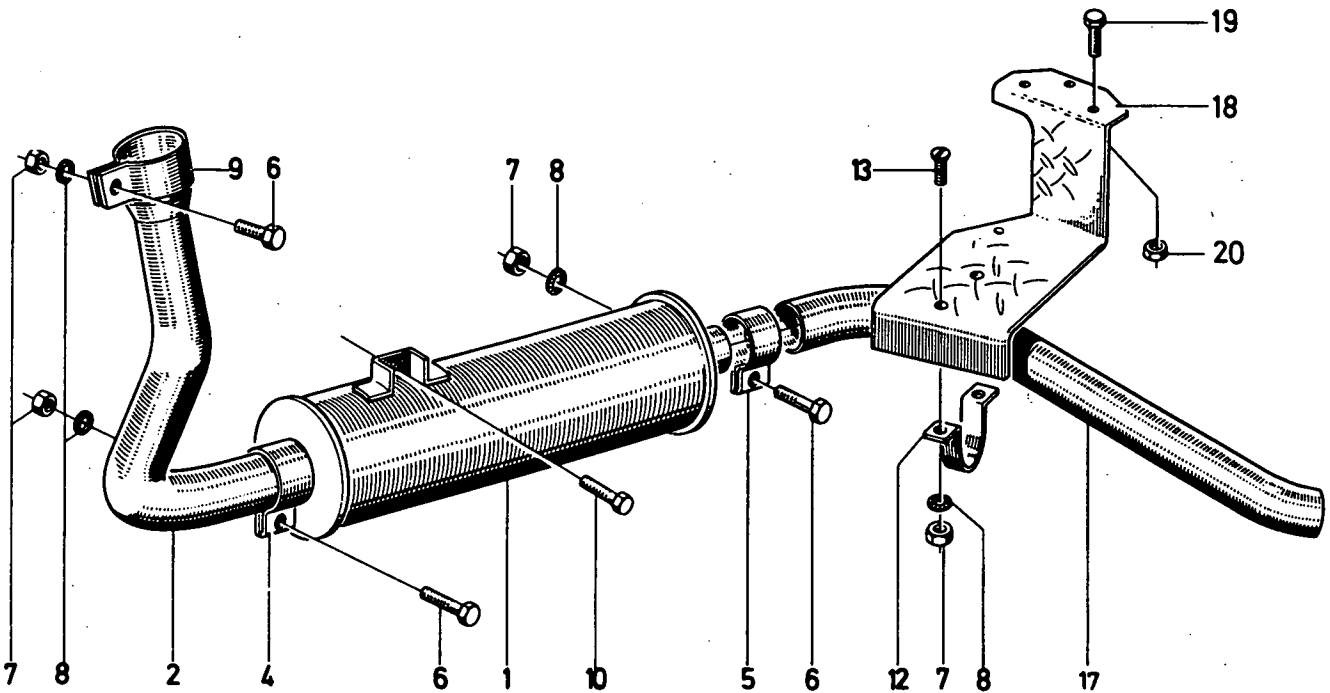

1003-44 500 4226

| Bld. Nr. | Teil-Nr. | Stück-Zahl | Deutsch           | English          | Français            | Español            | Nummer/Bemerkung          | ETK |
|----------|----------|------------|-------------------|------------------|---------------------|--------------------|---------------------------|-----|
| 1.       | 232 0874 | 1          | AUSPUFFTOPF       | EXHAUST SILENCER | POT D'ÉCHAPPEMENT   | SILENCIOSO ESCAPE  |                           |     |
| 2.       | 232 0884 | 1          | AUSPUFFROHR       | EXHAUST PIPE     | TUYAU D'ÉCHAPPEMENT | TUBO ESCAPE        |                           |     |
| 4.       | 338 9040 | 1          | ROHRSCHELLE       | PIPE CLIP        | COLLIER PR TUBES    | ABRAZADERA DE TUBO | 1136-44-05-04             |     |
| 5.       | 338 9041 | 1          | ROHRSCHELLE       | PIPE CLIP        | COLLIER PR TUBES    | ABRAZADERA DE TUBO | 1136-44-05-05             |     |
| 6.       | 111 2333 | 3          | SECHSKANTSCHRAUBE | HEX-BOLT         | VIS 6 PANS          | TORNILLO HEXAGONAL | M 8 X 25 DIN 933- 8-8-A4C |     |
| 7.       | 111 2824 | 5          | SECHSKANMUTTER    | HEX-NUT          | ECROU 6 PANS        | TUERCA HEXAGONAL   | M 8 DIN 934-M 8 A4C       |     |
| 8.       | 116 9689 | 5          | SICHERUNGSSCHEIBE | LOCKING WASHER   | RONDELLE SECURITE   | ARANDELA SEGURIDAD | 8 M 2303                  |     |
| 9.       | 338 9042 | 1          | ROHRSCHELLE       | PIPE CLIP        | COLLIER PR TUBES    | ABRAZADERA DE TUBO | 1136-44-05-13             |     |
| 10.      | 111 2538 | 1          | SECHSKANTSCHRAUBE | HEX-BOLT         | VIS 6 PANS          | TORNILLO HEXAGONAL | M12X 35 DIN 933-M 8-8-A4C |     |
| 12.      | 232 0876 | 1          | ROHRSCHELLE       | PIPE CLIP        | COLLIER PR TUBES    | ABRAZADERA DE TUBO |                           |     |
| 13.      | 113 2363 | 2          | SENKSCHEIBE       | C SUNK SCREW     | VIS TETE NOYEE      | TORN-CABZA-EMBTID  | M 8 X 25 DIN 87- 4-8-A4C  |     |
| 17.      | 233 0768 | 1          | AUSPUFFROHR       | EXHAUST PIPE     | TUYAU D'ÉCHAPPEMENT | TUBO ESCAPE        |                           |     |
| 18.      | 237 0870 | 1          | AUFTRITT          | FOOT PLATE       | MARCHE-PIED         | ESTRIBO            |                           |     |
| 19.      | 111 2264 | 3          | SECHSKANTSCHRAUBE | HEX-BOLT         | VIS 6 PANS          | TORNILLO HEXAGONAL | M 6 X 20 DIN 933- 8-8-A4C |     |
| 20.      | 111 2813 | 3          | SECHSKANMUTTER    | HEX-NUT          | ECROU 6 PANS        | TUERCA HEXAGONAL   | M 6 DIN 934-M 8 A4C       |     |



AUSPUFF NACH OBEN  
EXHAUST SYSTEM WITH OUTLET STACK  
SYSTEME D ECHAPPEMENT, D IRIGE VERS LE HAUT  
ESCAPE HACIA ARRIBA

7876/8814  
7868/0519

1001-44 500 6067

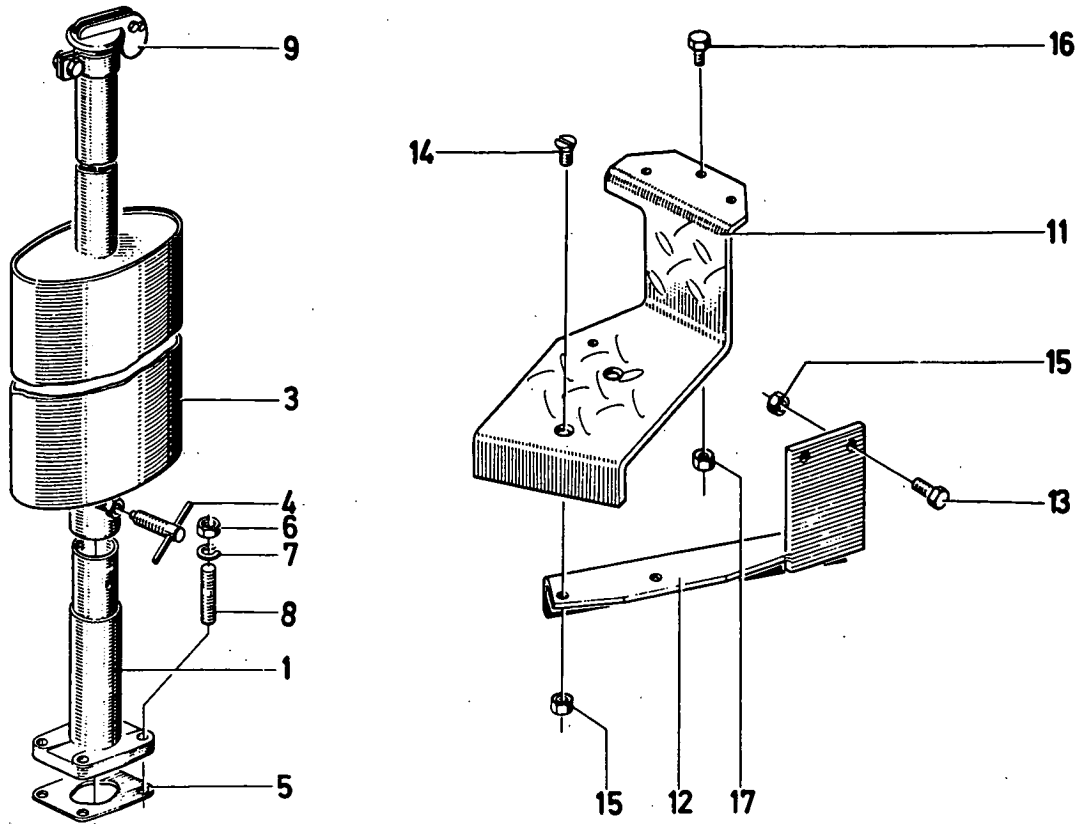

1001-44 500 6067

| Bld Nr. | Teil-Nr. | Stück-Zahl | Deutsch           | English           | Français           | Español            | Nummer/Bemerkung          | ETK |
|---------|----------|------------|-------------------|-------------------|--------------------|--------------------|---------------------------|-----|
| 1       | 231 1051 | 1          | STUTZEN           | SOCKET/ADAPTER    | TUBULURE/RACCORD   | TUBULADURA         |                           |     |
| 3       | 231 3911 | 1          | SCHALLDAEMPFER    | SILENCER          | SILENCIEUX         | SILENCIADOR        |                           |     |
| 4       | 231 2681 | 1          | KNEBELSCHRAUBE    | TOMMY SCREW       | VIS A GARROT       | TORNILLO MULETILLA |                           |     |
| 5       | 336 3929 | 1          | DICHTUNG          | GASKET            | GARNITURE/JOINT    | JUNTA              | 0150-41-408-09            | 03  |
| 6       | 331 6466 | 4          | SECHSKANTMUTTER   | HEX-NUT           | ECROU 6 PANS       | TUERCA HEXAGONAL   |                           | 03  |
| 7       | 110 2799 | 4          | FEDERRING         | SPRING LOCKWASHER | RONDELLE GROWER    | ARANDELA ELASTICA  | A 8 DIN 128 A4C           |     |
| 8       | 111 0187 | 4          | STIFTSCHRAUBE     | STUD              | GOIJON             | ESPARRAGO          | M 8 X 30 S44 DIN 835- 8-8 |     |
| 9       | 216 3249 | 1          | AUSPUFFKLAPPE     | EXHAUST FLAP      | CLAPET D ECHAPPENT | TRAMPILLA ESCAPE   |                           |     |
| 11      | 237 0870 | 1          | AUFTRITT          | FOOT PLATE        | MARCHE-PIED        | ESTRIBO            |                           |     |
| 12      | 237 3628 | 1          | STUETZE           | SUPPORT           | SUPPORT/APPUY      | APOYO              |                           |     |
| 13      | 111 2322 | 2          | SECHSKANTSCHRAUBE | HEX-BOLT          | VIS 6 PANS         | TORNILLO HEXAGONAL | M 8 X 20 DIN 933- 8-8-A4C |     |
| 14      | 110 1765 | 1          | SENKSCRAUBE       | C SUNK SCREW      | VIS TETE NOYEE     | TORN-CABZA-EMBUTID | M 8 X 25 DIN 87- 4-8-A4C  |     |
| 15      | 111 2824 | 2          | SECHSKANTMUTTER   | HEX-NUT           | ECROU 6 PANS       | TUERCA HEXAGONAL   | M 8 DIN 934-M 8 A4C       |     |
| 16      | 111 2264 | 3          | SECHSKANTSCHRAUBE | HEX-BOLT          | VIS 6 PANS         | TORNILLO HEXAGONAL | M 6 X 20 DIN 933- 8-8-A4C |     |
| 17      | 111 2813 | 3          | SECHSKANTMUTTER   | HEX-NUT           | ECROU 6 PANS       | TUERCA HEXAGONAL   | M 6 DIN 934-M 8 A4C       |     |

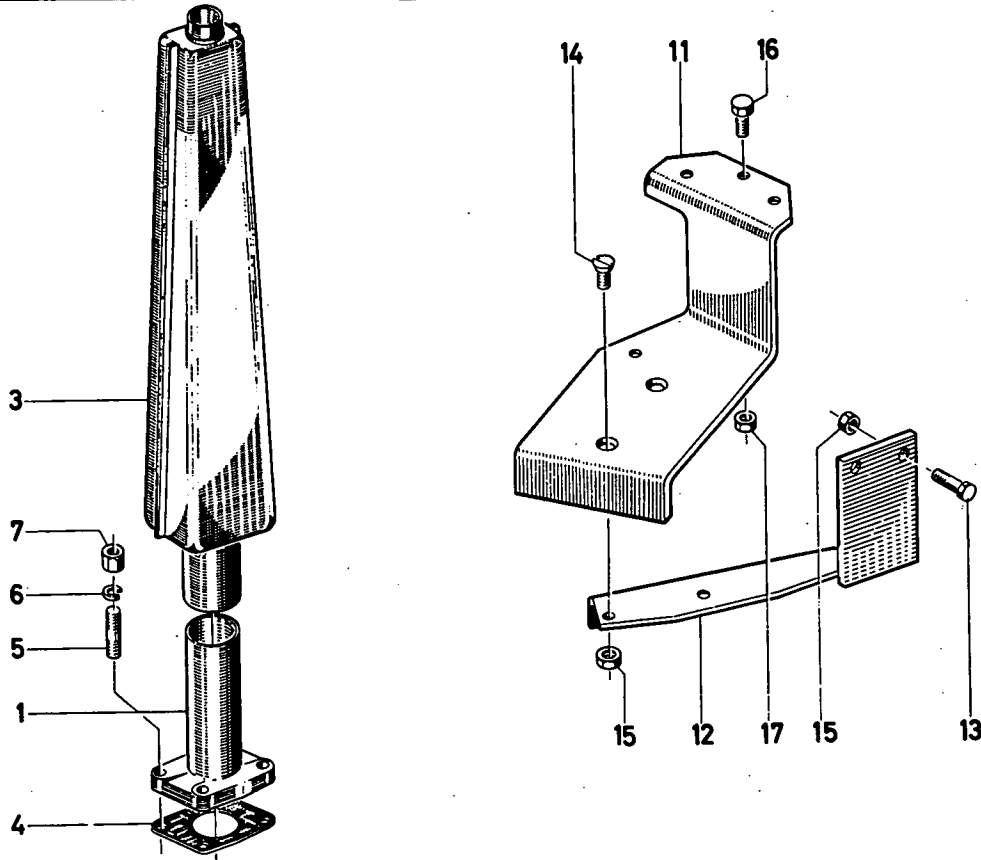

1003-44 502 0134

| Bild Nr. | Teile-Nr. | Stück-Zahl | Deutsch           | English           | Français         | Español            | Nummer/Bemerkung          | ETK |
|----------|-----------|------------|-------------------|-------------------|------------------|--------------------|---------------------------|-----|
| 1.       | 238 2769  | 1          | STUTZEN           | SOCKET/ADAPTER    | TUBULURE/RACCORD | TUBULADURA         |                           |     |
| 3.       | 238 2789  | 1          | SCHALLDAEMPFER    | SILENCER          | SILENCIEUX       | SILENCIADOR        |                           |     |
| 4.       | 336 3929  | 1          | DICHTUNG          | GASKET            | GARNITURE/JOINT  | JUNTA              | 0150-41-908-09            | 01  |
| 5.       | 111 0187  | 4          | STIFTSCHRAUBE     | STUD              | GOIJON           | ESPARRAGO          | M 8 X 30 S44 DIN 835- 8-8 |     |
| 6.       | 110 2799  | 4          | FEDERRING         | SPRING LOCKWASHER | RONDELLE GROMER  | ARANDELA ELASTICA  | A 8 DIN 128 A4C           |     |
| 7.       | 331 6466  | 4          | SECHSKANTMUTTER   | HEX-NUT           | ECROU 6 PANS     | TUERCA HEXAGONAL   |                           | 01  |
| 11.      | 237 0670  | 1          | AUFTRITT          | FOOT PLATE        | MARCHE-PIED      | ESTRIBO            |                           |     |
| 12.      | 237 3628  | 1          | STUETZE           | SUPPORT           | SUPPORT/APPUI    | APOYO              |                           |     |
| 13.      | 111 2322  | 2          | SECHSKANTSCHRAUBE | HEX-BOLT          | VIS 6 PANS       | TORNILLO HEXAGONAL | M 8 X 20 DIN 933- 8-8-A4C |     |
| 14.      | 110 1765  | 1          | SENKSCRAUBE       | C SUNK SCREW      | VIS TETE NOYEE   | TORN-CABZA-EMBTID  | M 8 X 25 DIN 87- 4-8-A4C  |     |
| 15.      | 111 2824  | 2          | SECHSKANTMUTTER   | HEX-NUT           | ECROU 6 PANS     | TUERCA HEXAGONAL   | M 8 DIN 934-M 8 A4C       |     |
| 16.      | 111 2264  | 3          | SECHSKANTSCHRAUBE | HEX-BOLT          | VIS 6 PANS       | TORNILLO HEXAGONAL | M 6 X 20 DIN 933- 8-8-A4C |     |
| 17.      | 111 2813  | 3          | SECHSKANTMUTTER   | HEX-NUT           | ECROU 6 PANS     | TUERCA HEXAGONAL   | M 6 DIN 934-M 8 A4C       |     |

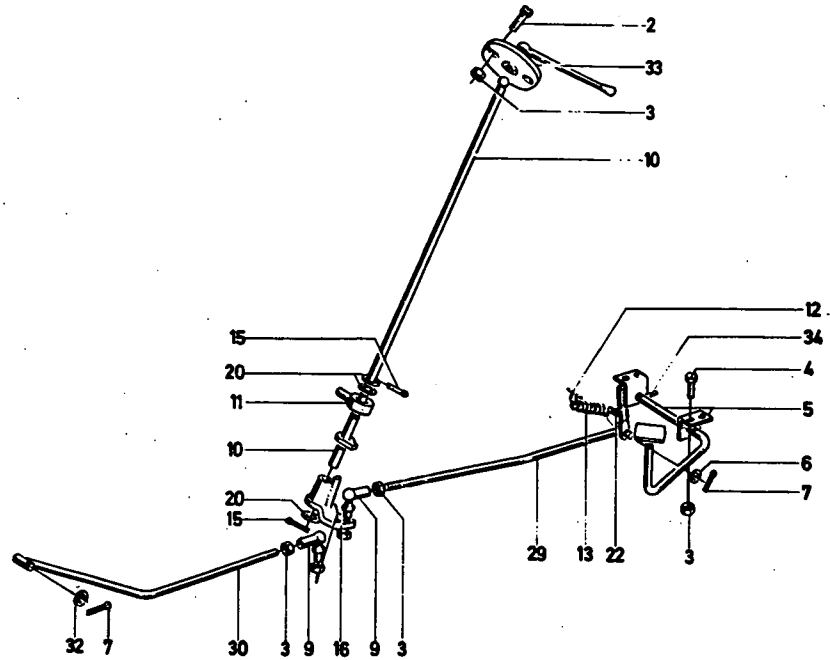

1001-46 500 4228

| Bild Nr. | Teile-Nr. | Stück-Zahl | Deutsch           | English         | Français           | Español            | Nummer/Bemerkung         | ETK |
|----------|-----------|------------|-------------------|-----------------|--------------------|--------------------|--------------------------|-----|
| 2        | 110 2020  | 2          | LINSENSCHRAUBE    | FILL-HEAD SCREW | VIS GOUTTE DE SUIF | TORN-CAB-LENTICUL- | 8Mx30DIN 7985- 4-8 VZKC  |     |
| 3        | 111 2813  | 8          | SECHSKANTMUTTER   | HEX-NUT         | ECROU 6 PANS       | TUERCA HEXAGONAL   | M 6 DIN 934-M 8 A4C      |     |
| 4        | 111 2851  | 4          | SECHSKANTSCHRAUBE | HEX-BOLT        | VIS 6 PANS         | TORNILLO HEXAGONAL | M 6x 18 DIN 933- 8-8-GAL |     |
| 5        | 230 6864  | 1          | PEDAL             | PEDAL           | PEDALE             | PEDAL              |                          |     |
| 6        | 110 7101  | 1          | SCHIEBE           | DISC/PANE/PLATE | RONDELLE/DISQUE    | DISCO              | A 8-4DIN 125-ST-A4C      |     |
| 7        | 110 6407  | 2          | SPLINT            | SPLIT PIN       | GOUPILLE FENDUE    | PASADOR ALETAS     | 2 X 15DIN 94-A4C         |     |
| 7        | 112 0436  | 2          | WINKELGELENK      | ANGLE JOINT     | ARTICULAT-D ANGLE  | ARTICULAC-ANGULAR  | A 10 DIN71802 VZKC       |     |
| 10       | 231 5545  | 1          | VERSTELLSTANGE    | ADJUSTING ROD   | TRINGLE DE REGLAGE | BARRA GRADUAC-     |                          |     |
| 10       | 231 5525  | 1          | HALTER            | RETAINER        | SUPPORT/PORTEOUTIL | SOPORTE            |                          |     |
| 12       | 338 8321  | 1          | FEDERBUEGEL       | SPRING CLAMP    | ETRIER DE RESSORT  | ESTRIBO RESORTE    | 1135-03-01-08            | 01  |
| 13       | 347 1076  | 1          | ZUGFEDER          | DRAW SPRING     | RESSORT TRACTION   | RESORTE TRACCION   | 1152-10-02-15            | 01  |
| 15       | 110 6451  | 2          | SPLINT            | SPLIT PIN       | GOUPILLE FENDUE    | PASADOR ALETAS     | 4 X 25DIN 94-A4C         |     |
| 16       | 231 5526  | 1          | MITNEHMER         | DRIVER/ACTUATOR | ENTRAINEUR/TOC     | ARRASTRADOR        |                          |     |
| 20       | 110 7114  | 3          | SCHIEBE           | DISC/PANE/PLATE | RONDELLE/DISQUE    | DISCO              | A 15 DIN 125-ST-A4C      |     |
| 22       | 110 6482  | 1          | SPLINT            | SPLIT PIN       | GOUPILLE FENDUE    | PASADOR ALETAS     | 6 X 35DIN 94-A4C         |     |
| 27       | 232 2673  | 1          | ZUGSTANGE         | PULLROD         | TIRANT             | BARRA TRACCION     |                          |     |
| 30       | 233 0764  | 1          | ZUGSTANGE         | PULLROD         | TIRANT             | BARRA TRACCION     |                          |     |
| 32       | 110 7095  | 1          | SCHIEBE           | DISC/PANE/PLATE | RONDELLE/DISQUE    | DISCO              | A 6-4DIN 125-ST-A4C      |     |
| 33       | 237 7646  | 1          | SPERRHEBEL        | LOCKING LEVER   | LEVIER DE BLOQUE   | PALANCA BLOQUEO    |                          |     |
| 34       | 111 5420  | 2          | SPANNHUELSE       | DOWEL SLEEVE    | DOUILLE SERRAGE    | CASQUILLO FIADOR   | 4 X 20DIN 1481           |     |

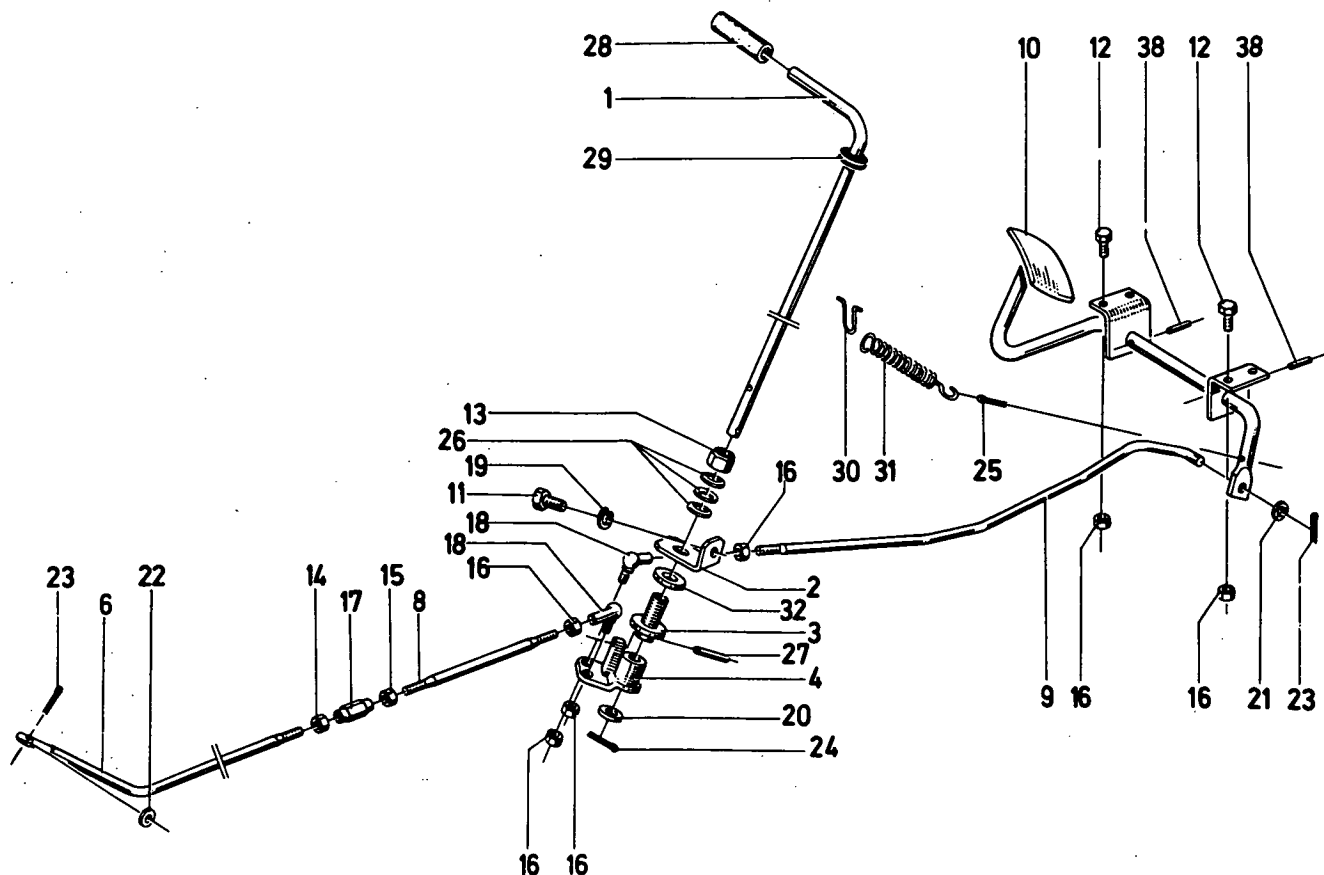

1001-46 500 6077

| Bild Nr. | Teil-Nr. | Stück-Zahl | Deutsch            | English           | Français           | Español            | Nummer/Bemerkung                               | ETK |
|----------|----------|------------|--------------------|-------------------|--------------------|--------------------|--|-----|
| 1        | 237 0407 | 1          | VERSTELLSTANGE     | ADJUSTING ROD     | TRINGLE DE REGLAGE | BARRA GRADUAC.     |  |     |
| 2        | 237 0408 | 1          | HALTEWINKEL        | ANGLED RETAINER   | EQUERRE DE SOUTIEN | ANGULO SUJECION    |  |     |
| 3        | 233 7892 | 1          | HUELSE             | SLEEVE            | DOUILLE            | CASQUILLO          |  |     |
| 4        | 237 0411 | 1          | MITNEHMER          | DRIVER/ACTUATOR   | ENTRAINEUR/TOC     | ARRASTRADOR        |  |     |
| 6        | 237 0410 | 1          | ZUGSTANGE          | PULLROD           | TIRANT             | BARRA TRACCION     |  |     |
| 8        | 231 5529 | 1          | ZUGSTANGE          | PULLROD           | TIRANT             | BARRA TRACCION     |  |     |
| 7        | 232 2673 | 1          | ZUGSTANGE          | PULLROD           | TIRANT             | BARRA TRACCION     |  |     |
| 10       | 230 6864 | 1          | PEDAL              | PEDAL             | PEDALE             | PEDAL              |  |     |
| 11       | 111 2322 | 1          | SECHSKANTSCHRAUBE  | HEX-BOLT          | VIS 6 PANS         | TORNILLO HEXAGONAL | M 8X20 DIN 933-M 8-8 A4C                       |     |
| 12       | 111 2251 | 4          | SECHSKANTSCHRAUBE  | HEX-BOLT          | VIS 6 PANS         | TORNILLO HEXAGONAL | M6X15 DIN 933-M6-8-A4C                         |     |
| 13       | 110 4568 | 1          | SECHSKANTMUTTER    | HEX-NUT           | ECROU 6 PANS       | TUERCA HEXAGONAL   | M 16X1,5 DIN 934-M8-A4C                        |     |
| 14       | 111 2824 | 1          | SECHSKANTMUTTER    | HEX-NUT           | ECROU 6 PANS       | TUERCA HEXAGONAL   | M8 DIN 934-M8-A4C                              |     |
| 15       | 111 2831 | 1          | SECHSKANTMUTTER    | HEX-NUT           | ECROU 6 PANS       | TUERCA HEXAGONAL   | M 8 LINKS DIN 934 M8 A4C<br>B 195-LINKSGEWINDE |     |
| 16       | 111 2813 | 8          | SECHSKANTMUTTER    | HEX-NUT           | ECROU 6 PANS       | TUERCA HEXAGONAL   | M 6 DIN 934-M8-A4C                             |     |
| 17       | 111-5360 | 1          | SPANNSCHLOSSMUTTER | TURNBUCKLE        | ECROU TENDEUR      | TUERCA CIERRE TENS | M 8DIN 1479 V2KC                               |     |
| 18       | 112 0947 | 2          | WINKELGELENK       | ANGLE JOINT       | ARTICULAT-D ANGLE  | ARTICULAC-ANGULAR  | AS 13 DIN 71802 A4C                            |     |
| 19       | 110 2799 | 1          | FEDERRING          | SPRING LOCKWASHER | RONDELLE GROUER    | ARANDELA ELASTICA  | A 8 DIN 128 A4C                                |     |
| 20       | 110 7110 | 1          | SCHEIBE            | DISC/PANE/PLATE   | RONDELLE/DISQUE    | DISCO              | A13 DIN 125-ST-A4C                             |     |
| 21       | 110 7101 | 1          | SCHEIBE            | DISC/PANE/PLATE   | RONDELLE/DISQUE    | DISCO              | 8,4 DIN 125-A4C                                |     |
| 22       | 110 7095 | 1          | SCHEIBE            | DISC/PANE/PLATE   | RONDELLE/DISQUE    | DISCO              | 6,4 DIN 125-ST-A4C                             |     |
| 23       | 110 6407 | 2          | SPLINT             | SPLIT PIN         | GOUPILLE FENDUE    | PASADOR ALETAS     | 2X15 DIN 96 V2KC                               |     |
| 24       | 110 6447 | 1          | SPLINT             | SPLIT PIN         | GOUPILLE FENDUE    | PASADOR ALETAS     | 4 X 20DIN 94 V2KC                              |     |
| 25       | 110 6482 | 1          | SPLINT             | SPLIT PIN         | GOUPILLE FENDUE    | PASADOR ALETAS     | 6 X 35DIN 94 V2KC                              |     |
| 26       | 111 6039 | 3          | TELLERFEDER        | CUP SPRING        | RESSORT BELLEVILLE | RESORTE DE PLATO   | B 31,5 DIN 2093                                |     |
| 27       | 111-5430 | 1          | SPANNHUELSE        | DOWEL SLEEVE      | DOUILLE SERRAGE    | CASQUILLÓ FIADOR   | 4 X 32DIN 1481                                 |     |

| Bild Nr. | Teil-Nr. | Stück-Zahl | Deutsch     | English       | Français           | Español          | Nummer/Bemerkung | ETK |
|----------|----------|------------|-------------|---------------|--------------------|------------------|------------------|-----|
| 28       | 237 0419 | 1          | GRIF        | HANDLE        | POIGNEE/MANETTE    | PUNO/ASA         |                  |     |
| 29       | 237 0412 | 1          | MUFFE       | SLEEVE        | MANCHON            | MANGUITO         |                  |     |
| 30       | 338 8321 | 1          | FEDERBUEGEL | SPRING CLAMP  | ETRIER DE RESSORT  | ESTRIBO RESORTE  | 1135-03-01-08    | 01  |
| 31       | 347 1076 | 1          | ZUGFEDER    | DRAW SPRING   | RESSORT TRACTION   | RESORTE TRACCION | 1152-10-02-15    | 01  |
| 32       | 233 7893 | 1          | REIBSCHEIBE | FRICTION DISC | DISQUE DE FRICTION | PLATO FRICCION   |                  |     |
| 38       | 111 5420 | 2          | SPANNHUELSE | DOWEL SLEEVE  | DOUILLE SERRAGE    | CASQUILLO FIADOR | 4 X 20DIN 1481   |     |

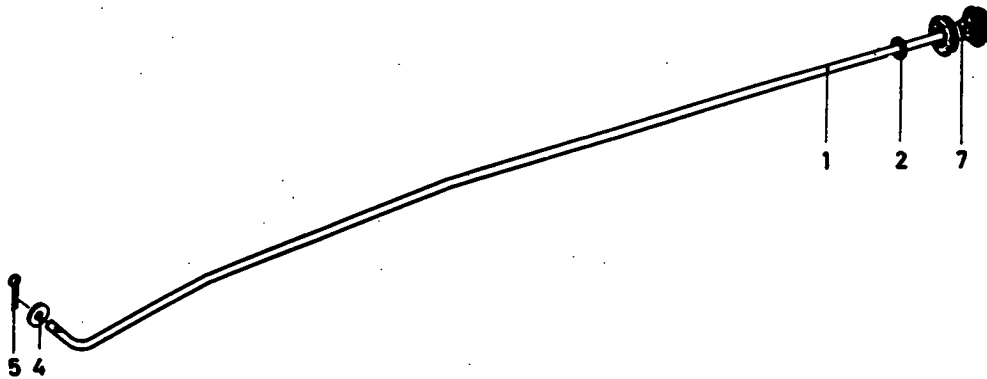

1003-47 500 3012

| Bild Nr. | Teil-Nr. | Stück-Zahl | Deutsch   | English         | Français        | Español        | Nummer/Bemerkung     | ETK |
|----------|----------|------------|-----------|-----------------|-----------------|----------------|----------------------|-----|
| 1        | 232 5769 | 1          | ZUGSTANGE | PULLROD         | TIRANT          | BARRA TRACCION |                      |     |
| 2        | 232 5768 | 1          | TUELLE    | GROMMET         | DOUILLE         | FUNDA          |                      |     |
| 4        | 110 7089 | 1          | SCHEIBE   | DISC/PANE/PLATE | RONDELLE/DISQUE | DISCO          | A 5.30IN 125-ST-44C. |     |
| 5        | 110 6404 | 1          | SPLINT    | SPLIT PIN       | GOUPILLE FENDUE | PASADOR ALETAS | 2 X 1.20IN 94-44C    |     |
| 7        | 233 1263 | 1          | KNOPF     | BUTTON/KNOB     | BOUTON          | BOTON          |                      |     |



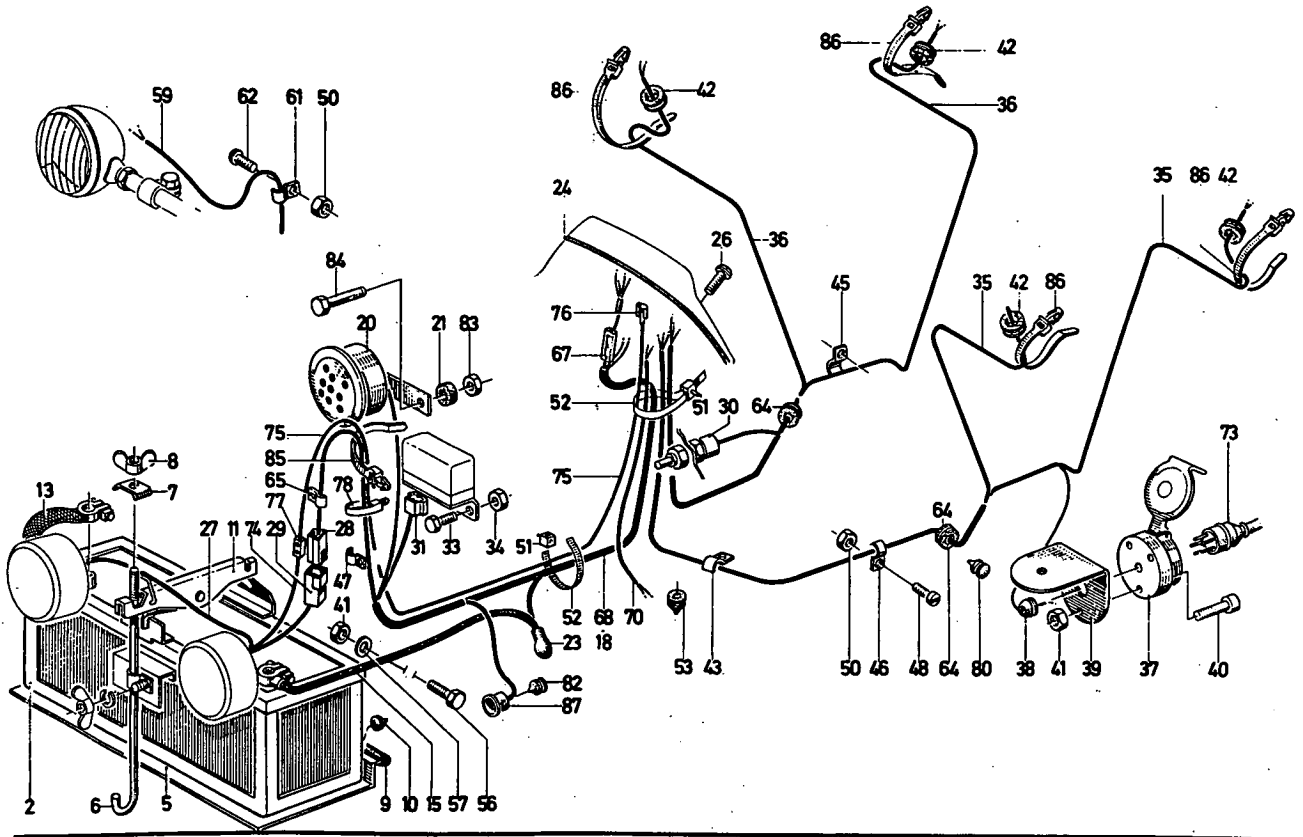

| Bild Nr. | Teile-Nr. | Stück-Zahl | Deutsch            | English           | Français           | Español            | 1001-49 500 4230<br>Nummer/Bemerkung | ETK |
|----------|-----------|------------|--------------------|-------------------|--------------------|--------------------|--------------------------------------|-----|
| 2        | 112 1069  | 1          | BATTERIE           | BATTERY           | BATTERIE           | BATERIA            | 12V 88AH395A DIN72311                |     |
| 5        | 231 1490  | 1          | AUFLAGEBLECH       | SUPPORT PLATE     | TOLE D APPUI.      | CHAPA DE ASIENTO   |                                      |     |
| 6        | 233 9498  | 1          | NAKENSCHRAUBE      | HOOK SCREW        | VIS A CROCHET      | TORNILLO CANCAMO   |                                      |     |
| 7        | 338 9438  | 1          | STUETZBLECH        | SUPPORT PLATE     | TOLE D APPUI       | CHAPA APOYO        | 1145-49-01-95                        |     |
| 8        | 110 7359  | 1          | FLUEGELNUTTER      | WING NUT          | ECROU A AILETTES   | TUERCA MARIPOSA    | M 8 DIN 315-6 6TW35 VZKC             |     |
| 9        | 116 8964  | 1          | GUMMIPROFIL        | RUBBER SECTION    | PROFIL CAOUTCHOUC  | PERFIL CAUCHO      | V 1,5 X 8 X 9 X 375H 7560-6B         |     |
| 10       | 121 0432  | 2          | KNOPF              | BUTTON/KNOB       | BOUTON             | BOTON              | 7 565 D 2                            |     |
| 11       | 231 9677  | 1          | HALTER             | RETAINER          | SUPPORT/PORTEOUTIL | SOPORTE            |                                      |     |
| 13       | 233 8244  | 1          | MASSBAND           | EARTH LEAD        | BANDE MISE A MASSE | CINTA A MASA       |                                      |     |
| 15       | 338 9460  | 1          | KABEL              | WIRE/CABLE        | CABLE              | CABLE              | 1145-49-32-10                        |     |
| 18       | 233 1394  | 1          | KABELSATZ          | SET OF WIRING     | JEU DE CABLES      | LOTE CABLE         |                                      |     |
| 20       | 116 9304  | 1          | HORN               | HORN              | KLAXON             | BOCINA             | 100 X12 H 7650                       |     |
| 21       | 338 7988  | 1          | RING               | RING              | BAGUE/ANNEAU       | ANILLO             | 1125-49-11-21                        |     |
| 23       | 116 9030  | 1          | SCHUTZKAPPE        | CAP               | CAPUCHON PROTECT   | SOMBRETE PROTEC.   | K18 H 7565                           | 01  |
| 24       | 233 4058  | 1          | DICHTUNG           | GASKET            | GARNITURE/JOINT    | JUNTA              |                                      |     |
| 26       | 110 3389  | 2          | LINSENSCHRAUBE     | FILL.-HEAD SCREW  | VIS GOUTTE DE SUIF | TORN-CAB-LENTICUL. | AM6X20DIN 7985- 4-8 A4C              |     |
| 27       | 233 1395  | 1          | KABELSATZ          | SET OF WIRING     | JEU DE CABLES      | LOTE CABLE         | B112-FUER SCHEINWERFER               |     |
| 28       | 116 2367  | 1          | STECKERGEHAEUSE    | PLUG HOUSING      | CORPS FICHE CONT   | CAJA ENCHUFE       | H2 H 7642                            |     |
| 29       | 116 3204  | 1          | STECKERGEHAEUSE    | PLUG HOUSING      | CORPS FICHE CONT   | CAJA ENCHUFE       | H9 H 7642                            |     |
| 30       | 116 2929  | 1          | BREMSLICHTSCHALTER | STOP LIGHT SWITCH | COMMUT FEU STOP    | COMMUT-TIRO FRENO  | C1H 7659                             |     |
| 31       | 116 1165  | 1          | STECKDOSE          | SOCKET            | PRISE DE COURANT   | CAJA ENCHUFE       | G1 H 7642                            |     |
| 33       | 111 2258  | 2          | SECHSKANTSCHRAUBE  | HEX.BOLT          | VIS 6 PANS         | TORNILLO HEXAGONAL | M 6X 18 DIN 933- 8-8-A4C             |     |
| 34       | 111 2833  | 2          | SECHSKANTNUTTER    | HEX.NUT           | ECROU 6 PANS       | TUERCA HEXAGONAL   | M 6 DIN 934-M 8 A4C                  |     |
| 35       | 233 3215  | 1          | KABELSATZ          | SET OF WIRING     | JEU DE CABLES      | LOTE CABLE         | B151-HINTEN-LINKS                    |     |
| 36       | 233 3216  | 1          | KABELSATZ          | SET OF WIRING     | JEU DE CABLES      | LOTE CABLE         | B152-HINTEN-RECHTS                   |     |

| Bild Nr. | Teil-Nr. | Stück-Zahl | Deutsch           | English           | Français           | Español            | Nummer/Bemerkung                    | ETK |
|----------|----------|------------|-------------------|-------------------|--------------------|--------------------|-------------------------------------|-----|
| 37       | 117 0426 | 1          | STECKDOSE         | SOCKET            | PRISE DE COURANT   | CAJA ENCHUFE       | A7 H 7692                           |     |
| 38       | 338 9107 | 1          | TUELLE            | GROMMET           | DOUILLE            | FUNDA              | 1136-49-16-49                       |     |
| 39       | 231 6013 | 1          | HALTER            | RETAINER          | SUPPORT/PORTEQUIL  | SOPORTE            |                                     |     |
| 40       | 112 3582 | 3          | ZYLINDERSCHRAUBE  | CHEESE-HEAD SCREW | VIS TETE CYLINDR.  | TORN-CBZA-CILIND.  | M 5 X 30 DIN 84- 4-8-A4C            |     |
| 41       | 111 2803 | 3          | SECHSKANTMUTTER   | HEX-NUT           | ECROU 6 PANS       | TUERCA HEXAGONAL   | M 5 DIN 934-M 8 A4C                 |     |
| 42       | 116 7412 | 4          | GUMMITUELLE       | RUBBER GROMMET    | GAINÉ CAOUTCHOUC   | FUNDA CAUCHO       | B10 X15 X 1,6 H 2928                |     |
| 43       | 231 1632 | 2          | SCHELLE           | CLIP              | COLLIER            | ABRAZADERA         |                                     |     |
| 45       | 112 1249 | 8          | SCHELLE           | CLIP              | COLLIER            | ABRAZADERA         | 1 X 6 DIN 72571 VZKC                |     |
| 46       | 112 1253 | 4          | SCHELLE           | CLIP              | COLLIER            | ABRAZADERA         | 1 X 8 DIN 72571 VZKC                |     |
| 47       | 112 1255 | 2          | SCHELLE           | CLIP              | COLLIER            | ABRAZADERA         | 1 X 10 DIN 72571 VZKC               |     |
| 48       | 111 9628 | 12         | LINSENSCHRAUBE    | FILL.-HEAD SCREW  | VIS GOUTTE DE SUIF | TORN-CAB-LENTICUL. | M 4 X 10 DIN 7985- 4-8 VZKC         |     |
| 50       | 111 2746 | 16         | SECHSKANTMUTTER   | HEX-NUT           | ECROU 6 PANS       | TUERCA HEXAGONAL   | M 4 DIN 934-M 8 A4C                 |     |
| 51       | 116 4378 | 6          | BANDVERSCHLUSS    | STRAP             | FERMETURE BANDE    | CIERRA-CINTA       | EV 4 H 7672                         |     |
| 52       | 116 4377 | MTR        | BAND              | TAPE/STRAP/BAND   | RUBAN              | CINTA              | EB 4 H 7672                         |     |
| 53       | 116 7326 | 2          | VERSCHLUSSSTOPFEN | NIPPLE            | BOUCHON            | TAPON OBTURADOR    | A22,5 H 2873                        |     |
| 56       | 111 2305 | 1          | SECHSKANTSCHRAUBE | HEX-BOLT          | VIS 6 PANS         | TORNILLO HEXAGONAL | M 8 X 15 DIN 933- 8-8-A4C           |     |
| 57       | 110 7101 | 1          | SCHIEBE           | DISC/PANE/PLATE   | RONDELLE/DISQUE    | DISCO              | A 8,4 DIN 125-ST-A4C                |     |
| 59       | 231 3810 | 1          | KABELSATZ         | SET OF WIRING     | JEU DE CABLES      | LOTE CABLE         | B124-FUER SCHEINWERFER-AUSSEN       |     |
| 61       | 112 1251 | 6          | SCHELLE           | CLIP              | COLLIER            | ABRAZADERA         | 1 X 7 DIN 72571 VZKC                |     |
| 62       | 111 9630 | 4          | LINSENSCHRAUBE    | FILL.-HEAD SCREW  | VIS GOUTTE DE SUIF | TORN-CAB-LENTICUL. | M 4 X 15 DIN 7985- 4-8 VZKC         |     |
| 64       | 116 7425 | 2          | GUMMITUELLE       | RUBBER GROMMET    | GAINÉ CAOUTCHOUC   | FUNDA CAUCHO       | D13-5X17 X 1,5 H 2928               |     |
| 65       | 230 4486 | 4          | KABELKLENME       | CABLE CLAMP/TERM. | BORNE DE CABLE     | BORNE CABLE        |                                     |     |
| 67       | 116 9436 | 1          | LEITUNGSVERBINDER | WIRE CONNECTOR    | CONNECTEUR         | LIGA-TUBERIAS      | F1H 7677                            |     |
| 68       | 233 5822 | 1          | KABELSATZ         | SET OF WIRING     | JEU DE CABLES      | LOTE CABLE         | B105-FUER GLEICHSTROM LICHTMASCHINE |     |
| 70       | 233 0763 | 1          | KABELSATZ         | SET OF WIRING     | JEU DE CABLES      | LOTE CABLE         |                                     |     |
| 73       | 112 1327 | 1          | STECKER           | PLUG              | FICHE DE CONTACT   | CLAVIJA ENCHUFE    | B7 DIN 72577                        |     |
| 74       | 233 5360 | 1          | LEITUNG           | LINE/LEAD         | CONDUCTEUR         | CONDUCTOR          | BILUX                               |     |
| 75       | 233 5361 | 1          | LEITUNG           | LINE/LEAD         | CONDUCTEUR         | CONDUCTOR          | BILUX                               |     |
| 76       | 116 9062 | 1          | FLACHSTECKHUELSE  | FEMALE PLUG       | DOILLE PLATE       | MEMBRA ENCHUF.PLAN | B 1 H 7602                          |     |
| 77       | 116 9436 | 1          | LEITUNGSVERBINDER | WIRE CONNECTOR    | CONNECTEUR         | LIGA-TUBERIAS      | F1H 7677                            |     |
| 78       | 116 1085 | 18         | KABELBAND         | CABLE STRAP       | RUBAN PR CABLE     | CINTA ATACABLES    | B 15 H 7672                         |     |
| 80       | 230 2835 | 1          | VERSCHLUSSSTOPFEN | NIPPLE            | BOUCHON            | TAPON OBTURADOR    |                                     |     |
| 82       | 237 2476 | 1          | STOPFEN           | PLUG              | BOUCHON            | TAPON              |                                     |     |
| 83       | 111 2824 | 1          | SECHSKANTMUTTER   | HEX-NUT           | ECROU 6 PANS       | TUERCA HEXAGONAL   | M 8 DIN 934-M 8 A4C                 |     |
| 84       | 111 2322 | 1          | SECHSKANTSCHRAUBE | HEX-BOLT          | VIS 6 PANS         | TORNILLO HEXAGONAL | M 8 X 20 DIN 933- 8-8-A4C           |     |
| 85       | 117 2065 | 3          | BAND              | TAPE/STRAP/BAND   | RUBAN              | CINTA              | G 150 X5 H 7672                     |     |
| 86       | 116 4749 | 4          | BAND              | TAPE/STRAP/BAND   | RUBAN              | CINTA              | F 6,5-4,5X197H 7672                 |     |
| 87       | 116 9028 | 1          | SCHUTZKAPPE       | CAP               | CAPUCHON PROTECT   | SOMBRETE PROTEC.   | K 6 H 7565                          | 01  |



SCHALTKASTEN - ARMATUREN  
 MAIN SWITCH - INSTRUMENTATION  
 TABLEAU DE BORD ET INSTRUMENTS  
 CAJA DE CONEXIONES, INSTRUMENTOS

1001-49 500 6211

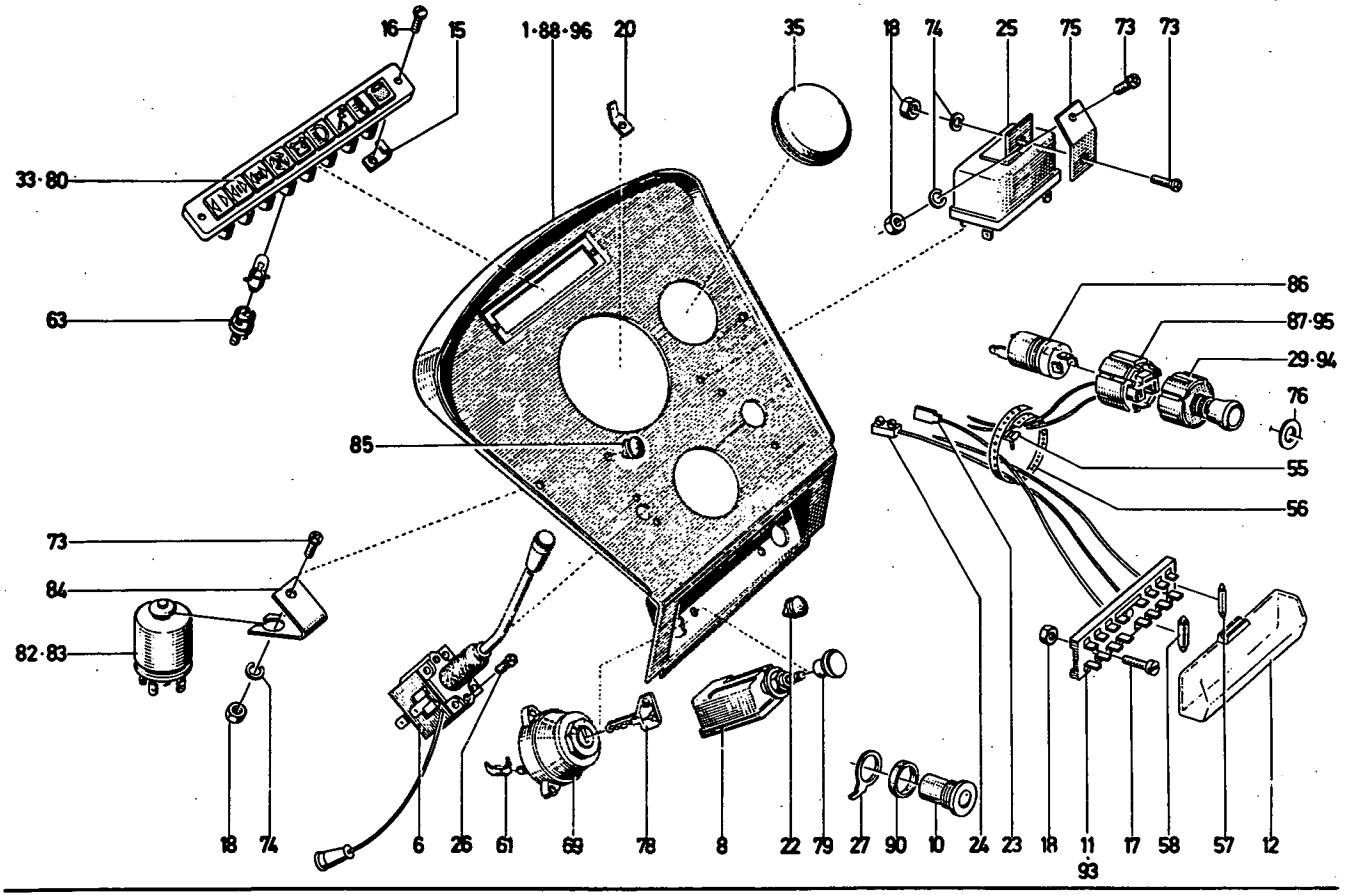

1001-49 500 6211

| Bild Nr. | Teil-Nr. | Stück-Zahl | Deutsch            | English            | Français             | Español              | Nummer/Bemerkung  | ETK |
|----------|----------|------------|--------------------|--------------------|----------------------|----------------------|---|-----|
| 1        | 233 4039 | 1          | SCHALTKASTEN       | MAIN SWITCH        | COFFRET COMMANDE     | CAJA CONEXIONES      | B136-FUER MECHAN.-U.-HYDROLENK.-<br>B027-BIS FAHRGESTELL-NO.<br>B004-AB FAHRGESTELL-NO POS.88 |     |
| 6        | 116 3922 | 1          | BLINKLICHTSCHALTER | BLINKER SWITCH     | COMMUT.-CLIGNOTS     | COMNUTAD.-INTERMITT. | E 1 H 7660  |     |
| 8        | 116 3920 | 1          | GLUEHANLASSCHALTER | PREH-/START SWITCH | COMM RECH/DEMARR     | COMNUT.-ARRANG.-INC. | CF H 7662   |     |
| 10       | 116 9232 | 1          | STECKDOSE          | SOCKET             | PRISE DE COURANT     | CAJA ENCHUFE         | C H 7642  |     |
| 11       | 116 3916 | 1          | SICHERUNGSDOSE     | FUSE BOX           | BOITE A FUSIBLES     | CAJA FUSIBLES        | A 852H 7644<br>B027-BIS FAHRGESTELL-NO<br>B004-AB FAHRGESTELL-NO POS.93                       |     |
| 12       | 233 2876 | 1          | BECKEL             | COVER              | COUVERCLE            | TAPA                 |   |     |
| 15       | 121 2896 | 2          | MUTTER             | NUT                | ECROU                | TUERCA               | 2 169 A 12 IN KLAMMER   |     |
| 16       | 110 3519 | 2          | ZYLINDERSCHRAUBE   | CHEESE-HEAD SCREW  | VIS TETE CYLINDR.    | TORN.-CBZA.-CILIND.  | AM 5 X 15 DIN 24- 4.8-A4C   |     |
| 17       | 110 5526 | 2          | ZYLINDERSCHRAUBE   | CHEESE-HEAD SCREW  | VIS TETE CYLINDR.    | TORN.-CBZA.-CILIND.  | 4,2x13 DIN( 7983 A4C  |     |
| 18       | 111 2803 | 2          | SECHSKANTMUTTER    | HEX-NUT            | ECROU 6 PANS         | TUERCA HEXAGONAL     | M 5 DIN 934-M 2 A4C   |     |
| 20       | 121 0566 | 1          | FLACHSTECKER       | FLAT PLUG          | FICHE PLATE          | ENCHUFE PLANO        | 7 602 B 1   |     |
| 22       | 116 3730 | 1          | VERSCHLUSSSTOPPEN  | NIPPLE             | BOUCHON              | TAPON OETURADOR      | A12.5X 9.5H 2273  |     |
| 23       | 116 9436 | 1          | LEITUNGSVERBINDER  | WIRE CONNECTOR     | CONNECTEUR           | LIGADOR CABLES       | F1H 7677  |     |
| 24       | 116 2414 | 1          | LEITUNGSVERBINDER  | WIRE CONNECTOR     | CONNECTEUR           | LIGADOR CABLES       | G1H 7677  |     |
| 25       | 116 3952 | 1          | RELAIS             | RELAY              | RELAIS               | RELAIS               | 1 H12VF H 7606  |     |
| 26       | 110 4150 | 2          | LINSENSCHRAUBE     | FILL.-HEAD SCREW   | VIS GOUTTE DE SUIF   | TORN.-CAE.-LENTICUL. | M4X 5DIN 7965- 4.2 A4C  |     |
| 27       | 233 1376 | 1          | BLECH              | PLATE              | TOLE                 | CHAPA                |   |     |
| 29       | 116 3921 | 1          | WARNBLINKSCHALTER  | EN-BLINKER SWITCH  | COMM.-SIGN.-DETRESS. | CONN.-INTERMI.-ALARM | C 4 H 7660<br>B027-BIS FAHRGESTELL-NO<br>B004-AB FAHRGESTELL-NO POS.94                        |     |
| 33       | 233 1300 | 1          | ANZEIGELEUCHTE     | PILOT LIGHT        | LAMPE-TEMOIN         | LAMPARA AVISO        | B266-SIEHE TAFEL-NO<br>1001-49 500 5314   |     |
| 35       | 237 2747 | 1          | BECKEL             | COVER              | COUVERCLE            | TAPA                 | 1136-49-02-04   |     |
| 55       | 116 4378 | 5          | BANDVERSCHLUSS     | STRAP              | FERMETURE BANDE      | CIERRA-CINTA         | EV 4 H 7672   |     |

| Bld Nr. | Teil-Nr. | Stück-Zahl | Deutsch           | English           | Français           | Español            | Nummer/Bemerkung   | ETK |
|---------|----------|------------|-------------------|-------------------|--------------------|--------------------|--|-----|
| 56      | 116 4377 | MTR        | BAND              | TAPE/STRAP/BAND   | RUBAN              | CINTA              |  |     |
| 57      | 112 1330 | 6          | SCHMELZEINSATZ    | FUSE              | ELEMENT FUSIBLE    | ELEMENTO FUSIBLE   | A 8DIN72581  | 01  |
| 58      | 110 3177 | 2          | SCHMELZEINSATZ    | FUSE              | ELEMENT FUSIBLE    | ELEMENTO FUSIBLE   | A 16DIN72581   | 01  |
| 61      | 116 9070 | 1          | VERTEILER         | DISTRIBUTOR       | DISTRIBUTEUR       | DISTRIBUIDOR/DELCO | 1 BCL H 7602<br>B027-BIS FAHRGESTELL-NO                  |     |
| 63      | 233 2900 | 1          | FASSUNG           | SOCKET/HOLDER     | DOUILLE            | ZOCALO LAMPARA     |  |     |
| 64      | 117 1411 | 1          | LICHTSCHALTER     | LIGHT SWITCH      | INTERRUPTEUR D ECL | CONMUTAD-ALUMBRADO | C 3 H 7661   |     |
| 73      | 111 9632 | 1          | LINSENSCHRAUBE    | FILL-HEAD SCREW   | VIS GOUTTE DE SUIF | TORN-CAB-LENTICUL- | MSX10DIN 7985- 4-2 A4C                                   |     |
| 74      | 110 276  | 1          | FEBERRING         | SPRING LOCKWASHER | RONDELLE GROVER    | ARANDELA ELASTICA  | A 5 DIN 128 A4C  |     |
| 75      | 233 5812 | 1          | WINKEL            | ANGLE PLATE       | EQUERRE            | ANGULO             |  |     |
| 76      | 110 7110 | 1          | SCHLEIBE          | DISC/PANE/PLATE   | RONDELLE/DISQUE    | DISCO              | A13 DIN 125-ST-A4C                                       |     |
| 78      | 116 4422 | 2          | ZUENDSCHLUESSEL   | IGNITION KEY      | CLE DE CONTACT     | LLAVE CONTACTO     | C2H 7661   |     |
| 79      | 233 9821 | 1          | KNOPF             | BUTTON/KNOB       | BOUTON             | BOTON              |  |     |
| 80      | 233 9827 | 1          | ANZEIGELEUCHTE    | PILOT LIGHT       | LAMPE-TENOIN       | LAMPARA AVISO      | B286-SIEHE TAFEL-NO<br>1001-49 500 5314                  |     |
| 82      | 116 9338 | 1          | BLINKGEBER        | BLINKER RELAY     | BOITE CLIGNOTANTE  | RELAIS INTERMIT-   | A 2 H 7660   |     |
| 83      | 116 4674 | 1          | BLINKGEBER        | BLINKER RELAY     | BOITE CLIGNOTANTE  | RELAIS INTERMIT-   | A 2-21W H 7660   |     |
| 84      | 237 456  | 1          | HALTER            | RETAINER          | SUPPORT/PORTEQUIL  | SOPORTE            |  |     |
| 85      | 116 4675 | 1          | VERSCHLUSSSTOPFEN | NIPPLE            | BOUCHON            | TAPON OBTURADOR    | 2H 5.8X 8.5X 7 H 7665-SW                                 |     |
| 86      | 238 9220 | 1          | WARNBLinkGEBER    | EM-BLINKER GENER- | BOITE CLIGNOTANTE  | RELE INTERMIT-     | WBR1 H 7660  |     |
| 87      | 237 4611 | 1          | STECKER           | PLUG              | FICHE DE CONTACT   | CLAVIJA ENCHUFE    | B027-BIS FAHRGESTELL-NO<br>B004-AB FAHRGESTELL-NO POS-95 |     |
| 88      | 237 9168 | 1          | SCHALTASTEN       | MAIN SWITCH       | COFFRET COMMANDE   | CAJA CONEXIONES    | B138-FUER MECHANISCHE UND<br>HYDROLENKUNG                |     |
| 90      | 238 0174 | 1          | RING              | RING              | BAGUE/ANNEAU       | ANILLO             |  |     |
| 93      | 117 1416 | 1          | SICHERUNGSDOSE    | FUSE BOX          | BOITE A FUSIBLES   | CAJA FUSIBLES      | A 853H 7644  |     |
| 94      | 117 1418 | 1          | WARNBLinkSCHALTER | EM-BLINKER SWITCH | COMM-SIGN-DETRESS- | COMM-INTERMI-ALARM | C 5 H 7660   |     |
| 95      | 238 0163 | 1          | STECKER           | PLUG              | FICHE DE CONTACT   | CLAVIJA ENCHUFE    |  |     |
| 96      | 238 4775 | 1          | SCHALTASTEN       | MAIN SWITCH       | COFFRET COMMANDE   | CAJA CONEXIONES    | B106-FUER HYDROLENKUNG                                   |     |



ANZEIGELEUCHTE  
PILOT LAMP  
LAMPE - TÉMOIN  
LAMPARA DE ALERTA

1001-49 500 5314

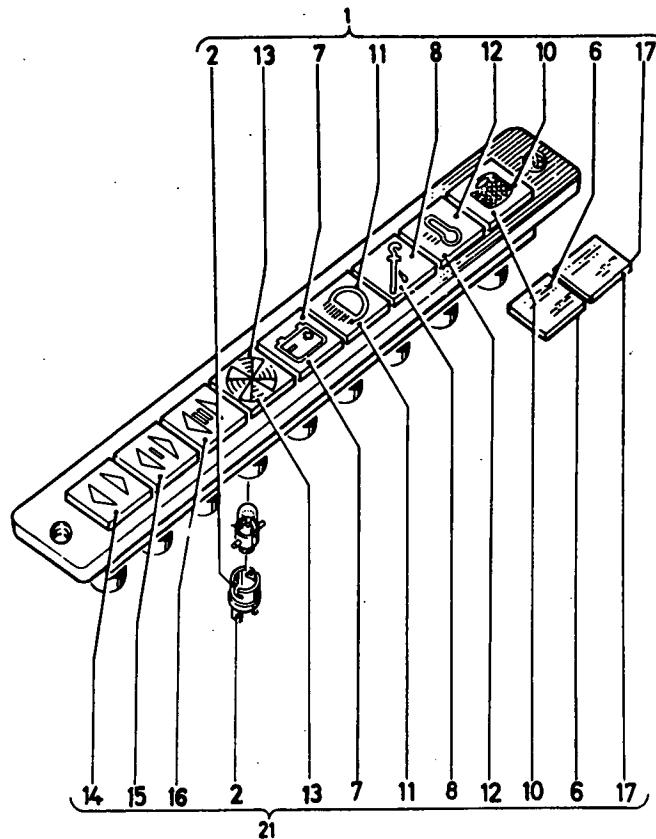

1001-49 500 5314

| Bild Nr. | Teile-Nr. | Stück-Zahl | Deutsch        | English       | Français          | Español            | Nummer/Bemerkung                          | ETK |
|----------|-----------|------------|----------------|---------------|-------------------|--------------------|---|-----|
| 1        | 233 1300  | 1          | ANZEIGELEUCHTE | PILOT LIGHT   | LAMPE-TÉMOIN      | LAMPARA AVISO      | 8250 OHNE BLINKLICHT, OHNE TANKANZEIGE    |     |
| 2        | 233 2900  | 1          | FASSUNG        | SOCKET/HOLDER | DOUILLE           | ZOCALO LAMPARA     |   |     |
| 6        | 233 2954  | 7          | KAPPE          | CAP           | CAPUCHON/CALOTTE  | SOMBRETT-/CAPUCHON |   |     |
| 7        | 233 2955  | 1          | SINNBILD       | SYMBOL        | EMBLEME           | SIMBOLO MARCA      | 8116 FUER LADEKONTROLLE                   |     |
| 8        | 233 2956  | 1          | SINNBILD       | SYMBOL        | EMBLEME           | SIMBOLO MARCA      | 8117 FUER OELDRÜCKKONTROLLE               |     |
| 10       | 233 2958  | 1          | SINNBILD       | SYMBOL        | EMBLEME           | SIMBOLO MARCA      | 8118 FUER FILTERKONTROLLE                 |     |
| 11       | 233 3801  | 1          | SINNBILD       | SYMBOL        | EMBLEME           | SIMBOLO MARCA      | 8119 FUER FERNLICHTKONTROLLE<br>UNTERLAGE |     |
| 12       | 233 9602  | 1          | SINNBILD       | SYMBOL        | EMBLEME           | SIMBOLO MARCA      | 8120 FUER TEMPERATURANZEIGE               |     |
| 13       | 233 9603  | 1          | SINNBILD       | SYMBOL        | EMBLEME           | SIMBOLO MARCA      | 8121 FUER GEBLÄSE                         |     |
| 14       | 233 9628  | 1          | SINNBILD       | SYMBOL        | EMBLEME           | SIMBOLO MARCA      | 8123 FUER BLINKLICHT FUER<br>ZUGMASCHINE  |     |
| 15       | 233 9829  | 1          | SINNBILD       | SYMBOL        | EMBLEME           | SIMBOLO MARCA      | 8122 FUER BLINKLICHT FUER 1<br>ANHAENGER  |     |
| 16       | 233 9830  | 1          | SINNBILD       | SYMBOL        | EMBLEME           | SIMBOLO MARCA      | 8122 FUER BLINKLICHT FUER 2<br>ANHAENGER  |     |
| 17       | 237 6738  | 1          | ANZEIGESCHEIBE | DIAL          | DISQUE INDICATEUR | ESFERA INDICACION  | 8045 BEI SCHEINWERFER OBEN                |     |
| 21       | 233 9827  | 1          | ANZEIGELEUCHTE | PILOT LIGHT   | LAMPE-TÉMOIN      | LAMPARA AVISO      | 8219 MIT BLINKLICHT OHNE<br>TANKANZEIGE   |     |



ZEITUHR  
TIME WATCH  
MONTRE DE TEMPS  
RELOJ DE TIEMPO

1001-49 502 0184

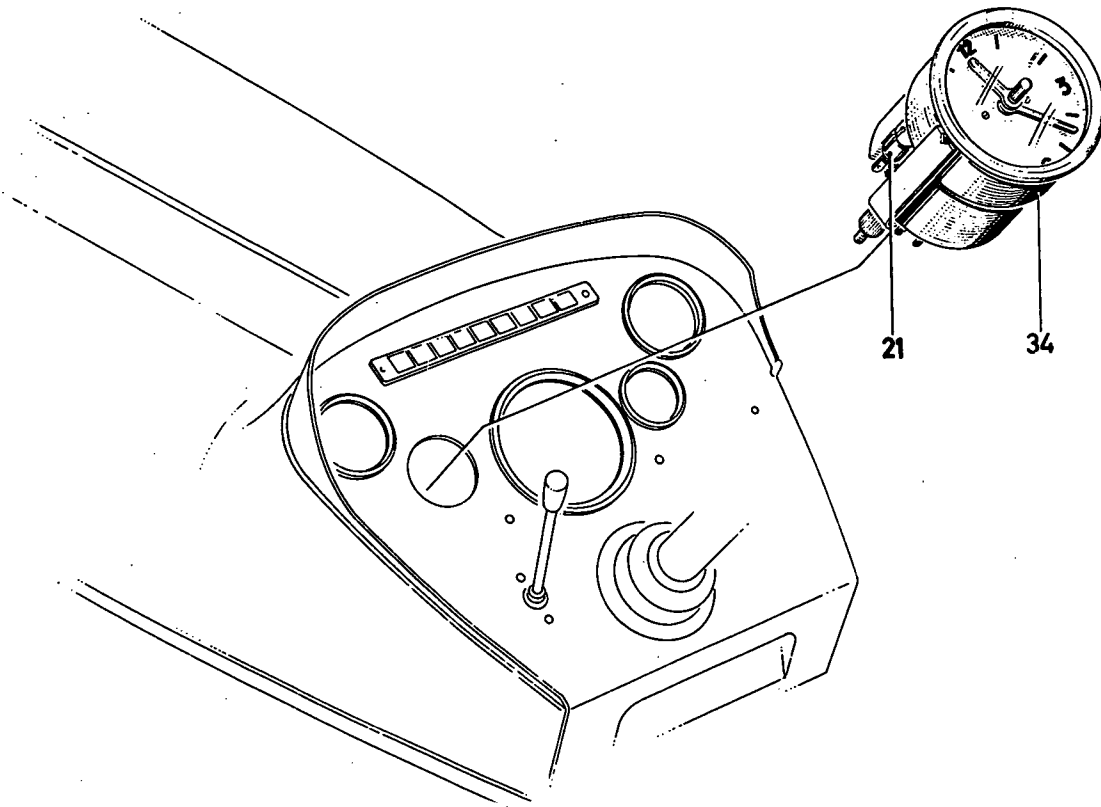

| Bild<br>Nr. | Teile-Nr. | Stück-<br>Zahl |            |                  |                    |                  | 1001-49 502 0184    | ETK |
|-------------|-----------|----------------|------------|------------------|--------------------|------------------|---------------------|-----|
|             |           |                | Deutsch    | English          | Français           | Español          | Nummer / Bemerkung  |     |
| 21          | 112 1432  | 1              | GLUEHLAMPE | LIGHT BULB       | LANPE A INCANDESC  | BOMBILLA         | J. 12V 2W DIN 72601 | 01  |
| 34          | 116 3780  | 1              | UHR        | CLOCK/DIAL GAUGE | MONTRE/COMPARATEUR | RELOJ/CRONOMETRO | A 60X12 V H 4237    |     |

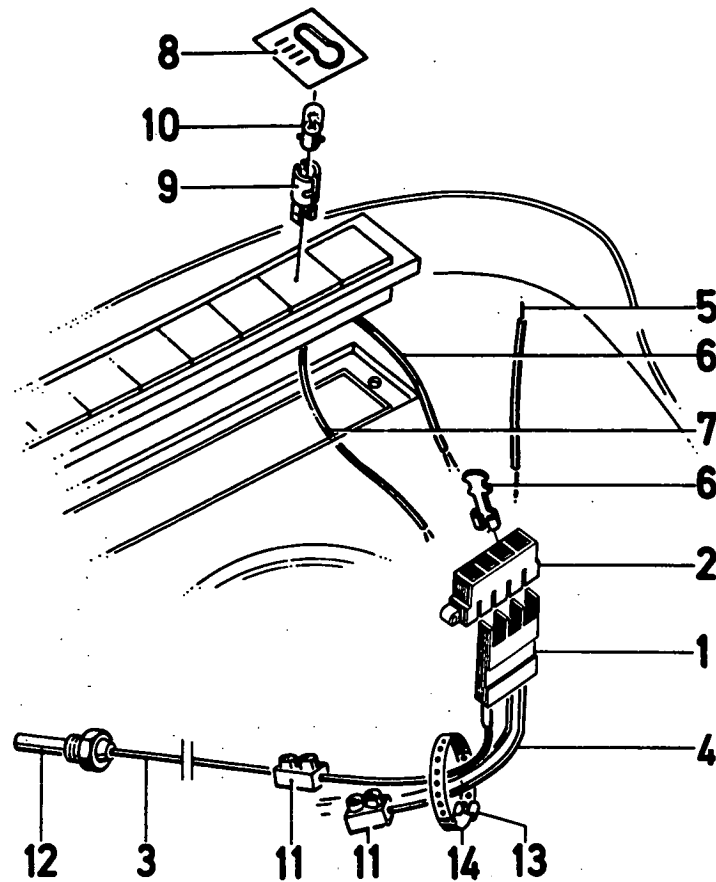

| Bild Nr. | Teil-Nr. | Stück-Zahl | Deutsch           | English         | Français          | Español            | 1001-49 502 0185<br>Nummer/Bemerkung | ETK |
|----------|----------|------------|-------------------|-----------------|-------------------|--------------------|--------------------------------------|-----|
| 1        | 116 4588 | 1          | RELAIS            | RELAY           | RELAIS            | RELAIS             | D12V-150W H 7607                     |     |
| 2        | 116 4587 | 1          | STECKVERBINDER    | PLUG CONNECTION | CONNEXION ENFICH  | LIGADOR ENCHUFE    | H 7 H 7642                           |     |
| 3        | 237 5593 | 1          | LEITUNG           | LINE/LEAD       | CONDUCTEUR        | CONDUCTOR          |                                      |     |
| 4        | 237 5590 | 1          | LEITUNG           | LINE/LEAD       | CONDUCTEUR        | CONDUCTOR          |                                      |     |
| 5        | 237 5592 | 1          | LEITUNG           | LINE/LEAD       | CONDUCTEUR        | CONDUCTOR          |                                      |     |
| 6        | 237 5589 | 1          | LEITUNG           | LINE/LEAD       | CONDUCTEUR        | CONDUCTOR          |                                      |     |
| 7        | 237 5588 | 1          | LEITUNG           | LINE/LEAD       | CONDUCTEUR        | CONDUCTOR          |                                      |     |
| 8        | 233 7602 | 1          | KAPPE             | CAP             | CAPUCHON/CALOTTE  | SOMBRETE-/CAPUCHON |                                      |     |
| 9        | 233 2700 | 1          | PASSUNG           | SOCKET/HOLDER   | DOUILLE           | ZOCALO LAMPARA     |                                      |     |
| 10       | 112 1432 | 1          | GLUEHLAMPE        | LIGHT BULB      | LAMPE A INCANDESC | BOMBILLA           | J 12V 20 W H 7601                    | 01  |
| 11       | 116 4936 | 2          | LEITUNGSVERBINDER | WIRE CONNECTOR  | CONNECTEUR        | LIGA-TUBERIAS      | F3H 7677                             |     |
| 12       | 213 0498 | 1          | KONTAKTGEBER      | CONTACT MAKER   | CONTACTEUR        | TRANSISOR CONTACT  |                                      |     |
| 13       | 116 4378 | 2          | BANDVERSCHLUSS    | STRAP           | FERRURE BANDE     | CIERRA-CINTA       | EV 4 H 7672                          |     |
| 14       | 116 4377 | NTR        | BAND              | TAPE/STRAP/BAND | RUBAN             | CINTA              | EB 4 H 7672                          |     |



SCHEINWERFER - NORMAL  
 HEADLAMPS - STANDARD  
 PHARES - NORMAL  
 FAROS - NORMAL

1001-49 500 5430

Fax 0532 66283

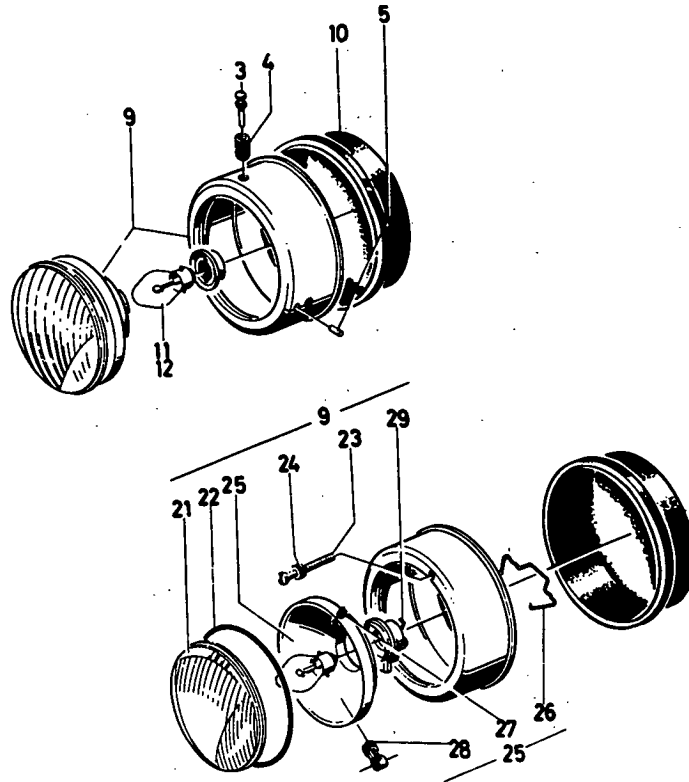

1001-49 500 5430

| Bld Nr. | Teile-Nr. | Stück-Zahl | Deutsch           | English         | Français          | Español            | Nummer/Bemerkung                      | ETK |
|---------|-----------|------------|-------------------|-----------------|-------------------|--------------------|---------------------------------------|-----|
| 3       | 230 6326  | 6          | STIFT             | PIN             | CHEVILLE/GOUPILLE | PERNO/PASADOR      |                                       |     |
| 4       | 230 6327  | 6          | KNOPF             | BUTTON/KNOB     | BOUTON            | BOTON              |                                       |     |
| 5       | 230 6328  | 4          | GUMMISTOPFEN      | RUBBER PLUG     | BOUCHON CAOUTCH   | TAPON CAUCHO       |                                       |     |
| 9       | 233 4989  | 2          | SCHEINWERFER      | HEADLIGHT       | PHARE             | FARO               | B337 VOLLSTAENDIG                     |     |
| 10      | 233 1059  | 2          | SCHUTZKAPPE       | CAP             | CAPUCHON PROTECT  | SOMBRETERE PROTEC- |                                       |     |
| 11      | 112 1383  | 2          | GLUEHLAMPE        | LIGHT BULB      | LAMPE A INCANDESC | BOMBILLA           | D 12V 35 W DIN72601                   | 01  |
| 12      | 110 4333  | 2          | GLUEHLAMPE        | LIGHT BULB      | LAMPE A INCANDESC | BOMBILLA           | D 12V 35 W DIN72601 GELB<br>B145 GELB | 01  |
| 21      | 237 0586  | 2          | STREUSCHEIBE      | DIFFUSOR        | DIFFUSEUR         | CRISTAL DIFUSOR    |                                       |     |
| 22      | 233 2189  | 2          | DICHTUNG          | GASKET          | GARNITURE/JOINT   | JUNTA              |                                       | 01  |
| 23      | 110 6256  | 4          | LINSENKENSCHRAUBE | OVAL-HEAD SCREW | VIS A BOIS NOYEE  | TORN-CAB-EMBUIDO-  | CM 4 X 50DIN 91- 4-8 VERCHR           |     |
| 24      | 233 2190  | 4          | BUCHSE            | BUSH            | DOUILLE           | CASQUILLO          |                                       |     |
| 25      | 237 0585  | 2          | REFLEKTOR         | REFLECTOR       | REFLECTEUR        | REFLECTOR          |                                       |     |
| 26      | 127 6020  | 2          | SPANNBUEGEL       | CLAMPING YOKE   | ETRIER SERRAGE    | ESTRIBO FIJACION   |                                       | 01  |
| 27      | 237 0583  | 2          | BUCHSE            | BUSH            | DOUILLE           | CASQUILLO          |                                       |     |
| 28      | 237 0584  | 4          | GEMINDESTOPFEN    | THREADED PLUG   | BOUCHON FILETE    | TAPON ROSCADO      |                                       |     |
| 29      | 237 0587  | 2          | LAMPENFASSUNG     | LAMP SOCKET     | DOUILLE D AMPOULE | PORTALAMPARA       |                                       |     |



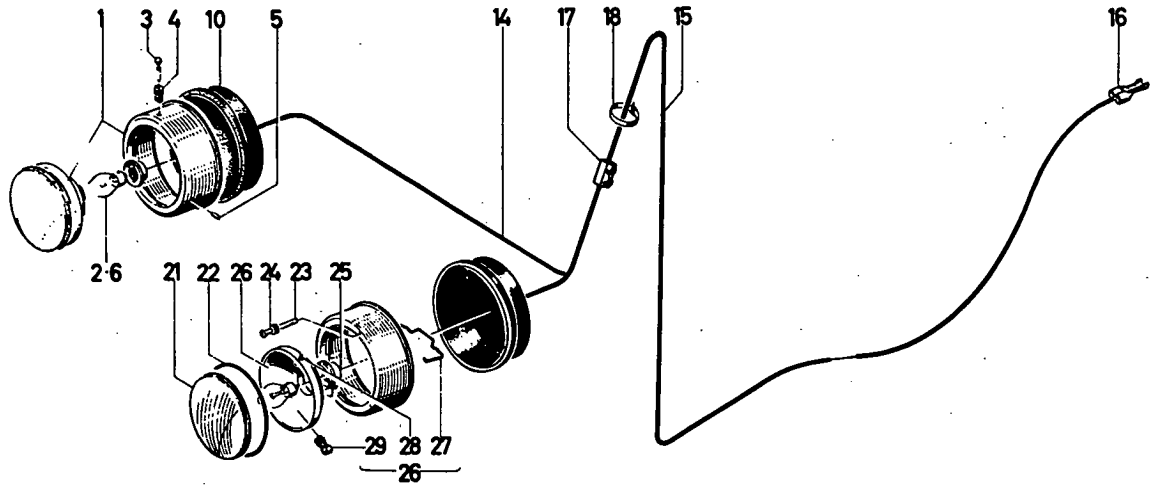

1001-49 500 5429

| Bild Nr. | Teil-Nr. | Stück-Zahl | Deutsch          | English         | Français           | Español            | Nummer/Bemerkung                        | ETK |
|----------|----------|------------|------------------|-----------------|--------------------|--------------------|---|-----|
| 1        | 230 6919 | 2          | SCHEINWERFER     | HEADLIGHT       | PHARE              | FARO               |   |     |
| 2        | 112 1372 | 2          | GLUEHLAMPE       | LIGHT BULB      | LAMPE A INCANDESC  | BOMBILLA           | B 12V 35 W/35DIN72601                   | 01  |
| 3        | 230 6326 | 6          | STIFT            | PIN             | CHEVILLE/GOUPILLE  | PERNO/PASADOR      |   |     |
| 4        | 230 6327 | 6          | KNOPF            | BUTTON/KNOB     | BOUTON             | BOTON              |   |     |
| 5        | 230 6328 | 4          | GUMMISTOPFEN     | RUBBER PLUG     | BOUCHON CAOUTCH    | TAPON CAUCHO       |   |     |
| 6        | 112 1373 | 2          | GLUEHLAMPE       | LIGHT BULB      | LAMPE A INCANDESC  | BOMBILLA           | B 12V 35 W/35DIN72601 GELB<br>0145-6ELB | 01  |
| 10       | 233 1059 | 2          | SCHUTZKAPPE      | CAP             | CAPUCHON PROTECT   | SOMBRETE PROTEC.   |   |     |
| 14       | 233 5360 | 2          | LEITUNG          | LINE/LEAD       | CONDUCTEUR         | CONDUCTOR          |   |     |
| 15       | 233 5361 | 2          | LEITUNG          | LINE/LEAD       | CONDUCTEUR         | CONDUCTOR          |   |     |
| 16       | 116 9062 | 2          | FLACHSTECKHUELSE | FEMALE PLUG     | BOILLE PLATE       | HEMBRA ENCHUF-PLAN | B 1 H 7602                              |     |
| 17       | 116 9436 | 2          | VERBINDER        | CONNECTOR/UNION | RACCORD/CONNECTEUR | LIGADOR            | F1H 7677                                |     |
| 18       | 116 1085 | 16         | KABELBAND        | CABLE STRAP     | RUBAN PR CABLE     | CINTA ATACABLES    | B 15 H 7672                             |     |
| 21       | 233 2186 | 2          | STREUSCHEIBE     | DIFFUSOR        | DIFFUSEUR          | CRISTAL DIFUSOR    |   |     |
| 22       | 233 2189 | 2          | DICHTUNG         | GASKET          | GARNITURE/JOINT    | JUNTA              |   | 01  |
| 23       | 110 6256 | 4          | LINSENKESCHRAUBE | OVAL-HEAD SCREW | VIS A BOIS NOYEE   | TORN-CAB-EMBUTID.  | CM 4 X 50DIN 93- 4-8 VERCHR             |     |
| 24       | 233 2190 | 4          | BUECHSE          | BUSH            | BOITE              | CASQUILLO          |   |     |
| 25       | 233 2192 | 2          | LAMPENFASSUNG    | LAMP SOCKET     | DOUILLE D AMPOULE  | PORTALAMPARA       |   |     |
| 26       | 237 0585 | 2          | REFLEKTOR        | REFLECTOR       | REFLECTEUR         | REFLECTOR          |   |     |
| 27       | 127 6020 | 2          | SPANNBUEGEL      | CLAMPING YOKE   | ETRIER SERRAGE     | ESTRIBO FIJACION   |   | 01  |
| 28       | 237 0583 | 2          | BUECHSE          | BUSH            | BOITE              | CASQUILLO          |   |     |
| 29       | 237 0584 | 4          | GEWINDESTUECK    | THREADED PIECE  | PIECE FILETEE      | PZA-ROSCADA        |   |     |

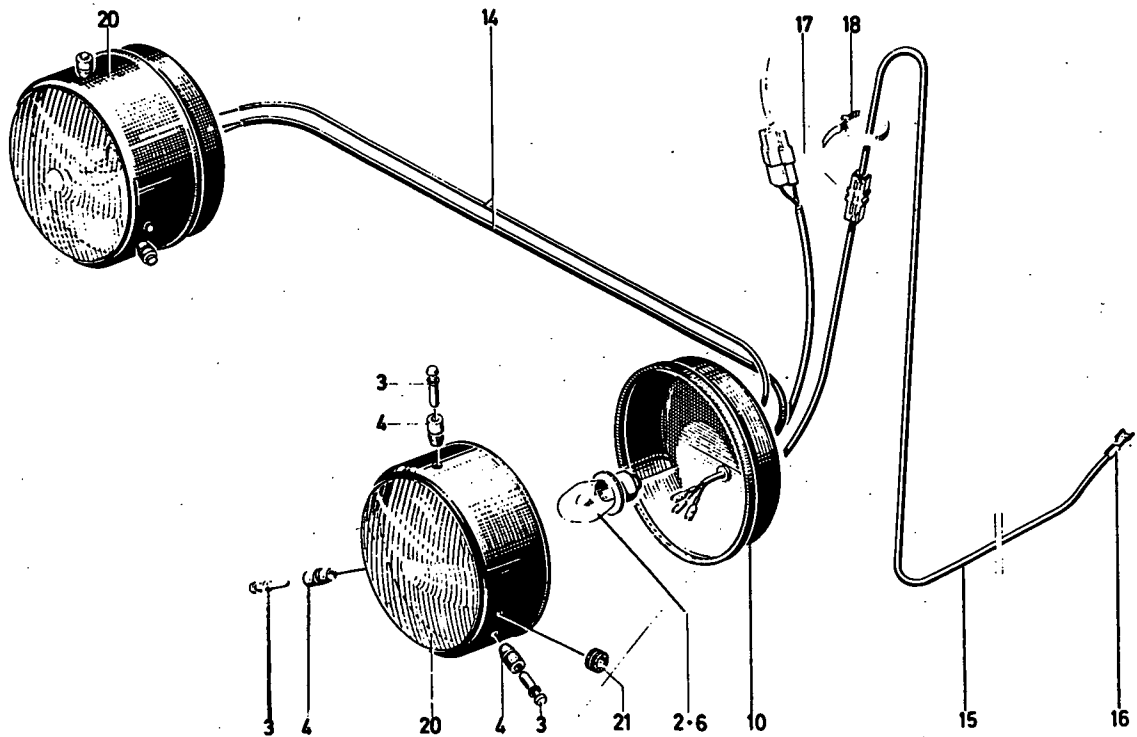

| Bild Nr. | Teil-Nr. | Stück-Zahl | Deutsch           | English        | Français          | Español            | 1001-49 502 0183<br>Nummer / Bemerkung  | ETK |
|----------|----------|------------|-------------------|----------------|-------------------|--------------------|---|-----|
| 2        | 112 1372 | 2          | GLUEHLAMPE        | LIGHT BULB     | LAMPE A INCANDESC | BOMBILLA           | B 12V 35 W/35DIN72601                   | 03  |
| 3        | 230 6326 | 6          | STIFT             | PIN            | CHEVILLE/GOUPILLE | PERNO/PASADOR      |   |     |
| 4        | 230 6327 | 6          | KNOPF             | BUTTON/KNOB    | BOUTON            | BOTON              |   |     |
| 6        | 112 1373 | 2          | GLUEHLAMPE        | LIGHT BULB     | LAMPE A INCANDESC | BOMBILLA           | B 12V 35 W/35DIN72601 GELB<br>8145-6EL8 | 03  |
| 10       | 233 1059 | 2          | SCHUTZKAPPE       | CAP            | CAPUCHON PROTECT  | SOMBRERETE PROTEC- |   |     |
| 14       | 233 5360 | 1          | LEITUNG           | LINE/LEAD      | CONDUCTEUR        | CONDUCTOR          |   |     |
| 15       | 233 5361 | 1          | LEITUNG           | LINE/LEAD      | CONDUCTEUR        | CONDUCTOR          |   |     |
| 16       | 116 9062 | 1          | FLACHSTECKHUELSE  | FEMALE PLUG    | DOILLE PLATE      | HEMBRA ENCHUF-PLAN | B1 H7602                                |     |
| 17       | 116 9436 | 1          | LEITUNGSVERBINDER | WIRE CONNECTOR | CONNECTEUR        | LIGA-TUBERIAS      | F1H 7677                                |     |
| 18       | 116 1085 | 8          | KABELBAND         | CABLE STRAP    | RUBAN PR CABLE    | CINTA ATACABLES    | N 15 H 7672                             |     |
| 20       | 236 3036 | 2          | SCHWEINWERFER     | HEADLIGHT      | PHARE             | FARO               |   |     |
| 21       | 121 0674 | 4          | TUELLE            | GROMMET        | DOUILLE           | FUNDA              | 7 565 H 1                               |     |



SCHEINWERFER - AUBEN  
HEADLAMPS - EXTERNAL  
PHARES - MONTES A L' EXTERIEUR  
FAROS - EXTERIORS

1001-49 500 5431

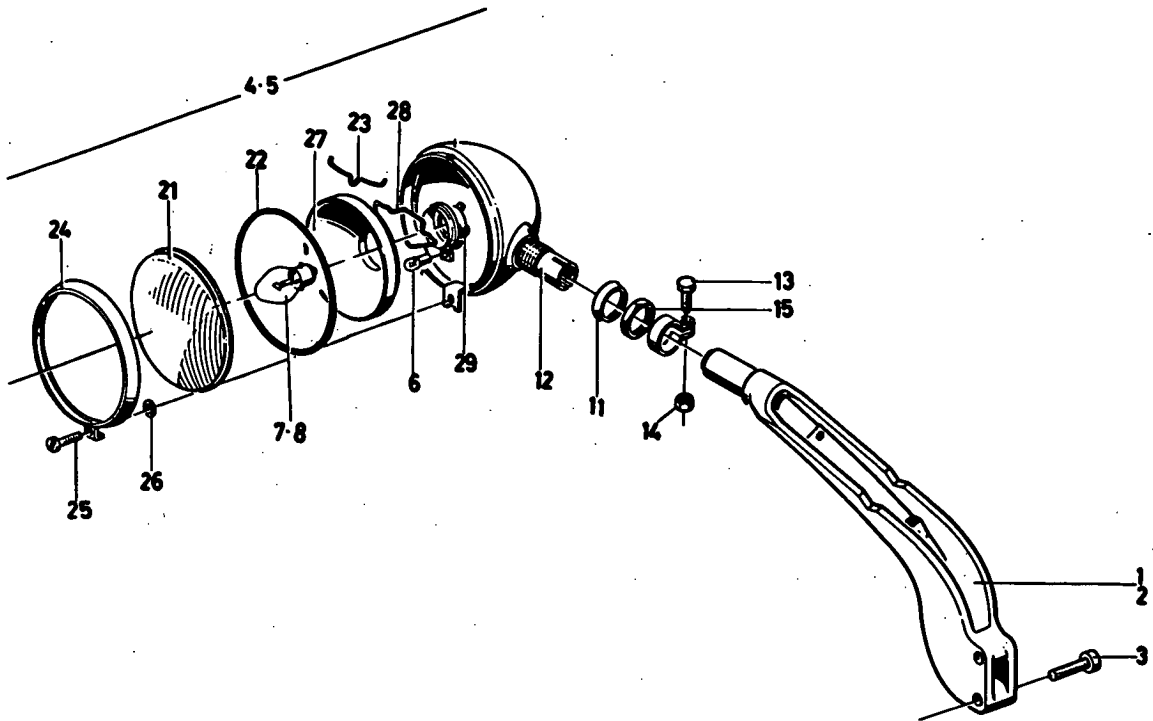

1001-49 500 5431

| Bld. Nr. | Teil-Nr. | Stück-Zahl | Deutsch           | English           | Français          | Español            | Nummer/Bemerkung  | ETK |
|----------|----------|------------|-------------------|-------------------|-------------------|--------------------|---|-----|
| 1        | 230 6958 | 1          | HALTER            | RETAINER          | SUPPORT/PORTEQUIL | SOPORTE            | 8267-RECHTS   |     |
| 2        | 230 6957 | 1          | HALTER            | RETAINER          | SUPPORT/PORTEQUIL | SOPORTE            | 8195-LINKS  |     |
| 3        | 112 3700 | 4          | ZYLINDERSCHRAUBE  | CHEESE-HEAD SCREW | VIS TETE CYLINDR. | TORN-BOZA-CILIND.  | M 8 X 35 DIN 932- 8-8 A4C   |     |
| 4        | 338 8085 | 1          | SCHEINWERFER      | HEADLIGHT         | PHARE             | FARO               | 1125-49-57-10<br>8267-RECHTS 8347 VOLLSTAENDIG<br>MIT POS.11-15-21-29 |     |
| 5        | 338 8086 | 1          | SCHEINWERFER      | HEADLIGHT         | PHARE             | FARO               | 1125-49-57-20<br>8195-LINKS 8347 VOLLSTAENDIG<br>MIT POS.11-15-21-29  |     |
| 6        | 112 1426 | 2          | GLUEHLAMPE        | LIGHT BULB        | LAMPE A INCANDESC | BOMBILLA           | M12V 4 W DIM72601   | 01  |
| 7        | 112 1372 | 2          | GLUEHLAMPE        | LIGHT BULB        | LAMPE A INCANDESC | BOMBILLA           | 8 12V 35 W/35DIN72601   | 01  |
| 8        | 112 1373 | 2          | GLUEHLAMPE        | LIGHT BULB        | LAMPE A INCANDESC | BOMBILLA           | 8 12V 35 W/35DIN72601 GELB  | 01  |
| 11       | 232 4821 | 2          | DRUCKRING         | THRUST RING       | BAGUE DE BUTEE    | ANILLO PRESION.    |   |     |
| 12       | 232 4822 | 2          | KLEHMSTUECK       | CLAMP             | PIECE DE SERRAGE  | PZA-APRIETO        |   |     |
| 13       | 111 1288 | 2          | SECHSKANTSCHRAUBE | HEX-BOLT          | VIS 6 PANS        | TORNILLO HEXAGONAL | M10X 40 DIN 933-M 8-8 A4C   |     |
| 14       | 110 2659 | 2          | SECHSKANTMUTTER   | HEX-NUT           | ECROU 6 PANS      | TUERCA HEXAGONAL   | M10 DIN 934-M 8 A4C   |     |
| 15       | 111 2961 | 2          | SECHSKANTMUTTER   | HEX-NUT           | ECROU 6 PANS      | TUERCA HEXAGONAL   | M80 X1,5 DIN 934-M 8  |     |
| 21       | 232 1190 | 2          | STREUSCHEIBE      | DIFFUSOR          | DIFFUSEUR         | CRISTAL DIFUSOR    |   |     |
| 22       | 232 1225 | 2          | DICHTUNG          | GASKET            | GARNITURE/JOINT   | JUNTA              |   | 01  |
| 23       | 127 6024 | 12         | SPRENGFEDER       | SPRING            | RESSORT A ECARTEN | RESORTE            |   | 01  |
| 24       | 232 1228 | 2          | HALTERING         | RETAINING RING    | BAGUE SUPPORT     | ANILLO SUJECION    |   |     |
| 25       | 110 5526 | 2          | ZYLINDERSCHRAUBE  | CHEESE-HEAD SCREW | VIS TETE CYLINDR. | TORN-BOZA-CILIND.  | M 5 X 35 DIN 84- 4-8-A4C  |     |
| 26       | 232 1229 | 2          | SICHERUNGSSCHEIBE | LOCKING WASHER    | RONDELLE SECURITE | ARANDELA SEGURIDAD |   | 01  |
| 27       | 232 1230 | 2          | REFLEKTOR         | REFLECTOR         | REFLECTEUR        | REFLECTOR          |   | 01  |
| 28       | 127 6020 | 2          | SPANNBUEGEL       | CLAMPING YOKE     | ETRIER SERRAGE    | ESTRIBO FIJACION   |   | 01  |
| 29       | 232 1232 | 2          | LAMPENFASSUNG     | LAMP SOCKET       | DOUILLE D AMPOULE | PORTALAMPARA       |   |     |

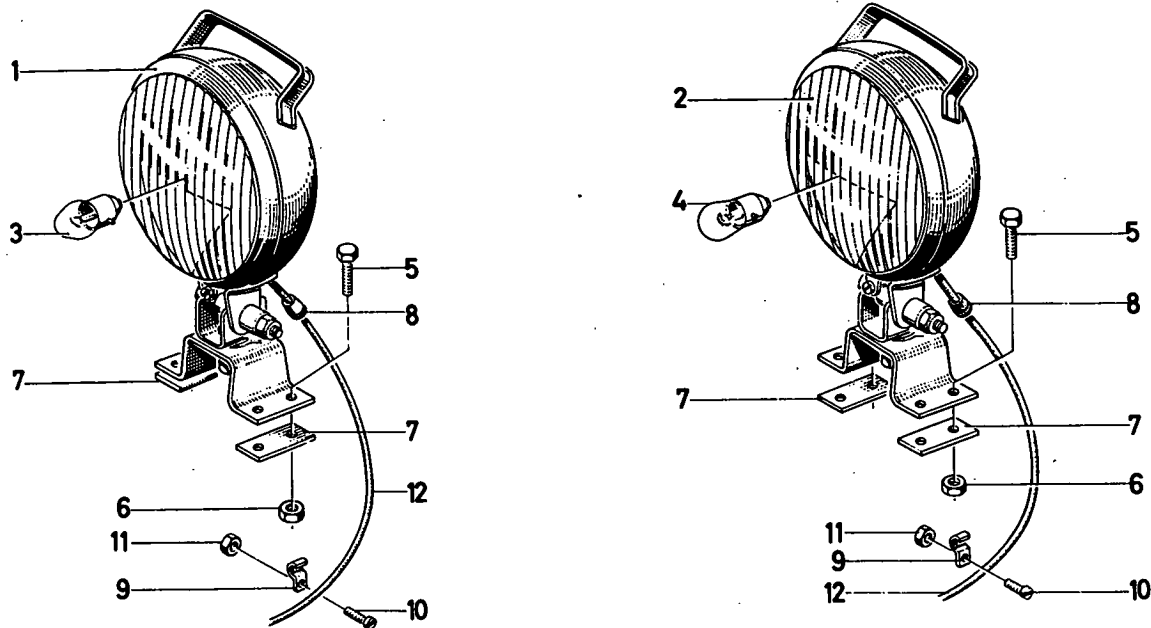

| Bild Nr. | Teile-Nr. | Stück-Zahl | Deutsch           | English          | Français           | Español            | Numer / Bemerkung   | ETK |
|----------|-----------|------------|-------------------|------------------|--------------------|--------------------|---|-----|
| 1        | 338 6499  | TN         | SCHEINWERFER      | HEADLIGHT        | PHARE              | FARO               | 1053-49-19-10<br>8313-TEILNUMMERN-LISTENBLATT<br>1053-49 502 0278 |     |
| 2        | 233 5406  | TN         | SCHEINWERFER      | HEADLIGHT        | PHARE              | FARO               | HALOGEN<br>8313-TEILNUMMERN-LISTENBLATT<br>1053-49 502 0278       |     |
| 3        | 112 1395  | 1          | GLUEHLAMPE        | LIGHT BULB       | LAMPE A INCANDESC  | BOMBILLA           | F 12V 35 W DIN72601   | 01  |
| 4        | 110 2258  | 1          | GLUEHLAMPE        | LIGHT BULB       | LAMPE A INCANDESC  | BOMBILLA           | YC12V 55 W DIN72601   | 01  |
| 5        | 111 2322  | 4          | SECHSKANTSCHRAUBE | HEX-BOLT         | VIS 6 PANS         | TORNILLO HEXAGONAL | M 8 X 20 DIN 933- 8-8-A9C   |     |
| 6        | 111 2824  | 4          | SECHSKANMUTTER    | HEX-NUT          | ECROU 6 PANS       | TUERCA HEXAGONAL   | M 8 DIN 934-M 8 A9C   |     |
| 7        | 339 0246  | 2          | UNTERLAGE         | PAD/BASE         | CALE/SENELLE/SUPP. | BASE/APOYO/ASIENTO | 1153-49-07-05   |     |
| 8        | 116 7421  | 1          | GUMMITUELLE       | RUBBER GROMMET   | GAINE CAOUTCHOUC   | FUNDA CAUCHO       | D 8 X13 X 2 H 2928  |     |
| 9        | 110 1603  | 1          | SCHELLE           | CLIP             | COLLIER            | ABRAZADERA         | 1 X 5DIN72571 VZKC  |     |
| 10       | 111 9629  | 1          | LINSENSCHRAUBE    | FILL.-HEAD SCREW | VIS GOUTTE DE SUIF | TORN.CAB.LENTICUL. | AN4X12DIN 7985- 4-8 VZKC  |     |
| 11       | 111 2796  | 1          | SECHSKANMUTTER    | HEX-NUT          | ECROU 6 PANS       | TUERCA HEXAGONAL   | M 4 DIN 934-M 8 A9C   |     |
| 12       | 233 5403  | 1          | LEITUNG           | LINE/LEAD        | CONDUCTEUR         | CONDUCTEUR         |   |     |

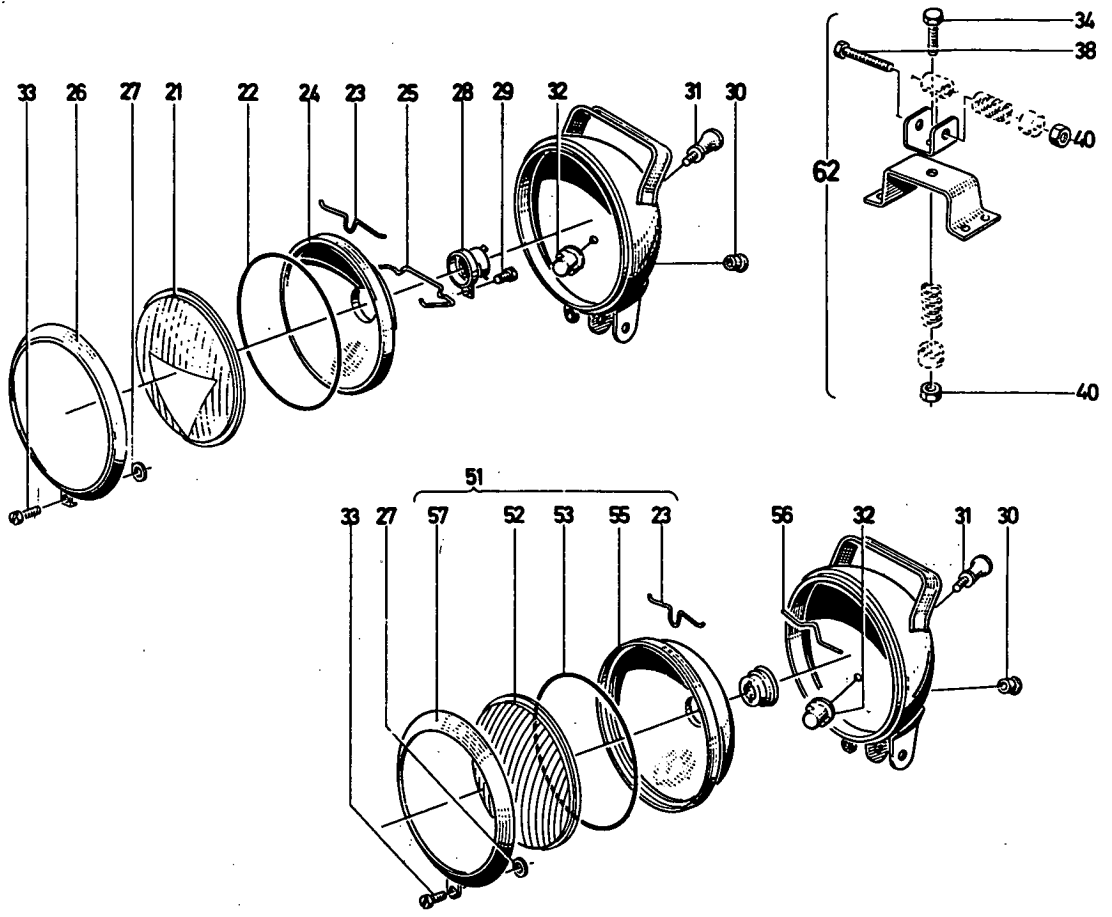

1053-49 502 0278

| Bild Nr. | Teil-Nr. | Stück-Zahl | Deutsch             | English          | Français           | Español            | Nummer/Bemerkung                      | ETK |
|----------|----------|------------|---------------------|------------------|--------------------|--------------------|---------------------------------------|-----|
| 21       | 230 5217 | 1          | STREUSCHEIBE        | DIFFUSOR         | DIFFUSEUR          | CRISTAL DIFUSOR    |                                       |     |
| 22       | 230 5218 | 1          | DICHTUNG            | GASKET           | GARNITURE/JOINT    | JUNTA              |                                       | 01  |
| 23       | 232 1227 | 1          | SPRENGFEDER         | SPRING           | RESSORT A ECARTEN  | RESORTE            |                                       | 01  |
| 24       | 230 5219 | 1          | REFLEKTOR           | REFLECTOR        | REFLECTEUR         | REFLECTOR          |                                       |     |
| 25       | 127 6020 | 1          | SPANNBUEGEL         | CLAMPING YOKE    | ETRIER SERRAGE     | ESTRIBO FIJACION   |                                       | 01  |
| 26       | 230 5220 | 1          | GLASHALTERUNG       | GLASS RETAINER   | SUPPORT DE VERRE   | SUJETA-VIDRIO      |                                       |     |
| 27       | 232 1229 | 1          | SICHERUNGSSCHEIBE   | LOCKING WASHER   | RONDELLE SECURITE  | ARANDELA SEGURIDAD |                                       | 01  |
| 28       | 230 5221 | 1          | LAMPENFASSUNG       | LAMP SOCKET      | BOUILLE D AMPOULE  | PORTALAMPARA       |                                       |     |
| 29       | 235 2348 | 4          | LINSENSCHRAUBE      | FILL-HEAD SCREW  | VIS GOUTTE DE SUIF | TORN.CAB.LENTICUL. |                                       |     |
| 30       | 230 5223 | 1          | TUELLE              | GROMMET          | BOUILLE            | FUNDA              |                                       | 01  |
| 31       | 233 3475 | 1          | KNOPF               | BUTTON/KNOB      | BOUTON             | BOTON              |                                       | 01  |
| 32       | 233 4655 | 1          | SCHUBSCHALTER       | TUMBLE SWITCH    | INTERRUPT POUSSEE  | COMUTAD.BOTON TIR  |                                       | 01  |
| 33       | 110 5669 | 1          | LINSENSCHRAUBE      | FILL-HEAD SCREW  | VIS GOUTTE DE SUIF | TORN.CAB.LENTICUL. | AM 5 X 12 DIN 85- 4.8-A4C             |     |
| 34       | 112 5793 | 1          | SECHSKANTSCHRAUBE   | HEX-BOLT         | VIS 6 PANS         | TORNILLO HEXAGONAL | M10X 40 DIN 931- 8.8-A4C              |     |
| 38       | 112 2524 | 1          | SECHSKANTSCHRAUBE   | HEX-BOLT         | VIS 6 PANS         | TORNILLO HEXAGONAL | M10X1 X 75 DIN 960-M 5.6              |     |
| 40       | 110 8065 | 2          | SECHSKANMUTTER      | HEX-NUT          | ECROU 6 PANS       | TUERCA HEXAGONAL   | M10 DIN 555                           |     |
| 51       | 237 0588 | IP         | SCHWEINWERF-EINSATZ | HEADLIGHT INSERT | OPTIQUE DE PHARE   | ELEMENTO FARO      | HALOSEN<br>B285-SIEME POS.52.53.55.57 |     |
| 52       | 237 0589 | 1          | STREUSCHEIBE        | DIFFUSOR         | DIFFUSEUR          | CRISTAL DIFUSOR    |                                       |     |
| 53       | 237 0572 | 1          | DICHTUNG            | GASKET           | GARNITURE/JOINT    | JUNTA              |                                       | 01  |
| 55       | 237 0573 | 1          | REFLEKTOR           | REFLECTOR        | REFLECTEUR         | REFLECTOR          |                                       |     |
| 56       | 237 0574 | 1          | HALTEFEDER          | RETAINING SPRING | RESORT DE RETENUE  | RESORTE RETENCION  |                                       | 01  |
| 57       | 237 0575 | 1          | GLASHALTERUNG       | GLASS RETAINER   | SUPPORT DE VERRE   | SUJETA-VIDRIO      |                                       |     |
| 62       | 230 5224 | 1          | HALTER              | RETAINER         | SUPPORT/PORTEQUIL  | SOPORTE            |                                       |     |

11-12-13-14

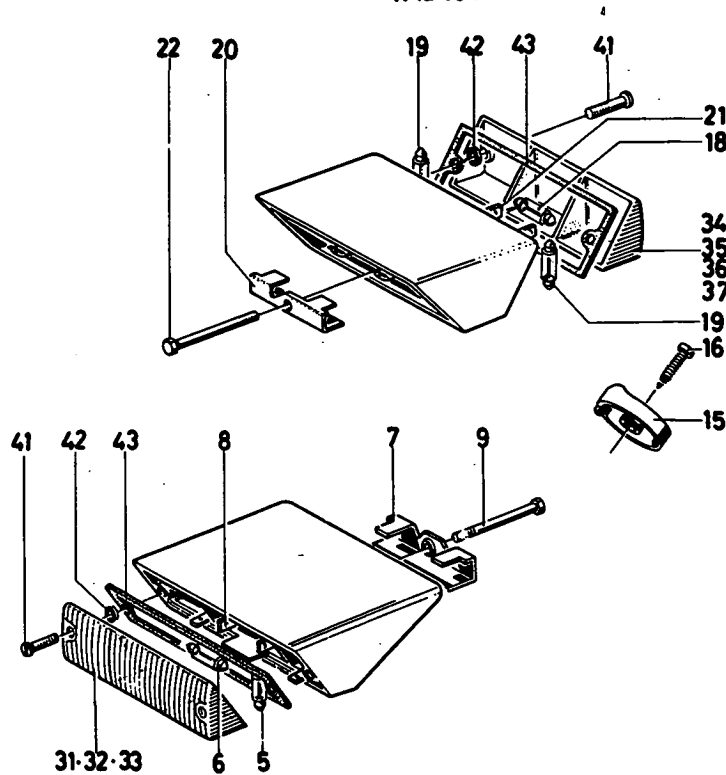

1-2-3

1001-49 500 5434

| Bild Nr. | Teile-Nr. | Stück-Zahl | Deutsch           | English          | Français           | Español            | Numer / Bemerkung   | ETK |
|----------|-----------|------------|-------------------|------------------|--------------------|--------------------|---|-----|
| 1        | 230 6339  | 1          | BLINKLEUCHE       | BLINKER LIGHT    | AMPOULE CLIGNOT.   | LAMP-INTERMITENT.  | B195, LINKS B347VOLLSTÄNDIG MIT POSITION 31,41-43                                 |     |
| 2        | 230 6708  | 1          | BLINKLEUCHE       | BLINKER LIGHT    | AMPOULE CLIGNOT.   | LAMP-INTERMITENT.  | B267 RECHTS B347VOLLSTÄNDIG MIT POSITION 32,41-43                                 |     |
| 3        | 230 6338  | 1          | POSITIONSLEUCHE   | SIDE LIGHT       | FEU DE POSITION    | LAMPARA POSICION   | B198, LINKS UND RECHTS B211, MIT POSITION 33,41-43                                |     |
| 5        | 112 1438  | 4          | GLUEHLAMPE        | LIGHT BULB       | LAMPE A INCANDESC  | BOMBILLA           | K 12V 18 W DIN72601   | 01  |
| 6        | 112 1444  | 2          | GLUEHLAMPE        | LIGHT BULB       | LAMPE A INCANDESC  | BOMBILLA           | L 12V 5 W DIN72601  | 01  |
| 7        | 230 6343  | 2          | STUETZBUEGEL      | SUPPORT          | ETRIER SUPPORT     | ESTRIBO APOYO      | B346, VORN  |     |
| 8        | 116 9070  | 2          | VERTEILER         | DISTRIBUTOR      | DISTRIBUTEUR       | DISTRIBUIDOR/DELCO | 1 BC5 H 7602  |     |
| 9        | 110 1940  | 2          | SECHSKANTSCHRAUBE | HEX-BOLT         | VIS 6 PANS         | TORNILLO HEXAGONAL | M 6x 100 DIN 931-M 6-8 A4C  |     |
| 11       | 230 6632  | 1          | BREMSLEUCHE       | STOP LIGHT       | FEU DE STOP        | LUZ FRENADO        | B293, SCHLUSS-BREMS-BLINK-KENNZEICHENLEUCHE B347, VOLLSTÄNDIG MIT POSIT. 34,41-43 |     |
| 12       | 230 6631  | 1          | BREMSLEUCHE       | STOP LIGHT       | FEU DE STOP        | LUZ FRENADO        | B294, SCHLUSS-BREMS-BLINKLEUCHE B347, VOLLSTÄNDIG MIT POS. 35,41-43               |     |
| 13       | 230 6336  | 1          | BREMSLEUCHE       | STOP LIGHT       | FEU DE STOP        | LUZ FRENADO        | B295, SCHLUSS-BREMS-KENNZEICHENLEUCHE B347, VOLLSTÄNDIG MIT POSIT. 36,41-43       |     |
| 14       | 230 6337  | 1          | BREMSLEUCHE       | STOP LIGHT       | FEU DE STOP        | LUZ FRENADO        | B296, SCHLUSS-BREMSLEUCHE B347, VOLLSTÄNDIG MIT POSIT. 37,41-43                   |     |
| 15       | 230 6341  | 1          | AUFLAGE           | SUPPORT          | SUPPORT            | APOYO              |   |     |
| 16       | 110 1505  | 1          | LINSENSCHRAUBE    | FILL.-HEAD SCREW | VIS GOUTTE DE SUIF | TORN-CAB-LENTICUL. | B 4,5x32 DIN 7981 VZKC  |     |
| 18       | 112 1444  | 2          | GLUEHLAMPE        | LIGHT BULB       | LAMPE A INCANDESC  | BOMBILLA           | L 12V 5 W DIN72601  | 01  |

| Stk<br>Nr. | Teil-Nr. | Stück-<br>Zahl | Deutsch           | English           | Francés           | Español            | Nummer/Bemerkung                   | ETK |
|------------|----------|----------------|-------------------|-------------------|-------------------|--------------------|------------------------------------|-----|
| 19         | 112 1438 | 4              | GLUEHLAMPE        | LIGHT BULB        | LAMPE A INCANDESC | BOMBILLA           | K 12V 18 W DIN72601                | 01  |
| 20         | 230 6342 | 2              | STUETZBUEGEL      | SUPPORT           | ETRIER SUPPORT    | ESTRIBO APOYO      | B150-HINTEN                        |     |
| 21         | 116 9070 | 2              | VERTEILER         | DISTRIBUTOR       | DISTRIBUTEUR      | DISTRIBUIDOR/BELCO | 1 80% H 7602                       |     |
| 22         | 110 1997 | 2              | SECHSKANTSCHRAUBE | HEX-BOLT          | VIS 6 PANS        | TORNILLO HEXAGONAL | M 6X 95 DIN 931- 8-8-A9C           |     |
| 31         | 233 2199 | 1              | LICHTSCHEIBE      | DANE              | VITRE LUMINEUX    | CRISTAL ALUMBRADO  | B195-LINKS<br>B367-ZU POSITION 1.  |     |
| 32         | 233 2200 | 1              | LICHTSCHEIBE      | DANE              | VITRE LUMINEUX    | CRISTAL ALUMBRADO  | B267-RECHTS<br>B367-ZU POSITION 2. |     |
| 33         | 233 2204 | 1              | LICHTSCHEIBE      | DANE              | VITRE LUMINEUX    | CRISTAL ALUMBRADO  | B367-ZU POSITION 3.                |     |
| 34         | 233 2197 | 1              | LICHTSCHEIBE      | DANE              | VITRE LUMINEUX    | CRISTAL ALUMBRADO  | B367-ZU POSITION 11.               |     |
| 35         | 233 2194 | 1              | LICHTSCHEIBE      | DANE              | VITRE LUMINEUX    | CRISTAL ALUMBRADO  | B367-ZU POSITION 12.               |     |
| 36         | 233 2206 | 1              | LICHTSCHEIBE      | DANE              | VITRE LUMINEUX    | CRISTAL ALUMBRADO  | B367-ZU POSITION 13.               |     |
| 37         | 233 2205 | 1              | LICHTSCHEIBE      | DANE              | VITRE LUMINEUX    | CRISTAL ALUMBRADO  | B367-ZU POSITION 14.               |     |
| 41         | 112 7573 | 8              | ZYLINDERSCHRAUBE  | CHEESE-HEAD SCREW | VIS TETE CYLINDR. | TORN.CBZA.CILIND.  | B 4,2X13 DIN 7971 VZKC             |     |
| 42         | 233 2195 | 8              | GUMMISCHEIBE      | RUBBER DISC       | DISQUE EN CAOUTCH | DISCO/ARANDELA     |                                    | 01  |
| 43         | 233 2196 | 4              | DICHTUNG          | GASKET            | GARNITURE/JOINT   | JUNTA              |                                    | 01  |

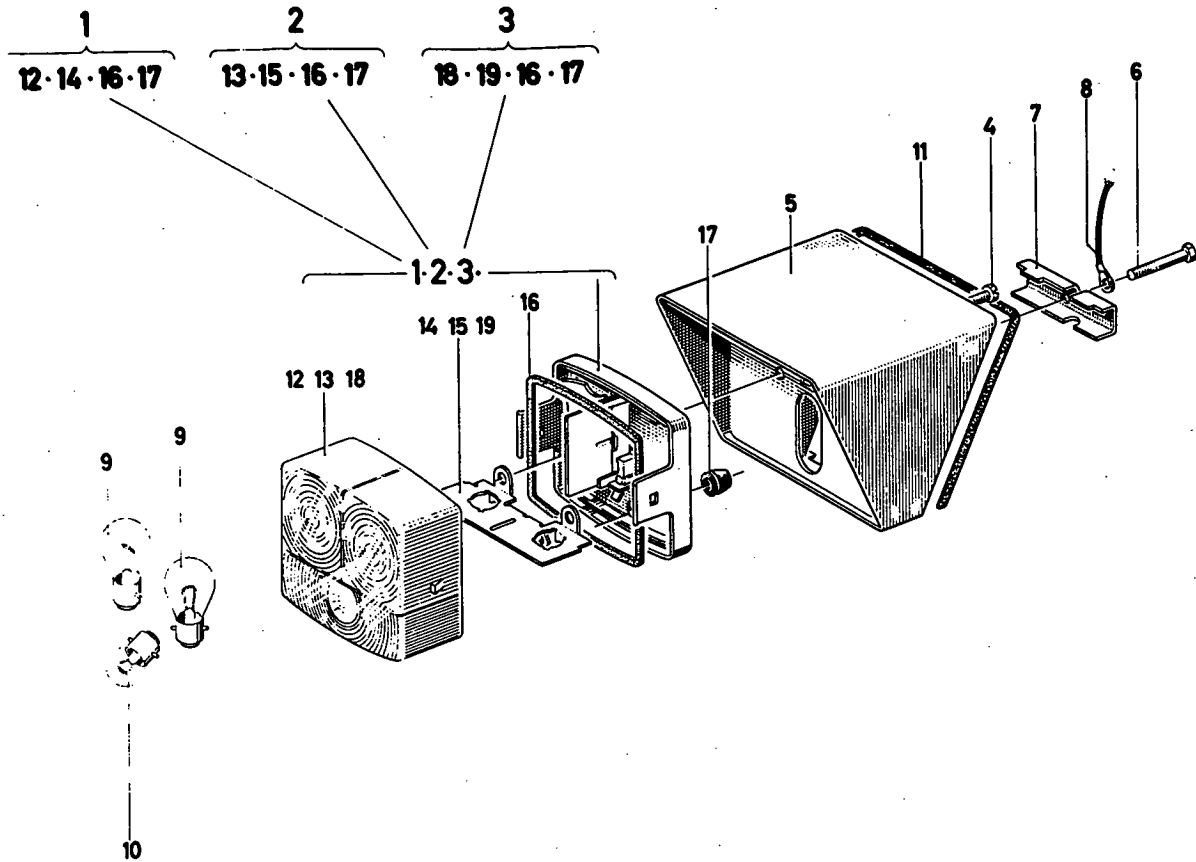

| Bild Nr. | Teil-Nr. | Stück-Zahl | Deutsch           | English          | Français           | Español            | 1001-49 502 0181<br>Nummer/Bemerkung | ETK |
|----------|----------|------------|-------------------|------------------|--------------------|--------------------|--------------------------------------|-----|
| 1        | 237 7448 | 1          | LEUCHE-BLPO       | LIGHTS           | COMB-CL/PO5        | LUZ INTERNIT/POSIC | B195-LINKS                           |     |
| 2        | 237 7450 | 1          | LEUCHE-BLPO       | LIGHTS           | COMB-CL/PO5        | LUZ-INTERNIT/POSIC | B267-RECHTS                          |     |
| 3        | 237 7452 | 2          | POSITIONSLEUCHE   | SIDE LIGHT       | FEU DE POSITION    | LAMPARA POSICION   | B198-LINKS U-RECHTS                  |     |
| 4        | 112 4043 | 2          | LINSENSCHRAUBE    | FILL.-HEAD SCREW | VIS GOUTTE DE SUIF | TORN-CAB-LENTICUL. | AN 5X20 DIN 7985-4.8 A4C             |     |
| 5        | 237 5799 | 1          | ZWISCHENSTUECK    | ADAPTER          | PIECE INTERCALAIRE | PIEZA INTERMEDIA   |                                      |     |
| 6        | 110 1440 | 1          | SECHSKANTSCHRAUBE | HEX-BOLT         | VIS 6 PANS         | TORNILLO HEXAGONAL | M6X100 DIN 931-M6.8-A4C              |     |
| 7        | 230 6343 | 1          | STUETZE           | SUPPORT          | SUPPORT/APPUI      | APOYO              |                                      |     |
| 8        | 237 7453 | 1          | LEITUNG           | LINE/LEAD        | CONDUCTEUR         | CONDUCTOR          |                                      |     |
| 9        | 110 2550 | 1          | GLUEHLAMPE        | LIGHT BULB       | LAMPE A INCANDESC  | BOMBILLA           | R12V 21 W DIN72601                   | 01  |
| 10       | 112 1401 | 1          | GLUEHLAMPE        | LIGHT BULB       | LAMPE A INCANDESC  | BOMBILLA           | 6 12V 10W DIN 72601                  | 01  |
| 11       | 139 0702 | MTR        | KLEMMPROFIL       | CLAMPING SECTION | PROFIL DE SERRAGE  | PERFIL APRIETO     | 13.5X10 KUNSTSTOFF N-STAHLEIN        |     |
| 12       | 238 1650 | 1          | LICHTSCHEIBE      | DANE             | VITRE LUMINEUX     | CRISTAL ALUMBRADO  |                                      |     |
| 13       | 238 1651 | 1          | LICHTSCHEIBE      | DANE             | VITRE LUMINEUX     | CRISTAL ALUMBRADO  |                                      |     |
| 14       | 238 1652 | 1          | LAMPENFASSUNG     | LAMP SOCKET      | DOUILLE D AMPOULE  | PORTALAMPARA       |                                      |     |
| 15       | 238 1653 | 1          | LAMPENFASSUNG     | LAMP SOCKET      | DOUILLE D AMPOULE  | PORTALAMPARA       |                                      |     |
| 16       | 238 1654 | 1          | DICHTUNG          | GASKET           | GARNITURE/JOINT    | JUNTA              |                                      | 01  |
| 17       | 237 1927 | 1          | TUELLE            | GRONNET          | DOUILLE            | FUNDA              |                                      |     |
| 18       | 238 1659 | 1          | LICHTSCHEIBE      | DANE             | VITRE LUMINEUX     | CRISTAL ALUMBRADO  |                                      |     |
| 19       | 238 1664 | 1          | LAMPENFASSUNG     | LAMP SOCKET      | DOUILLE D AMPOULE  | PORTALAMPARA       |                                      |     |



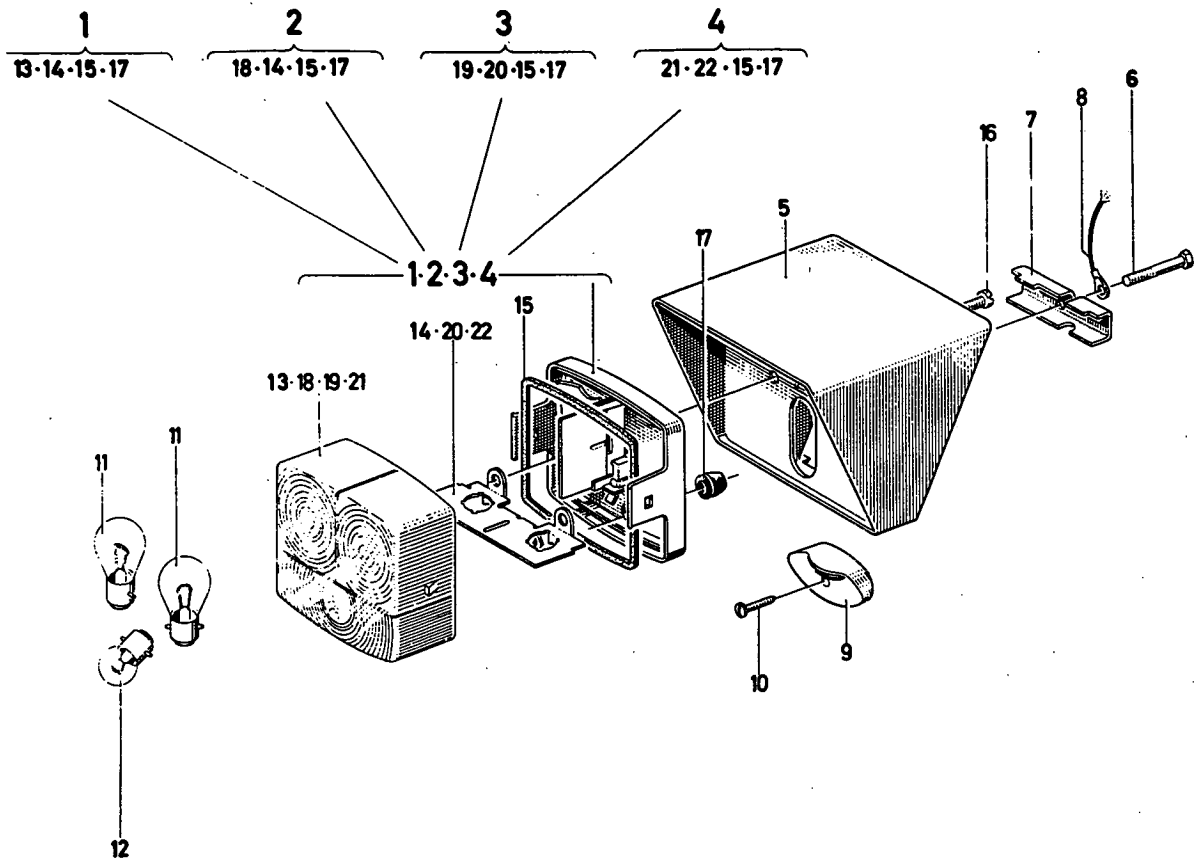

| Bld Nr. | Teile-Nr. | Stück-Zahl | Deutsch            | English          | Français           | Español            | 1001-49 502 0182<br>Nummer/Bemerkung         | ETK |
|---------|-----------|------------|--------------------|------------------|--------------------|--------------------|--|-----|
| 1       | 237 7139  | 1          | LEUCHTE-SBBLK      | LIGHTS           | COMB-ST-AR-CLI-PLA | LUZ COLA UNIVERS-  | 8293-SCHLUSS-BREMS-BLINK-KENNZEICHEN-LEUCHTE |     |
| 2       | 237 7137  | 1          | LEUCHTE-SBBLK      | LIGHTS           | COMB-ST-AR-CLI-PLA | LUZ COLA UNIVERS-  | 8294-SCHLUSS-BREMS-BLINK-LEUCHTE             |     |
| 3       | 237 7135  | 1          | SCHLUSSLEUCHTE     | TAIL LIGHT       | FEU ARRIERE        | LUZ PILOTO/DE COLA | 8295-SCHLUSS-BREMS-KENNZEICHEN-LEUCHTE       |     |
| 4       | 237 7133  | 1          | SCHLUSSLEUCHTE     | TAIL LIGHT       | FEU ARRIERE        | LUZ PILOTO/DE COLA | 8296-SCHLUSS-BREMS-LEUCHTE                   |     |
| 5       | 238 7528  | 1          | ZWISCHENSTUECK     | ADAPTER          | PIECE INTERCALAIRE | PIEZA INTERMEDIA   |  |     |
| 6       | 112 6975  | 1          | SECHSKANTSCHRAUBE  | HEX-BOLT         | VIS 6 PANS         | TORNILLO HEXAGONAL | M6X70 DIN 931-8-8-A9C                        |     |
| 7       | 230 6342  | 1          | STUETZE            | SUPPORT          | SUPPORT/APPUY      | APOYO              |  |     |
| 8       | 237 7453  | 1          | LEITUNG            | LINE/LEAD        | CONDUCTEUR         | CONDUCTOR          |  |     |
| 9       | 230 6343  | 1          | AUFLAGE            | SUPPORT          | SUPPORT            | APOYO              |  |     |
| 10      | 110 1505  | 1          | LINSENBL.-SCHRAUBE | FILL.-HEAD SCREW | VIS GOUTTE DE SUIF | TORN-LENTICULAR    | 84-8X32 DIN 7981 VZKC                        |     |
| 11      | 110 2550  | 2          | GLUEHLAMPE         | LIGHT BULB       | LAMPE A INCANDESC  | BOMBILLA           | RL12V 21 W DIN 72601                         | 01  |
| 12      | 112 1409  | 1          | GLUEHLAMPE         | LIGHT BULB       | LAMPE A INCANDESC  | BOMBILLA           | 6 12V 10W DIN 72603                          | 01  |
| 13      | 238 1663  | 1          | LICHTSCHEIBE       | DANE             | VITRE LUMINEUX     | CRISTAL ALUMBRADO  |  |     |
| 14      | 238 1664  | R 1        | LAMPENFASSUNG      | LAMP SOCKET      | DOUILLE D ANPOULE  | PORTALAMPARA       |  |     |
| 15      | 238 1654  | 1          | DICHTUNG           | GASKET           | GARNITURE/JOINT    | JUNTA              |  | 01  |
| 16      | 112 4043  | 2          | LINSENSCHRAUBE     | FILL.-HEAD SCREW | VIS GOUTTE DE SUIF | TORN-CAB-LENTICUL. | M6 5X20 DIN 7985-4-8 ANC                     |     |
| 17      | 237 1427  | 1          | TUELLE             | GROMMET          | DOUILLE            | FUNDA              |  |     |
| 18      | 238 1665  | R 1        | LICHTSCHEIBE       | DANE             | VITRE LUMINEUX     | CRISTAL ALUMBRADO  |  |     |
| 19      | 238 1663  | 1          | LICHTSCHEIBE       | DANE             | VITRE LUMINEUX     | CRISTAL ALUMBRADO  |  |     |
| 20      | 238 1653  | 1          | LAMPENFASSUNG      | LAMP SOCKET      | DOUILLE D ANPOULE  | PORTALAMPARA       |  |     |
| 21      | 238 1657  | 1          | LICHTSCHEIBE       | DANE             | VITRE LUMINEUX     | CRISTAL ALUMBRADO  |  |     |
| 22      | 238 1652  | 1          | LAMPENFASSUNG      | LAMP SOCKET      | DOUILLE D ANPOULE  | PORTALAMPARA       |  |     |

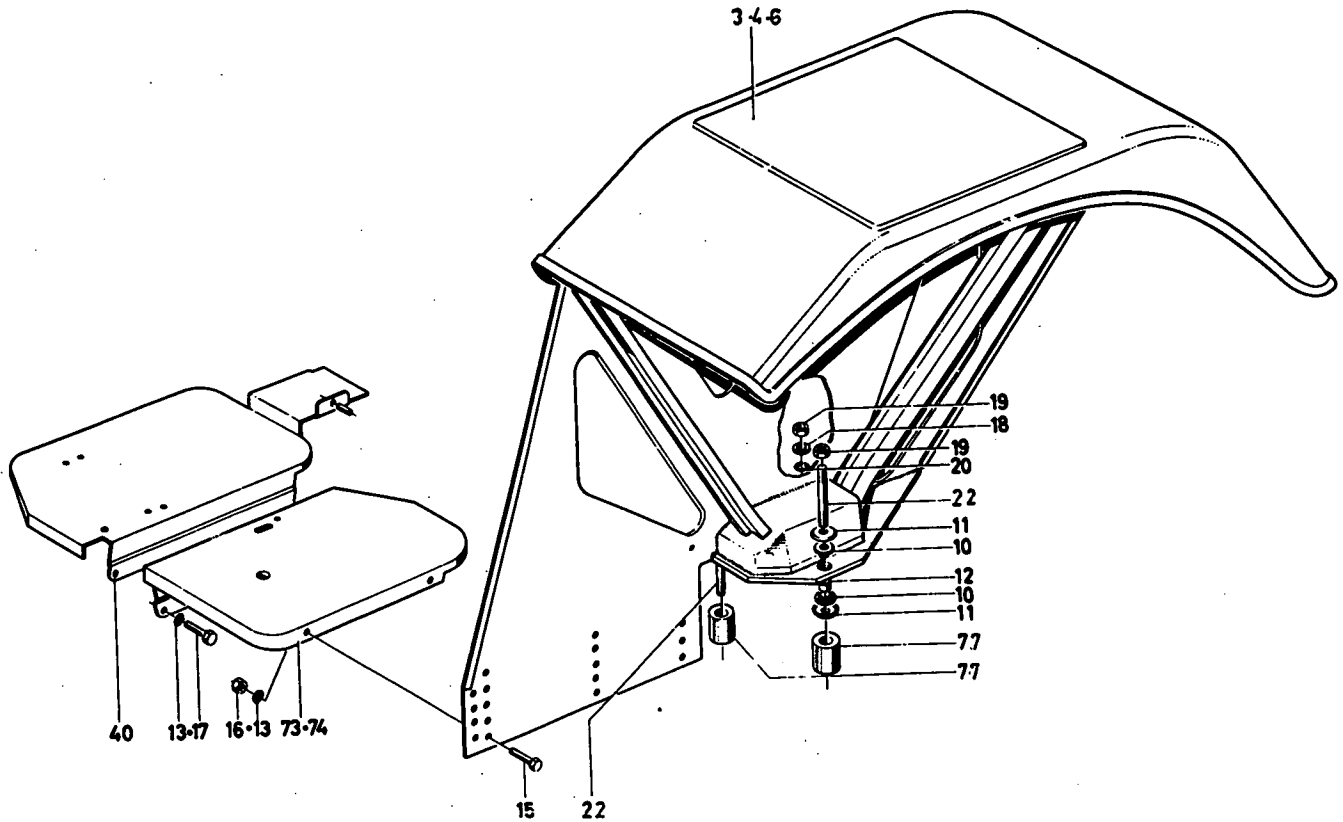

1001-51 500 4231

| Bild Nr. | Teil-Nr. | Stück-Zahl | Deutsch           | English         | Français           | Español            | Nummer/Bemerkung                     | ETK |
|----------|----------|------------|-------------------|-----------------|--------------------|--------------------|--------------------------------------|-----|
| 3        | 230 4946 | 1          | KOTFLUEGEL        | MUDGUARD        | GARDE-BOUE         | GUARDABARROS       | 8195-LINKS                           |     |
| 4        | 230 4947 | 1          | KOTFLUEGEL        | MUDGUARD        | GARDE-BOUE         | GUARDABARROS       | 8267-RECHTS                          |     |
| 6        | 232 2983 | 1          | KOTFLUEGEL        | MUDGUARD        | GARDE-BOUE         | GUARDABARROS       | 8195-LINKS<br>8009-ALLRADAUSFUEHRUNG |     |
| 10       | 338 9709 | 12         | RUNDGUMMIRING     | O-SEAL          | ANNEAU TORIQUE     | ANILLO GOMA REDOND | 1151-51-04-42                        |     |
| 11       | 338 9468 | 12         | TELLER            | PLATE           | CUVETTE            | PLATO              | 1145-51-01-36                        |     |
| 12       | 338 9469 | 6          | ABSTANDROHR       | SPACER TUBE     | TUBE ECARTEMENT    | TUBO DISTANCIARIO  | 1145-51-01-37                        |     |
| 13       | 110 1492 | 8          | ZAHNSCHEIBE       | TOOTHED WASHER  | RONDELLE DENTEE    | ARANDELA DENTADA   | A 8-2DIN 6797 VZKC                   |     |
| 15       | 111 2305 | 4          | SECHSKANTSCHRAUBE | HEX-BOLT        | VIS 6 PANS         | TORNILLO HEXAGONAL | M 8X 15 DIN 933- 8-8-A4C             |     |
| 16       | 111 2829 | 4          | SECHSKANTMUTTER   | HEX-NUT         | ECROU 6 PANS       | TUERCA HEXAGONAL   | M 8 DIN 934-M 8 A4C                  |     |
| 17       | 111 2299 | 4          | SECHSKANTSCHRAUBE | HEX-BOLT        | VIS 6 PANS         | TORNILLO HEXAGONAL | M 8X 12 DIN 933- 8-8-A4C             |     |
| 18       | 110 7110 | 1          | SCHEIBE           | DISC/PANE/PLATE | RONDELLE/DISQUE    | DISCO              | A13 DIN 125-ST-A4C                   |     |
| 19       | 111 2858 | 6          | SECHSKANTMUTTER   | HEX-NUT         | ECROU 6 PANS       | TUERCA HEXAGONAL   | M12 DIN 934-M 8 A4C                  |     |
| 20       | 111 7875 | 1          | ZAHNSCHEIBE       | TOOTHED WASHER  | RONDELLE DENTEE    | ARANDELA DENTADA   | A14-SDIN 6797 A4C                    |     |
| 22       | 110 1932 | 6          | STIFTSCHRAUBE     | STUD            | GOUJON             | ESPARRAGO          | AM12X 70 DIN 939- 8-8 VZKC           |     |
| 40       | 230 4987 | 1          | BODENBLECH        | BOTTOM PLATE    | TOLE DE FOND       | CHAPA PISO         | 8267-RECHTS                          |     |
| 73       | 233 0309 | 1          | BODENBLECH        | BOTTOM PLATE    | TOLE DE FOND       | CHAPA PISO         | 8195-LINKS                           |     |
| 74       | 233 0305 | 1          | BODENBLECH        | BOTTOM PLATE    | TOLE DE FOND       | CHAPA PISO         | 8195-LINKS<br>8009-ALLRADAUSFUEHRUNG |     |
| 77       | 233 4523 | 6          | ZWISCHENSTUECK    | ADAPTER         | PIECE INTERCALAIRE | PIEZA INTERMEDIA   |                                      |     |

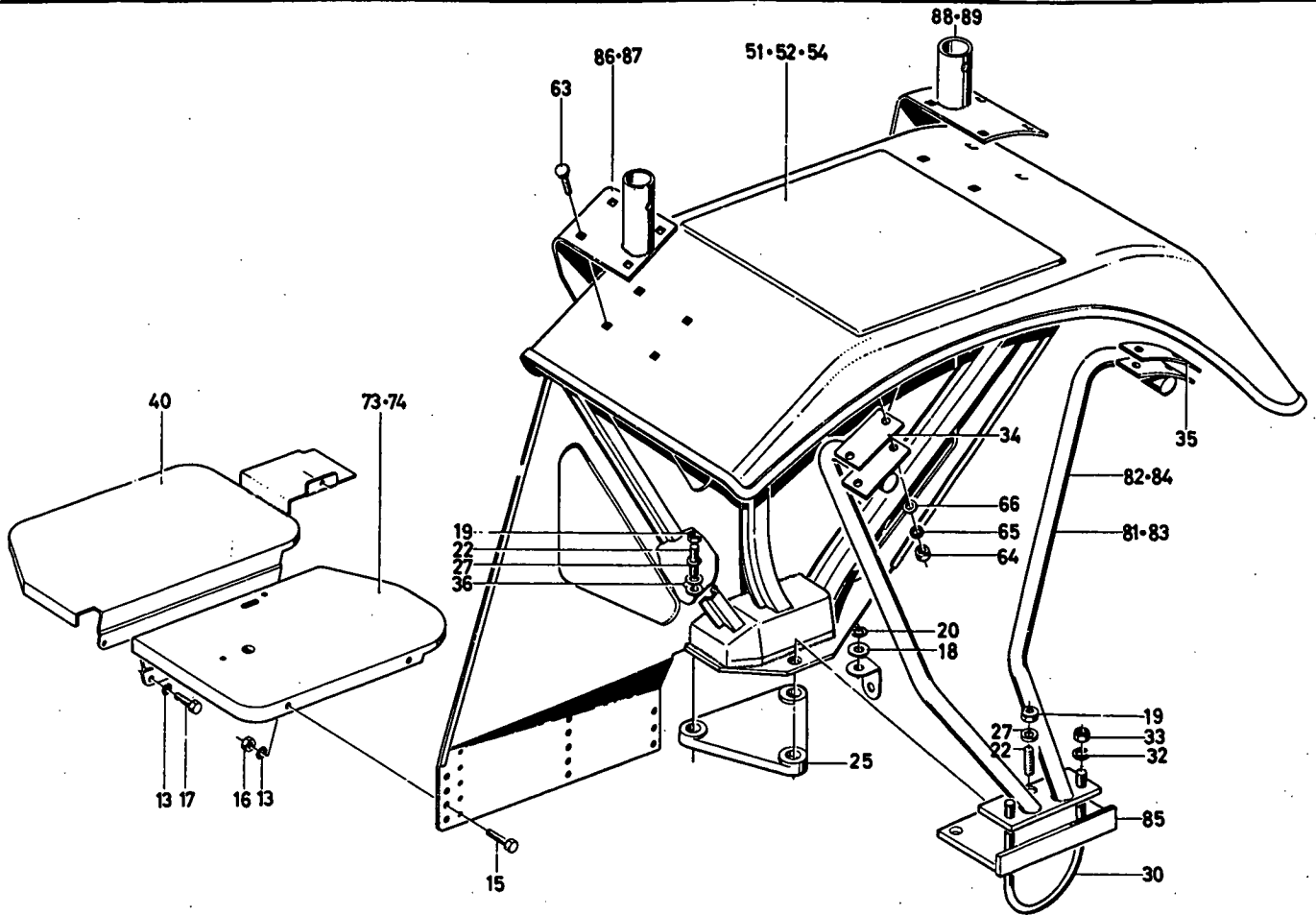

1001-51 500 4232

| Bild Nr. | Teile-Nr. | Stück-Zahl | Deutsch           | English           | Français           | Español            | Nummer/Bemerkung           | ETK |
|----------|-----------|------------|-------------------|-------------------|--------------------|--------------------|----------------------------|-----|
| 13       | 110 1492  | 8          | ZAHNSCHEIBE       | TOOTHED WASHER    | RONDELLE DENTEE    | ARANDELA DENTADA   | A 8,2DIN 6797 VZKC         |     |
| 15       | 111 2305  | 4          | SECHSKANTSCHRAUBE | HEX-BOLT          | VIS 6 PANS         | TORNILLO HEXAGONAL | M 8X 15 DIN 933- 8-8-A4C   |     |
| 16       | 111 2624  | 4          | SECHSKANTMUTTER   | HEX-NUT           | ECROU 6 PANS       | TUERCA HEXAGONAL   | M 8 DIN 934-M 8 A4C        |     |
| 17       | 111 2299  | 4          | SECHSKANTSCHRAUBE | HEX-BOLT          | VIS 6 PANS         | TORNILLO HEXAGONAL | M 8X 12 DIN 933- 8-8-A4C   |     |
| 18       | 110 7110  | 1          | SCHEIBE           | DISC/PANE/PLATE   | RONDELLE/DISQUE    | DISCO              | A13 DIN 125-ST-A4C         |     |
| 19       | 111 2858  | 6          | SECHSKANTMUTTER   | HEX-NUT           | ECROU 6 PANS       | TUERCA HEXAGONAL   | M12 DIN 934-M 8 A4C        |     |
| 20       | 111 7875  | 1          | ZAHNSCHEIBE       | TOOTHED WASHER    | RONDELLE DENTEE    | ARANDELA DENTADA   | A14,5DIN 6797 A4C          |     |
| 22       | 110 1432  | 6          | STIFTSCHRAUBE     | STUD              | GOUJON             | ESPARRAGO          | AM12X 70 DIN 934- 8-8 VZKC |     |
| 25       | 230 9120  | 2          | ABSTANDSTUECK     | SPACER            | ENTRETOISE         | PIEZA DISTANCIARIA | 27 HOCH                    |     |
| 27       | 110 7289  | 5          | FEDERSCHEIBE      | SPRING WASHER     | RONDELLE ELASTIQUE | ARANDELA ELASTICA  | B12 DIN 137 VZKC           |     |
| 30       | 230 4958  | 2          | BUEGELSCHRAUBE    | U-BOLT            | VIS/BOULON EN U    | TORNILLO ASA       |                            |     |
| 32       | 110 2602  | 4          | FEDERRING         | SPRING LOCKWASHER | RONDELLE GROWER    | ARANDELA ELASTICA  | A 14 DIN 128 A4C           |     |
| 33       | 111 2874  | 4          | SECHSKANTMUTTER   | HEX-NUT           | ECROU 6 PANS       | TUERCA HEXAGONAL   | M14 DIN 934-M 8 A4C        |     |
| 34       | 230 4980  | 4          | BEILAGE           | SHIM              | CALE               | SUPLEMENTO         |                            |     |
| 35       | 230 4981  | 4          | BEILAGE           | SHIM              | CALE               | SUPLEMENTO         |                            |     |
| 36       | 110 3252  | 7          | SCHLEIFE          | DISC/PANE/PLATE   | RONDELLE/DISQUE    | DISCO              | R14 DIN 440-A4C            |     |
| 40       | 230 4987  | 1          | BODENBLECH        | BOTTOM PLATE      | TOLE DE FOND       | CHAPA PISO         | B267,RECHTS                |     |
| 51       | 232 3082  | 1          | KOTFLUEGEL        | MUDGUARD          | GARDE-BOUE         | GUARDABARROS       | B195,LINKS                 |     |
| 52       | 232 3083  | 1          | KOTFLUEGEL        | MUDGUARD          | GARDE-BOUE         | GUARDABARROS       | B267,RECHTS                |     |
| 54       | 232 3081  | 1          | KOTFLUEGEL        | MUDGUARD          | GARDE-BOUE         | GUARDABARROS       | B195,LINKS<br>B009,ALLRAD  |     |
| 63       | 110 3420  | 20         | SCHRAUBE          | SCREW/BOLT        | VIS/BOULON         | TORNILLO           | M10X 30 DIN 603 A4C        |     |
| 64       | 110 2659  | 20         | SECHSKANTMUTTER   | HEX-NUT           | ECROU 6 PANS       | TUERCA HEXAGONAL   | M10 DIN 934-M 8 A4C        |     |
| 65       | 116 9674  | 20         | SICHERUNGSBLECH   | LOCKING PLATE     | TOLE DE SECURITE   | CHAPA SEGURIDAD    | 10 H 2203                  |     |

| Bld Nr. | Teile-Nr. | Stück-Zahl | Deutsch           | English          | Français           | Español            | Nummer/Bemerkung                     | ETK |
|---------|-----------|------------|-------------------|------------------|--------------------|--------------------|--------------------------------------|-----|
| 66      | 110 3990  | 20         | SCHEIBE           | DISC/PANE/PLATE  | RONDELLE/DISQUE    | DISCO              | R11.5BIN 490-A4C                     |     |
| 73      | 233 0304  | 1          | BODENBLECH        | BOTTOM PLATE     | TOLE DE FOND       | CHAPA PISO         | 8195-LINKS                           |     |
| 74      | 233 0305  | 1          | BODENBLECH        | BOTTOM PLATE     | TOLE DE FOND       | CHAPA PISO         | 8195-LINKS<br>8009-ALLRADAUSSUEHRUNG |     |
| 81      | 233 1132  | 1          | SCHUTZRAHMEN      | SAFETY FRAME     | CADRE PROTECTEUR   | BASTIDOR PROTECC.  | 8195-LINKS                           |     |
| 82      | 233 1133  | 1          | SCHUTZRAHMEN      | SAFETY FRAME     | CADRE PROTECTEUR   | BASTIDOR PROTECC.  | 8267-RECHTS                          |     |
| 83      | 232 3005  | 1          | KOTFLUEGELSTUETZE | MUDGUARD SUPPORT | SUPP DE GARDE-BOUE | APOYO GUARDABARROS |                                      |     |
| 84      | 232 3006  | 1          | KOTFLUEGELSTUETZE | MUDGUARD SUPPORT | SUPP DE GARDE-BOUE | APOYO GUARDABARROS |                                      |     |
| 85      | 230 4962  | 2          | UNTERLEGSCHNEIBE  | WASHER           | RONDELLE           | ARANDELA CALCE     |                                      |     |
| 86      | 233 1140  | 1          | KONSOLE           | BRACKET/CONSOLE  | CONSOLE            | CONSOLA            | 8348-VORN-LINKS                      |     |
| 87      | 233 1141  | 1          | KONSOLE           | BRACKET/CONSOLE  | CONSOLE            | CONSOLA            | 8349-VORN-RECHTS                     |     |
| 88      | 233 1138  | 1          | KONSOLE           | BRACKET/CONSOLE  | CONSOLE            | CONSOLA            | 8151-HINTEN-LINKS                    |     |
| 89      | 233 1139  | 1          | KONSOLE           | BRACKET/CONSOLE  | CONSOLE            | CONSOLA            | 8152-HINTEN-RECHTS                   |     |



HINTERE KOTFLÜGEL FÜR SCHUTZRAHMEN · SCHEIBEN · TROMMELBREMSE  
 REAR MUDGUARDS FOR SAFETY FRAME · DISC BRAKES · DRUM BRAKE  
 GARDE-BOUE AR POUR ADAPTAT. CADRE DE PROTECTION · FREIN A DISQUE · FREIN DE TAMBOUR  
 GUARDABARR. TRASER. PARA BASTIDOR SALVAVIDAS · FRENO DE DISCO · TAMBOUR FRENO

1004-51 502 0170

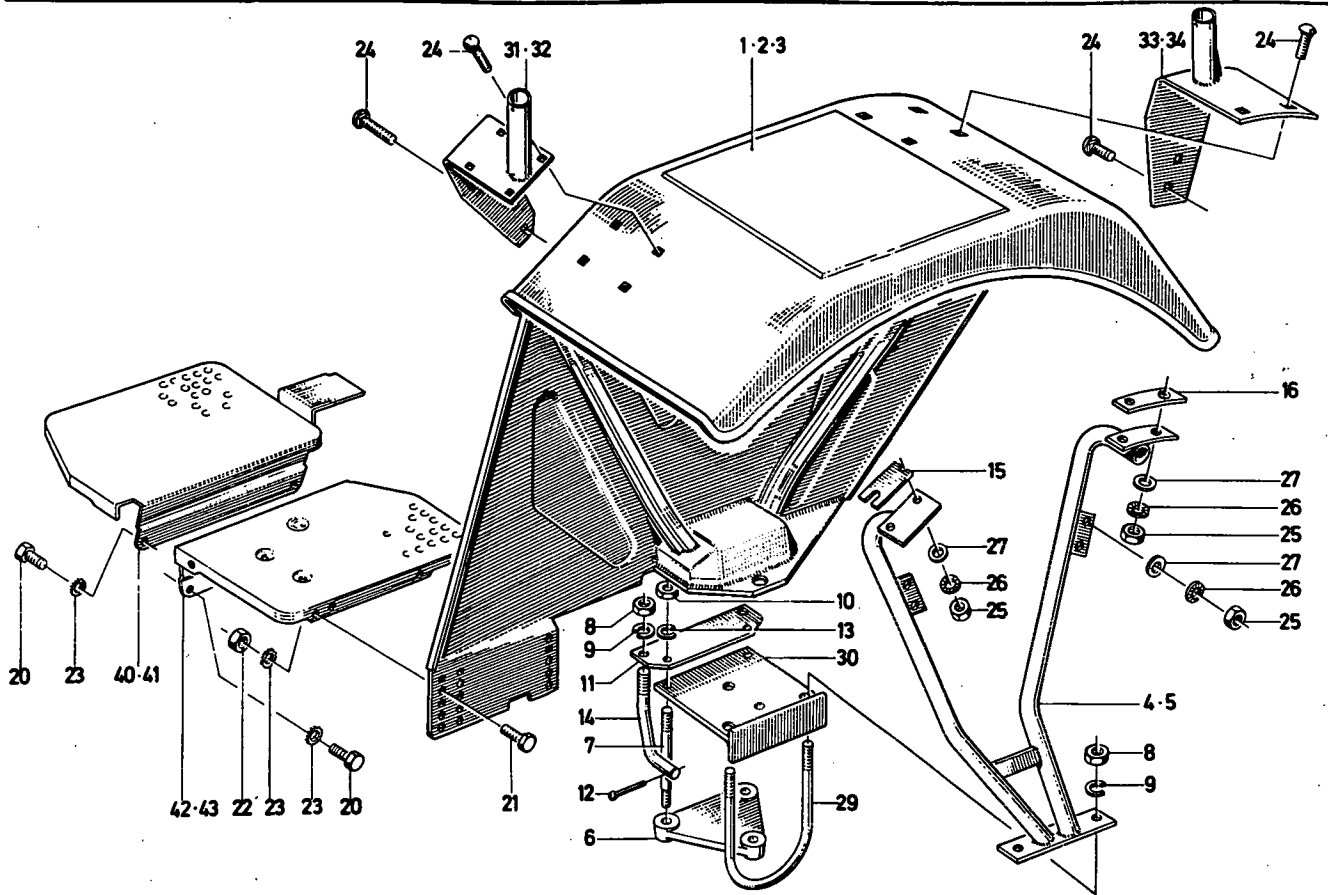

1004-51 502 0170

| Bld. Nr. | Teile-Nr. | Stück-Zahl | Deutsch            | English           | Français           | Español             | Nummer/Bemerkung                      | ETK |
|----------|-----------|------------|--------------------|-------------------|--------------------|---------------------|---------------------------------------|-----|
| 1        | 238 6382  | 1          | KOTFLUEGEL         | MUDGUARD          | GARDE-BOUE         | GUARDABARRROS       | 8195-LINKS                            |     |
| 2        | 238 6384  | 1          | KOTFLUEGEL         | MUDGUARD          | GARDE-BOUE         | GUARDABARRROS       | 8195-LINKS<br>8009-ALLRAD AUSFUEHRUNG |     |
| 3        | 238 6383  | 1          | KOTFLUEGEL         | MUDGUARD          | GARDE-BOUE         | GUARDABARRROS       | 8267-RECHTS                           |     |
| 4        | 237 3632  | 1          | KOTFLUEGELSTUETZE  | MUDGUARD SUPPORT  | SUPP DE GARDE-BOUE | APOYO GUARDABARRROS | 8195-LINKS                            |     |
| 5        | 237 3633  | 1          | KOTFLUEGELSTUETZE  | MUDGUARD SUPPORT  | SUPP DE GARDE-BOUE | APOYO GUARDABARRROS | 8267-RECHTS                           |     |
| 6        | 230 4120  | 2          | ABSTANDESTUECK     | SPACER            | ENTRETOISE         | PIEZA DISTANCIARIA  |                                       |     |
| 7        | 110 1932  | 6          | STIFTSCHRAUBE      | STUD              | GOUJON             | ESPARRAGO           | M12X70 DIN 934 B-B A4C                |     |
| 8        | 111 2874  | 8          | SECHSKANTMUTTER    | HEX-NUT           | ECROU 6 PANS       | TUERCA HEXAGONAL    | M 14 DIN 934-M2 A4C                   |     |
| 9        | 110 7240  | 8          | FEDERRING          | SPRING LOCKWASHER | RONDELLE GROMER    | ARANDELA ELASTICA   | 814 DIN 127 V2KC                      |     |
| 10       | 111 2858  | 6          | SECHSKANTMUTTER    | HEX-NUT           | ECROU 6 PANS       | TUERCA HEXAGONAL    | M12 DIN 934 M8 A4C                    |     |
| 11       | 238 7267  | 2          | LASCHE             | CONNECTING PLATE  | ECLISSE            | ECLISA              |                                       |     |
| 12       | 110 6449  | 4          | SPLINT             | SPLIT PIN         | GOUILLE FENDUE     | PASADOR ALETAS      | 4 X 22DIN 94 V2KC                     |     |
| 13       | 110 7289  | 5          | FEDERSCHWEIBE      | SPRING WASHER     | RONDELLE ELASTIQUE | ARANDELA ELASTICA   | 832 DIN 137 A4C                       |     |
| 14       | 238 7266  | 4          | HAKENSCHRAUBE      | HOOK SCREW        | VIS A CROCHET      | TORNILLE-CANCAPO    |                                       |     |
| 15       | 230 4980  | 4          | BEILAGE            | SHIM              | CALE               | SUPLEMENTO          |                                       |     |
| 16       | 230 4981  | 4          | BEILAGE            | SHIM              | CALE               | SUPLEMENTO          |                                       |     |
| 20       | 111 2299  | 4          | SECHSKANTSCHRAUBE  | HEX-BOLT          | VIS 6 PANS         | TORNILLE HEXAGONAL  | M8X12 DIN 933-2-B-A4C                 |     |
| 21       | 111 2305  | 4          | SECHSKANTSCHRAUBE  | HEX-BOLT          | VIS 6 PANS         | TORNILLE HEXAGONAL  | M8X150 DIN 933-M8-B-A4C               |     |
| 22       | 111 2824  | 4          | SECHSKANTMUTTER    | HEX-NUT           | ECROU 6 PANS       | TUERCA HEXAGONAL    | M 8 DIN 934-M 2 A4C                   |     |
| 23       | 110 1492  | 8          | ZAMNSCHWEIBE       | TOOTHED WASHER    | RONDELLE DENTEE    | ARANDELA DENTADA    | A 8-22DIN 6797 V2KC                   |     |
| 24       | 110 3420  | 20         | FLACHRUNDSCHRAUBE  | TRUSS-HEAD SCREW  | VIS TETE BOMBEE    | TORN-CAE-SEMIRED.   | M10X30 DIN 603-A4C                    |     |
| 25       | 111 2892  | 20         | SECHSKANTMUTTER    | HEX-NUT           | ECROU 6 PANS       | TUERCA HEXAGONAL    | M10 DIN 934-M55 V2KC                  |     |
| 26       | 116 9674  | 20         | SKT-SCHWEISSMUTTER | WELDING NUT       | ECROU 6 PANS SOUDE | TUERCA HEX-SOLDAD.  | 104 2203                              |     |

| Bld<br>Nr. | Teil-Nr. | Stück-<br>Zahl | Deutsch        | English         | Français        | Español      | Nummer/Bemerkung                    | ETK |
|------------|----------|----------------|----------------|-----------------|-----------------|--------------|-------------------------------------|-----|
| 27         | 110 3990 | 20             | SCHEIBE        | DISC/PANE/PLATE | RONDELLE/DISQUE | DISCO        | 11.5 DIN 440 A9C                    |     |
| 29         | 230 4958 | 2              | BUEGELSCHRAUBE | U-BOLT          | VIS/BOULON EN U | TORNILLO ASA |                                     |     |
| 30         | 230 4920 | 2              | SCHEIBE        | DISC/PANE/PLATE | RONDELLE/DISQUE | DISCO        |                                     |     |
| 31         | 238 6360 | 1              | KONSOLE        | BRACKET/CONSOLE | CONSOLE         | CONSOLA      | B348.VORN-LINKS                     |     |
| 32         | 238 6361 | 1              | KONSOLE        | BRACKET/CONSOLE | CONSOLE         | CONSOLA      | B349.VORN-RECHTS                    |     |
| 33         | 238 6353 | 1              | KONSOLE        | BRACKET/CONSOLE | CONSOLE         | CONSOLA      | B151.HINTEN-LINKS                   |     |
| 34         | 238 6354 | 1              | KONSOLE        | BRACKET/CONSOLE | CONSOLE         | CONSOLA      | B152.HINTEN-RECHTS                  |     |
| 40         | 230 4987 | 1              | BODENBLECH     | BOTTOM PLATE    | TOLE DE FOND    | CHAPA PISO   | B267.RECHTS                         |     |
| 41         | 232 2986 | 1              | BODENBLECH     | BOTTOM PLATE    | TOLE DE FOND    | CHAPA PISO   | B267.RECHTS<br>B357.WASSERDICHT     |     |
| 42         | 233 0304 | 1              | BODENBLECH     | BOTTOM PLATE    | TOLE DE FOND    | CHAPA PISO   | B195.LINKS                          |     |
| 43         | 233 0305 | 1              | BODENBLECH     | BOTTOM PLATE    | TOLE DE FOND    | CHAPA PISO   | B195.LINKS<br>B009.ALLRADAUSFUHRUNG |     |

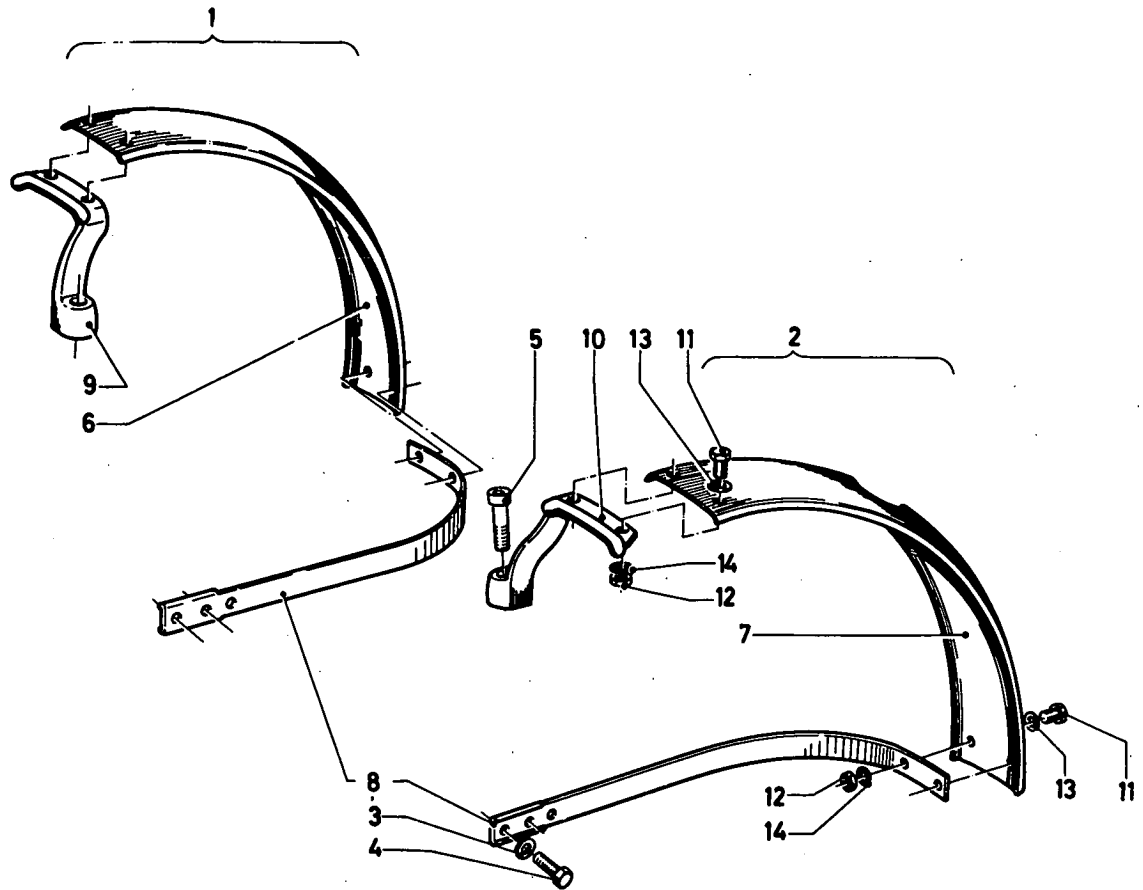

1145-52 500 6084

| Bsp<br>Nr. | Teil-Nr. | Stück-<br>Zahl | Deutsch           | English           | Français          | Español            | Nummer/Bemerkung              | ETK |
|------------|----------|----------------|-------------------|-------------------|-------------------|--------------------|-------------------------------|-----|
| 1          | 338 9484 | 1              | KOTFLUEGEL-VORN   | FRONT MUDGUARD    | GARDE-BOUE AV     | GUARDABARROS DELAN | 1145-52-03-10<br>8267, RECHTS |     |
| 2          | 338 9485 | 1              | KOTFLUEGEL-VORN   | FRONT MUDGUARD    | GARDE-BOUE AV     | GUARDABARROS DELAN | 1145-52-03-20<br>8195, LINKS  |     |
| 3          | 116 9694 | 4              | SICHERUNGSSCHEIBE | LOCKING WASHER    | RONDELLE SECURITE | ARANDELA SEGURIDAD | 10 H 2203                     |     |
| 4          | 111 2412 | 4              | SECHSKANTSCHRAUBE | HEX-BOLT          | VIS 6 PANS        | TORNILLO HEXAGONAL | M10X 22 DIN 933- 8.8-A4C      |     |
| 5          | 111 0763 | 2              | ZYLINDERSCHRAUBE  | CHEESE-HEAD SCREW | VIS TETE CYLINDR. | TORN-CBZA-CILIND.  | M12X 40DIN 932-10.9           |     |
| 6          | 231 5249 | 1              | SCHUTZBLECH       | GUARD PLATE       | TOLE DE GARDE     | CAPA PROTECTORA    | 1145-52-03-03<br>8267, RECHTS |     |
| 7          | 231 5250 | 1              | SCHUTZBLECH       | GUARD PLATE       | TOLE DE GARDE     | CAPA PROTECTORA    | 1145-52-03-02<br>8195, LINKS  |     |
| 8          | 231 5251 | 1              | HALTER            | RETAINER          | SUPPORT/PORTEUTIL | SOPORTE            | 1145-52-02-09                 |     |
| 9          | 231 5252 | 1              | HALTER            | RETAINER          | SUPPORT/PORTEUTIL | SOPORTE            | 1145-52-03-04<br>8267, RECHTS |     |
| 10         | 231 5254 | 1              | HALTER            | RETAINER          | SUPPORT/PORTEUTIL | SOPORTE            | 1145-52-03-05<br>8195, LINKS  |     |
| 11         | 111 2322 | 4              | SECHSKANTSCHRAUBE | HEX-BOLT          | VIS 6 PANS        | TORNILLO HEXAGONAL | M 8X 20 DIN 933- 8.8-A4C      |     |
| 12         | 112 2477 | 4              | SECHSKANTMUTTER   | HEX-NUT           | ECROU 6 PANS      | TUERCA HEXAGONAL   | M 8 DIN 934-M10 VZKC          |     |
| 13         | 110 7101 | 4              | SCHEIBE           | DISC/PANE/PLATE   | RONDELLE/DISQUE   | DISCO              | A 8.40IN 125-ST-A4C           |     |
| 14         | 116 9689 | 4              | SICHERUNGSSCHEIBE | LOCKING WASHER    | RONDELLE SECURITE | ARANDELA SEGURIDAD | 8 H 2203                      |     |

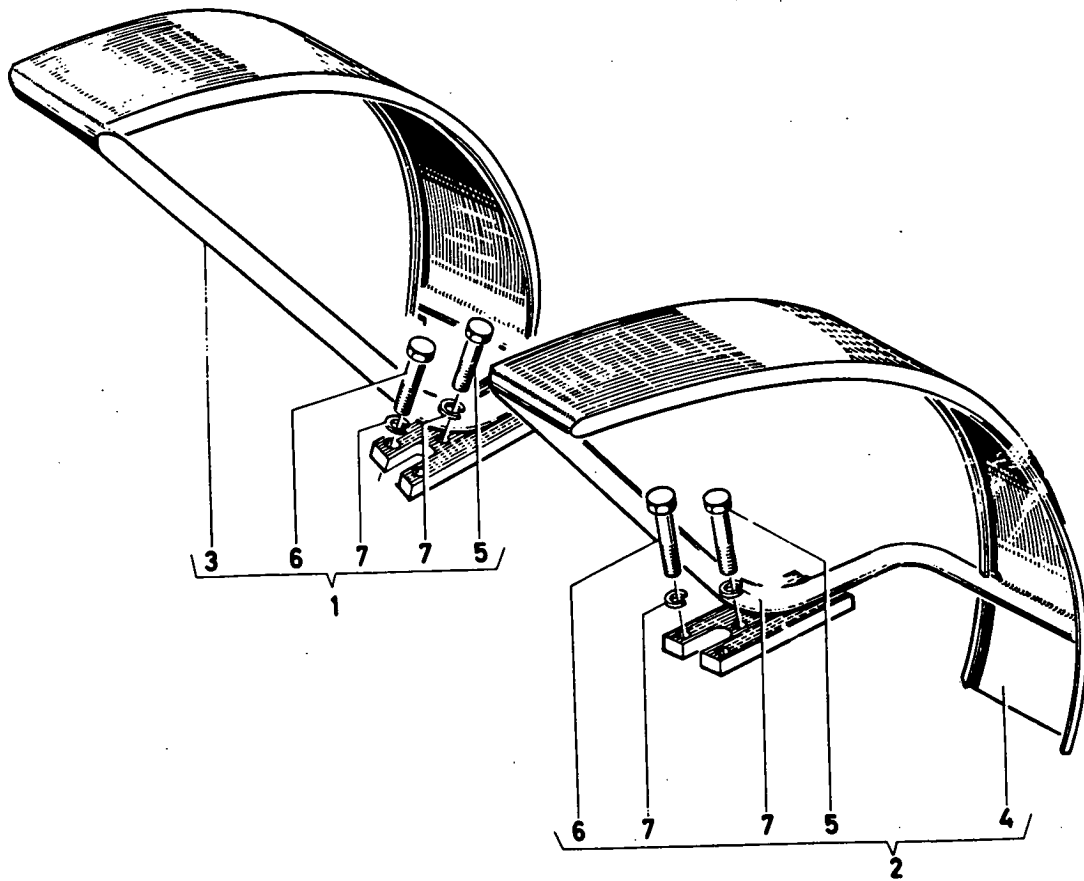

1002-52 500 6085

| Bld.-Nr. | Teil-Nr. | Stück-Zahl | Deutsch           | English           | Français        | Español            | Nummer/Bemerkung         | ETK |
|----------|----------|------------|-------------------|-------------------|-----------------|--------------------|--------------------------|-----|
| 1        | 237 2956 | 1          | KOTFLUEGEL-VORN   | FRONT MUDGUARD    | GARDE-BOUE AV   | GUARDABARROS DELAN | 8267-RECHTS              |     |
| 2        | 237 2957 | 1          | KOTFLUEGEL-VORN   | FRONT MUDGUARD    | GARDE-BOUE AV   | GUARDABARROS DELAN | 8195-LINKS               |     |
| 3        | 237 2959 | 1          | KOTFLUEGEL        | MUDGUARD          | GARDE-BOUE      | GUARDABARROS       | 8267-RECHT               |     |
| 4        | 237 2960 | 1          | KOTFLUEGEL        | MUDGUARD          | GARDE-BOUE      | GUARDABARROS       | 8195-LINKS               |     |
| 5        | 111 1339 | 1          | SECHSKANTSCHRAUBE | HEX-BOLT          | VIS 6 PANS      | TORNILLO HEXAGONAL | M10X 50 DIN 931- 8.8-A4C |     |
| 6        | 112 3727 | 2          | SECHSKANTSCHRAUBE | HEX-BOLT          | VIS 6 PANS      | TORNILLO HEXAGONAL | M10X 70 DIN 931- 8.8-A4C |     |
| 7        | 111 9613 | 3          | FEDERRING         | SPRING LOCKWASHER | RONDELLE GROMER | ARANDELA ELASTICA  | 10DIN 7980 VZKC          |     |



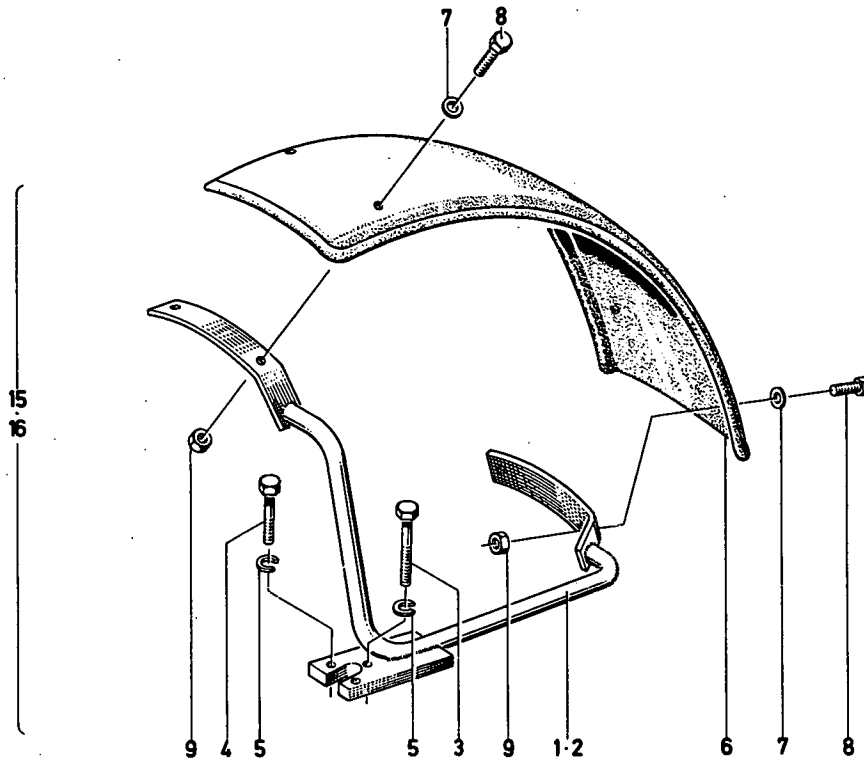

1005-52 501 7012

| Bild-Nr. | Teil-Nr. | Stück-Zahl | Deutsch           | English           | Français           | Español            | Nummer/Bemerkung          | ETK |
|----------|----------|------------|-------------------|-------------------|--------------------|--------------------|---------------------------|-----|
| 1        | 237 8541 | 1          | KOTFLUEGELSTUETZE | MUDGUARD SUPPORT  | SUPP DE GARDE-BOUE | APOYO GUARDABARROS | B267-RECHTS               |     |
| 2        | 237 8542 | 1          | KOTFLUEGELSTUETZE | MUDGUARD SUPPORT  | SUPP DE GARDE-BOUE | APOYO GUARDABARROS | B175-LINKS                |     |
| 3        | 111 1339 | 1          | SECHSKANTSCHRAUBE | HEX-BOLT          | VIS 6 PANS         | TORNILLO HEXAGONAL | M10X80 DIN 931-8-8-A4C    |     |
| 4        | 112 3727 | 2          | SECHSKANTSCHRAUBE | HEX-BOLT          | VIS 6 PANS         | TORNILLO HEXAGONAL | M10X70 DIN 931-8-8-A4C    |     |
| 5        | 111 9613 | 3          | FEDERRING         | SPRING LOCKWASHER | RONDELLE GROUER    | ARANDELA ELASTICA  | 100DIN 7980 VZKC          |     |
| 6        | 237 8553 | 1          | GUMMIKOTFLUEGEL   | MUDGUARD          | GARDE-BOUE CAOUTCH | GUARDABARROS CAUCH |                           |     |
| 7        | 110 7105 | 4          | SCHWEIBE          | DISC/PANE/PLATE   | RONDELLE/DISQUE    | DISCO              | A10-5 DIN 125-ST-A4C      |     |
| 8        | 111 2333 | 4          | SECHSKANTSCHRAUBE | HEX-BOLT          | VIS 6 PANS         | TORNILLO HEXAGONAL | M 8X 25 DIN 933-M 8-8 A4C |     |
| 9        | 112 2477 | 4          | SECHSKANMUTTER    | HEX-NUT           | ECROU 6 PANS       | TUERCA HEXAGONAL   | M8 DIN 934-M10-A4C        |     |

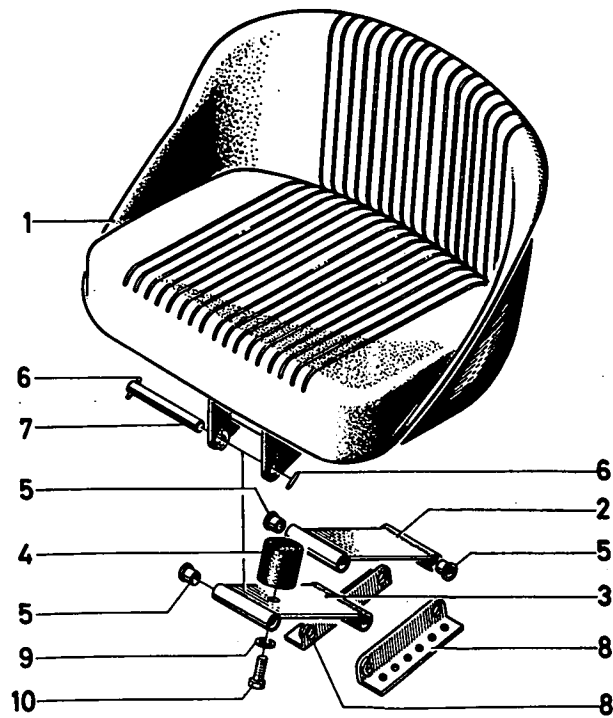

1001-54 502 0230

| Bild Nr. | Teile-Nr. | Stück-Zahl | Deutsch           | English         | Français        | Español             | Nummer/Bemerkung      | ETK |
|----------|-----------|------------|-------------------|-----------------|-----------------|---------------------|-----------------------|-----|
| 1        | 232 7947  | 1          | SITZMULDE         | SEAT PAN        | BAQUET DE SIEGE | PLATO ASIEN TO      |                       |     |
| 2        | 232 7948  | 1          | SITZSCHWINGE      | SEAT WING       | BRAS SUPP SIEGE | BRAZO PORTAASIEN TO |                       |     |
| 3        | 232 7949  | 1          | SITZSCHWINGE      | SEAT WING       | BRAS SUPP SIEGE | BRAZO PORTAASIEN TO |                       |     |
| 4        | 232 7950  | 1          | PUFFER            | BUFFER/MOUNT    | TAMPON          | TOPE                |                       |     |
| 5        | 232 7951  | 8          | FUEHRUNGSBUCHSE   | GUIDE BUSH      | DOUILLE-PILOTE  | CASQUILLO GUIA      |                       |     |
| 6        | 232 7952  | 8          | SPANNHUELSE       | DOWEL SLEEVE    | DOUILLE SERRAGE | CASQUILLO FIADOR    |                       |     |
| 7        | 238 5878  | 4          | BOLZEN            | PIN/BOLT/STUD   | BOULON/AXE      | BULON               |                       |     |
| 8        | 232 4663  | 2          | WINKEL            | ANGLE PLATE     | EQUERRE         | ANGULO              |                       |     |
| 9        | 110 7105  | 1          | SCHEIBE           | DISC/PANE/PLATE | RONDELLE/DISQUE | DISCO               | 10x5 DIN 125-ST-A4C C |     |
| 10       | 110 8330  | 1          | SECHSKANTSCHRAUBE | HEX-BOLT        | VIS 6 PANS      | TORNILLO HEXAGONAL  | 110x15 DIN 601        |     |

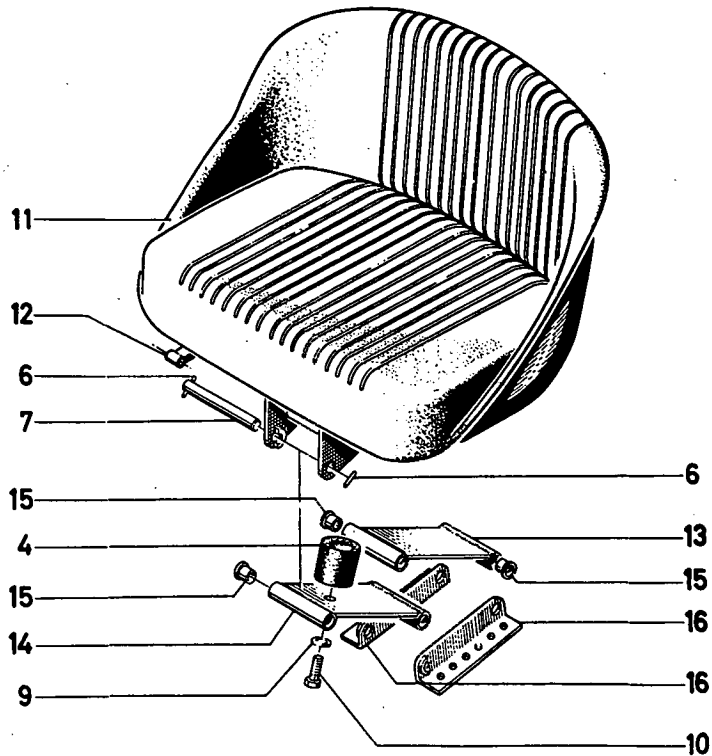

1001-54 502 0231

| Bild Nr. | Teil-Nr. | Stück-Zahl | Deutsch           | English         | Français          | Español            | Nummer/Bemerkung    | ETK |
|----------|----------|------------|-------------------|-----------------|-------------------|--------------------|---------------------|-----|
| 4        | 232 7950 | 1          | PUFFER            | BUFFER/MOUNT    | TAMPON            | TOPE               |                     |     |
| 6        | 232 7952 | 4          | SPANNHUELSE       | DOWEL SLEEVE    | DOUILLE SERRAGE   | CASQUILLO FIADOR   |                     |     |
| 7        | 238 5878 | 4          | BÖLZEN            | PIN/BOLT/STUD   | BOULON/AXE        | BULON              |                     |     |
| 9        | 110 7105 | 1          | SCHEIBE           | DISC/PANE/PLATE | RONDELLE/DISQUE   | DISCO              | A10-50IN 125-ST-4NC |     |
| 10       | 110 8330 | 1          | SECHSKANTSCHRAUBE | HEX-BOLT        | VIS 6 PANS        | TORNILLO HEXAGONAL | M10X 15 MU DIN 601  |     |
| 11       | 238 5879 | 1          | SITZMULDE         | SEAT PAN        | BAQUET DE SIEGE   | PLATO ASIENTO      |                     |     |
| 12       | 238 6710 | 7          | KLAMMER           | CLAMP/CLIP      | PINCE/AGRAFE/ATTA | PINZA              |                     |     |
| 13       | 238 6711 | 1          | SCHWINGE          | SHACKLE         | BALANCIER         | BALANCIÓN/PLUMA    |                     |     |
| 14       | 238 6712 | 1          | SCHWINGE          | SHACKLE         | BALANCIER         | BALANCIÓN/PLUMA    |                     |     |
| 15       | 231 0918 | 8          | BÜCHSE            | BUSH            | DOUILLE           | CASQUILLO          |                     |     |
| 16       | 238 6714 | 2          | WINKEL            | ANGLE PLATE     | EQUERRE           | ANGULO             |                     |     |

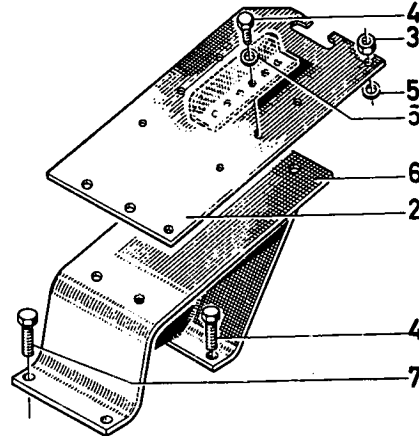
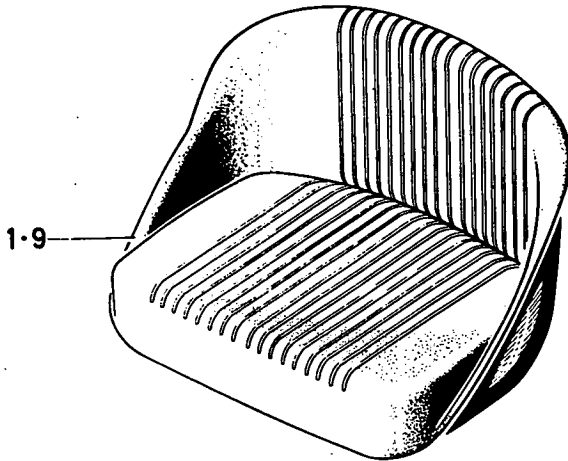

1001-54 500 4234

| Bild Nr. | Teil-Nr. | Stück-Zahl | Deutsch           | English         | Français            | Español            | Nummer/Bemerkung   | ETK |
|----------|----------|------------|-------------------|-----------------|---------------------|--------------------|--|-----|
| 1        | 232 5565 | 1P         | FAHRERSITZ        | DRIVER'S SEAT   | SIEGE DE CONDUCTEUR | ASIENTO CONDUCTOR  | 8285, SIEHE POS. 9<br>8076, EINZELTEILE SIEHE<br>1001-54 502 0230      |     |
| 2        | 231 5434 | 1          | FUEHRUNGSBLECH    | GUIDE PLATE     | TOLE DE GUIDAGE     | CHAPA GUIA         |  |     |
| 3        | 111 2624 | 4          | SECHSKANTMUTTER   | HEX-NUT         | ECROU 6 PANS        | TUERCA HEXAGONAL   | M 8 DIN 934-M 8 A4C  |     |
| 4        | 111 2305 | 4          | SECHSKANTSCHRAUBE | HEX-BOLT        | VIS 6 PANS          | TORNILLO HEXAGONAL | M 8 X 15 -DIN 933- 8-8-A4C   |     |
| 5        | 110 7101 | 4          | SCHEIBE           | DISC/PANE/PLATE | RONDELLE/DISQUE     | DISCO              | A 8-8DIN 125-ST-A4C  |     |
| 6        | 230 2205 | 1          | KONSOLE           | BRACKET/CONSOLE | CONSOLE             | CONSOLA            |  |     |
| 7        | 111 2311 | 2          | SECHSKANTSCHRAUBE | HEX-BOLT        | VIS 6 PANS          | TORNILLO HEXAGONAL | M 8 X 18 DIN 933- 8-8-A4C  |     |
| 9        | 238 2801 | 1          | FAHRERSITZ        | DRIVER'S SEAT   | SIEGE DE CONDUCTEUR | ASIENTO CONDUCTOR  | 8337, VOLLSTAENDIG<br>8076, EINZELTEILE SIEHE POS.<br>1001-54 502 0231 |     |

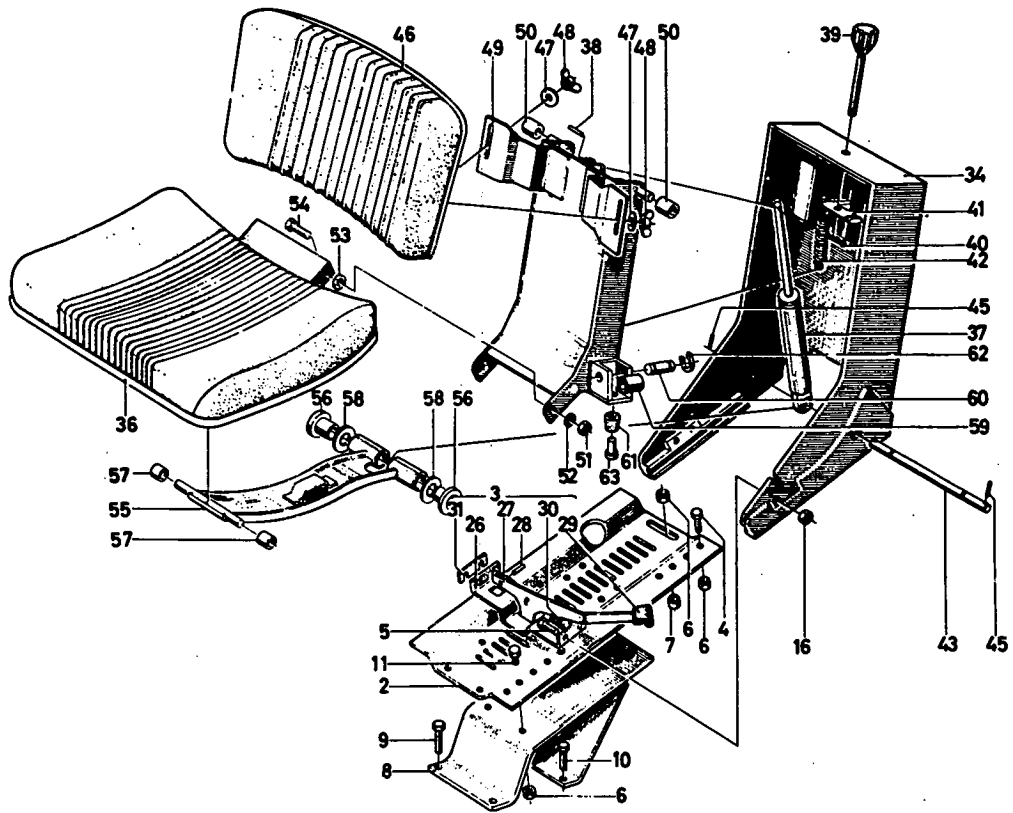

1001-54 500 4235

| Bild Nr. | Teile-Nr. | Stück-Zahl | Deutsch           | English         | Français          | Español            | Nummer/Bemerkung          | ETX |
|----------|-----------|------------|-------------------|-----------------|-------------------|--------------------|---------------------------|-----|
| 2        | 232 1958  | 1          | FUEHRUNGSBLECH    | GUIDE PLATE     | TOLE DE GUIDAGE   | CHAPA GUIA         |                           |     |
| 3        | 232 1004  | 1          | RASTVERSTELLUNG   | ADJUST-DEVICE   | SECTEUR A CRANS   | SECTOR GRADUACION  | KPL.-7. POS. 26-33        |     |
| 4        | 111 2299  | 2          | SECHSKANTSCHRAUBE | HEX-BOLT        | VIS 6 PANS        | TORNILLO HEXAGONAL | M 8 X 12 DIN 933- 8-8-A4C |     |
| 5        | 112 3749  | 4          | SECHSKANTSCHRAUBE | HEX-BOLT        | VIS 6 PANS        | TORNILLO HEXAGONAL | M 6 X 25 DIN 933- 8-8-A4C |     |
| 6        | 111 2624  | 6          | SECHSKANTMUTTER   | HEX-NUT         | ECROU 6 PANS      | TUERCA HEXAGONAL   | M 8 DIN 934-M 8 A4C       |     |
| 7        | 231 5935  | 4          | ABSTANDBUCHSE     | SPACER BUSH     | DOUILLE ECARTEN   | CASQ-DISTANCIARIO  |                           |     |
| 8        | 230 2205  | 1          | KONSOLE           | BRACKET/CONSOLE | CONSOLE           | CONSOLA            |                           |     |
| 9        | 111 2311  | 2          | SECHSKANTSCHRAUBE | HEX-BOLT        | VIS 6 PANS        | TORNILLO HEXAGONAL | M 8 X 18 DIN 933- 8-8-A4C |     |
| 10       | 111 2305  | 2          | SECHSKANTSCHRAUBE | HEX-BOLT        | VIS 6 PANS        | TORNILLO HEXAGONAL | M 8 X 15 DIN 933- 8-8-A4C |     |
| 11       | 111 2326  | 4          | SECHSKANTSCHRAUBE | HEX-BOLT        | VIS 6 PANS        | TORNILLO HEXAGONAL | M 8 X 22 DIN 933- 8-8-A4C |     |
| 16       | 111 2613  | 4          | SECHSKANTMUTTER   | HEX-NUT         | ECROU 6 PANS      | TUERCA HEXAGONAL   | M 6 DIN 934-M 8 A4C       |     |
| 26       | 232 0882  | 1          | FUEHRUNGSPLATTE   | GUIDE PLATE     | PLAQUE DE GUIDAGE | PLACA GUIA         |                           |     |
| 27       | 232 0881  | 1          | HEBEL             | LEVER/ARM       | LEVIER            | PALANCA            |                           |     |
| 28       | 111 5433  | 1          | SPANNHUELSE       | DOWEL SLEEVE    | DOUILLE SERRAGE   | CASQUILLO FIADOR   | 5 X 14 DIN 1481           |     |
| 29       | 232 1011  | 1          | GRIFF             | HANDLE          | POIGNEE/MANETTE   | PUNO/ASA           |                           |     |
| 30       | 232 1012  | 1          | ZUGFEDER          | DRAW SPRING     | RESSORT TRACTION  | RESORTE TRACCION   |                           |     |
| 31       | 232 5588  | 1          | BEILAGE           | SHIM            | CALE              | SUPLEMENTO         |                           |     |
| 34       | 233 3440  | 1          | GEHAUSE           | HOUSING/CASE    | CARTER/BOITIER    | CAJA/BLOQUE/CUERPO |                           |     |
| 36       | 233 3446  | 1          | SITZPOLSTER       | SEAT PAD        | REMBOURRAGE       | TAPIZADO ASIENTO   |                           |     |
| 37       | 233 3447  | 1          | STOSSDAEMPFER     | SHOCK ABSORBER  | AMORTISSEUR       | AMORTIGUADOR       |                           |     |
| 38       | 110 4188  | 1          | ROHRNIET          | TUBULAR RIVET   | RIVET TUBULAIRE   | RENACHE HUECO      | 89X10-75X25 DIN 7340-ST   |     |
| 39       | 232 1387  | 1          | SPINDEL           | SPINDLE         | BROCHE            | MUSILLO            |                           |     |
| 40       | 110 6431  | 1          | SPLINT            | SPLIT PIN       | GOUVILLE FENDUE   | PASADOR ALETAS     | 3 X 20 DIN 94             |     |
| 43       | 231 4547  | 1          | FEDERBOCK         | SPRING BRACKET  | MAIN DE RESSORT   | CABALL-PORTABALLES |                           |     |
| 42       | 233 3448  | 2          | ZUGFEDER          | DRAW SPRING     | RESSORT TRACTION  | RESORTE TRACCION   |                           |     |

| Bld<br>Nr. | Teil-Nr. | Stück-<br>Zahl | Deutsch           | English         | Français          | Español            | Nummer/Bemerkung            | ETK |
|------------|----------|----------------|-------------------|-----------------|-------------------|--------------------|-----------------------------|-----|
| 43         | 233 8048 | 1              | BOLZEN            | PIN/BOLT/STUD   | BOULON/AXE        | BULON              |                             |     |
| 45         | 111 5423 | 2              | SPANNHUELSE       | DOWEL SLEEVE    | DOUILLE SERRAGE   | CASQUILLO FIADOR   | 4 X 24 DIN 1481             |     |
| 46         | 233 3433 | 1              | RUECKENPOLSTER    | BACK PAD        | REMBOURRAGE DOSS  | COJIN RESPALDO     |                             |     |
| 47         | 112 7709 | 2              | SCHEIBE           | DISC/PANE/PLATE | RONDELLE/DISQUE   | DISCO              | A 8.8 DIN 9021              |     |
| 48         | 110 7359 | 2              | FLUEGELMUTTER     | WING NUT        | ECROU A AILETTES  | TUERCA MARIPOSA    | M 8 DIV 315-G GTW35 VZKC    |     |
| 49         | 233 8052 | 1              | PLATTE            | PLATE           | PLAQUE            | PLACA              |                             |     |
| 50         | 233 8053 | 2              | ROLLE             | ROLLER          | ROULEAU/GALET     | RODILLO/POLEA      |                             |     |
| 51         | 110 2756 | 2              | SECHSKANTMUTTER   | HEX-NUT         | ECROU 6 PANS      | TUERCA HEXAGONAL   | M10 DIN 985- 8 VZKC         |     |
| 52         | 110 7105 | 2              | SCHEIBE           | DISC/PANE/PLATE | RONDELLE/DISQUE   | DISCO              | A10.5 DIV 125-ST-A4C        |     |
| 53         | 233 3437 | 2              | SCHEIBE           | DISC/PANE/PLATE | RONDELLE/DISQUE   | DISCO              |                             |     |
| 54         | 111 2429 | 2              | SECHSKANTSCHRAUBE | HEX-BOLT        | VIS 6 PANS        | TORNILLO HEXAGONAL | M10X 30 DIN 933- 8.8-A4C    |     |
| 55         | 233 8049 | 1              | SITZSCHWINGE      | SEAT WING       | BRAS SUPP SIEGE   | BRAZO PORTAASIENTO |                             |     |
| 56         | 231 0918 | 2              | BUECHSE           | BUSH            | BOITE             | CASQUILLO          |                             |     |
| 57         | 233 3444 | 2              | ROLLE             | ROLLER          | ROULEAU/GALET     | RODILLO/POLEA      |                             |     |
| 58         | 233 3437 | 2              | SCHEIBE           | DISC/PANE/PLATE | RONDELLE/DISQUE   | DISCO              |                             |     |
| 59         | 233 8054 | 2              | ROLLE             | ROLLER          | ROULEAU/GALET     | RODILLO/POLEA      |                             |     |
| 60         | 233 8055 | 2              | BOLZEN            | PIN/BOLT/STUD   | BOULON/AXE        | BULON              |                             |     |
| 61         | 233 8056 | 2              | PUFFER            | BUFFER/MOUNT    | TAMPON            | TOPE               |                             |     |
| 62         | 112 6001 | 4              | SICHERUNGSSCHEIBE | LOCKING WASHER  | RONDELLE SECURITE | ARANDELA SEGURIDAD | 5 DIN 6799-BZ               |     |
| 63         | 111 4815 | 2              | HOHLNIET          | HOLLOW RIVET    | RIVET CREUX       | REMACHE HUECO      | 20F 3X 55X 48 DIN 1434- 5-8 |     |



**FAHRERSITZ (VERSTELLBAR)  
DRIVER'S SEAT ADJUSTABLE  
SIEGE DE CONDUCTEUR RÉGLABLE  
ASIENTO DE CONDUCTOR (GRADUABLE)**

1001-54 501 7169

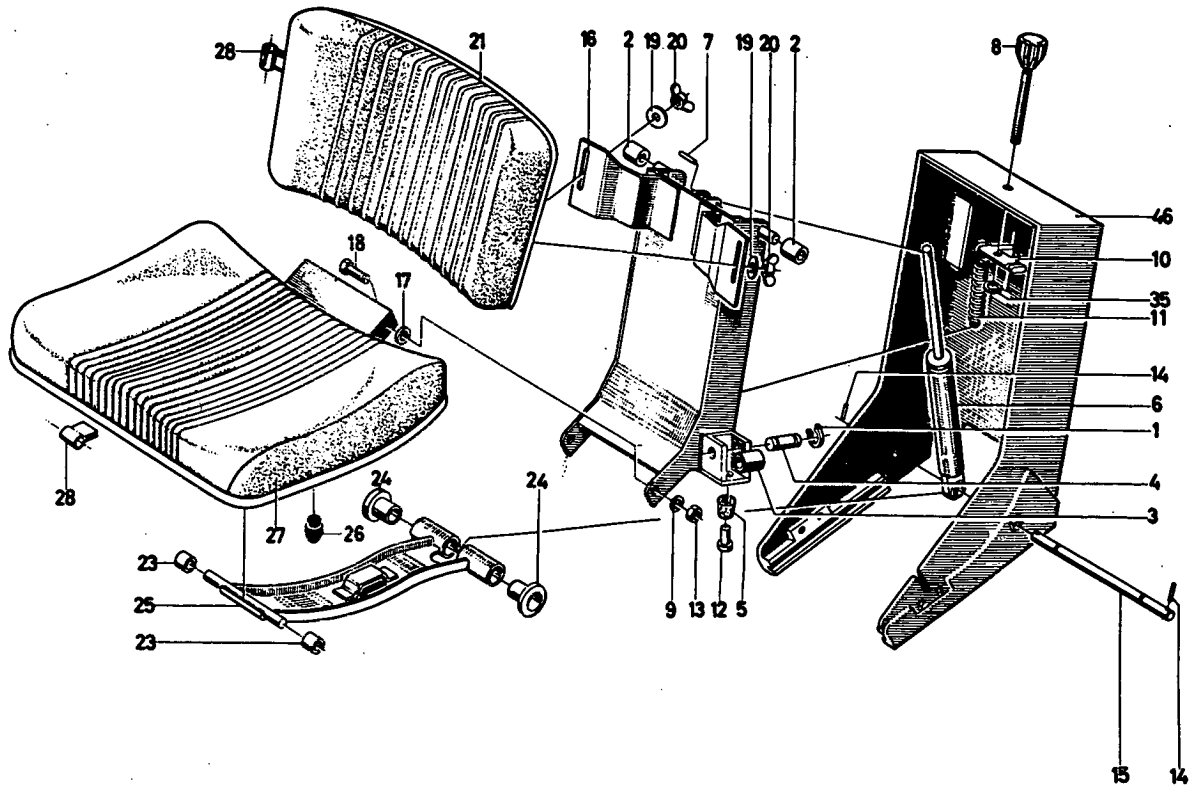

1001-54 501 7169

| Bild Nr. | Teile-Nr. | Stück-Zahl | Deutsch           | English         | Français          | Español            | Nummer/Bemerkung         | ETK | ETK |
|----------|-----------|------------|-------------------|-----------------|-------------------|--------------------|--------------------------|-----|-----|
| 1        | 112 6001  | 4          | SICHERUNGSSCHEIBE | LOCKING WASHER  | RONDELLE SECURITE | ARANDELA SEGURIDAD | 5 DIN 6799-BZ            |     |     |
| 2        | 233 8053  | 2          | ROLLE             | ROLLER          | ROULEAU/GALET     | RODILLO/POLEA      |                          |     |     |
| 3        | 233 8054  | 4          | ROLLE             | ROLLER          | ROULEAU/GALET     | RODILLO/POLEA      |                          |     |     |
| 4        | 233 8055  | 2          | BOLZEN            | PIN/BOLT/STUD   | BOULON/AXE        | BULON              |                          |     |     |
| 5        | 231 2286  | 2          | PUFFER            | BUFFER/MOUNT    | TAMPON            | TOPE               |                          |     |     |
| 6        | 233 3447  | 1          | STOSSDAEMPFER     | SHOCK ABSORBER  | AMORTISSEUR       | AMORTIGUADOR       |                          |     |     |
| 7        | 110 4185  | 1          | ROHRNIET          | TUBULAR RIVET   | RIVET TUBULAIRE   | REMACHE HUECO      | 84X0,75X25DIN 734C-ST    |     |     |
| 8        | 232 1187  | 1          | VERSTELLSPINDEL   | SPINDLE         | BROCHE REGLAGE    | HUSILLO GRADUACION |                          |     |     |
| 9        | 110 7105  | 2          | SCHEIBE           | DISC/PANE/PLATE | RONDELLE/DISQUE   | DISCO              | 110,5DIN 125-ST-A4C      |     |     |
| 10       | 231 4547  | 1          | FEDERBECK         | SPRING BRACKET  | MAIN DE RESSORT   | CABALL-FORTABALLES |                          |     |     |
| 11       | 233 3448  | 2          | ZUGFEDER          | DRAW SPRING     | RESSORT TRACTION  | RESORTE TRACCION   |                          |     | 61  |
| 12       | 111 8415  | 2          | HÖHLENIET         | HOLLOW RIVET    | PIVET CREUX       | REMACHE HUECO      | 44X13X12DIN 7321 VERZK   |     |     |
| 13       | 110 2756  | 2          | SECHSKANTMUTTER   | HEX-NUT         | ECROU 6 PANS      | TUERCA HEXAGONAL   | M10 DIN 934-6 V2KC       |     |     |
| 14       | 111 5423  | 2          | SPANNHULSE        | DOWEL SLEEVE    | DOUILLE SERRAGE   | CASQUILLO FIADOR   | 4 X 24DIN 1441           |     |     |
| 15       | 233 8048  | 1          | BOLZEN            | PIN/BOLT/STUD   | BOULON/AXE        | BULON              |                          |     |     |
| 16       | 238 6975  | 1          | RUECKLEHRAHMEN    | BACKREST FRAME  | CADRE DE DOSSIER  | MARCO RESP-ASIENTO |                          |     |     |
| 17       | 110 7110  | 2          | SCHEIBE           | DISC/PANE/PLATE | RONDELLE/DISQUE   | DISCO              | 113 DIN 125-ST-A4C       |     |     |
| 18       | 111 2429  | 2          | SECHSKANTSCHRAUBE | HEX-BOLT        | VIS 6 PANS        | TORNILLO HEXAGONAL | M10X 30 DIN 933- 2-2-A4C |     |     |
| 19       | 112 6329  | 2          | SCHEIBE           | DISC/PANE/PLATE | RONDELLE/DISQUE   | DISCO              | A 8,4DIN 9023 V2KC       |     |     |
| 20       | 110 7359  | 2          | FLUEGELMUTTER     | WING NUT        | ECROU A AILETTES  | TUERCA MARIPOSA    | M 2DIN 315-G-6T-A4C      |     |     |
| 21       | 238 6973  | 1          | RUECKENPOLSTER    | BACK PAD        | SELLERIE DOSSIER  | TAPIZADO RESPALDO  |                          |     |     |
| 23       | 231 0916  | 4          | BUECHSE           | BUSH            | BOITE             | CASQUILLO          |                          |     |     |
| 24       | 233 3444  | 2          | ROLLE             | ROLLER          | ROULEAU/GALET     | RODILLO/POLEA      |                          |     |     |
| 25       | 238 6982  | 1          | SITZSCHWINGE      | SEAT WING       | BRAS SUPP SIEGE   | BRAZO PORTAASIENTO |                          |     |     |
| 26       | 231 0080  | 1          | PUFFER            | BUFFER/MOUNT    | TAMPON            | TOPE               |                          |     |     |
| 27       | 238 6978  | 1          | SITZPOLSTER       | SEAT PAD        | REMBOURRAGE       | TAPIZADO ASIENTO   |                          |     |     |

| Bld<br>Nr. | Teile-Nr. | Stück-<br>Zahl | Deutsch           | English        | Français           | Español                       | Nummer/Bemerkung  | ETK |
|------------|-----------|----------------|-------------------|----------------|--------------------|-------------------------------|-------------------|-----|
| 28         | 238 6710  | 15             | KLEMME            | CLAMP/CLIP     | BORNE/PINCE        | BORNE/PINZA                   |                   |     |
| 29         | 238 2800  | 1              | KOMFORTSITZ       | COMFORT SEAT   | SIEGE TOUT CONFORT | ASIEN TO CONFORT              | B337-VOLLSTAENDIG |     |
| 35         | 111 7929  | 1              | SICHERUNGSSCHEIBE | LOCKING WASHER | RONDELLE SECURITE  | ARANDELA SEGURIDAD ? DIN 6799 |                   |     |
| 46         | 238 6989  | 1              | GEHAEUSE          | HOUSING/CASE   | CARTER/BOITIER     | CAJA/BLOQUE/CUERPO            |                   |     |





**FAHRERSITZ HÖHENVERSTELLBAR  
OPERATOR'S SEAT VERTICALLY ADJUSTABLE  
SIEGE DE CONDUCTEUR REGLABLE EN HAUTEUR  
ASIENTO DE CONDUCTOR DE ALTURA VARIABLE**

1001-54 501 7168

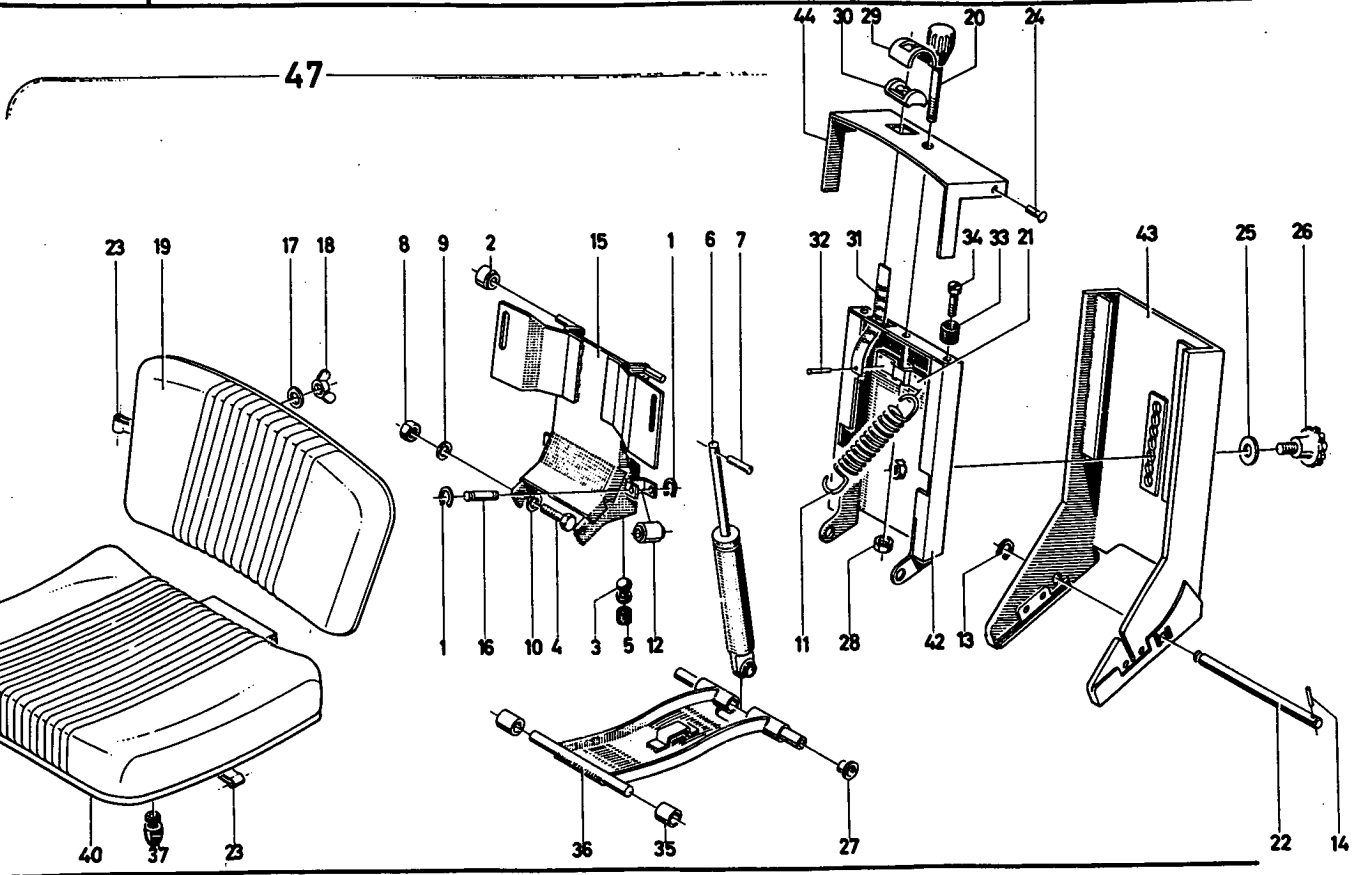

1001-54 501 7168

| Bild Nr. | Teil-Nr. | Stück-Zahl | Deutsch           | English         | Français          | Español            | Nummer/Bemerkung         | ETK |
|----------|----------|------------|-------------------|-----------------|-------------------|--------------------|--------------------------|-----|
| 1        | 112 6001 | 4          | SICHERUNGSSCHEIBE | LOCKING WASHER  | RONDELLE SECURITE | ARANDELA SEGURIDAD | 5 DIN 6799-B2            |     |
| 2        | 233 8053 | 2          | ROLLE             | ROLLER          | ROULEAU/GALET     | RODILLO/POLEA      |                          |     |
| 3        | 111 8415 | 2          | HÖHLENIET         | HOLLOW RIVET    | RIVET CREUX       | REMACHE HUECO      | A4X13X12DIN 7331 VERZK   |     |
| 4        | 111 2429 | 2          | SECHSKANTSCHRAUBE | HEX-BOLT        | VIS 6 PANS        | TORNILLO HEXAGONAL | M10X 30 DIN 933- 8-8-A4C |     |
| 5        | 231 2286 | 2          | PUFFER            | BUFFER/MOUNT    | TAMPON            | TOPE               |                          |     |
| 6        | 233 3447 | 1          | STOSSDÄMPFER      | SHOCK ABSORBER  | AMORTISSEUR       | AMORTIGUADOR       |                          |     |
| 7        | 110 4188 | 1          | ROHRNIET          | TUBULAR RIVET   | RIVET TUBULAIRE   | REMACHE HUECO      | 8X10-75X25DIN 7340-ST    |     |
| 8        | 110 2756 | 2          | SECHSKANTMUTTER   | HEX-NUT         | ECROU 6 PANS      | TUERCA HEXAGONAL   | M10 DIN 985- 8 VZKC      |     |
| 9        | 110 7105 | 2          | SCHEIBE           | DISC/PANE/PLATE | RONDELLE/DISQUE   | DISCO              | A10-5DIN 125-ST-A4C      |     |
| 10       | 110 7110 | 2          | SCHEIBE           | DISC/PANE/PLATE | RONDELLE/DISQUE   | DISCO              | A13 DIN 125-ST-A4C       |     |
| 11       | 233 3448 | 2          | ZUGFEDER          | DRAW SPRING     | RESSORT TRACTION  | RESORTE TRACCION   |                          | 01  |
| 12       | 237 4946 | 2          | ROLLE             | ROLLER          | ROULEAU/GALET     | RODILLO/POLEA      |                          |     |
| 13       | 111 7930 | 1          | SICHERUNGSSCHEIBE | LOCKING WASHER  | RONDELLE SECURITE | ARANDELA SEGURIDAD | 9 DIV 6799               |     |
| 14       | 111 5423 | 2          | SPANNHUELSE       | DOWEL SLEEVE    | DOUILLE SERRAGE   | CASQUILLO FIADOR   | 4 X 24DIN 1461           |     |
| 15       | 238 6974 | 1          | RUECKLEHNRAHMEN   | BACKREST FRAME  | CADRE DE DOSSIER  | MARCO RESP-ASIENTO |                          |     |
| 16       | 237 4948 | 2          | BOLZEN            | PIN/BOLT/STUD   | BOULON/AXE        | BULON              |                          |     |
| 17       | 112 6329 | 2          | SCHEIBE           | DISC/PANE/PLATE | RONDELLE/DISQUE   | DISCO              | A 8-4DIN 9023 VZKC       |     |
| 18       | 110 7359 | 2          | FLUEGELMUTTER     | WING NUT        | ECROU A AILETTES  | TUERCA MARIPOSA    | M 8DIN 315-6-GT-A4C      |     |
| 19       | 238 6973 | 1          | RUECKENPOLSTER    | BACK PAD        | SELLERIE DOSSIER  | TAPIZADO RESPALDO  |                          |     |
| 20       | 237 4943 | 1          | VERSTELLSPINDEL   | SPINDLE         | BROCHE REGLAGE    | MUSILLO GRADUACION |                          |     |
| 21       | 237 4944 | 1          | FEDERBOCK         | SPRING BRACKET  | MAIN DE RESSORT   | CABALL-PORTABALLES |                          |     |
| 22       | 237 4945 | 1          | BOLZEN            | PIN/BOLT/STUD   | BOULON/AXE        | BULON              |                          |     |
| 23       | 238 6710 | 15         | KLENME            | CLAMP/CLIP      | BORNE/PINCE       | BORNE/PINZA        |                          |     |
| 24       | 237 4951 | 2          | BLINDNIET         | BLANK RIVET     | RIVET BORNE       | REMACHE CIEGO      |                          |     |
| 25       | 110 7117 | 1          | SCHEIBE           | DISC/PANE/PLATE | RONDELLE/DISQUE   | DISCO              | A17 DIN 125-ST-A4C       |     |
| 26       | 237 4952 | 1          | VERSTELLSPINDEL   | SPINDLE         | BROCHE REGLAGE    | MUSILLO GRADUACION |                          |     |

| Bid Nr. | Teil-Nr. | Stück-Zahl | Deutsch           | English            | Français           | Español            | Nummer/Bemerkung      | ETK |
|---------|----------|------------|-------------------|--------------------|--------------------|--------------------|-----------------------|-----|
| 27      | 231 0918 | 4          | BUECHSE           | BUSH               | BOITE              | CASQUILLO          |                       |     |
| 28      | 110 8066 | 1          | SECHSKANTMUTTER   | HEX-NUT            | ECROU 6 PANS       | TUERCA HEXAGONAL   | M12 DIN 555           |     |
| 29      | 237 4954 | 1          | HAUBE             | HOOD               | CAPOT/BONNET       | CAPERUZA/CAPOT     |                       |     |
| 30      | 237 4955 | 1          | FUEHRUNG          | GUIDE              | GUIDE/CONDUITE     | GUIA/CONDUCCION    |                       |     |
| 31      | 237 4956 | 1          | ANZEIGER          | INDICATOR          | INDICATEUR         | INDICADOR          |                       |     |
| 32      | 111 5316 | 1          | HALBRUNDKERBNAGEL | NOTCHED NAIL       | ERGOT A ENCOCHE    | CLAVIJA RANURADA   | 4 X 5 DIN 1476 VZKC   |     |
| 33      | 237 4957 | 2          | PUFFER            | BUFFER/MOUNT       | TAMPON             | TOPE               |                       |     |
| 34      | 112 8250 | 2          | BLECHSCHRAUBE     | SELF-TAPPING SCREW | VIS                | TORNILLO CHAPA     | B 4.3X22 DIN 7971-A4C |     |
| 35      | 233 3444 | 2          | ROLLE             | ROLLER             | ROULEAU/GALET      | RODILLO/POLEA      |                       |     |
| 36      | 238 6981 | 1          | SCHWINGE          | SHACKLE            | BALANCIER          | BALANCIÓN/PLUMA    |                       |     |
| 37      | 231 0080 | 1          | PUFFER            | BUFFER/MOUNT       | TAMPON             | TOPE               |                       |     |
| 40      | 238 6978 | 1          | SITZPOLSTER       | SEAT PAD           | REMBOURRAGE        | TAPIZADO ASIENTO   |                       |     |
| 42      | 238 6985 | 1          | GEHAEUSE          | HOUSING/CASE       | CARTER/BOITIER     | CAJA/BLOQUE/CUERPO |                       |     |
| 43      | 238 6986 | 1          | GEHAEUSE          | HOUSING/CASE       | CARTER/BOITIER     | CAJA/BLOQUE/CUERPO |                       |     |
| 44      | 238 6987 | 1          | BLLENDE           | FRAME              | ECRAN/PARASOLEIL   | DIAFRAGMA          |                       |     |
| 47      | 238 2799 | 1          | KOMFORTSITZ       | COMFORT SEAT       | SIEGE TOUT CONFORT | ASIENTO CONFORT    | B337-VOLLSTAENDIG     |     |

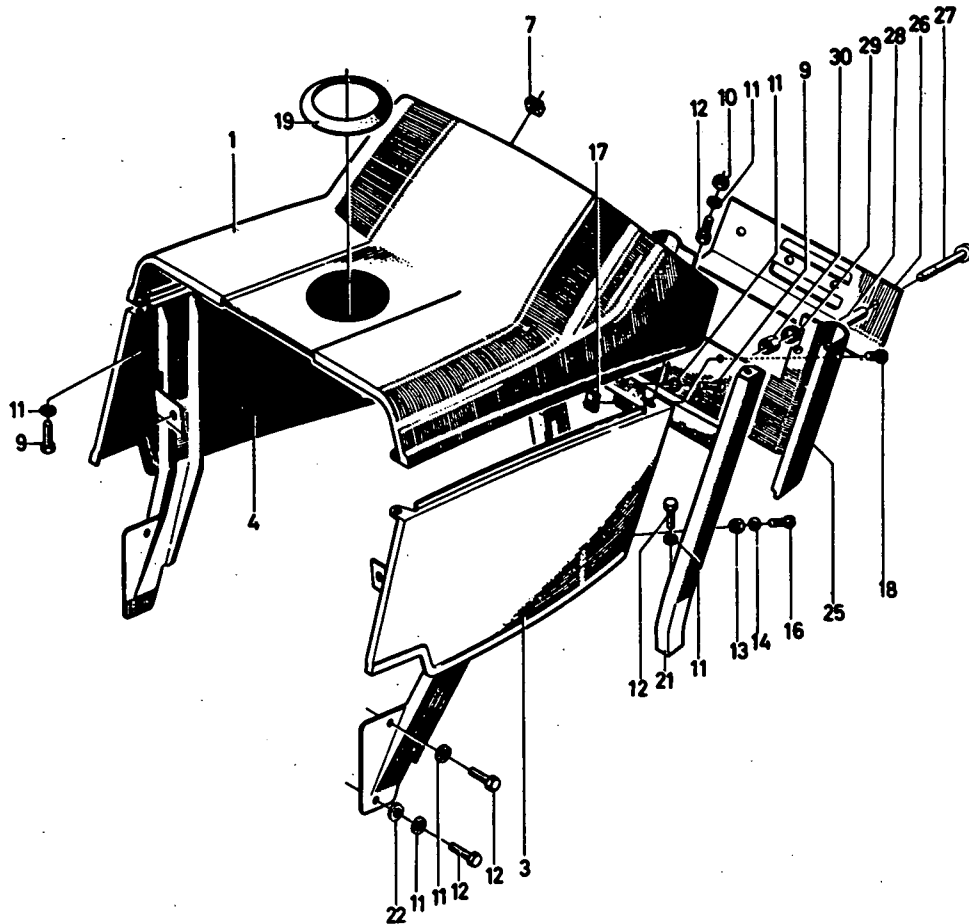

1001-55 500 3021

| Bld Nr. | Teile-Nr. | Stück-Zahl | Deutsch           | English            | Français           | Español            | Nummer/Bemerkung            | ETK |
|---------|-----------|------------|-------------------|--------------------|--------------------|--------------------|-----------------------------|-----|
| 1       | 230 4865  | 1          | VERKLEIDUNG       | SHEETING/PANELLING | HABILLAGE          | REVESTIMIENTO      |                             |     |
| 3       | 230 4111  | 1          | VERKLEIDUNG       | SHEETING/PANELLING | HABILLAGE          | REVESTIMIENTO      |                             |     |
| 4       | 230 4112  | 1          | VERKLEIDUNG       | SHEETING/PANELLING | HABILLAGE          | REVESTIMIENTO      |                             |     |
| 7       | 116 7180  | 2          | MUTTER            | NUT                | ECROU              | TUERCA             | M 6/8 2189                  |     |
| 9       | 111 2299  | 3          | SECHSKANTSCHRAUBE | HEX-BOLT           | VIS 6 PANS         | TORNILLO HEXAGONAL | M 8 X 12 DIN 933- 8-8-ANC   |     |
| 10      | 110 8064  | 2          | SECHSKANTMUTTER   | HEX-NUT            | ECROU 6 PANS       | TUERCA HEXAGONAL   | M 8 DIN 555 VZKC            |     |
| 11      | 116 9689  | 11         | SICHERUNGSSCHEIBE | LOCKING WASHER     | RONDELLE SECURITE  | ARANDELA SEGURIDAD | 8 H 2203                    |     |
| 12      | 111 2305  | 8          | SECHSKANTSCHRAUBE | HEX-BOLT           | VIS 6 PANS         | TORNILLO HEXAGONAL | M 8 X 15 DIN 933- 8-8-ANC   |     |
| 13      | 111 2796  | 2          | SECHSKANTMUTTER   | HEX-NUT            | ECROU 6 PANS       | TUERCA HEXAGONAL   | M 4 DIN 934-M 8 ANC         |     |
| 14      | 110 7089  | 2          | SCHIEBE           | DISC/PANE/PLATE    | RONDELLE/DISQUE    | DISCO              | A 5.3DIN 125-ST-ANC         |     |
| 16      | 111 9630  | 2          | LINSENSCHRAUBE    | FILL.-HEAD SCREW   | VIS GOUTTE DE SUIF | TORN-CAB-LENTICUL. | M 4 X 15 DIN 7985- 4-8 VZKC |     |
| 17      | 230 4481  | 1          | BLECHMUTTER       | NUT                | ECROU A TOLE       | TUERCA P-CHAPA     |                             |     |
| 18      | 110 1957  | 1          | LINSENKSCHEIBE    | OVAL-HEAD SCREW    | VIS A BOIS NOYEE   | TORN-CAB-EMBUTID.  | B 5.5X19 DIN 7981 VZKC      |     |
| 19      | 338 8584  | 1          | TUELLE            | GROMMET            | DOUILLE            | FUNDA              | 1135-42-01-35               | 01  |
| 21      | 237 2972  | 1          | STUETZE           | SUPPORT            | SUPPORT/APPUJ      | APOYO              |                             |     |
| 22      | 110 7101  | 2          | SCHIEBE           | DISC/PANE/PLATE    | RONDELLE/DISQUE    | DISCO              | A 8.4DIN 125-ST-ANC         |     |
| 25      | 238 1822  | 1          | ABSCHLUSSKAPPE    | CAP                | CAPUCHON OBTURAT   | CAPUCHON CIERRE    |                             |     |
| 26      | 237 6244  | 1          | BLLENDE           | FRAME              | ECRAN/PARASOLEIL   | DIAFRAGMA          |                             |     |
| 27      | 112 3048  | 2          | LINSENSCHRAUBE    | FILL.-HEAD SCREW   | VIS GOUTTE DE SUIF | TORN-CAB-LENTICUL. | M 5 X 35 DIN 7985- 4-8 ANC  |     |
| 28      | 238 1833  | 2          | ROHR              | PIPE/TUBE          | TUBE/TUYAU         | TUBO               |                             |     |
| 29      | 116 7193  | 2          | SICHERUNGSSCHEIBE | LOCKING WASHER     | RONDELLE SECURITE  | ARANDELA SEGURIDAD | 5 H 2203                    |     |
| 30      | 111 2803  | 2          | SECHSKANTMUTTER   | HEX-NUT            | ECROU 6 PANS       | TUERCA HEXAGONAL   | M 5 DIN 934-M 8 ANC         |     |

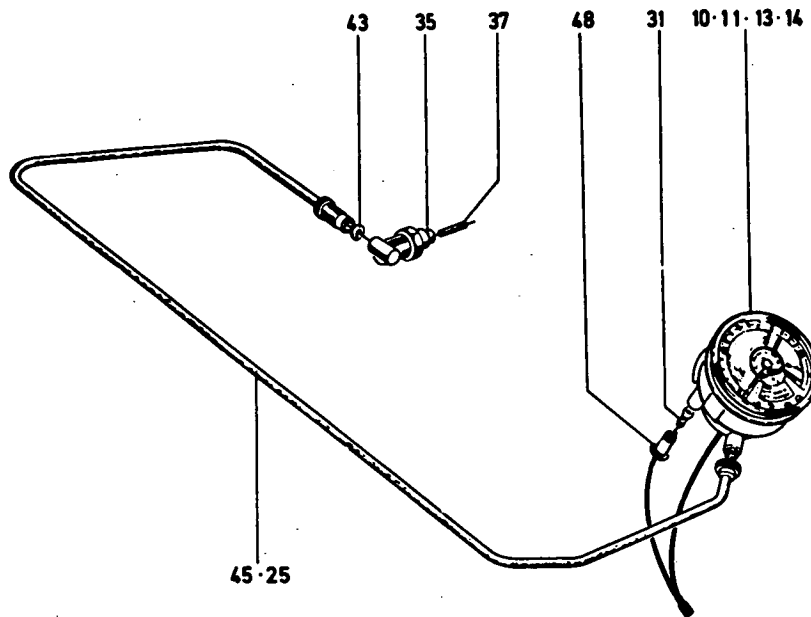

1001-56 500 4237

| Bild Nr. | Teil-Nr. | Stück-Zahl | Deutsch        | English         | Français           | Español           | Nummer/Bemerkung                                       | ETK |
|----------|----------|------------|----------------|-----------------|--------------------|-------------------|--|-----|
| 10       | 238 6623 | 1          | TRAKTORMETER   | TRACTORMETER    | TRACTOMETRE        | TRACTOMETRO       | 9T100X2500X45 H 4260<br>KM/H·TW 35-2/2300              |     |
| 11       | 238 6623 | 1          | TRAKTORMETER   | TRACTORMETER    | TRACTOMETRE        | TRACTOMETRO       | 10T100X2500X45 H 4260<br>MPH·TW 35-2 S/2300            |     |
| 13       | 238 6617 | 1          | TRAKTORMETER   | TRACTORMETER    | TRACTOMETRE        | TRACTOMETRO       | 13T100X2500X45 H 4260<br>KM/H·TW 35.4 TW 50-1/2/3-2300 |     |
| 14       | 238 6619 | 1          | TRAKTORMETER   | TRACTORMETER    | TRACTOMETRE        | TRACTOMETRO       | 14T100X2500X45 H 4260<br>MPH·TW 35.4 TW 50-1/2/3-2300  |     |
| 25       | 232 5481 | 1          | BIEGSAME-WELLE | FLEXIBLE SHAFT  | ARBRE FLEXIBLE     | EJE FLEXIBLE      | 8367-ZU P0S-35   |     |
| 31       | 112 1438 | 1          | GLUEHLAMPE     | LIGHT BULB      | LAMPE A INCANDESC  | BOMBILLA          | H 12V 2 W DIN72601                                     | 01  |
| 35       | 116 8559 | 1          | WINKELGETRIEBE | ANGLE DRIVE     | ENGRENAGE ANGUL.   | ENGRANAJE ANGULAR | 22E H 4217   |     |
| 37       | 121 6889 | 1          | MITNEHMER      | DRIVER/ACTUATOR | ENTRAINEUR/TOC     | ARRASTADOR        | 4 217 B 6  |     |
| 43       | 111 8669 | 1          | DICHTRING      | WASHER          | BAGUE D ETANCHEITE | ANILLO DE JUNTA   | A 10 X 16 DIN 7603-CU                                  |     |
| 45       | 233 7887 | 1          | BIEGSAME-WELLE | FLEXIBLE SHAFT  | ARBRE FLEXIBLE     | EJE FLEXIBLE      |  |     |
| 48       | 121 0197 | 1          | LAMPENFASSUNG  | LAMP SOCKET     | DOUILLE D AMPOULE  | PORTALAMPARA      | 7 645 B 1  |     |

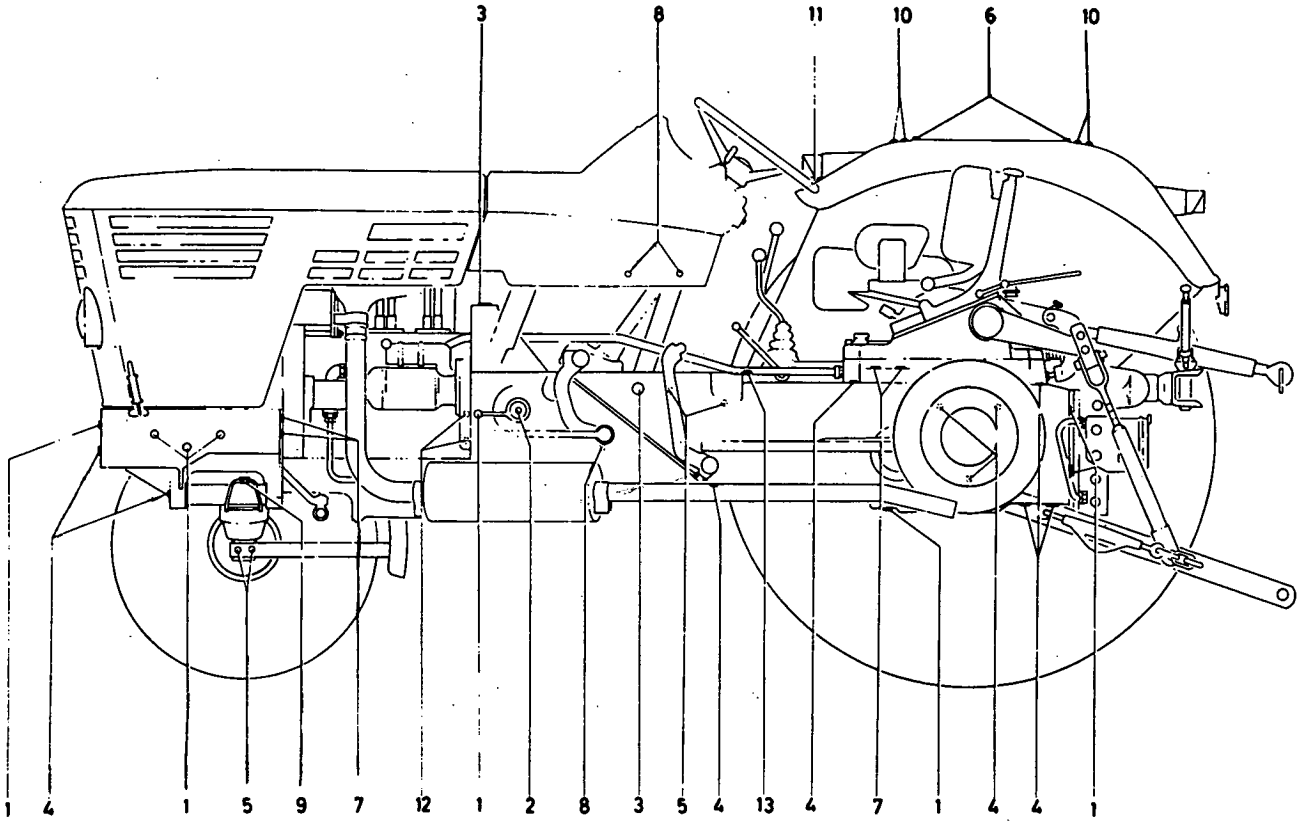

1001-57 500 5374

| Bld Nr. | Teil-Nr. | Stück-Zahl | Deutsch           | English | Français | Español         | Nummer/Bemerkung    | ETK |
|---------|----------|------------|-------------------|---------|----------|-----------------|---------------------|-----|
| 1       | 116 7316 | 14         | VERSCHLUSSSTOPFEN | NIPPLE  | BOUCHON  | TAPON OBTURADOR | A14 H 2573          |     |
| 2       | 116 7333 | 2          | VERSCHLUSSSTOPFEN | NIPPLE  | BOUCHON  | TAPON OBTURADOR | A41 H 2873          |     |
| 3       | 116 1302 | 2          | VERSCHLUSSSTOPFEN | NIPPLE  | BOUCHON  | TAPON OBTURADOR | A25.5 H 2873        |     |
| 4       | 116 7314 | 18         | VERSCHLUSSSTOPFEN | NIPPLE  | BOUCHON  | TAPON OBTURADOR | A12 H 2873          |     |
| 5       | 116 7311 | 6          | VERSCHLUSSSTOPFEN | NIPPLE  | BOUCHON  | TAPON OBTURADOR | A 9 H 2573          |     |
| 6       | 231 1492 | 4          | STOPFEN           | PLUG    | BOUCHON  | TAPON           |                     |     |
| 7       | 116 7308 | 4          | VERSCHLUSSSTOPFEN | NIPPLE  | BOUCHON  | TAPON OBTURADOR | A 7 H 2873          |     |
| 8       | 116 7312 | 4          | VERSCHLUSSSTOPFEN | NIPPLE  | BOUCHON  | TAPON OBTURADOR | A10.5 H 2873        |     |
| 9       | 116 7323 | 2          | VERSCHLUSSSTOPFEN | NIPPLE  | BOUCHON  | TAPON OBTURADOR | A19 H 2573          |     |
| 10      | 116 9031 | 8          | VERSCHLUSSSTOPFEN | NIPPLE  | BOUCHON  | TAPON OBTURADOR | 1H10 X14 X 7 H 7565 |     |
| 11      | 116 9032 | 2          | VERSCHLUSSSTOPFEN | NIPPLE  | BOUCHON  | TAPON OBTURADOR | 1H14 X15 X 8 H 7565 |     |
| 12      | 116 7315 | 4          | VERSCHLUSSSTOPFEN | NIPPLE  | BOUCHON  | TAPON OBTURADOR | A12.5 H 2873        |     |
| 13      | 116 3522 | 1          | VERSCHLUSSSTOPFEN | NIPPLE  | BOUCHON  | TAPON OBTURADOR | A16.5X 9 H 2873     |     |



SCHEIBENRÄDER, VORN  
 DISC WHEELS, FRONT  
 ROUES A VOILE PLEIN AV  
 RUEDAS DE PLATO DELANTERAS

1001-58 502 2720

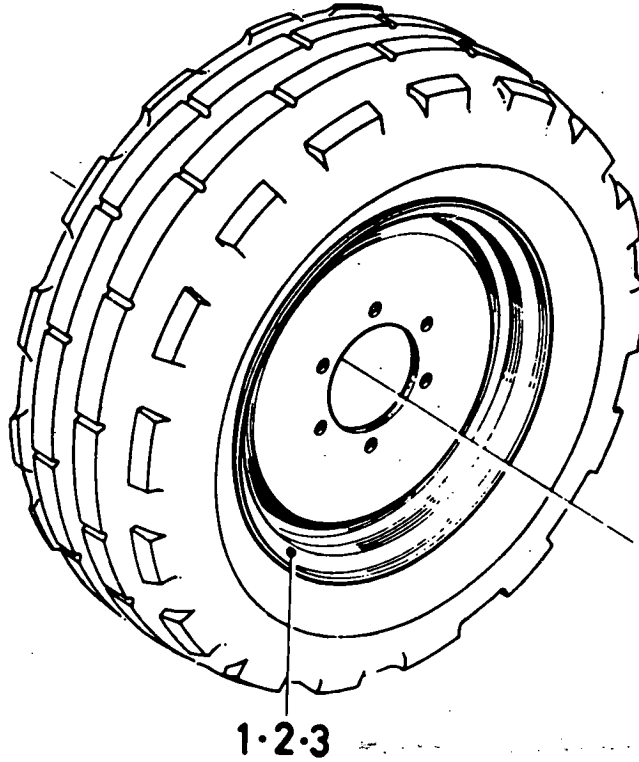

1001-58 502 2720

| Bild Nr. | Teil-Nr. | Stück-Zahl | Deutsch     | English    | Français    | Español        | Nummer/Bemerkung  | ETK |
|----------|----------|------------|-------------|------------|-------------|----------------|---|-----|
| 1        | 116 1032 | 2          | SCHEIBENRAD | DISC WHEEL | ROUE PLEINE | RUEDA DE PLATO | 5.50FX16-205X12X (H 7331<br>8094-FUER BEREIFUNG<br>7.50-16 EX-SPEZ MM 6 PLY<br>7.50-16 EX-SPEZ HS 6 PLY               |     |
| 2        | 237 7464 | 2          | SCHEIBENRAD | DISC WHEEL | ROUE PLEINE | RUEDA DE PLATO | 8094-FUER BEREIFUNG<br>6.00-16 AS/FR 6 PLY<br>6.00-16 AS/FR 6 PLY TL<br>5.50-16 AS/FR 6 PLY<br>5.50-16 AS/FR 6 PLY TL |     |
| 3        | 237 7465 | 2          | SCHEIBENRAD | DISC WHEEL | ROUE PLEINE | RUEDA DE PLATO | 8094-FUER BEREIFUNG<br>6.50-16 AS/FR 6 PLY<br>6.50-16 AS/FR 6 PLY TL  |     |



SCHEIBENRÄDER, HINTEN  
 REAR DISK WHEELS  
 RUES A VOILE PLEIN  
 RUEDAS DE PLATO, ATRAS

1001-59 502 2721

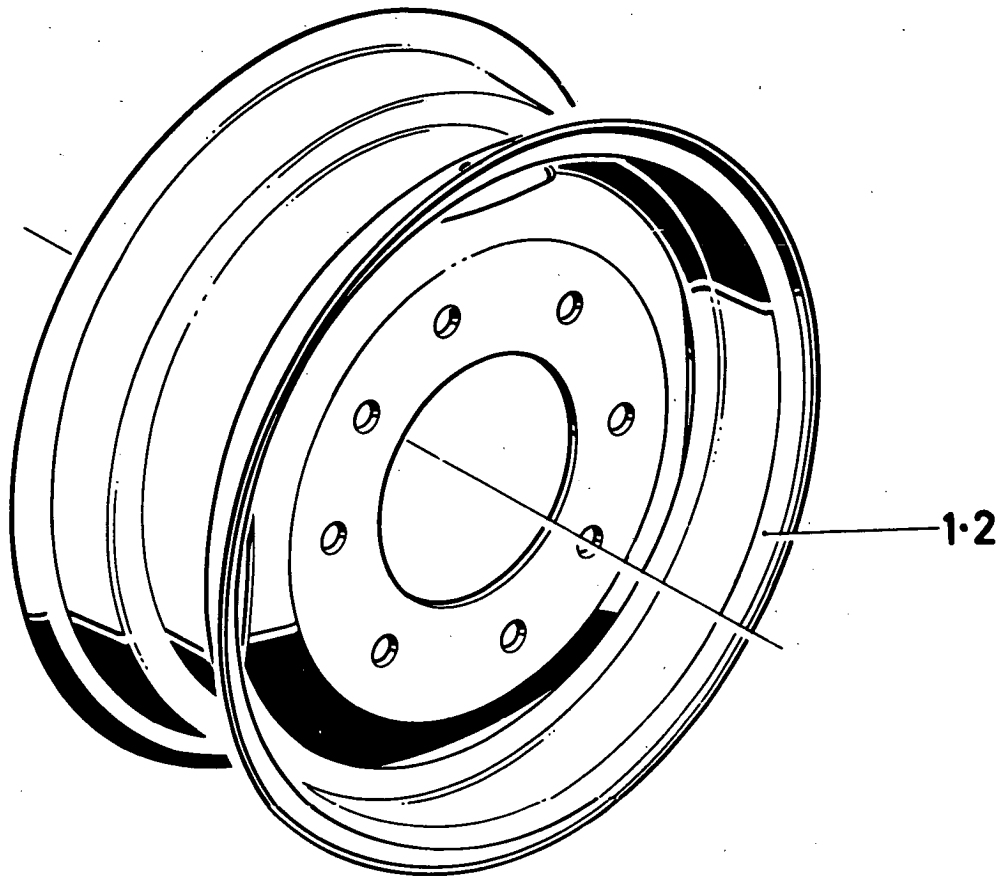

| Bild Nr. | Teile-Nr. | Stück-Zahl | Deutsch     | English    | Français    | Español        | 1001-59 502 2721<br>Nummer/Bemerkung                                   | ETK |
|----------|-----------|------------|-------------|------------|-------------|----------------|--|-----|
| 1        | 116 8865  | 2          | SCHEIBENRAD | DISC WHEEL | ROUE PLEINE | RUEDA DE PLATO | 1W10X32-205X18X56 H 7331<br>8094-FUER BEREIFUNG<br>12.4/11-32 AS 6 PLY |     |
| 2        | 116 8863  | 2          | SCHEIBENRAD | DISC WHEEL | ROUE PLEINE | RUEDA DE PLATO | 1W 8 X36-205X18X 56H 7331<br>8094-FUER BEREIFUNG<br>9.5/9-36 AS 6 PLY  |     |



**VERSTELLRÄDER  
BOWL WHEELS ADJUSTABLE-GAUGE  
ROUES A GRADINS  
RUEDAS DE MODIFICACION DE ANCHO DE RODADA**

1001-59 502 2722

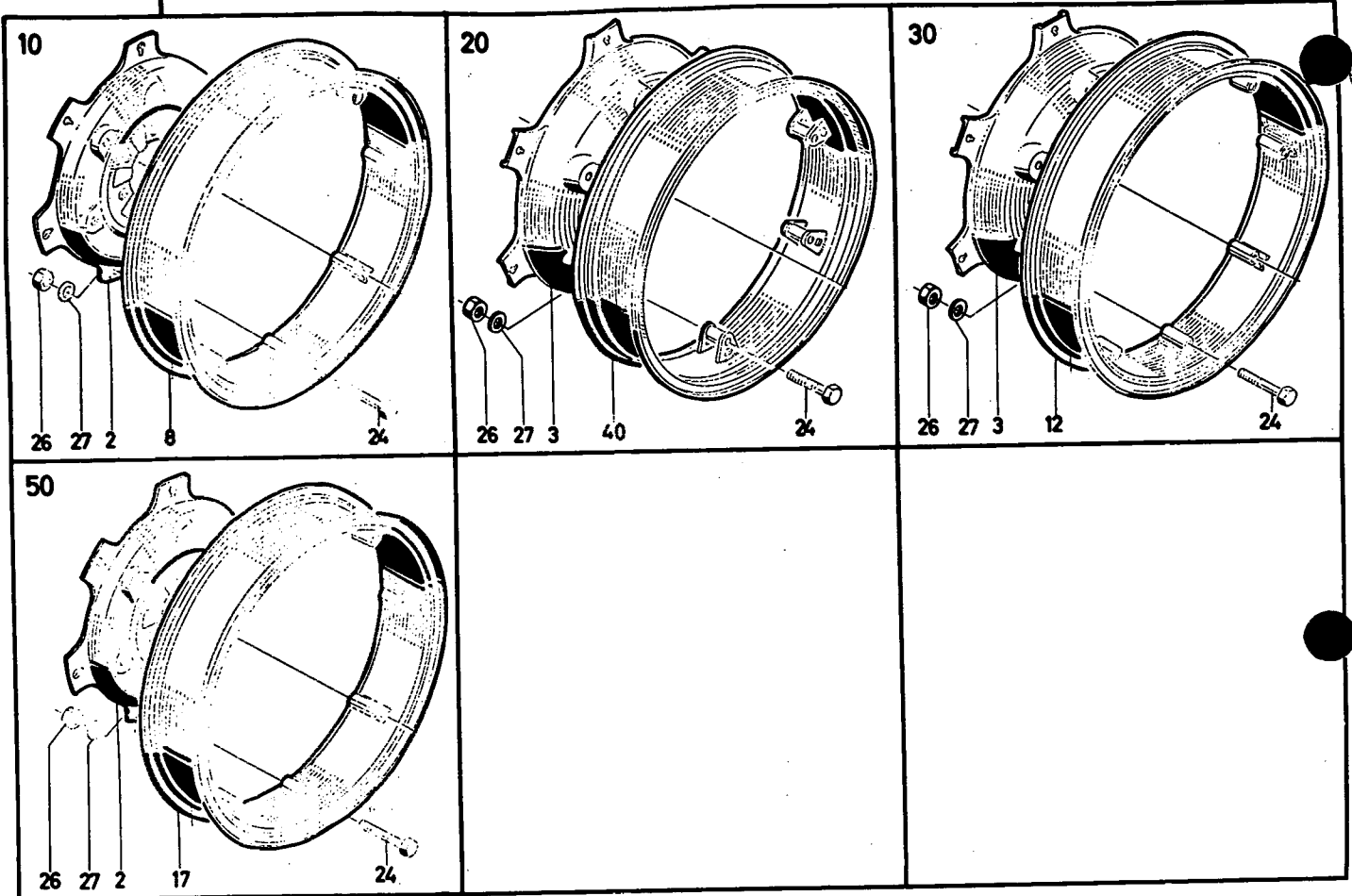

1001-59 502 2722

| Bld Nr. | Teile-Nr. | Stück-Zahl | Deutsch           | English           | Français           | Español            | Nummer/Bemerkung   | ETK | IT |
|---------|-----------|------------|-------------------|-------------------|--------------------|--------------------|--|-----|----|
| 2       | 116 8859  | 2          | VERSTELLSCHWESSEL | ADJUST-BOWL       | FLASQUE ROUE GRAD. | PLATO MODIF.RODADA | 205X18X6X100X6CB E H 7339  |     |    |
| 3       | 116 8871  | 2          | VERSTELLSCHWESSEL | ADJUST-BOWL       | FLASQUE ROUE GRAD. | PLATO MODIF.RODADA | 205X18X6X100X7CB EE H 7339   |     |    |
| 8       | 116 8883  | 2          | VERSTELLFELGE     | ADJUSTABLE RIM    | JANTE REGLABLE     | ARO RUDE-ANCHO VAR | W10 X28 X100X6CB XE H 7340   |     |    |
| 10      | 116 0252  | IP         | VERSTELLRAD       | ADJUST-WHEEL/GEAR | ROUE DE REGLAGE    | RUEDA GRADUACION   | W10 X28 X205X E H 7341<br>8794.FUER BEBEIFUNG<br>33.6/12-28 AS E PLY |     |    |
| 12      | 116 8881  | 2          | VERSTELLFELGE     | ADJUSTABLE RIM    | JANTE REGLABLE     | ARO RUDE-ANCHO VAR | W 10X32X100X70F.5X6 H 7340   |     |    |
| 17      | 116 9947  | 2          | VERSTELLFELGE     | ADJUSTABLE RIM    | JANTE REGLABLE     | ARO RUDE-ANCHO VAR | W12X24X100X65A6 F 7340   |     |    |
| 20      | 116 0255  | IP         | VERSTELLRAD       | ADJUST-WHEEL/GEAR | ROUE DE REGLAGE    | RUEDA GRADUACION   | W 8 X36 X205X E H 7341<br>8794.FUER BEBEIFUNG<br>33.6/12-36 AS E PLY |     |    |
| 24      | 121 8413  | 12         | SCHRAUBE          | SCREW/BOLT        | VIS/BOULON         | TORNILLO           | 2014 9 7   |     |    |
| 26      | 110 0169  | 12         | SECHSKANTMUTTER   | HEX-NUT           | ECPON E PANS       | TUERCA HEXAGONAL   | M 14X1.5 DIN 934 PIC ANC   |     |    |
| 27      | 121 6134  | 12         | SCHEIBE           | DISC/PANE/PLATE   | RONDELLE/DISQUE    | DISCO              | 2708 A 36  |     |    |
| 30      | 116 0256  | IP         | VERSTELLRAD       | ADJUST-WHEEL/GEAR | ROUE DE REGLAGE    | RUEDA GRADUACION   | W10 X32 X205X E H 7341<br>8794.FUER BEBEIFUNG<br>33.6/12-32 AS E PLY |     |    |
| 40      | 238 1576  | 2          | VERSTELLFELGE     | ADJUSTABLE RIM    | JANTE REGLABLE     | ARO RUDE-ANCHO VAR | W4X34X209.5X6  |     |    |
| 50      | 116 0257  | IP         | VERSTELLRAD       | ADJUST-WHEEL/GEAR | ROUE DE REGLAGE    | RUEDA GRADUACION   | W12 X34 X205X E H 7341<br>8794.FUER BEBEIFUNG<br>34.6/12-34 AS E PLY |     |    |



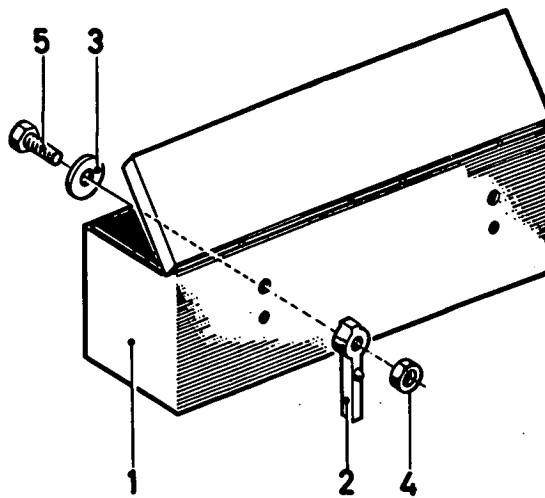

1001-60 500 3024

| Bild Nr. | Teile-Nr. | Stück-Zahl | Deutsch           | English         | Français           | Español            | Nummer/Bemerkung         | ETK |
|----------|-----------|------------|-------------------|-----------------|--------------------|--------------------|--------------------------|-----|
| 1        | 230 6803  | 1          | WERKZEUGKASTEN    | TOLLBOX         | BOITE A OUTILS     | CAJA HERRAMIENTAS  |                          |     |
| 2        | 230 6797  | 2          | ZWISCHENSTUECK    | ADAPTER         | PIECE INTERCALAIRE | PIEZA INTERMEDIA   |                          |     |
| 3        | 230 8040  | 2          | SCHEIBE           | DISC/PANE/PLATE | RONDELLE/DISQUE    | DISCO              |                          |     |
| 4        | 110 2659  | 2          | SECHSKANTMUTTER   | HEX-NUT         | ECROU 6 PANS       | TUERCA HEXAGONAL   | M10 DIN 934-M 8 A4C      |     |
| 5        | 111 2423  | 2          | SECHSKANTSCHRAUBE | HEX-BOLT        | VIS 6 PANS         | TORNILLO HEXAGONAL | M10X 28 DIN 933- 8-8-A4C |     |

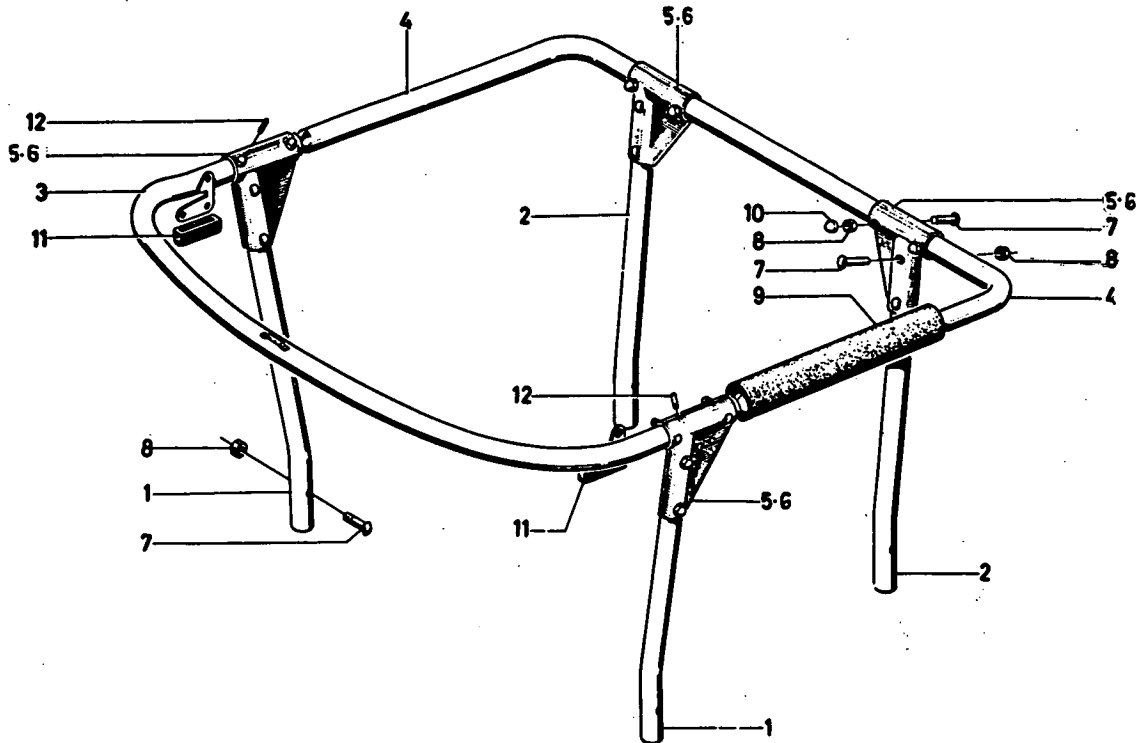

1001-61 500 4240

| Bild Nr. | Teil-Nr. | Stück-Zahl | Deutsch           | English         | Français           | Español            | Nummer/Bemerkung | ETK |
|----------|----------|------------|-------------------|-----------------|--------------------|--------------------|------------------|-----|
| 1        | 233 1121 | 2          | STUETZE           | SUPPORT         | SUPPORT/APPUY      | APOYO              | B346, VORN       |     |
| 2        | 233 1122 | 2          | STUETZE           | SUPPORT         | SUPPORT/APPUY      | APOYO              | B150, HINTEN     |     |
| 3        | 233 1123 | 1          | ROHRBOGEN         | PIPE BEND       | COUDE              | CODO DE TUBO       | B346, VORN       |     |
| 4        | 233 1124 | 1          | ROHRBOGEN         | PIPE BEND       | COUDE              | CODO DE TUBO       | B150, HINTEN     |     |
| 5        | 233 1125 | 4          | KLEMMSCHELLE      | CLIP            | COLLIER DE SERRAGE | ABRAZADERA APRIETO | B195, LINKS      |     |
| 6        | 233 1127 | 4          | KLEMMSCHELLE      | CLIP            | COLLIER DE SERRAGE | ABRAZADERA APRIETO | B267, RECHTS     |     |
| 7        | 232 3037 | 20         | SCHRAUBE          | SCREW/BOLT      | VIS/BOULON         | TORNILLO           |                  |     |
| 8        | 232 3210 | 20         | SECHSKANTMUTTER   | HEX-NUT         | ECROU 6 PANS       | TUERCA HEXAGONAL   |                  |     |
| 9        | 233 3194 | 1          | NACKENSCHUTZ      | NECK PROTECTION | PROTEGE-TETE       | PROTECT-CABEZA     |                  |     |
| 10       | 232 3218 | 12         | SCHUTZKAPPE       | CAP             | CAPUCHON PROTECT   | SOMBRERETE PROTEC. |                  |     |
| 11       | 233 4506 | 2          | SCHUTZKAPPE       | CAP             | CAPUCHON PROTECT   | SOMBRERETE PROTEC. |                  |     |
| 12       | 112 5635 | 2          | ZYLINDERKERBSTIFT | NOTCHED PIN     | GOUPILLE CYL-CRANT | PERNO CIL-PANURADO | 6 X 100IN 1470   |     |

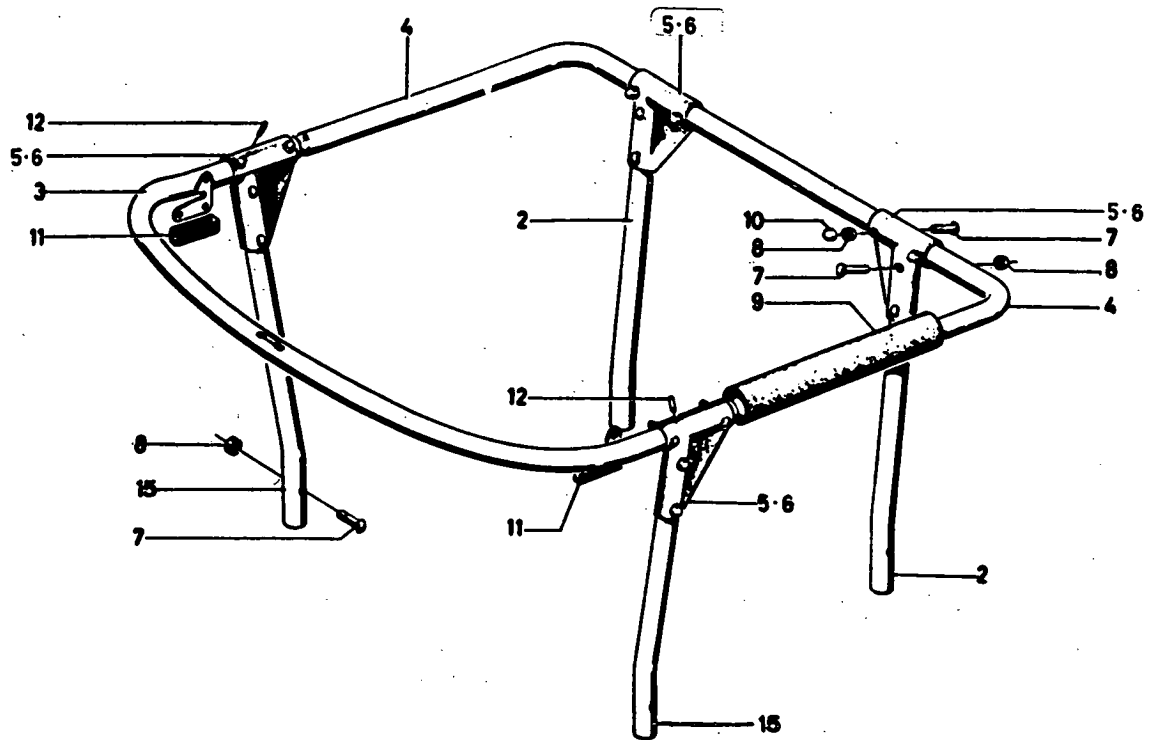

| Bild<br>Nr. | Teil-Nr. | Stück-<br>Zahl | Deutsch           | English         | Français           | Español            | 1001-61 502 0171 |               | ETK | ETK |
|-------------|----------|----------------|-------------------|-----------------|--------------------|--------------------|------------------|---------------|-----|-----|
|             |          |                |                   |                 |                    |                    | Nummer           | Bemerkung     |     |     |
| 2           | 233 1122 | 2              | STUETZE           | SUPPORT         | SUPPORT/APPUI      | APOYO              |                  | 8150-HINTEN   |     |     |
| 3           | 233 1126 | 1              | ROHRBOGEN         | PIPE BEND       | COUDE              | CODO DE TUBO       |                  | 8346-VORN     |     |     |
| 4           | 233 1124 | 1              | ROHRBOGEN         | PIPE BEND       | COUDE              | CODO DE TUBO       |                  | 8150-HINTEN   |     |     |
| 5           | 233 1126 | 4              | KLEMSCHELLE       | CLIP            | COLLIER DE SERRAGE | ABRAZADERA APRIETO |                  | 8195-LINKS    |     |     |
| 6           | 233 1127 | 4              | KLEMSCHELLE       | CLIP            | COLLIER DE SERRAGE | ABRAZADERA APRIETO |                  | 8267-RECHTS   |     |     |
| 7           | 232 3037 | 20             | SCHRAUBE          | SCREW/BOLT      | VIS/BOULON         | TORNILLO           |                  |               |     |     |
| 8           | 232 3210 | 20             | SECHSKANTMUTTER   | HEX-NUT         | ECPON 5 PANS       | TUERCA HEXAGONAL   |                  |               |     |     |
| 9           | 233 3194 | 1              | NACKENSCHUTZ      | NECK PROTECTION | PROTEGE-TETE       | PROTECT-CABEZA     |                  |               |     |     |
| 10          | 232 3216 | 12             | SCHUTZKAPPE       | CAP             | CAPUCHON PROTECT   | SOMBRERETE PROTEC- |                  |               |     |     |
| 11          | 233 4506 | 2              | SCHUTZKAPPE       | CAP             | CAPUCHON PROTECT   | SOMBRERETE PROTEC- |                  |               |     |     |
| 12          | 112 5635 | 2              | ZYLINDERKERBSTIFT | NOTCHED PIN     | GOUPILLE CYL-CRANT | PERNO CIL-RANURADO |                  | 6X10 DIN 1470 |     |     |
| 15          | 236 6341 | 2              | STUETZE           | SUPPORT         | SUPPORT/APPUI      | APOYO              |                  | 8346-VORN     |     |     |

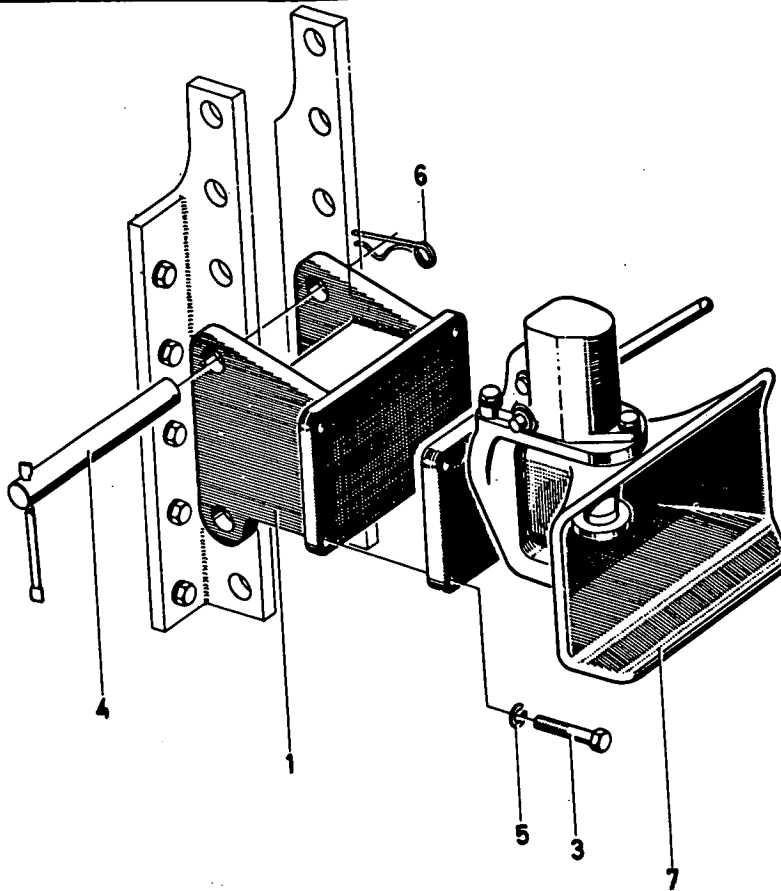

1005-62 500 3026

| Bild-Nr. | Teile-Nr. | Stück-Zahl | Deutsch           | English           | Français          | Español            | Nummer/Bemerkung                       | ETK |
|----------|-----------|------------|-------------------|-------------------|-------------------|--------------------|--|-----|
| 1.       | 231 8008  | 1          | ANHAENGEPLATTE    | TOWING PLATE      | PLAQUE ATTELAGE   | PLACA ENGANCHE     | 1145-62-21-10                          |     |
| 3        | 111 2608  | 4          | SECHSKANTSCHRAUBE | HEX-BOLT          | VIS 6 PANS        | TORNILLO HEXAGONAL | M14X 30 DIN 933-M 8-8 A4C              |     |
| 4        | 338 7618  | 1          | STECKBOLZEN       | COTTER PIN        | CHEVILLE          | BULON ENCHUFE      | 1124-63-04-10                          |     |
| 5        | 110 7240  | 4          | FEDERRING         | SPRING LOCKWASHER | RONDELLE GROUVER  | ARANDELA ELASTICA  | 814 DIN 127 VZKC                       |     |
| 6        | 338 7614  | 1          | SICHERUNGSTIFT    | LOCKING PIN       | GOUPILLE D ARRET  | PERNO AFIANZADOR   | 1124-63-01-07                          |     |
| 7        | 110 1431  | 1          | ANHAENGERKUPPLUNG | TRAILER HITCH     | ATTELAGE REMORQUE | ACOPLE REMOLQUE    | U140DIN740S1<br>ROCKINGER TYP 39/U 140 |     |



ANHÄNGEKUPPLUNG  
TRAILER HITCH, AUTOMATIC, RIGID  
DISPOSITIF D'ATTELAGE  
ACOPLE PARA REMOLQUES

7868/0081

1001-63 500 4260

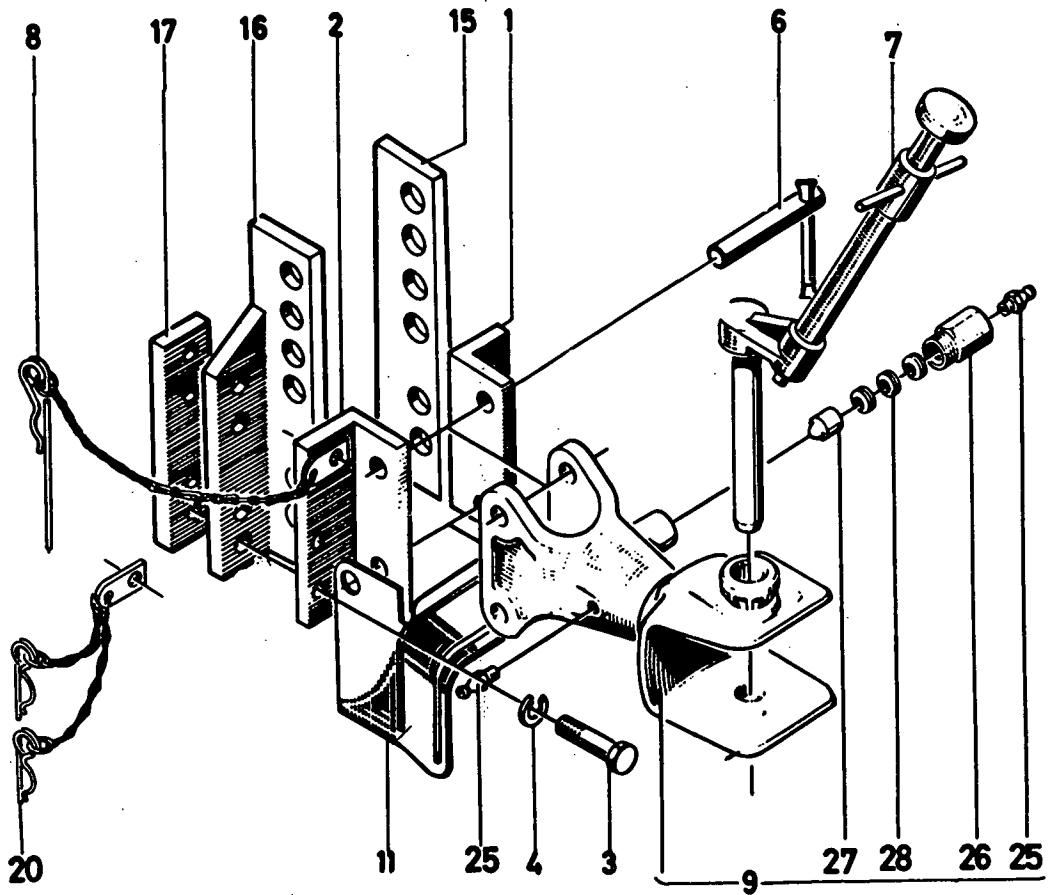

ANHÄNGEKUPPLUNG  
TRAILER HITCH, AUTOMATIC, RIGID  
DISPOSITIF D'ATTELAGE  
ACOPLE PARA REMOLQUES

7876/0854  
7868/0082

1001-63 500 4260

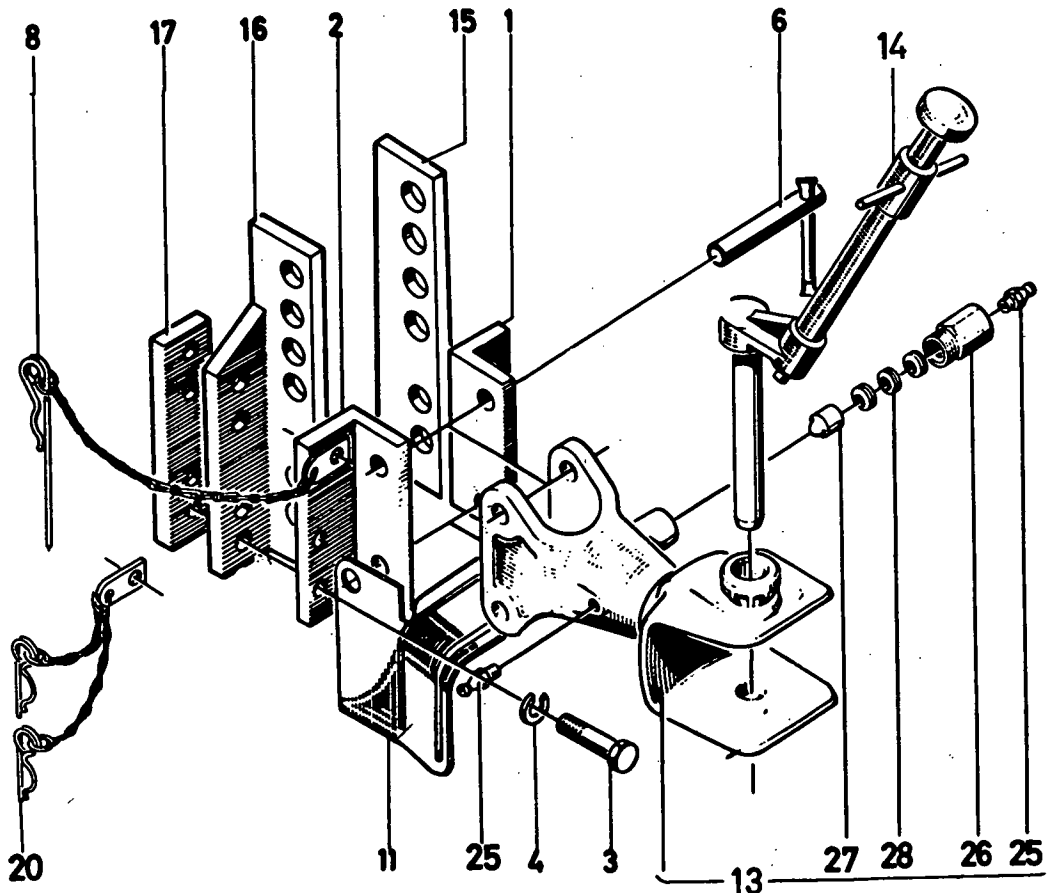

| Bild Nr. | Teil-Nr. | Stück-Zahl | Deutsch            | English           | Français           | Español            | Nummer/Bemerkung          | ETK |
|----------|----------|------------|--------------------|-------------------|--------------------|--------------------|---------------------------|-----|
| 1        | 233 0858 | 1          | FUEHRUNGSLEISTE    | GUIDE RAIL        | BARRE CONDUCTR     | LISTON GUIA        | 8267-RECHTS               |     |
| 2        | 233 0857 | 1          | FUEHRUNGSLEISTE    | GUIDE RAIL        | BARRE CONDUCTR     | LISTON GUIA        | 8195-LINKS                |     |
| 3        | 111 2679 | 4          | SECHSKANTSCHRAUBE  | HEX-BOLT          | VIS 6 PANS         | TORNILLO HEXAGONAL | M16x 35 DIN 933-M 8-8 A4C |     |
| 4        | 110 2803 | 4          | FEDERRING          | SPRING LOCKWASHER | RONDELLE GROMER    | ARANDELA ELASTICA  | A 16 DIN 328 A4C          |     |
| 6        | 338 7618 | 2          | STECKBOLZEN        | COTTER PIN        | CHEVILLE           | BULON ENCHUFE      |                           |     |
| 7        | 233 3286 | 1          | VORSTECKBOLZEN     | COTTER/HITCH PIN  | BROCHE             | PERNO ENGANCHE     |                           |     |
| 8        | 233 0863 | 1          | BOLZENSICHERUNG    | LOCK/COTTER       | FREIN DE BOULON    | AFIANZA-BULON      |                           |     |
| 9        | 233 4251 | 1          | ANHAENGERKUPPLUNG  | TRAILER HITCH     | ATTELAGE REMORQUE  | ACOPLE REMOLQUE    |                           |     |
| 11       | 338 8203 | 1          | MASTERSHIELD       | MASTERSHIELD      | PROTECTEUR PDF     | CUBIERTA PROTECC   |                           |     |
| 13       | 237 1202 | 1          | ANHAENGERKUPPLUNG  | TRAILER HITCH     | ATTELAGE REMORQUE  | ACOPLE REMOLQUE    |                           |     |
| 14       | 233 8979 | 1          | VORSTECKBOLZEN     | COTTER/HITCH PIN  | BROCHE             | PERNO ENGANCHE     |                           |     |
| 15       | 237 6570 | 1          | FUEHRUNGSLEISTE    | GUIDE RAIL        | BARRE CONDUCTR     | LISTON GUIA        |                           |     |
| 16       | 237 6571 | 1          | FUEHRUNGSLEISTE    | GUIDE RAIL        | BARRE CONDUCTR     | LISTON GUIA        |                           |     |
| 17       | 232 4196 | 2          | UNTERLAGE          | PAD/BASE          | CALE/SEMELLE/SUPP. | BASE/APOYO/ASIENTO |                           |     |
| 20       | 338 9898 | 1          | BOLZENSICHERUNG    | LOCK/COTTER       | FREIN DE BOULON    | AFIANZA-BULON      | 8355-WAHLWEISE POS-8      |     |
| 25       | 116 8225 | 2          | KEGELSCHMIERNIPPEL | LUBE FITTING      | GRAISSEUR CONIQUE  | ENGRASADOR CONICO  | SA 8H 3360                |     |
| 26       | 233 5413 | 1          | KAPPE              | CAP               | CAPUCHON/CALOTTE   | SOMBRES-/CAPUCHON  |                           |     |
| 27       | 233 5414 | 1          | FUEHRUNGSROLLE     | GUIDE ROLLER      | ROULEAU DE GUIDAGE | RODILLO GUIA       |                           |     |
| 28       | 110 4633 | 22         | TELLERFEDER        | CUP SPRING        | RESSORT BELLEVILLE | RESORTE DE PLATO   | A 18 DIN 2093             |     |



SCHUTZSCHILD FÜR ZAPFWELLE  
 PTO MASTER SHIELD  
 DEFLECTEUR EMBOUT PRISE DE FORCE  
 PLACA PROTECTORA PARA ARBOL TOMA DE FUERZA

1001-63 500 6089

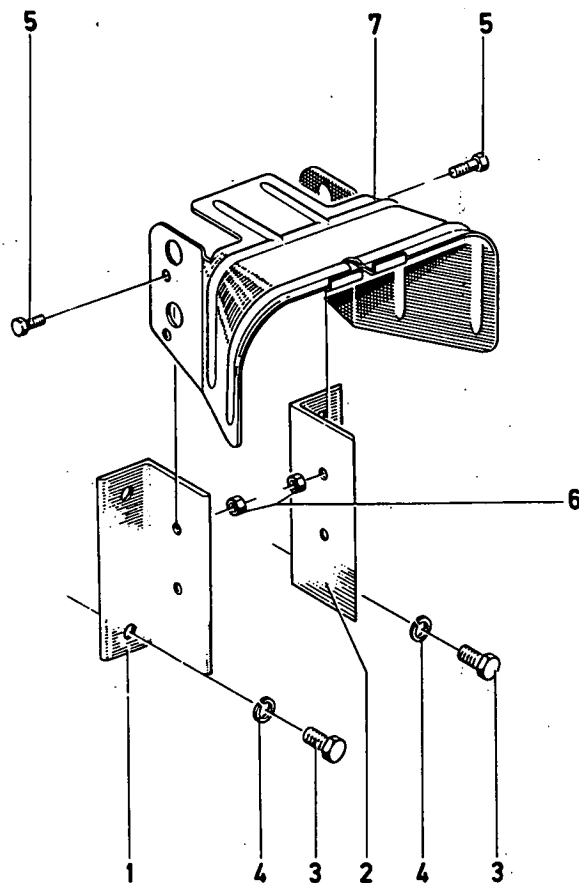

1001-63 500 6089

| Bild Nr. | Teile-Nr. | Stück-Zahl | Deutsch           | English           | Français           | Español            | Nummer/Bemerkung        | ETK |
|----------|-----------|------------|-------------------|-------------------|--------------------|--------------------|-------------------------|-----|
| 1        | 233 9916  | 1          | HALTER            | RETAINER          | SUPPORT/PORTEQUTIL | SOPORTE            | B195-LINCS              |     |
| 2        | 233 9920  | 1          | HALTER            | RETAINER          | SUPPORT/PORTEQUTIL | SOPORTE            | B267-RECHTS             |     |
| 3        | 111 2663  | 4          | SECHSKANTSCHRAUBE | HEX-BOLT          | VIS 6 PANS         | TORNILLO HEXAGONAL | M16X25 DIN 933-M8-8-A4C |     |
| 4        | 110 2803  | 4          | FEDERRING         | SPRING LOCKWASHER | RONDELLE GROMER    | ARANDELA ELASTICA  | A 16 DIN 126-A4C        |     |
| 5        | 111 2305  | 4          | SECHSKANTSCHRAUBE | HEX-BOLT          | VIS 6 PANS         | TORNILLO HEXAGONAL | M8X15 DIN 933-M8-8-A4C  |     |
| 6        | 111 2824  | 4          | SECHSKANTMUTTER   | HEX-NUT           | ECROU 6 PANS       | TUERCA HEXAGONAL   | M8 DIN 934-M8-A4C       |     |
| 7        | 233 9934  | 1          | MASTERSHIELD      | MASTERSHIELD      | PROTECTEUR PDF     | CUBIERTA PROTECC   |                         |     |

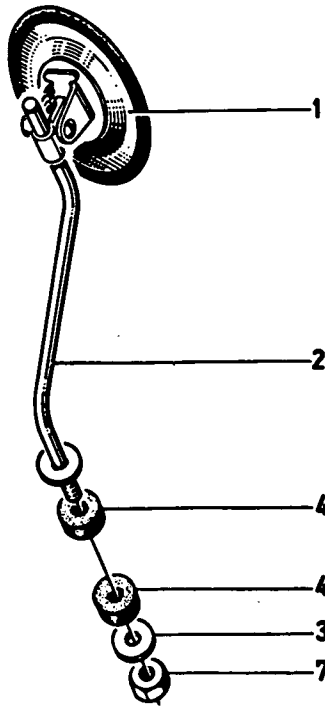

1110-67 500 3028

| Bild Nr. | Teile-Nr. | Stück-Zahl | Deutsch         | English         | Français            | Español          | Nummer/Bemerkung | ETK |
|----------|-----------|------------|-----------------|-----------------|---------------------|------------------|------------------|-----|
| 1        | 232 7346  | 1          | SPIEGEL         | MIRROR          | MIROIR/REFLECTEUR   | ESPEJO           |                  |     |
| 2        | 338 7583  | 1          | HALTER          | RETAINER        | SUPPORT/PORTE-OUTIL | SOPORTE          | 1110-67-04-10    |     |
| 3        | 338 7582  | 1          | SCHEIBE         | DISC/PANE/PLATE | RONDELLE/DISQUE     | DISCO            | 1110-67-03-03    |     |
| 4        | 121 8034  | 2          | GUMMIPUFFER     | RUBBER PAD      | TAMPON CAOUTCHOUC   | TOPE CAUCHO      | 7 565 C 5        |     |
| 7        | 112 6235  | 1          | SECHSKANTMUTTER | HEX-NUT         | ECROU 6 PANS        | TUERCA HEXAGONAL | M10 DIN 985-30   |     |



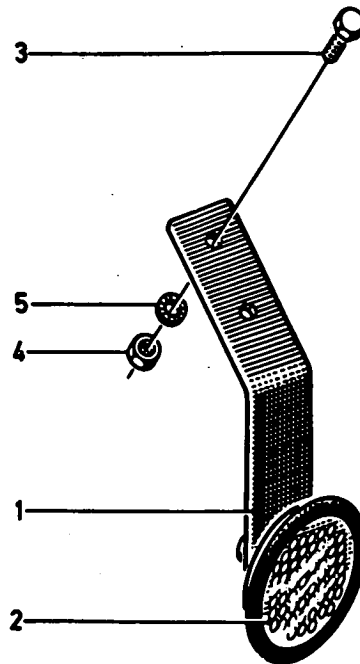

1005-68 500 3029

| Stk-Nr. | Teil-Nr. | Stück-Zahl | Deutsch           | English        | Français          | Español            | Nummer/Bemerkung         | ETK |
|---------|----------|------------|-------------------|----------------|-------------------|--------------------|--------------------------|-----|
| 1       | 230 6921 | 2          | HALTER            | RETAINER       | SUPPORT/PORTEQUIL | SOPORTE            |                          |     |
| 2       | 335 1864 | 2          | RUECKSTRAHLER     | REAR REFLECTOR | CATAPHOTE         | OJO DE GATO/REFLEC | GU80 H 7647              |     |
| 3       | 111 2251 | 4          | SECHSKANTSCHRAUBE | HEX.BOLT       | VIS 6 PANS        | TORNILLO HEXAGONAL | M 6x 15 DIN 933- 8-8-A4C |     |
| 4       | 111 2813 | 4          | SECHSKANTMUTTER   | HEX-NUT        | ECROU 6 PANS      | TUERCA HEXAGONAL   | M 6 DIN 934-M 8 A4C      |     |
| 5       | 116 7194 | 4          | SICHERUNGSSCHEIBE | LOCKING WASHER | RONDELLE SECURITE | ARANDELA SEGURIDAD | 6 H 2203                 |     |



RÜCKSTRAHLER - TRAGROHR  
 REAR REFLECTOR - CARRYING TUBE  
 CATADIOPTRE - TUBE PORTEUR  
 REFLECTORES TRASERO - TUBA DE OPOYO

1001-68 501 7137

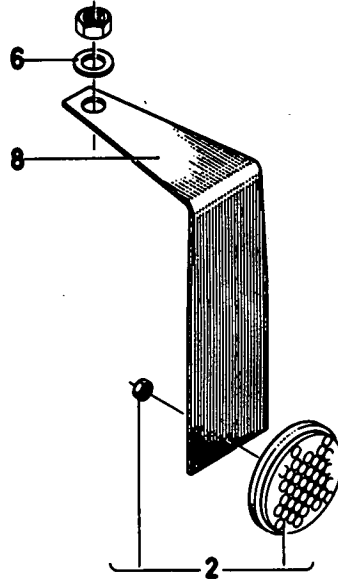
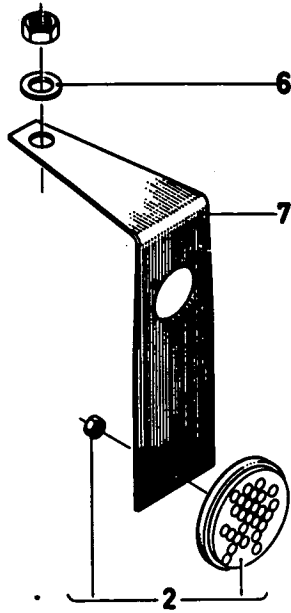

1001-68 501 7137

| Bild-Nr. | Teile-Nr. | Stück-Zahl | Deutsch       | English         | Français            | Español            | Nummer/Bemerkung        | ETK |
|----------|-----------|------------|---------------|-----------------|---------------------|--------------------|-------------------------|-----|
| 2        | 335 1864  | 2          | RUECKSTRAHLER | REAR REFLECTOR  | CATAPHOTE           | OJO DE GATO/REFLEC | 335 93 241              |     |
| 6        | 113 6317  | 4          | SCHEIBE       | DISC/PANE/PLATE | RONDILLE/DISQUE     | DISCO              | B13 DIN 9021 ST A4C     |     |
| 7        | 238 1955  | 2          | HALTER        | RETAINER        | SUPPORT/PORTE-OUTIL | SOPORTE            |                         |     |
| 8        | 238 1956  | 2          | HALTER        | RETAINER        | SUPPORT/PORTE-OUTIL | SOPORTE            | B003-AB FAHRGESTELL-N0- |     |



TANK INHALTSANZEIGE  
 FUEL GAUGE  
 JAUGE A COMBUSTIBLE  
 INDICACION PARA CONTENIDO DEL TANQUE

1001-69 500 4244

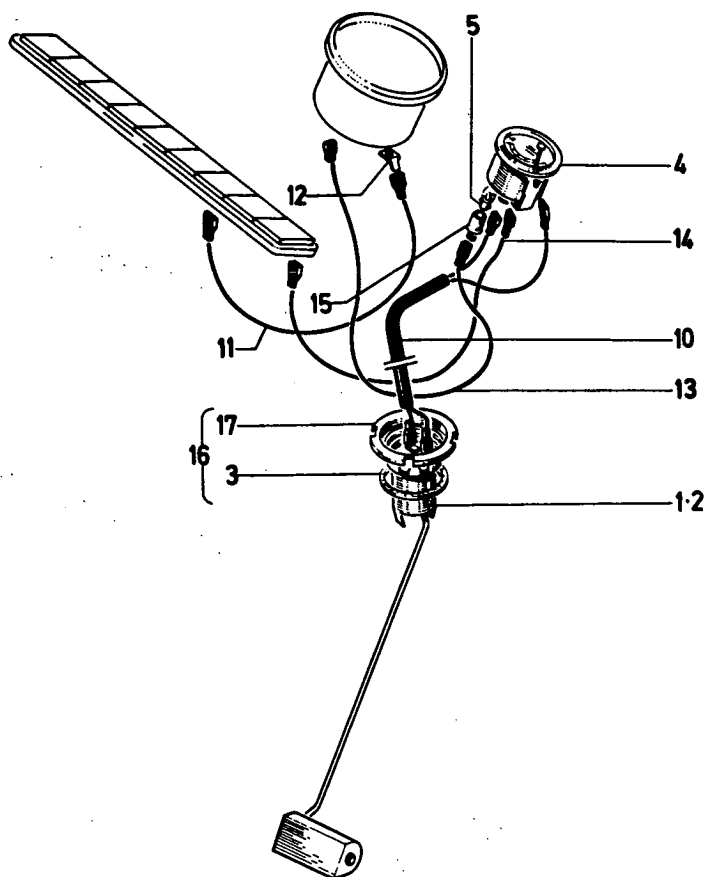

1001-69 500 4244

| Bild-Nr. | Teile-Nr. | Stück-Zahl | Deutsch       | English       | Français           | Español           | Nummer/Bemerkung     | ETK |
|----------|-----------|------------|---------------|---------------|--------------------|-------------------|----------------------|-----|
| 1        | 230 8168  | 1          | TANKGERAET    | LEVEL SENSOR  | DETECTEUR RES.     | DETECT-EN TANQUE  | 8355 WAHLWEISE POS.2 |     |
| 2        | 230 8169  | 1          | TANKGERAET    | LEVEL SENSOR  | DETECTEUR RES.     | DETECT-EN TANQUE  | 8355 WAHLWEISE POS.1 |     |
| 3        | 347 1085  | 1          | DICHRING      | WASHER        | BAGUE D ETANCHEITE | ANILLO DE JUNTA   | 1152-69-01.02        |     |
| 4        | 116 0348  | 1          | ANZEIGEGERAET | INDICATOR     | INDICATEUR         | APARTO-INDICACION | 860X24VFM 4234       |     |
| 5        | 112 1418  | 1          | GLUEHLAMPE    | LIGHT BULB    | LAMPE A INCANDESC  | BOMBILLA          | H 12V 2 W DIN72601   | 01  |
| 10       | 231 3884  | 1          | KABELSATZ     | SET OF WIRING | JEU DE CABLES      | LOTE CABLE        | 1152-69-01.02        |     |
| 11       | 233 1282  | 1          | LEITUNG       | LINE/LEAD     | CONDUCTEUR         | CONDUCTOR         | 1152-69-01.08        |     |
| 12       | 121 0566  | 1          | FLACHSTECKER  | FLAT PLUG     | FICHE PLATE        | ENCHUFE PLANO     | 7 602 B 1            |     |
| 13       | 237 2732  | 1          | LEITUNG       | LINE/LEAD     | CONDUCTEUR         | CONDUCTOR         |                      |     |
| 14       | 237 4927  | 1          | LEITUNG       | LINE/LEAD     | CONDUCTEUR         | CONDUCTOR         |                      |     |
| 15       | 121 4679  | 1          | LAMPENFASSUNG | LAMP SOCKET   | DOUILLE D AMPOULE  | PORTALAMPARA      | 7 645 B 2 IN KLAMMER |     |
| 16       | 232 6090  | 1          | VERSCHLUSS    | FASTENER/LOCK | FERMETURE          | CIERRE            |                      |     |
| 17       | 347 5079  | 1          | DECKEL        | COVER         | COUVERCLE          | TAPA              |                      |     |

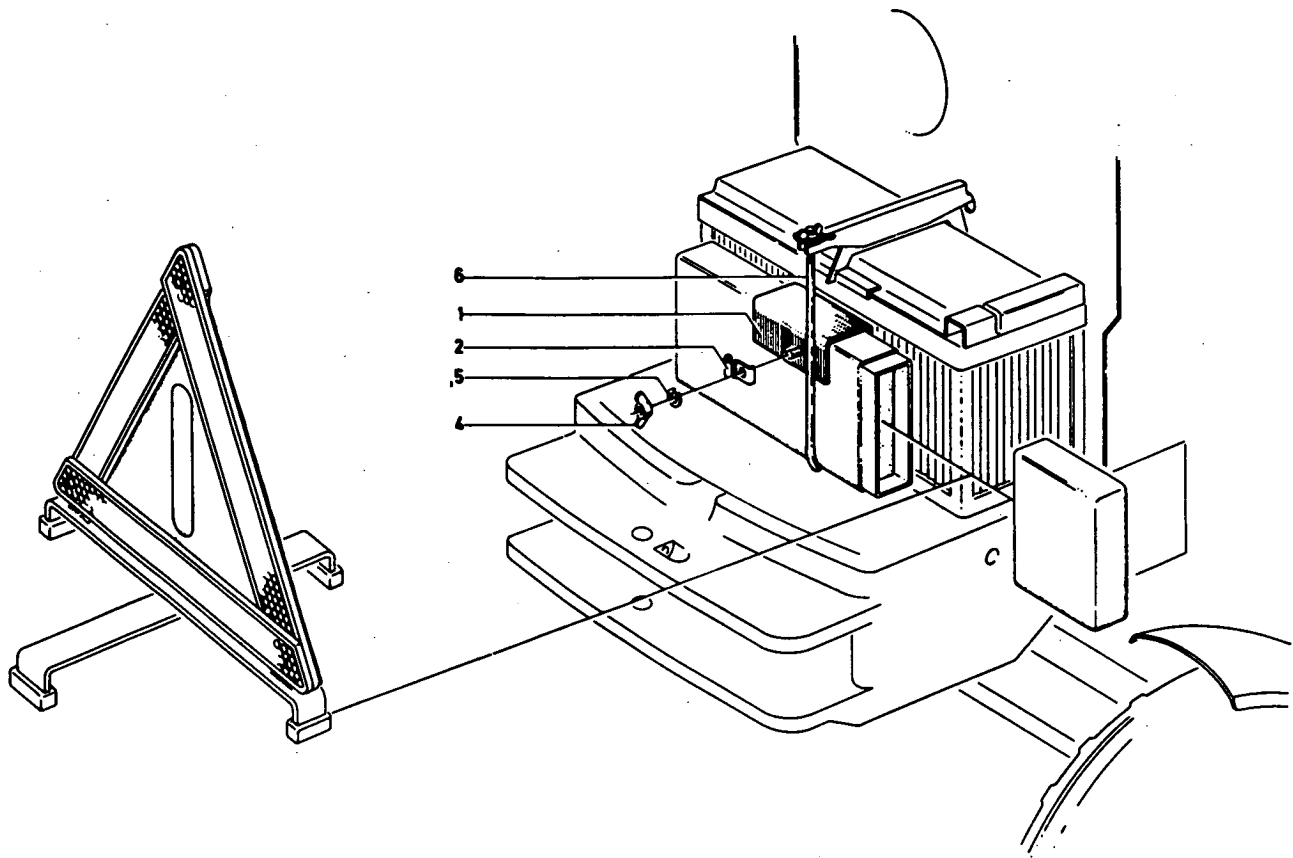

1001-70 500 3031

| Bild Nr. | Teile-Nr. | Stück-Zahl | Deutsch       | English           | Français           | Español            | Numer/Bemerkung          | ETK |
|----------|-----------|------------|---------------|-------------------|--------------------|--------------------|--------------------------|-----|
| 1        | 232 7271  | 1          | HALTER        | RETAINER          | SUPPORT/PORTE-UTIL | SOPORTE            |                          |     |
| 2        | 111 5943  | 1          | ROHRSCHELLE   | PIPE CLIP         | COLLIER PR TUBES   | ABRAZADERA DE TUBO | 9 DIN 1592               |     |
| 4        | 110 7356  | 1          | FLUEGELMUTTER | WING NUT          | ECROU A AILETTES   | TUERCA MARIPOSA    | M 6 DIN 315-6 GTW35 VZKC |     |
| 5        | 110 2797  | 1          | FEDERRING     | SPRING LOCKWASHER | RONDELLE GROWER    | ARANDELA ELASTICA  | A 6 DIN 328 A4C          |     |
| 6        | 232 7268  | 1          | HAKENSCHRAUBE | HOOK SCREW        | VIS A CROCHET      | TORNILLO CANCAMO   |                          |     |



**SCHILDER  
MARKING PLATES  
PLAQUES  
ROTULOS**

7876/6679  
7868/0403

1001-71 502 0151

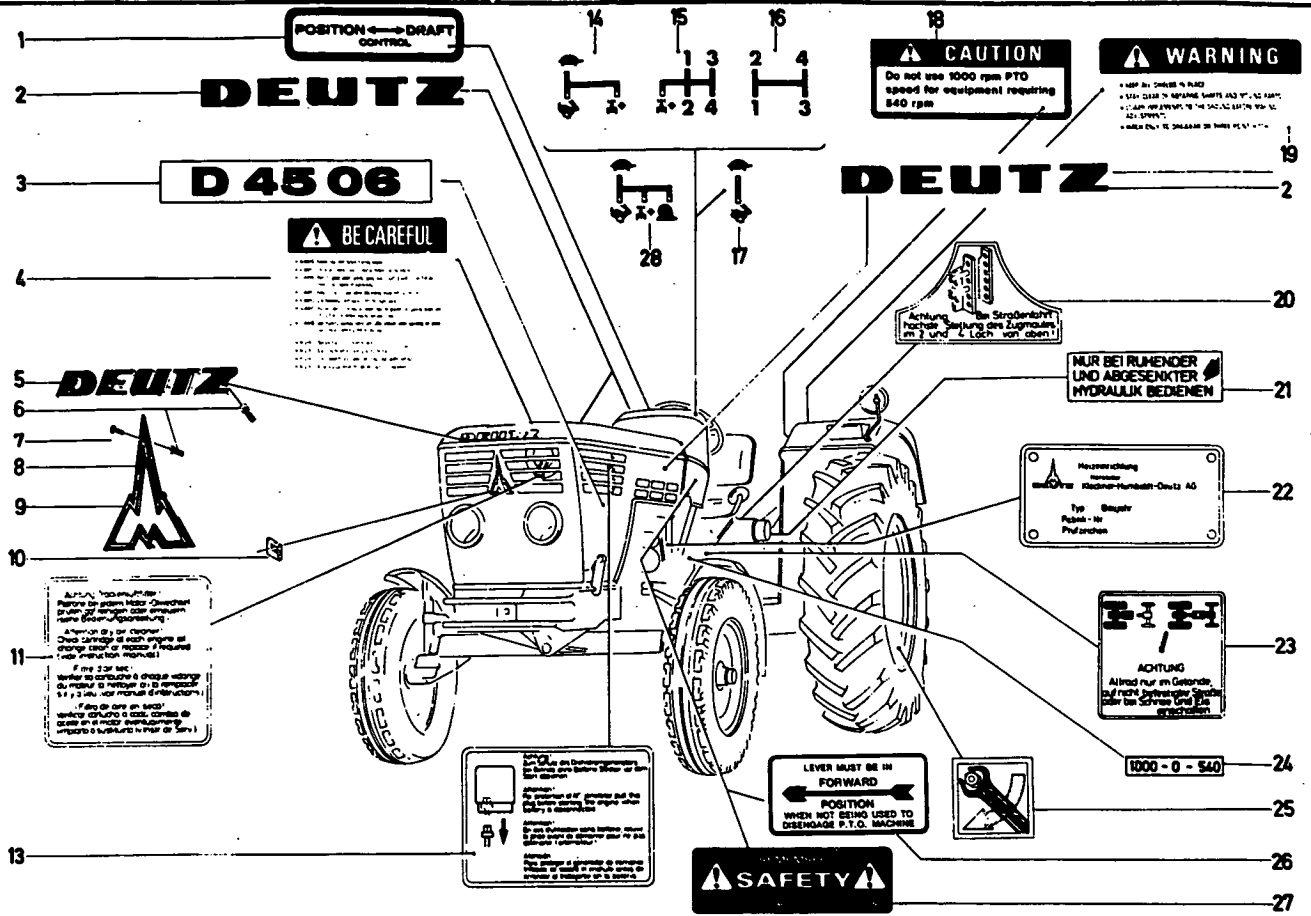

1001-71 502 0151

| Bild Nr. | Teile-Nr. | Stück-Zahl | Deutsch          | English           | Français           | Español           | Nummer/Bemerkung                             | ETK                |
|----------|-----------|------------|------------------|-------------------|--------------------|-------------------|--|--------------------|
| 1        | 238 1210  | 1          | BEDIENUNGSSCHILD | INSTRUCTION PLATE | PLAQUE INSTRUCTNS  | ROTULO SERVICIO   | USA-   |                    |
| 2        | 121 3748  | 3          | PRODUKTSCHILD    | PRODUCT PLATE     | PLAQUE PRODUIT     | ROTULO PRODUCTO   | 4 323 A 5                                    |                    |
| 3        | 121 4737  | 2          | TYPSCCHILD       | NAME PLATE        | PLAQUE DE TYPE     | ROTULO TIPO       |  |                    |
| 4        | 238 1212  | 1          | WARNSCHILD       | WARNING PLATE     | PANNEAU AVERTISS-  | ROTULO AVISO      | USA-   |                    |
| 5        | 121 4950  | 1          | FIRMENSCHILD     | NAMEPLATE/NAME    | PLAQUE DE FIRME    | ROTULO FABRICA    | 4 303 A 300                                  |                    |
| 6        | 121 0674  | 14         | TUELLE           | GROMMET           | DOUILLE            | FUNDA             | 7 565 M 1                                    |                    |
| 7        | 121 1000  | 4          | HALBRUNDNIEZ     | ROUND-HEAD RIVET  | RIVET A TETE DEMIR | REMACHE SEMIRRED- | 187 275 M 1                                  |                    |
| 8        | 121 4952  | 1          | FIRMENZEICHEN    | TRADE MARK        | EMBLEME DE FIRME   | EMBLEMA MARCA     | 4 315 A 10<br>8046, 3E1 SCHEINWERFER AUSSEN- |                    |
| 9        | 121 4951  | 1          | FIRMENZEICHEN    | TRADE MARK        | EMBLEME DE FIRME   | EMBLEMA MARCA     | 4 315 A 9                                    | IN KLAMMER schwarz |
| 10       | 116 7204  | 3          | SICHERUNGSBLECH  | LOCKING PLATE     | TOLE DE SECURITE   | CHAPA SEGURIDAD   | A2.5 1 2219                                  |                    |
| 11       | 121 1590  | 1          | BEDIENUNGSSCHILD | INSTRUCTION PLATE | PLAQUE INSTRUCTNS  | ROTULO SERVICIO   |  |                    |
| 13       | 121 2263  | 1          | AUFSCHRIFTSCHILD | MARKING PLATE     | PLAQUE D INSCRIPT- | ROTULO            |  |                    |
| 14       | 121 4999  | 1          | SINNBILD         | SYMBOL            | EMBLEME            | SIMBOLO MARCA     |  |                    |
| 15       | 121 4996  | 1          | SINNBILD         | SYMBOL            | EMBLEME            | SIMBOLO MARCA     |  |                    |
| 16       | 121 4998  | 1          | SINNBILD         | SYMBOL            | EMBLEME            | SIMBOLO MARCA     |  |                    |
| 17       | 121 4995  | 1          | SINNBILD         | SYMBOL            | EMBLEME            | SIMBOLO MARCA     |  |                    |
| 18       | 238 1215  | 1          | WARNSCHILD       | WARNING PLATE     | PANNEAU AVERTISS-  | ROTULO AVISO      | USA-   |                    |
| 19       | 238 1214  | 1          | WARNSCHILD       | WARNING PLATE     | PANNEAU AVERTISS-  | ROTULO AVISO      | USA-   |                    |
| 20       | 121 0091  | 1          | AUFSCHRIFTSCHILD | MARKING PLATE     | PLAQUE D INSCRIPT- | ROTULO            |  |                    |
| 21       | 121 0622  | 1          | HINWEISSCHILD    | MARKING PLATE     | PLAQUE INDICATRICE | ROTULO INDICADOR  | 8062, DEUTSCH<br>8285, SIEHE POS. 950-954    |                    |
| 22       | 121 3712  | 1          | FIRMENSCHILD     | NAMEPLATE/NAME    | PLAQUE DE FIRME    | ROTULO FABRICA    |  |                    |
| 23       | 231 5752  | 1          | BEDIENUNGSSCHILD | INSTRUCTION PLATE | PLAQUE INSTRUCTNS  | ROTULO SERVICIO   | 8062, DEUTSCH<br>8285, SIEHE POS. 955-957    |                    |

| Bd Nr | Teil-Nr. | Stück-Zahl | Deutsch          | English           | Français           | Español            | Nummer/Bemerkung  | ETK |
|-------|----------|------------|------------------|-------------------|--------------------|--------------------|-------------------|-----|
| 24    | 231 0956 | 1          | SCHALTBILD       | SHIFTING GRAPHIC  | SCHEMA CONNEXIONS  | ESQUEMA CONEXIONES |                   |     |
| 25    | 121 7068 | 1          | BEDIENUNGSSCHILD | INSTRUCTION PLATE | PLAQUE INSTRUCTNS  | ROTULO SERVICIO    | 4 303 A 406       |     |
| 26    | 238 1211 | 1          | BEDIENUNGSSCHILD | INSTRUCTION PLATE | PLAQUE INSTRUCTNS  | ROTULO SERVICIO    | USA-              |     |
| 27    | 238 1213 | 1          | WARNSCHILD       | WARNING PLATE     | PANNEAU AVERTISS.  | ROTULO AVISO       | USA-              |     |
| 28    | 121 4997 | 1          | SINNBILD         | SYMBOL            | EMBLEME            | SIMBOLO MARCA      |                   |     |
| 950   | 121 0647 | NB         | HINWEISSCHILD    | MARKING PLATE     | PLAQUE INDICATRICE | ROTULO INDICADOR   | B071-ENGLISCH     |     |
| 951   | 121 0644 | NB         | HINWEISSCHILD    | MARKING PLATE     | PLAQUE INDICATRICE | ROTULO INDICADOR   | B080-FRANZOESISCH |     |
| 952   | 121 0646 | NB         | HINWEISSCHILD    | MARKING PLATE     | PLAQUE INDICATRICE | ROTULO INDICADOR   | B298-SPANISCH     |     |
| 953   | 121 0645 | NB         | HINWEISSCHILD    | MARKING PLATE     | PLAQUE INDICATRICE | ROTULO INDICADOR   | B163-ITALIENISCH  |     |
| 954   | 121 0643 | NB         | HINWEISSCHILD    | MARKING PLATE     | PLAQUE INDICATRICE | ROTULO INDICADOR   | B153-40LLAENDISCH |     |
| 955   | 231 9546 | NB         | BEDIENUNGSSCHILD | INSTRUCTION PLATE | PLAQUE INSTRUCTNS  | ROTULO SERVICIO    | B071-ENS..ISCH    |     |
| 956   | 231 9547 | NB         | BEDIENUNGSSCHILD | INSTRUCTION PLATE | PLAQUE INSTRUCTNS  | ROTULO SERVICIO    | B080-FRANZOESISCH |     |
| 957   | 231 9548 | NB         | BEDIENUNGSSCHILD | INSTRUCTION PLATE | PLAQUE INSTRUCTNS  | ROTULO SERVICIO    | B298-SPANISCH     |     |



SCHILDER  
MARKING PLATES  
PLAQUES  
ROTULOS

7876/6678  
7868/0402

1004-71 5004246

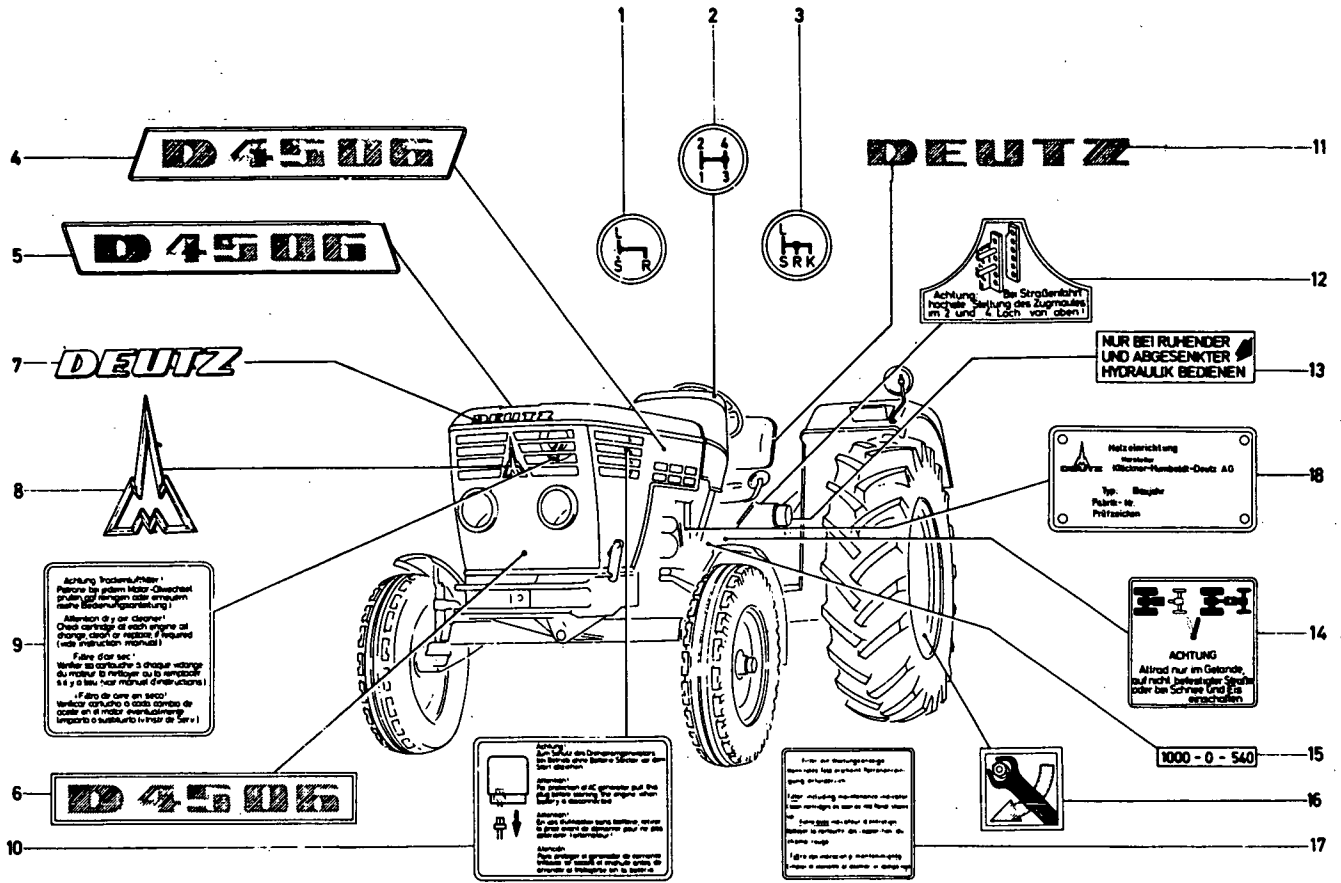

1004-71 500 4246

| Bild Nr. | Teile-Nr. | Stück-Zahl | Deutsch          | English           | Français           | Español            | Nummer/Bemerkung                                       | ETH |
|----------|-----------|------------|------------------|-------------------|--------------------|--------------------|--|-----|
| 1        | 230 3502  | 1          | SCHALTBILD       | SHIFTING GRAPHIC  | SCHEMA CONNEXIONS  | ESQUEMA CONEXIONES |  |     |
| 2        | 230 3501  | 1          | SCHALTBILD       | SHIFTING GRAPHIC  | SCHEMA CONNEXIONS  | ESQUEMA CONEXIONES |  |     |
| 3        | 231 1601  | 1          | SCHALTBILD       | SHIFTING GRAPHIC  | SCHEMA CONNEXIONS  | ESQUEMA CONEXIONES |  |     |
| 4        | 121 2996  | 1          | TYPSCCHILD       | NAME PLATE        | PLAQUE DE TYPE     | ROTULO TIPO        | 4 304 A 78 IN KLAMMER                                  |     |
| 5        | 121 2995  | 1          | TYPSCCHILD       | NAME PLATE        | PLAQUE DE TYPE     | ROTULO TIPO        | 4 304 A 77 IN KLAMMER                                  |     |
| 6        | 121 2994  | 1          | TYPSCCHILD       | NAME PLATE        | PLAQUE DE TYPE     | ROTULO TIPO        | 4 304 A 76 IN KLAMMER                                  |     |
| 7        | 121 0675  | 1          | FIRMENSCHILD     | NAMEPLATE/NAME    | PLAQUE DE FIRME    | ROTULO FABRICA     | 4 303 A 182  |     |
| 8        | 121 8017  | 1          | FIRMENZEICHEN    | TRADE MARK        | EMBLEME DE FIRME   | EMBLEMA MARCA      | 4 315 A gold-farben                                    |     |
| 9        | 121 1590  | 1          | BEDIENUNGSSCHILD | INSTRUCTION PLATE | PLAQUE INSTRUCTNS  | ROTULO SERVICIO    | 4 308 A 656  |     |
| 10       | 121 2263  | 1          | AUFCHRIFTSCHILD  | MARKING PLATE     | PLAQUE D INSCRIPT. | ROTULO             | 4 311 A 980 IN KLAMMER                                 |     |
| 11       | 121 0752  | 1          | FIRMENSCHILD     | NAMEPLATE/NAME    | PLAQUE DE FIRME    | ROTULO FABRICA     | 4 303 A 186  |     |
| 12       | 121 0091  | 1          | AUFCHRIFTSCHILD  | MARKING PLATE     | PLAQUE D INSCRIPT. | ROTULO             | 4 311 A 886  |     |
| 13       | 121 0622  | 1          | HINWEISSCHILD    | MARKING PLATE     | PLAQUE INDICATRICE | ROTULO INDICADOR   | 4 308 A 634<br>8062-DEUTSCH<br>8285-SIEHE POS. 950-954 |     |
| 14       | 231 5752  | 1          | BEDIENUNGSSCHILD | INSTRUCTION PLATE | PLAQUE INSTRUCTNS  | ROTULO SERVICIO    | 8062-DEUTSCH<br>8285-SIEHE POS. 955-957                |     |
| 15       | 231 0959  | 1          | SCHALTBILD       | SHIFTING GRAPHIC  | SCHEMA CONNEXIONS  | ESQUEMA CONEXIONES |  |     |
| 16       | 121 7068  | 1          | BEDIENUNGSSCHILD | INSTRUCTION PLATE | PLAQUE INSTRUCTNS  | ROTULO SERVICIO    | 4 308 A 406  |     |
| 17       | 121 1650  | 1          | AUFCHRIFTSCHILD  | MARKING PLATE     | PLAQUE D INSCRIPT. | ROTULO             | 4 311 A 969 IN KLAMMER                                 |     |
| 18       | 121 3712  | 1          | FIRMENSCHILD     | NAMEPLATE/NAME    | PLAQUE DE FIRME    | ROTULO FABRICA     | 4 303 A 246 IN KLAMMER                                 |     |
| 950      | 121 0647  | NB         | HINWEISSCHILD    | MARKING PLATE     | PLAQUE INDICATRICE | ROTULO INDICADOR   | 4 308 B 634<br>8071-ENGLISCH                           |     |
| 951      | 121 0644  | NB         | HINWEISSCHILD    | MARKING PLATE     | PLAQUE INDICATRICE | ROTULO INDICADOR   | 4 308 C 634<br>8080-FRANZOESISCH                       |     |
| 952      | 121 0646  | NB         | HINWEISSCHILD    | MARKING PLATE     | PLAQUE INDICATRICE | ROTULO INDICADOR   | 4 308 D 634<br>8298-SPANISCH                           |     |

| Bild<br>Nr. | Teile-Nr. | Stück-<br>Zahl | Deutsch          | English           | Français           | Español          | Nummer/Bemerkung                 | ETK |
|-------------|-----------|----------------|------------------|-------------------|--------------------|------------------|----------------------------------|-----|
| 953         | 121 0645  | NB             | HINWEISSCHILD    | MARKING PLATE     | PLAQUE INDICATRICE | ROTULO INDICADOR | 4 308 J 634<br>8163-ITALIENISCH  |     |
| 954         | 121 0643  | NB             | HINWEISSCHILD    | MARKING PLATE     | PLAQUE INDICATRICE | ROTULO INDICADOR | 4 308 F 634<br>8153-HOLLAENDISCH |     |
| 955         | 231 9546  | NB             | BEDIENUNGSSCHILD | INSTRUCTION PLATE | PLAQUE INSTRUCTNS  | ROTULO SERVICIO  | 8071-ENGLISCH                    |     |
| 956         | 231 9547  | NB             | BEDIENUNGSSCHILD | INSTRUCTION PLATE | PLAQUE INSTRUCTNS  | ROTULO SERVICIO  | 8080-FRANZOESISCH                |     |
| 957         | 231 9548  | NB             | BEDIENUNGSSCHILD | INSTRUCTION PLATE | PLAQUE INSTRUCTNS  | ROTULO SERVICIO  | 8298-SPANISCH                    |     |



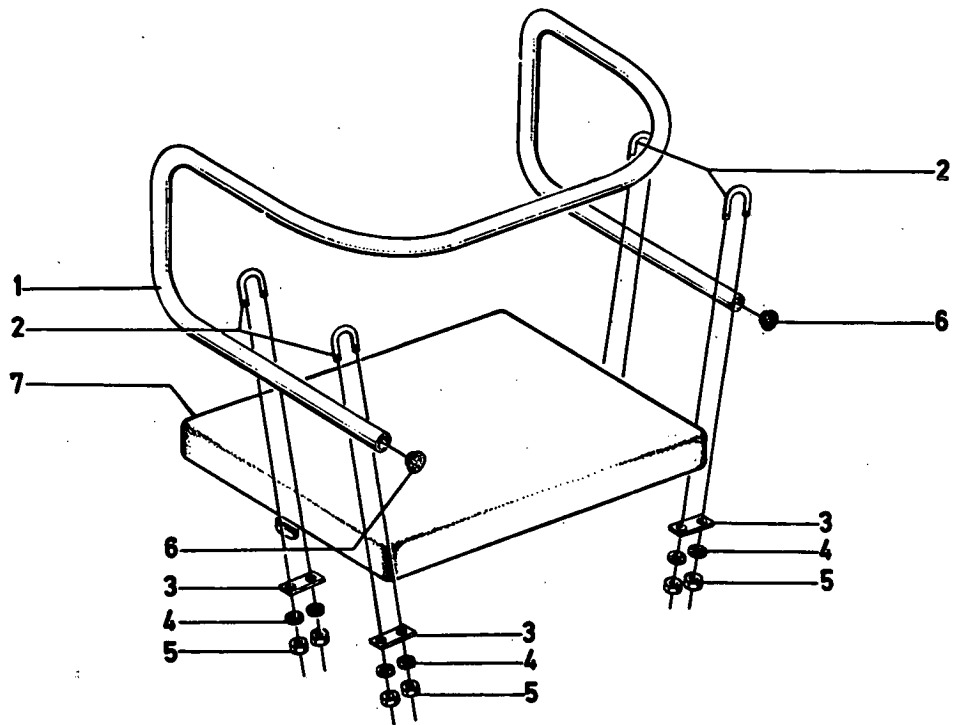

1001-76 500 3033

| Bld. Nr. | Teile-Nr. | Stück-Zahl | Deutsch            | English          | Français           | Español                  | Nummer/Bemerkung    | ETK |
|----------|-----------|------------|--------------------|------------------|--------------------|--------------------------|---------------------|-----|
| 1        | 230 6322  | 1          | RUECKLEHNE         | BACKREST         | DOSSIER            | RESPALDO DE ASIENTO      |                     |     |
| 2        | 338 7158  | 4          | BUEGELSCHRAUBE     | U-BOLT           | VIS/BOULON EN U    | TORNILLO ASA             | 1055-51-01-06       |     |
| 3        | 338 7157  | 4          | VERSTAERKGS-PLATTE | STIFFENING PLATE | PLAQUE RENFORT     | PLACA REFUERZO           | 1055-51-01-05       |     |
| 4        | 116 7194  | 8          | SICHERUNGSSCHEIBE  | LOCKING WASHER   | RONDELLE SECURITE  | ARANDELA SEGURIDAD       | 6 M 2203            |     |
| 5        | 111 2813  | 8          | SECHSKANTMUTTER    | HEX-NUT          | ECROU 6 PANS       | TUERCA HEXAGONAL         | M 6 DIN 934-M 8 A4C |     |
| 6        | 230 6798  | 2          | VERSCHLUSSSTOPFEN  | NIPPLE           | BOUCHON            | TAPON OBTURADOR          |                     |     |
| 7        | 238 2803  | 1          | SITZPOLSTER        | SEAT PAD         | REMBOURRAGE        | TAPIZADO ASIENTO         |                     |     |
| 8        | 230 6792  | 1          | BEIFAHRERSITZ      | PASSENGER SEAT   | SIEGE DE CONVOYEUR | ASIENTO PARA ACOMPAÑANTE | B247, OBRG POS. 7   |     |



ZAPFWELLE  
STANDARD PTO SHAFT  
PRISE DE FORCE  
ARBOL TOMA DE FUERZA

1435-77 500 4248

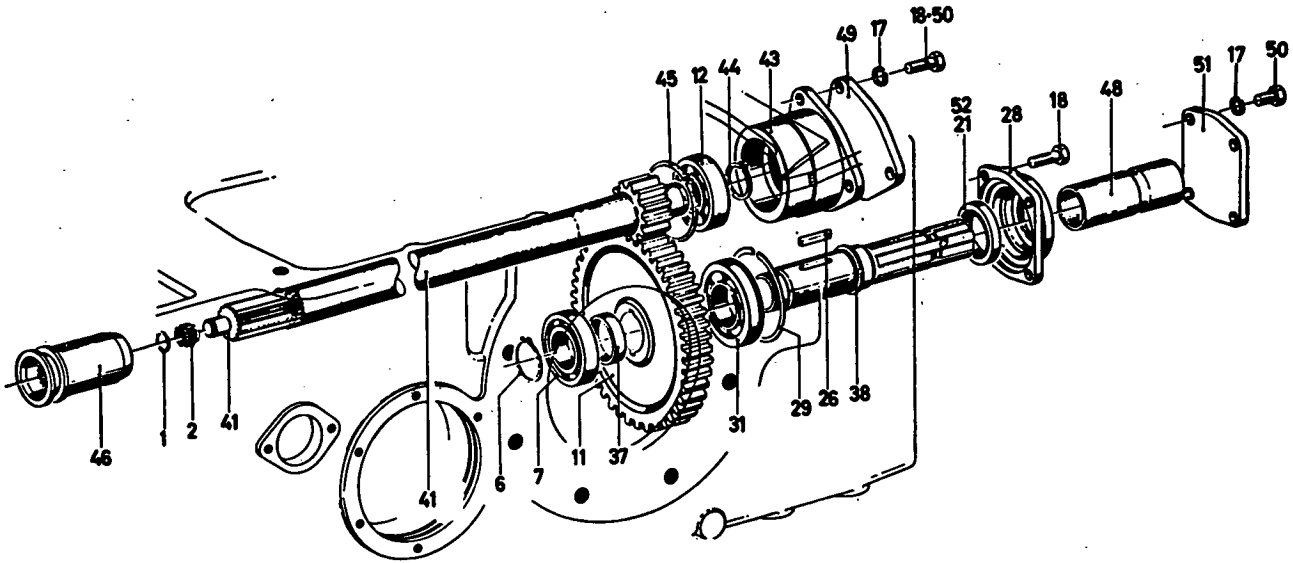

1435-77 500 4248

| Bild Nr. | Teile-Nr. | Stück-Zahl | Deutsch           | English           | Français           | Español            | Nummer/Bemerkung  | ETK |
|----------|-----------|------------|-------------------|-------------------|--------------------|--------------------|---|-----|
| 1        | 116 7214  | 1          | SPRENGRING        | SNAP RING         | AGRAFE CIRCULAIRE  | ANILLO RETENCION   | 10X1 H 225A   |     |
| 2        | 116 8715  | 1          | NADELKAEFIG       | NEEDLE GAGE       | CAGE A AIGUILLES   | JAULA AGUJAS       | H8 10 X 13X13 H 4455  | 01  |
| 6        | 110 7742  | 1          | SICHERUNGSRING    | CIRCLIP           | CIRCLIP            | CIRCLIP            | 30X1,5 DIN 471  |     |
| 7        | 110 9050  | 1          | RILLENKUGELLAGER  | BALL BEARING      | ROUL RAINURE BILLE | COJ-BOLAS FIJO     | 6206 DIN 625  | 01  |
| 11       | 339 2153  | 1          | ZAHNRAD           | GEAR              | ROUE DENTEE        | RUEDA DENTADA      | 1424-77-01-27<br>Z 46   |     |
| 12       | 111 7066  | 1          | ZYL.-ROLLENLAGER  | PAR.ROLL-BEARING  | ROULEM-ROUL-CYL-   | COJ-RODILL-CILINDR | NJ 207 DIN 5412   | 01  |
| 17       | 110 2799  | 3          | FEBERRING         | SPRING LOCKWASHER | ROVDELLE GROWER    | ARANDELA ELASTICA  | A 8 DIN 128 A4C   |     |
| 18       | 111 2320  | 7          | SECHSKANTSCHRAUBE | HEX.BOLT          | VIS 6 PANS         | TORNILLO HEXAGONAL | M 8X 20 DIN 933- 8-8  |     |
| 21       | 116 7498  | 1          | WELLENDICHTRING   | SHAFT SEAL        | JOINT D ARBRE      | ANILLO HERMET-EJE  | A 35X 47 X 7 H 2940-NI<br>8027-BIS FAHRGESTELL-NO<br>7876/8054-7868/0479<br>8004-AB FAHRGESTELL-NO POS-52 | 01  |
| 26       | 111 8083  | 2          | PASSFEDER         | KEY               | CLAVETTE ENCASTREE | LENGUETA AJUSTE    | A10X 8X 56 DIN 6885   |     |
| 28       | 238 4203  | 1          | LAGERDECKEL       | BEARING CAP       | CHAPEAU DE PALIER  | TAPA SOPORTE       | 8042-BEI ERSTMALIGEM ERSATZ<br>BIS FAHRGESTELL-NO<br>7876/8054-7868/0479<br>POS-38+52 MITLIEFERN          |     |
| 29       | 111 7455  | 1          | SPRENGRING        | SNAP RING         | AGRAFE CIRCULAIRE  | ANILLO RETENCION   | SP 72DIN 5417   |     |
| 31       | 110 9059  | 1          | RILLENKUGELLAGER  | BALL BEARING      | ROUL RAINURE BILLE | COJ-BOLAS FIJO     | 6207 N DIN 625  | 01  |
| 37       | 230 7567  | 1          | ABSTANDROHR       | SPACER TUBE       | TUBE ECARTEMENT    | TUBO DISTANCIARIO  |   |     |
| 38       | 238 4204  | 1          | ZAPFWELLE         | PTO SHAFT         | ARBRE P.-D.-F.     | ARBOL TOMA FUERZA  | 8042-BEI ERSTMALIGEM ERSATZ<br>BIS FAHRGESTELL-NO<br>7876/8054-7868/0479<br>POS-28+52 MITLIEFERN          |     |
| 41       | 231 1294  | 1          | ANTRIEBSWELLE     | DRIVE SHAFT       | ARBRE DE COMMANDE  | EJE MOTRIZ         | Z 12  |     |
| 43       | 231 1292  | 1          | LAGERDECKEL       | BEARING CAP       | CHAPEAU DE PALIER  | TAPA SOPORTE       |   |     |
| 44       | 110 7748  | 1          | SICHERUNGSRING    | CIRCLIP           | CIRCLIP            | CIRCLIP            | 35X1,5 DIN 471  |     |
| 45       | 116 9740  | 1          | SICHERUNGSRING    | CIRCLIP           | CIRCLIP            | CIRCLIP            | 72H 2272  |     |

| Bild<br>Nr. | Teil-Nr. | Stück-<br>Zahl | Deutsch           | English      | Français          | Español                                      | Nummer/Bemerkung | ETK |
|-------------|----------|----------------|-------------------|--------------|-------------------|--|------------------|-----|
| 46          | 233 3803 | 1              | SCHALTRUFFE       | SHIFT SLEEVE | MANCHON COMMANDE  | MANGUITO CAMBIO                              |                  |     |
| 48          | 232 9248 | 1              | ZAPFWELLENSCHUTZ  | PTO GUARD    | GARDE PRISE FORCE | PROTEC-TOMAFUERZA                            |                  |     |
| 49          | 230 7582 | 1              | DECKEL            | COVER        | COUVERCLE         | TAPA   |                  |     |
| 50          | 111 2305 | 7              | SECHSKANTSCHRAUBE | HEX-BOLT     | VIS 6 PANS        | TORNILLO HEXAGONAL M 8 X 15 DIN 933- 8.8-A4C |                  |     |
| 51          | 232 1504 | 1              | DECKEL            | COVER        | COUVERCLE         | TAPA   |                  |     |
| 52          | 117 2223 | 1              | WELLENDICHTRING   | SHAFT SEAL   | JOINT D ARBRE     | ANILLO HERMET-EJE S 38X 52 X 7 H 2940-NI     |                  | 01  |



**DUO-ZAPFWELLE**  
**TWO-SPEED PTO SHAFT**  
**PRISE DE FORCE PERMETTANT D'OBTENIR 2 REGIMES DE ROTATION**  
**ARBOL TOMA DE FUERZA TIPO DUO**

1446-77 500 4249

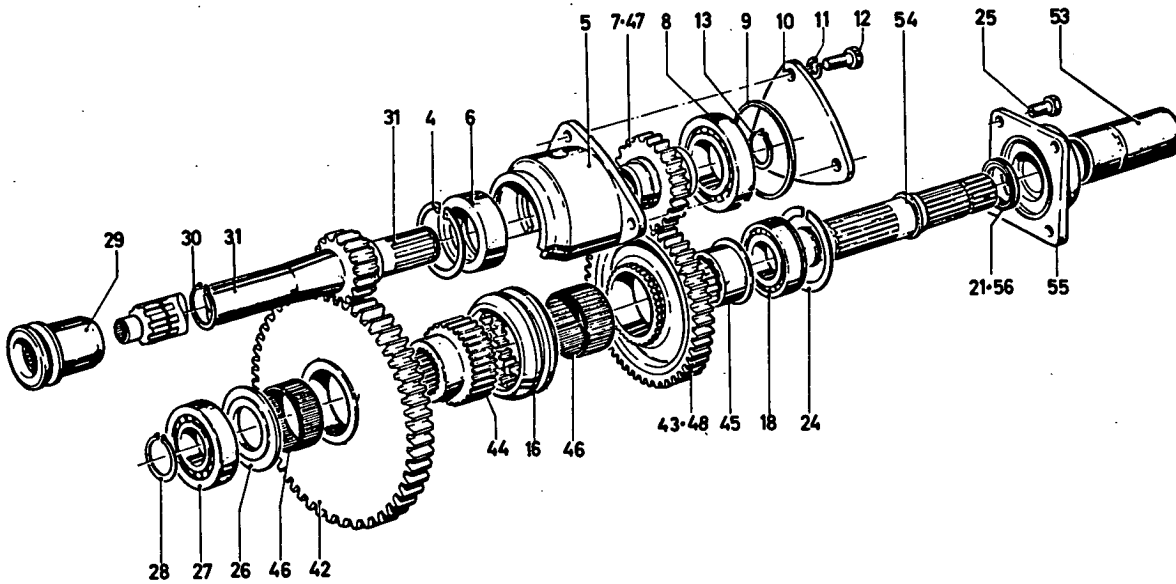

1446-77 500 4249

| Bld. Nr. | Teile-Nr. | Stück-Zahl | Deutsch           | Englsh            | Français           | Español             | Nummer/Bemerkung  | ETK |
|----------|-----------|------------|-------------------|-------------------|--------------------|---------------------|---|-----|
| 4        | 110 7636  | 1          | SICHERUNGSRING    | CIRCLIP           | CIRCLIP            | CIRCLIP             | 52X2 DIN 472  |     |
| 5        | 230 7576  | 1          | LAGERDECKEL       | BEARING CAP       | CHAPEAU DE PALIER  | TAPA SOPORTE        |   |     |
| 6        | 112 5674  | 1          | AUSSENRING        | OUTER RACE        | BAGUE EXTERIEURE   | ARO EXTERIOR        | RNU 2205E DIN 5412  | 01  |
| 7        | 230 7560  | 1          | ZAHNRAD           | GEAR              | ROUE DENTEE        | RUEDA DENTADA       | Z 19<br>8027-916 FAHRGESTELL-NO<br>8004-AB FAHRGESTELL-NO POS-47  |     |
| 8        | 110 9057  | 1          | WILLENKUGELLAGER  | BALL BEARING      | ROUL RAINURE BILLE | COJ-BOLAS FIJO      | 6207 DIN 625  | 01  |
| 9        | 230 1711  | SZ         | BEILAGE           | SHIM              | CALE               | SUPLEMENTO          | 8076-EINZELTEILE SIEME POS-<br>950-955  |     |
| 10       | 230 7582  | 1          | DECKEL            | COVER             | COUVERCLE          | TAPA                |   |     |
| 11       | 110 2799  | 3          | FEDERRING         | SPRING LOCKWASHER | RONDILLE GROUER    | ARANDELA ELASTICA   | A 8 DIN 128 A4C   |     |
| 12       | 111 2331  | 3          | SECHSKANTSCHRAUBE | HEX-BOLT          | VIS 6 PANS         | TORNILLO HEXAGONAL  | M 8X 25 DIN 933- 8-8  |     |
| 13       | 110 2356  | 1          | SICHERUNGSRING    | CIRCLIP           | CIRCLIP            | CIRCLIP             | 20X1,2 DIN 983  |     |
| 14       | 230 7589  | 1          | SCHALTRUFFE       | SHIFT SLEEVE      | MANCHON COMMANDE   | MANGUITO CAMBIO     |   |     |
| 18       | 110 9059  | 1          | WILLENKUGELLAGER  | BALL BEARING      | ROUL RAINURE BILLE | COJ-BOLAS FIJO      | 6207 V DIN 625  | 01  |
| 21       | 116 7498  | 1          | WELLENDICHTRING   | SHAFT SEAL        | JOINT D ARBRE      | ANILLO HERMET-EJE   | A 35X 47 X 7 H 2940-NI<br>8027-316 FAHRGESTELL-NO<br>7876/8054 7868/0479<br>8004-AB FAHRGESTELL-NO-POS-56 | 01  |
| 24       | 111 7455  | 1          | SPRENGRING        | SNAP RING         | AGRAFE CIRCULAIRE  | ANILLO RETENCION    | SP 72014 5417   |     |
| 25       | 111 2320  | 4          | SECHSKANTSCHRAUBE | HEX-BOLT          | VIS 6 PANS         | TORNILLO HEXAGONAL  | M 8X 20 DIN 933- 8-8  |     |
| 26       | 230 7592  | 1          | ANLAUFSCHWEIBE    | STOP WASHER       | DISQUE BUTEE       | ARANDELA TOPE       |   |     |
| 27       | 111 7286  | 1          | ZYL.-ROLLENLAGER  | PAR-ROLL-BEARING  | ROULEM-ROUL-CYL.   | COJ-RODILL-CILINDR. | NUP 206 DIN 5412  | 01  |
| 28       | 121 8425  | 1          | SICHERUNGSRING    | CIRCLIP           | CIRCLIP            | CIRCLIP             | 2 273 8 30  |     |
| 29       | 339 2270  | 1          | SCHALTRUFFE       | SHIFT SLEEVE      | MANCHON COMMANDE   | MANGUITO CAMBIO     | 1434-14-01-01   |     |
| 30       | 110 7737  | 1          | SICHERUNGSRING    | CIRCLIP           | CIRCLIP            | CIRCLIP             | 25X1,2 DIN 471  |     |
| 31       | 230 7597  | 1          | ANTRIEBSWELLE     | DRIVE SHAFT       | ARBRE DE COMMANDE  | EJE MOTRIZ          | Z 13  |     |

| Bld<br>Nr. | Teil-Nr. | Stück-<br>Zahl | Deutsch          | English        | Français          | Español             | Nummer/Bemerkung   | ETK |
|------------|----------|----------------|------------------|----------------|-------------------|---------------------|--|-----|
| 42         | 230 7911 | 1              | ZAHNRAD          | GEAR           | ROUE DENTEE       | RUEDA DENTADA       | Z 50   |     |
| 43         | 230 7912 | 1              | ZAHNRAD          | GEAR           | ROUE DENTEE       | RUEDA DENTADA       | Z 44<br>8027. BIS FAHRGESTELL-NO.<br>8004. AB FAHRGESTELL-NO. POS. 48                                |     |
| 44         | 230 7909 | 1              | MUFFENTRAEGER    | SOCKET CARRIER | PORTE-MANCHON     | PORTAMANGUITO       |  |     |
| 45         | 230 7910 | 1              | BUECHSE          | BUSH           | BOITE             | CASQUILLO           |  |     |
| 46         | 116 1513 | 2              | NADELKAEFIG      | NEEDLE GAGE    | CAGE A AIGUILLES  | JAULA AGUJAS        | K 44 X 50X22 H 4455  | 01  |
| 47         | 230 9682 | 1              | ZAHNRAD          | GEAR           | ROUE DENTEE       | RUEDA DENTADA       | Z 22   |     |
| 48         | 230 9683 | 1              | ZAHNRAD          | GEAR           | ROUE DENTEE       | RUEDA DENTADA       | Z 47   |     |
| 53         | 232 9248 | 1              | ZAPFWELLENSCHUTZ | PTO GUARD      | GARDE PRISE FORCE | PROTEC. TOMA FUERZA |  |     |
| 54         | 238 4202 | 1              | ZAPFWELLE        | PTO SHAFT      | ARBRE P.-D.-F.    | ARBOL TOMA FUERZA   | 8042. BEI ERSTMALIGEM ERSATZ<br>BIS FAHRGESTELL-NO<br>7876/8054. 7868/0479<br>POS. 55+56 MITLIEFERN. |     |
| 55         | 238 4203 | 1              | LAGERDECKEL      | BEARING CAP    | CHAPEAU DE PALIER | TAPA SOPORTE        | 8042. BEI ERSTMALIGEM ERSATZ<br>BIS FAHRGESTELL-NO<br>7876/8054. 7868/0479<br>POS. 54+56 MITLIEFERN  |     |
| 56         | 117 2223 | 1              | WELLENDICHTRING  | SHAFT SEAL     | JOINT D ARBRE     | ANILLO HERMET. EJE  | S 38X 52 X 7 H 2940-NI   | 01  |
| 950        | 230 1712 | NB             | BEILAGE          | SHIM           | CALE              | SUPLEMENTO          | A 1.6 MM   |     |
| 951        | 230 1713 | NB             | BEILAGE          | SHIM           | CALE              | SUPLEMENTO          | A 1.8 MM   |     |
| 952        | 230 1714 | NB             | BEILAGE          | SHIM           | CALE              | SUPLEMENTO          | A 2.0 MM   |     |
| 953        | 230 1715 | NB             | BEILAGE          | SHIM           | CALE              | SUPLEMENTO          | A 2.2 MM   |     |
| 954        | 230 1716 | NB             | BEILAGE          | SHIM           | CALE              | SUPLEMENTO          | A 2.4 MM   |     |
| 955        | 230 1717 | NB             | BEILAGE          | SHIM           | CALE              | SUPLEMENTO          | A 2.6  |     |

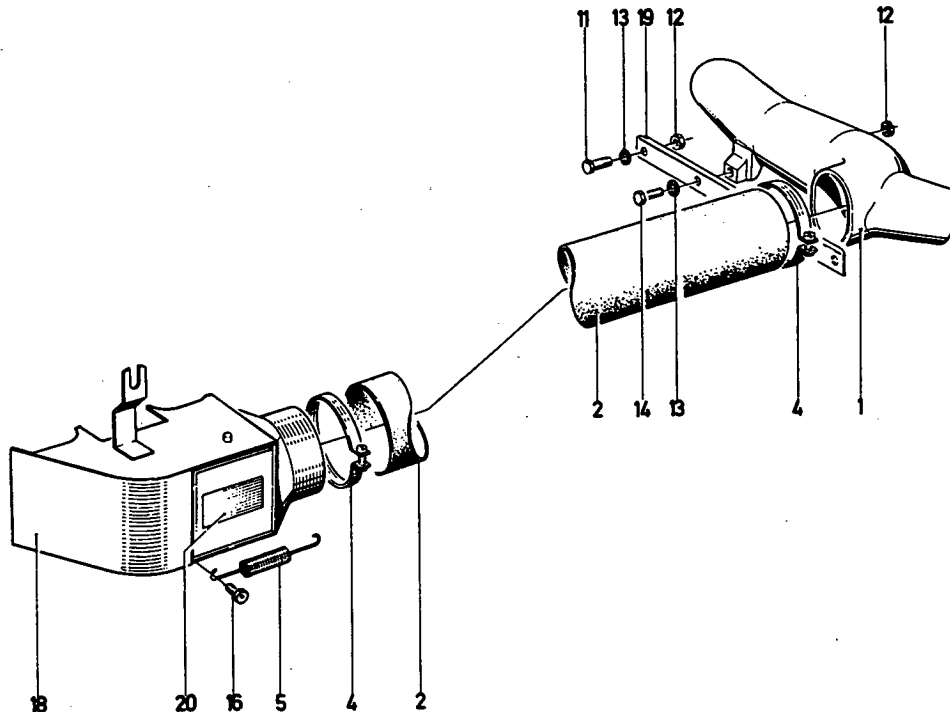

1003-85 500 4250

| Bkl<br>Nr. | Teil-Nr  | Stück-<br>Zahl | Deutsch           | English        | Français           | Español            | Nummer/Bemerkung         | ETK |
|------------|----------|----------------|-------------------|----------------|--------------------|--------------------|--------------------------|-----|
| 1          | 338 9902 | 1              | DUESE             | NOZZLE         | INJECTEUR/GICLÉUR  | TOBERA             | 1152-95-02-03            |     |
| 2          | 338 9517 | 1              | HEIZSCHLAUCH      | HEATING HOSE   | FLEXIBLE DE CHAUFF | MANGUERA CALEFACC- | 1145-95-01-03            |     |
| 4          | 112 8273 | 2              | SCHLAUCHSCHELLE   | HOSE CLIP      | COLLIER SERRAGE    | ABRAZADERA MANGUER | SA 60- 80DIN 3017-ST     |     |
| 5          | 338 9239 | 1              | ZUGFEDER          | DRAW SPRING    | RESSORT TRACTION   | RESORTE TRACCION   | 1136-95-07-04            | 01  |
| 11         | 111 2251 | 2              | SECHSKANTSCHRAUBE | HEX.BOLT       | VIS 6 PANS         | TORNILLO HEXAGONAL | M 6X 15 DIN 933- 8-8-A4C |     |
| 12         | 111 2813 | 4              | SECHSKANTMUTTER   | HEX-NUT        | ECROU 6 PANS       | TUERCA HEXAGONAL   | M 6 DIN 934-M 8 A4C      |     |
| 13         | 116 7194 | 4              | SICHERUNGSSCHEIBE | LOCKING WASHER | RONDELLE SECURITE  | ARANDELA SEGURIDAD | 6 M 2203                 |     |
| 14         | 112 3749 | 2              | SECHSKANTSCHRAUBE | HEX-BOLT       | VIS 6 PANS         | TORNILLO HEXAGONAL | M 6X 25 DIN 933- 8-8-A4C |     |
| 16         | 111 2299 | 1              | SECHSKANTSCHRAUBE | HEX-BOLT       | VIS 6 PANS         | TORNILLO HEXAGONAL | M 8X 12 DIN 933- 8-8-A4C |     |
| 18         | 231 1114 | 1              | HEIZKASTEN        | HEATING BOX    | BOITE DE CHAUFFAGE | CAJA CALEFACCION   |                          |     |
| 19         | 231 1730 | 1              | STREBE            | BRACE/STRUT    | JAMBE DE FORCE     | TIRANTE            |                          |     |
| 20         | 121 3712 | 1              | FIRMENSCHILD      | NAMEPLATE/NAME | PLAQUE DE FIRME    | ROTULO FABRICA     | 4 303 A 246              |     |

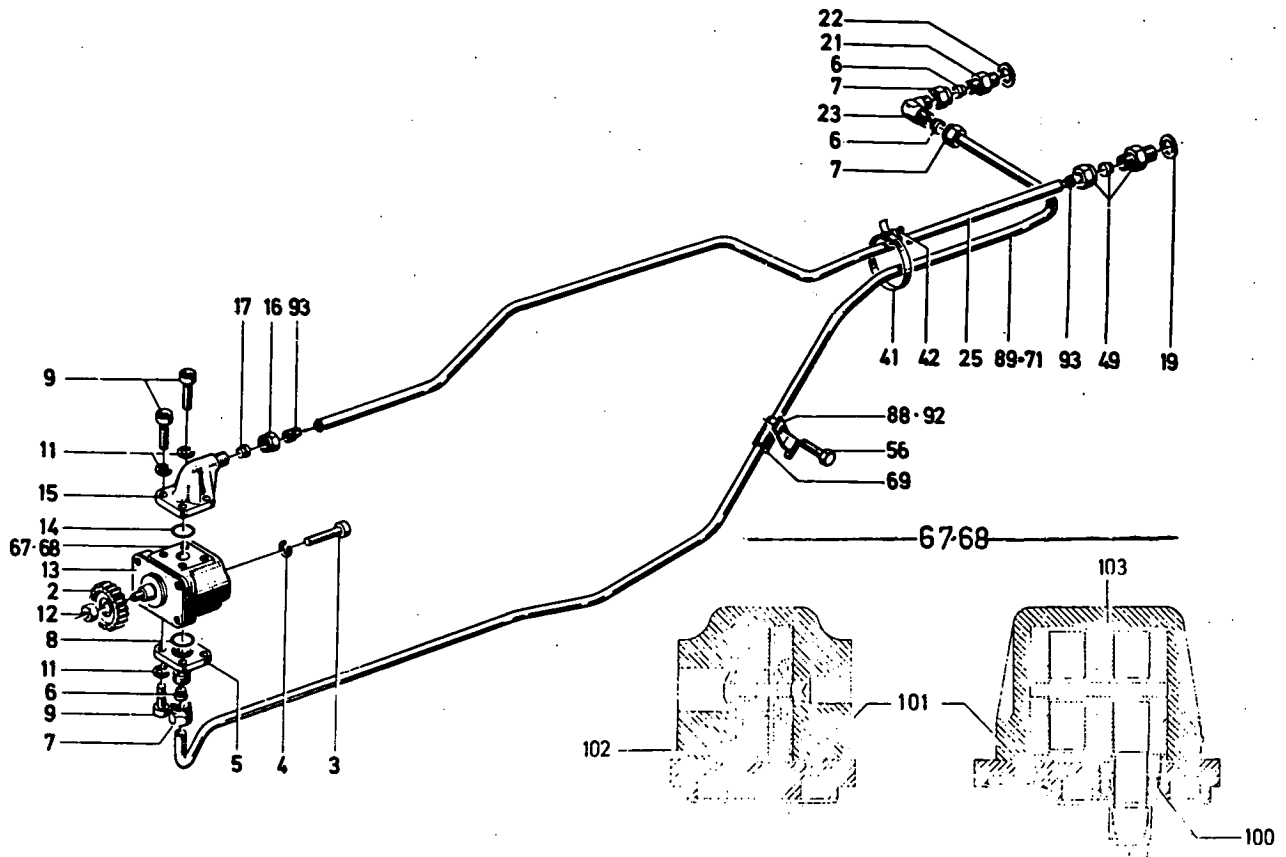

1926-01 500 4251

| Bld Nr. | Teile-Nr. | Stück-Zahl | Deutsch            | English           | Français           | Español            | Numer / Bemerkung         | ETK |
|---------|-----------|------------|--------------------|-------------------|--------------------|--------------------|---------------------------|-----|
| 2       | 340 0561  | 1          | ZAHNRAD            | GEAR              | ROUE DENTEE        | RUEDA DENTADA      | 1940-01-24-02             |     |
| 3       | 111 0682  | 2          | ZYLINDERSCHRAUBE   | CHEESE-HEAD SCREW | VIS TETE CYLINDR.  | TORN-CBZA-CILIND.  | M10X 4SDIN 912- 8-8 ANC   |     |
| 4       | 111 9613  | 2          | FEDERRING          | SPRING LOCKWASHER | RONDELLE GROWER    | ARANDELA ELASTICA  | 10DIN 7980 VZKC           |     |
| 5       | 340 0563  | 1          | FLANSCHSTUTZEN     | FLANGED SOCKET    | TUBUL A REBORD     | TUBULAD-BRIDA      | 1940-01-24-05             |     |
| 6       | 111 6626  | 3          | SCHNEIDRING        | CUTTING RING      | BAGUE TRCHANTE     | ANILLO CORTANTE    | L 15DIN 3861-ST           |     |
| 7       | 111 6653  | 3          | UEBERWURFMUTTER    | UNION NUT         | ECROU-RACCORD      | TUERCA EMPALME     | AL 15DIN 3870 VZKC        |     |
| 8       | 116 6015  | 1          | RUNDGUMMRING       | O-SEAL            | ANNEAU TORIQUE     | ANILLO GOMA REDOND | 18 X 2,5 H 721            | 01  |
| 9       | 111 0517  | 8          | ZYLINDERSCHRAUBE   | CHEESE-HEAD SCREW | VIS TETE CYLINDR.  | TORN-CBZA-CILIND.  | M 6X 22DIN 912-10-9-ANC   |     |
| 11      | 111 9609  | 8          | FEDERRING          | SPRING LOCKWASHER | RONDELLE GROWER    | ARANDELA ELASTICA  | 6DIN 7980 VZKC            |     |
| 12      | 112 2569  | 1          | SECHSKANTMUTTER    | HEX-NUT           | ECROU 6 PANS       | TUERCA HEXAGONAL   | M12X1,5DIN 985- 8 VZKC    |     |
| 13      | 336 4291  | 1          | DICHTUNG           | GASKET            | GARNITURE/JOINT    | JUNTA              | 0150-83-09-07             |     |
| 14      | 116 6033  | 1          | RUNDGUMMRING       | O-SEAL            | ANNEAU TORIQUE     | ANILLO GOMA REDOND | 25 X 2,5 H 721            | 01  |
| 15      | 340 0736  | 1          | FLANSCHSTUTZEN     | FLANGED SOCKET    | TUBUL A REBORD     | TUBULAD-BRIDA      | 1941-01-01-29             |     |
| 16      | 111 6656  | 1          | UEBERWURFMUTTER    | UNION NUT         | ECROU-RACCORD      | TUERCA EMPALME     | AL 22DIN 3870 VZKC        |     |
| 17      | 111 6629  | 1          | SCHNEIDRING        | CUTTING RING      | BAGUE TRCHANTE     | ANILLO CORTANTE    | L 22DIN 3861-ST           |     |
| 19      | 111 8760  | 1          | DICHTRING          | WASHER            | BAGUE D ETANCHEITE | ANILLO DE JUNTA    | A 26 X 31 DIN 7603-CU     |     |
| 21      | 111 6687  | 1          | EINSCHRAUBSTUTZEN  | SCREW-IN NIPPLE   | TUBULURE A VIS     | TUBULAD-ENROSCADA  | L 15M DIN 3901 VZKC       |     |
| 22      | 111 8713  | 1          | DICHTRING          | WASHER            | BAGUE D ETANCHEITE | ANILLO DE JUNTA    | A 18 X 22 DIN 7603-CU     |     |
| 23      | 116 4939  | 1          | VERBINDUNGSSTUTZEN | UNION             | RACCORD            | TUBULADURA UNION   | 8L15 H 7170               |     |
| 25      | 347 4284  | 1          | SAUGLEITUNG        | SUCTION LINE      | CONDUITE ASPIRAT   | TUBERIA ASPIRACION | 1941-01-08-25             |     |
| 41      | 116 9594  | 1          | SCHLAUCHBAND       | HOSE STRAP        | RUBAN SERRAGE      | CINTA ATAMANGUEPA  | 9 9X 230 H 735            |     |
| 42      | 116 6343  | 1          | SCHLAUCHBINDER     | HOSE FASTENER     | ATTACHE RUBAN      | ATAPANGUERA        | A H 735                   |     |
| 49      | 121 0596  | 1          | VERSCHRAUBUNG      | THREADED UNION    | RACCORD VISSE      | UNION POSC P/TUBO  | 7 110 A                   |     |
| 56      | 111 2391  | 1          | SECHSKANTSCHRAUBE  | HEX-BOLT          | VIS 6 PANS         | TORNILLO HEXAGONAL | M10X 1,5 DIN 933- 8-8-ANC |     |
| 67      | 126 2637  | 1          | HYDRAULIKPUMPE     | HYDRAULIC PUMP    | POMPE HYDRAULIQUE  | BOMBA HIDRAULICA   | 11CCM P/UM<br>W8.         |     |

| Bld. Nr. | Teil-Nr. | Stück-Zahl | Deutsch            | English           | Français           | Español            | Nummer/Bemerkung                             | ETK |
|----------|----------|------------|--------------------|-------------------|--------------------|--------------------|--|-----|
| 68       | 126 2639 | 1          | HYDRAULIKPUMPE     | HYDRAULIC PUMP    | POMPE HYDRAULIQUE  | BOMBA HIDRAULICA   | 14CCN P/UM                                   |     |
| 69       | 230 3354 | 1          | RUFFE              | SLEEVE            | HANCHON            | MANGUITO           |  |     |
| 71       | 233 3869 | 1          | BRUCKLEITUNG       | DELIVERY LINE     | CONDUITE DE REFOUL | TUBERIA PRESION    | 8231-NUR FUER PLANTAGENSCHLEP<br>PER D4006 P |     |
| 88       | 116 3063 | 1          | ROHRSCHELLE        | PIPE CLIP         | COLLIER PR TUBES   | ABRAZADERA DE TUBO | 823 H 3201 VZKC                              |     |
| 89       | 233 3862 | 1          | BRUCKLEITUNG       | DELIVERY LINE     | CONDUITE DE REFOUL | TUBERIA PRESION    |  |     |
| 92       | 237 0100 | 1          | ROHRSCHELLE        | PIPE CLIP         | COLLIER PR TUBES   | ABRAZADERA DE TUBO |  |     |
| 93       | 117 2278 | 2          | VERSTAERKGS-HUELSE | STIFFENING SLEEVE | DOUILLE RENFORT    | CASQUILLO REFUERZO | A22X1 H 3111-ST                              |     |
| 100      | 130 0154 | 1          | DICHTUNG           | GASKET            | GARNITURE/JOINT    | JUNTA              |  |     |
| 101      | 129 8473 | 1          | DICHTRING          | WASHER            | BAGUE D ETANCHEITE | ANILLO DE JUNTA    |  |     |
| 102      | 129 8722 | 2          | DICHTRING          | WASHER            | BAGUE D ETANCHEITE | ANILLO DE JUNTA    |  |     |
| 103      | 130 0174 | 2          | DICHTRING          | WASHER            | BAGUE D ETANCHEITE | ANILLO DE JUNTA    |  |     |





HYDR. PUMPE MIT LEITUNGEN (HYDRO-LENKUNG)  
 HYDRAULIC PUMP WITH PIPING (TRACTOR WITH HYDRAULIC STEERING SYSTEM)  
 POMPE HYDRAULIQUE ET CONDUITS (VERSION AVEC DIRECTION HYDRO-ASSISTEE)  
 BOMBA HIDRAULICA CON TUBERIAS (EJECUCION CON SERVO-DIRECCION HIDRAULICA)

1926-01 5004252

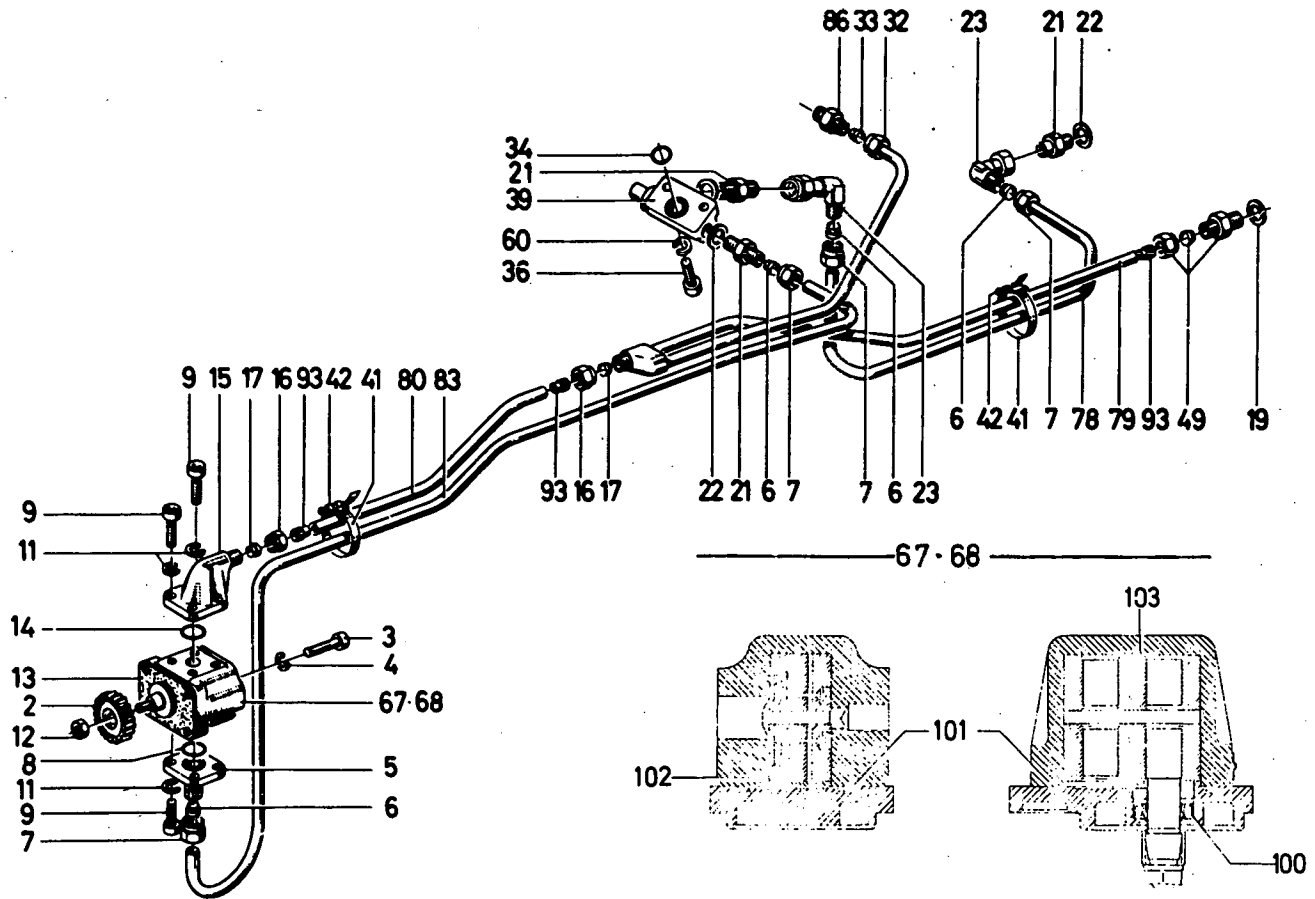

1926-01 500 4252

| Bld Nr. | Teile-Nr. | Stück-Zahl | Deutsch           | English            | Français           | Español            | Nummer/Bemerkung        | ETK |
|---------|-----------|------------|-------------------|--------------------|--------------------|--------------------|-------------------------|-----|
| 2       | 340 0561  | 1          | ZAHNRAD           | GEAR               | ROUE DENTEE        | RUEDA DENTADA      | 1940-01-24-02           |     |
| 3       | 111 0682  | 2          | ZYLINDERSCHRAUBE  | CHEESE-HEAD SCREW  | VIS TETE CYLINDR.  | TORN-CBZA.CILIND.  | M10X 45DIN 912- 8-8 A4C |     |
| 4       | 111 9613  | 2          | FEDERRING         | SPRING LOCKWASHER  | RONDELLE GROUPE    | ARANDELA ELASTICA  | 10DIN 7983 VZKC         |     |
| 5       | 340 0563  | 1          | FLANSCHSTUTZEN    | FLANGED SOCKET     | TUBUL A REBORD     | TUBULAD-BRIDA      | 1940-01-24-05           |     |
| 6       | 111 6626  | 6          | SCHNEIDRING       | CUTTING RING       | BAGUE TRCHANANTE   | ANILLO CORTANTE    | L 15DIN 3861-ST         |     |
| 7       | 111 6653  | 6          | UEBERWURFMUTTER   | UNION NUT          | ECROU-RACCORD      | TUERCA EMPALME     | AL 15DIN 3870 VZKC      |     |
| 8       | 116 6015  | 1          | RUNDGUMMRING      | O-SEAL             | ANNEAU TORIQUE     | ANILLO GOMA REDOND | 18 X 2.5 H 721          | 01  |
| 9       | 111 0517  | 8          | ZYLINDERSCHRAUBE  | CHEESE-HEAD SCREW  | VIS TETE CYLINDR.  | TORN-CBZA.CILIND.  | M 8X 22DIN 912-10-9-A4C |     |
| 11      | 111 9609  | 8          | FEDERRING         | SPRING LOCKWASHER  | RONDELLE GROUPE    | ARANDELA ELASTICA  | 6DIN 7983 VZKC          |     |
| 12      | 112 2569  | 1          | SECHSKANTMUTTER   | HEX-NUT            | ECROU 6 PANS       | TUERCA HEXAGONAL   | M12X1,5DIN 985- 8 VZKC  |     |
| 13      | 336 4291  | 1          | DICHTUNG          | GASKET             | GARNITURE/JOINT    | JUNTA              | 0150-83-09-07           |     |
| 14      | 116 6033  | 1          | RUNDGUMMRING      | O-SEAL             | ANNEAU TORIQUE     | ANILLO GOMA REDOND | 25 X 2.5 H 721          | 01  |
| 15      | 340 0736  | 1          | FLANSCHSTUTZEN    | FLANGED SOCKET     | TUBUL A REBORD     | TUBULAD-BRIDA      | 1941-01-01-29           |     |
| 16      | 111 6656  | 2          | UEBERWURFMUTTER   | UNION NUT          | ECROU-RACCORD      | TUERCA EMPALME     | AL 22DIN 3870 VZKC      |     |
| 17      | 111 6629  | 2          | SCHNEIDRING       | CUTTING RING       | BAGUE TRCHANANTE   | ANILLO CORTANTE    | L 22DIN 3861-ST         |     |
| 19      | 111 8760  | 1          | DICHRING          | WASHER             | BAGUE D ETANCHEITE | ANILLO DE JUNTA    | A 26 X 31 DIN 7603-CU   |     |
| 21      | 111 6687  | 3          | EINSCHRAUBSTUTZEN | SCREW-IN NIPPLE    | TUBULURE A VIS     | TUBULAD-ENROSCADA  | L 15M DIN 3901 VZKC     |     |
| 22      | 111 8713  | 3          | DICHRING          | WASHER             | BAGUE D ETANCHEITE | ANILLO DE JUNTA    | A 18 X 22 DIN 7603-CU   |     |
| 23      | 116 0075  | 2          | VERBINDUNGSSUTZEN | UNION              | RACCORD            | TUBULADURA UNION   | L15H 3133 VZKC          |     |
| 32      | 112 2817  | 1          | UEBERWURFMUTTER   | UNION NUT          | ECROU-RACCORD      | TUERCA EMPALME     | AL 12DIN 3870 VZKC      |     |
| 33      | 111 6624  | 1          | SCHNEIDRING       | CUTTING RING       | BAGUE TRCHANANTF   | ANILLO CORTANTE    | L 12DIN 3861-ST         |     |
| 34      | 116 0038  | 1          | O-RING            | O-SEAL             | BAGUE TORIQUE      | ANILLO O           | 10 X3 H 2927-G1 DEUTZ 9 | 01  |
| 36      | 111 0561  | 2          | ZYLINDERSCHRAUBE  | CHEESE-HEAD SCREW  | VIS TETE CYLINDR.  | TORN-CBZA.CILIND.  | M 8X 20DIN 912-10-9-A4C |     |
| 39      | 340 0761  | 1          | REGLER            | GOVERNOR/REGULATOR | REGULATEUR         | REGILADOR          | 1941-01-04-59           |     |
| 41      | 116 9594  | 2          | SCHLAUCHBAND      | HOSE STRAP         | PUBAN SEPRAGE      | CINTA ATAMANGUEPA  | B 9X 230 H 735          |     |
| 42      | 116 6343  | 2          | SCHLAUCHBINDER    | HOSE FASTENER      | ATTACHE PUBAN      | ATAMANGUERA        | A H 735                 |     |

| Bld Nr. | Teile-Nr. | Stück-Zahl | Deutsch            | English           | Français           | Español            | Nummer/Bemerkung         | ETK |
|---------|-----------|------------|--------------------|-------------------|--------------------|--------------------|--------------------------|-----|
| 49      | 121 0596  | 1          | VERSCHRAUBUNG      | THREADED UNION    | RACCORD VISSE      | UNION ROSC P/TUBO  | 3 110 A                  |     |
| 60      | 111 9611  | 2          | FEDERRING          | SPRING LOCKWASHER | RONDELLE GROUVER   | ARANDELA ELASTICA  | 8DIN 7980 VZKC           |     |
| 67      | 126 2637  | 1          | HYDRAULIKPUMPE     | HYDRAULIC PUMP    | POMPE HYDRAULIQUE  | BOMBA HIDRAULICA   | 13 CCM PRO UMDR-175 ATUE |     |
| 68      | 126 2639  | 1          | HYDRAULIKPUMPE     | HYDRAULIC PUMP    | POMPE HYDRAULIQUE  | BOMBA HIDRAULICA   | 14 CCM PRO UMDR-175 ATUE |     |
| 78      | 233 3865  | 1          | DRUCKLEITUNG       | DELIVERY LINE     | CONDUITE DE REFOUL | TUBERIA PRESION    |                          |     |
| 79      | 232 3749  | 1          | SAUGLEITUNG        | SUCTION LINE      | CONDUITE ASPIRAT   | TUBERIA ASPIRACION |                          |     |
| 80      | 232 2538  | 1          | SAUGLEITUNG        | SUCTION LINE      | CONDUITE ASPIRAT   | TUBERIA ASPIRACION |                          |     |
| 83      | 233 5351  | 1          | DRUCKLEITUNG       | DELIVERY LINE     | CONDUITE DE REFOUL | TUBERIA PRESION    |                          |     |
| 86      | 112 2822  | 1          | EINSCHRAUBSTUTZEN  | SCREW-IN NIPPLE   | TUBULOPE A VIS     | TUBULAD.FNROSCADA  | L 12M DTN 3901 VZKC      |     |
| 93      | 117 2278  | 3          | VERSTAERKGS-WUELSE | STIFFENING SLEEVE | DOUILLE RENFORT    | CASQUILLO REFUERZO | A22X1 H 3111-ST          |     |
| 100     | 130 0154  | 1          | DICHTUNG           | GASKET            | GARNITURE/JOINT    | JUNTA              |                          |     |
| 101     | 129 8473  | 1          | DICHTRING          | WASHER            | BAGUE D ETANCHEITE | ANILLO DE JUNTA    |                          |     |
| 102     | 129 8722  | 2          | DICHTRING          | WASHER            | BAGUE D ETANCHEITE | ANILLO DE JUNTA    |                          |     |
| 103     | 130 0174  | 2          | DICHTRING          | WASHER            | BAGUE D ETANCHEITE | ANILLO DE JUNTA    |                          |     |

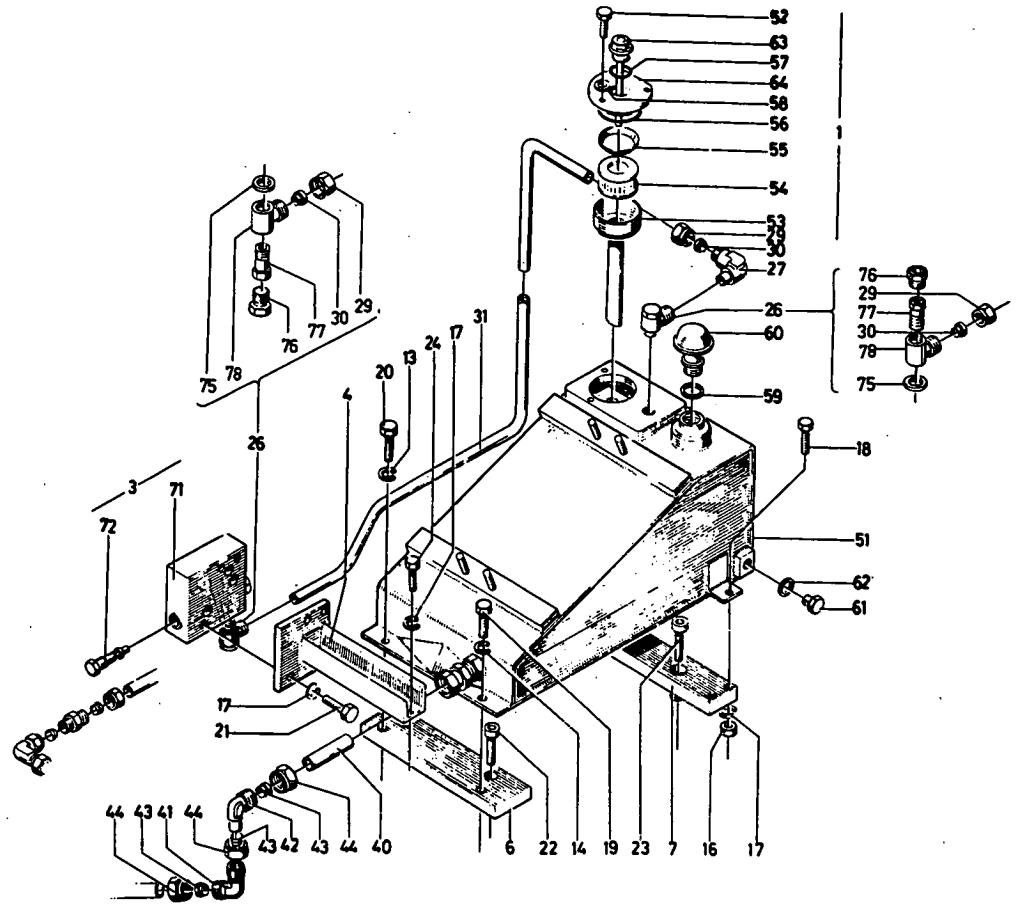

1926-04 500 5139

| Bldg Nr. | Teile-Nr. | Stück-Zahl | Deutsch            | English           | Français           | Español            | Nummer/Bemerkung                 | ETK |
|----------|-----------|------------|--------------------|-------------------|--------------------|--------------------|----------------------------------|-----|
| 1        | 230 1137  | 1          | OELBEHAELTER       | OIL RESERVOIR     | RESERVOIR D HUILE  | TANQUE ACEITE      | 8199,15 LITER                    |     |
| 3        | 231 3119  | 1          | SOCKEL             | BASE/PEDESTAL     | SOCLE              | ZOCALO             | 8347-VOLLSTAENDIG MIT POS. 71+72 |     |
| 4        | 231 3111  | 1          | HALTER             | RETAINER          | SUPPORT/PORTEOUTIL | SOPORTE            |                                  |     |
| 6        | 231 3122  | 1          | HALTER             | RETAINER          | SUPPORT/PORTEOUTIL | SOPORTE            | 8346,VORN                        |     |
| 7        | 231 3126  | 1          | HALTER             | RETAINER          | SUPPORT/PORTEOUTIL | SOPORTE            | 8150,HINTEN                      |     |
| 13       | 110 2802  | 1          | FEDERRING          | SPRING LOCKWASHER | RONDELLE GROUER    | ARANDELA ELASTICA  | A 14 DIN 128 A4C                 |     |
| 14       | 110 2800  | 1          | FEDERRING          | SPRING LOCKWASHER | RONDELLE GROUER    | ARANDELA ELASTICA  | A 10 DIN 128 A4C                 |     |
| 16       | 111 2824  | 3          | SECHSKANTMUTTER    | HEX.NUT           | ECROU 6 PANS       | TUEPCA HEXAGONAL   | M 8 DIN 934-M 8 A4C              |     |
| 17       | 110 2799  | 8          | FEDERRING          | SPRING LOCKWASHER | RONDELLE GROUER    | ARANDELA ELASTICA  | A 8 DIN 128 A4C                  |     |
| 18       | 111 1145  | 3          | SECHSKANTSCHRAUBE  | HEX.BOLT          | VIS 6 PANS         | TORNILLO HEXAGONAL | M 8X 40 DIN 931-M 8-B A4C        |     |
| 19       | 111 2407  | 1          | SECHSKANTSCHRAUBE  | HEX.BOLT          | VIS 6 PANS         | TORNILLO HEXAGONAL | M10X 20 DIN 933- 8-B-A4C         |     |
| 20       | 111 2596  | 1          | SECHSKANTSCHRAUBE  | HEX.BOLT          | VIS 6 PANS         | TORNILLO HEXAGONAL | M14X 20 DIN 933-M 8-B VZKC       |     |
| 21       | 111 2333  | 3          | SECHSKANTSCHRAUBE  | HEX.BOLT          | VIS 6 PANS         | TORNILLO HEXAGONAL | M 8X 25 DIN 933- 8-B-A4C         |     |
| 22       | 112 6136  | 2          | ZYLINDERSCHRAUBE   | CHEESE-HEAD SCREW | VIS TETE CYLINDR.  | TOPN.CBZA.CILIND.  | M10X 55DIN 912- 8-B A4C          |     |
| 23       | 112 2372  | 2          | ZYLINDERSCHRAUBE   | CHEESE-HEAD SCREW | VIS TETE CYLINDR.  | TOPN.CBZA.CILIND.  | M14X 55DIN 912- 8-B-A4C          |     |
| 24       | 110 2194  | 2          | SECHSKANTSCHRAUBE  | HEX.BOLT          | VIS 6 PANS         | TORNILLO HEXAGONAL | M 8X 18DIN 912- 8-B A4C          |     |
| 26       | 126 6006  | 2          | SCHWENKVERSCHRAUBE | SWIVEL PIPE UNION | RACCORD ORIENTABLE | UNION ROSCADA PIVO | 4731-29-01-20                    |     |
| 27       | 116 4939  | 1          | WINKELSTUTZEN      | ELBOW             | RACCORD COUDE      | TUBULADURA ANGULAR | L15H 3130 VZKC                   |     |
| 29       | 111 6653  | 2          | UEBERWURFMUTTER    | UNION NUT         | ECROU-RACCORD      | TUERCA EMPALME     | AL 15DIN 3870 VZKC               |     |
| 30       | 111 6627  | 2          | SCHNEIDRING        | CUTTING RING      | RAGUE TRANCHANTE   | ANILLO CORTANTE    | L 15DIN 3861-ST VZKC             |     |
| 31       | 231 3139  | 1          | RUECKLAUFROHR      | RETURN PIPE       | TUYAU DE RETOUR    | TUBO RETORNO       |                                  |     |
| 40       | 233 8379  | 1          | ROHR               | PIPE/TUBE         | TUBE/TUYAU         | TUBO               |                                  |     |
| 41       | 111 6735  | 1          | WINKELSTUTZEN      | ELBOW             | RACCORD COUDE      | TUBULADURA ANGULAR | L 22DIN 3905                     |     |

| Bild Nr. | Teil-Nr. | Stück-Zahl | Deutsch            | English           | French             | Spanish            | Nummer/Bemerkung         | ETK |
|----------|----------|------------|--------------------|-------------------|--------------------|--------------------|--------------------------|-----|
| 42       | 116 9835 | 1          | WINKELSTUTZEN      | ELBOW             | RACCORD COUDE      | TUBULADURA ANGULAR | L22H 3130                |     |
| 43       | 111 6629 | 3          | SCHNEIDRING        | CUTTING RING      | BAGUE TRANCHANTE   | ANILLO CORTANTE    | L 22DIN 3861-ST          |     |
| 44       | 111 6656 | 3          | UEBERWURFMUTTER    | UNION NUT         | ECROU-RACCORD      | TUERCA EMPALME     | AL 22DIN 3870 VZKC       |     |
| 51       | 230 1139 | 1          | ÖLBEHAELTER        | OIL RESERVOIR     | RESERVOIR D HUILE  | TANQUE ACEITE      |                          |     |
| 52       | 111 2251 | 3          | SECHSKANTSCHRAUBE  | HEX-BOLT          | VIS 6 PANS         | TORNILLO HEXAGONAL | M 6X 15 DIN 933- 8.8-A4C |     |
| 53       | 340 0806 | 1          | TOPF               | CUP               | POT                | COPA/CAJA/MACETA   | 1941-08-01-41            |     |
| 54       | 340 0802 | 1          | FILTREINSATZ       | ELEMENT           | CART.FILTRANTE     | ELEMENTO FILTRO    | 1941-08-01-33            | 01  |
| 55       | 340 0816 | 1          | FEDERRING          | SPRING LOCKWASHER | RONDELLE GROUVER   | ARANDELA ELASTICA  | 1941-08-01-128           |     |
| 56       | 116 9587 | 1          | RUNDGUMMRING       | O-SEAL            | ANNEAU TORIQUE     | ANILLO GOMA REDOND | 63 X 2 H 721             | 01  |
| 57       | 238 0742 | 1          | DICHTRING          | WASHER            | BAGUE D ETANCHEITE | ANILLO DE JUNTA    |                          | 01  |
| 58       | 110 7095 | 3          | SCHWEIBE           | DISC/PANE/PLATE   | RONDELLE/DISQUE    | DISCO              | A 6.4DIN 125-ST-A4C      |     |
| 59       | 111 8784 | 1          | DICHTRING          | WASHER            | BAGUE D ETANCHEITE | ANILLO DE JUNTA    | A 30 X 36 DIN 7603-CU    |     |
| 60       | 126 6675 | 1          | ENTLUEFTUNGSFILTER | BREATHER FILTER   | FILTRE D AIR VENT  | FILTRO VENTILAC.   | 8741-30-08-01            |     |
| 61       | 111 8965 | 1          | VERSCHLUSSSCHRAUBE | SCREW PLUG        | BOUCHON FILETE     | TAPON ROSCADO      | AM16X1.5 DIN 7604 VZKC   |     |
| 62       | 111 8707 | 1          | DICHTRING          | WASHER            | BAGUE D ETANCHEITE | ANILLO DE JUNTA    | A 16 X 22 DIN 7603-CU    |     |
| 63       | 237 0130 | 1          | MESSSTAB           | GAUGE STICK       | JAUGE              | VARILLA MEDICION   |                          |     |
| 64       | 340 0803 | 1          | FILTERDECKEL       | COVER             | COUVERCLE DE FILTR | TAPA FILTRO        | 1941-08-01-34            |     |
| 71       | 231 3118 | 1          | SOCKEL             | BASE/PEDESTAL     | SOCLE              | ZOCALO             |                          |     |
| 72       | 340 1392 | 1          | PATRONE            | CARTRIDGE         | CARTOUCHE          | CARTUCHO           | 1952-06-05-136           |     |
| 75       | 116 7962 | 2          | DICHTKANTENRING    | SEALING RING      | BAGUE-JOINT        | ARO CANTO HERMET.  | 18M H 3138               |     |
| 76       | 116 4872 | 1          | VERSCHLUSSSCHRAUBE | SCREW PLUG        | BOUCHON FILETE     | TAPON ROSCADO      | AM 24X1.5 H 3139-A4C     |     |
| 77       | 116 7971 | 1          | BUNDSCHRAUBE       | COLLAR SCREW      | VIS A COLLET       | TORNILLO COLLARIN  | 8M 18X1.5 H 3139         |     |
| 78       | 116 4873 | 1          | GEHAEUSE           | HOUSING/CASE      | CARTER/BOITIER     | CAJA/BLOQUE/CUERPO | WL15M H 3137-A4C         |     |



REMOTE-ANSCHLÜSSE  
 AUXILIARY REMOTE HYDRAULICS (TRACTOR WITH LIFT)  
 RACCORDS DE TELECOMMANDE HYDRAULIQUE  
 EMPALMES PARA CONTROL REMOTO

1926-04 500 5150

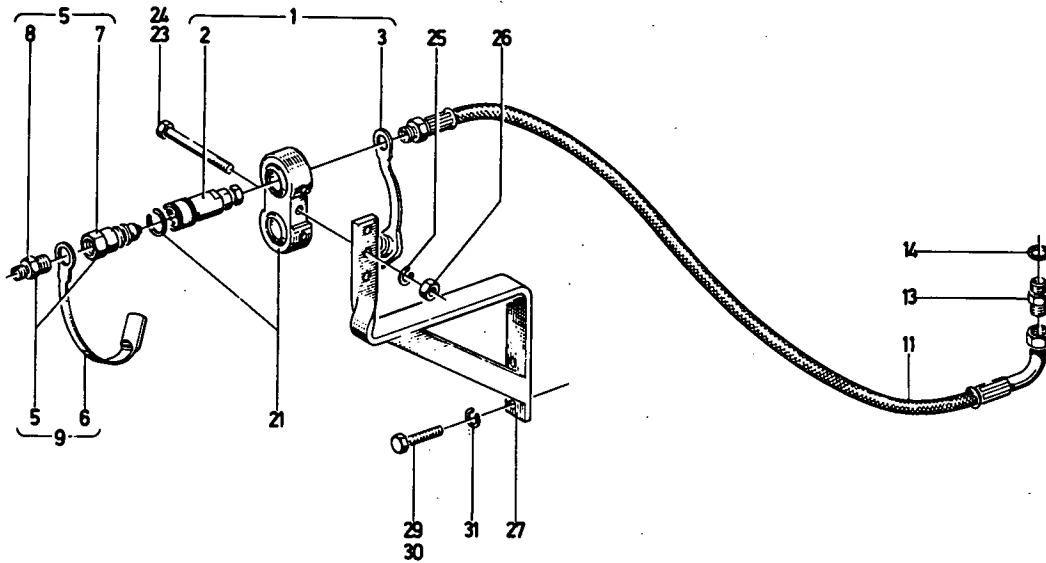

1926-04 500 5150

| Bez. Nr. | Teile-Nr. | Stück-Zahl | Deutsch           | English           | Français           | Español            | Nummer/Bemerkung                               | ETK |
|----------|-----------|------------|-------------------|-------------------|--------------------|--------------------|--|-----|
| 1        | 237 0359  | 1          | STECKDOSE         | SOCKET            | PRISE DE COURANT   | CAJA ENCHUFE       | 8347 VOLLSTÄNDIG MIT POS. 3+3.                 |     |
| 2        | 231 9777  | 1          | KUPPLUNG          | CLUTCH/COUPLING   | ACCOUPL/EMBRAYAGE  | EMBRAGUE/ACOPLE    | 1971-34-27-05                                  |     |
| 3        | 232 1305  | 1          | STECKER           | PLUG              | FICHE DE CONTACT   | CLAVIJA ENCHUFE    | 1941-37-23-03                                  |     |
| 5        | 347 1265  | 1          | STECKER           | PLUG              | FICHE DE CONTACT   | CLAVIJA ENCHUFE    | 1941-37-24-10                                  |     |
| 6        | 231 9366  | 1          | STAUBKAPPE        | DUST CAP          | CAPUCH ANTI-POUSS  | SOMBRES-CONTR-POUV | 1941-37-24-03                                  |     |
| 7        | 231 9364  | 1          | STECKER           | PLUG              | FICHE DE CONTACT   | CLAVIJA ENCHUFE    | 1941-37-24-03                                  |     |
| 8        | 237 3279  | 1          | ADAPTER           | ADAPTER           | RACCORD REDUCTEUR  | ADAPTADOR          |  |     |
| 9        | 231 9363  | 1          | STECKER           | PLUG              | FICHE DE CONTACT   | CLAVIJA ENCHUFE    | 1941-37-24-20<br>9347 VOLLSTÄNDIG MIT POS. 5+5 |     |
| 11       | 237 0350  | 1          | SCHLAUCHLEITUNG   | HOSE              | CONDUITE FLEXIBLE  | MANGUERA           | 8190, 900MM-LANG                               | 01  |
| 13       | 116 0286  | 1          | EINSCHRAUBSTUTZEN | SCREW-IN NIPPLE   | TUBULURE A VIS     | TUBULAD-ENROSCADA  | M18X1,5X12 H 3132                              |     |
| 14       | 111 8713  | 1          | DICHTRING         | WASHER            | BAGUE D ETANCHEITE | ANILLO DE JUNTA    | A 18 X 22 DIN 7603-CU                          |     |
| 21       | 231 3039  | TN         | HALTER            | RETAINER          | SUPPORT/PORTEOUTIL | SOPORTE            | 8286, SIEHE TAFEL-NR<br>1971-07 500 6124       |     |
| 23       | 111 1336  | 1          | SECHSKANTSCHRAUBE | HEX-BOLT          | VIS 6 PANS         | TORNILLO HEXAGONAL | M10X 75 DIN 931- 8-8-A4C                       |     |
| 24       | 112 4803  | 1          | SECHSKANTSCHRAUBE | HEX-BOLT          | VIS 6 PANS         | TORNILLO HEXAGONAL | M10X 130 DIN 931- 8-8-A4C                      |     |
| 25       | 110 2800  | 1          | FEDERRING         | SPRING LOCKWASHER | RONDELLE GROWER    | ARANDELA ELASTICA  | A 10 DIN 128 A4C                               |     |
| 26       | 110 2659  | 1          | SECHSKANTMUTTER   | HEX-NUT           | ECROU 6 PANS       | TUERCA HEXAGONAL   | M10 DIN 934-M 8 A4C                            |     |
| 27       | 237 0314  | 1          | HALTER            | RETAINER          | SUPPORT/PORTEOUTIL | SOPORTE            |  |     |
| 29       | 111 2679  | 2          | SECHSKANTSCHRAUBE | HEX-BOLT          | VIS 6 PANS         | TORNILLO HEXAGONAL | M6X 35 DIN 933-M 8-8 A4C                       |     |
| 30       | 111 2693  | 2          | SECHSKANTSCHRAUBE | HEX-BOLT          | VIS 6 PANS         | TORNILLO HEXAGONAL | M6X 45 DIN 933-M 8-8 A4C                       |     |
| 31       | 110 2803  | 2          | FEDERRING         | SPRING LOCKWASHER | RONDELLE GROWER    | ARANDELA ELASTICA  | A 16 DIN 128 A4C                               |     |

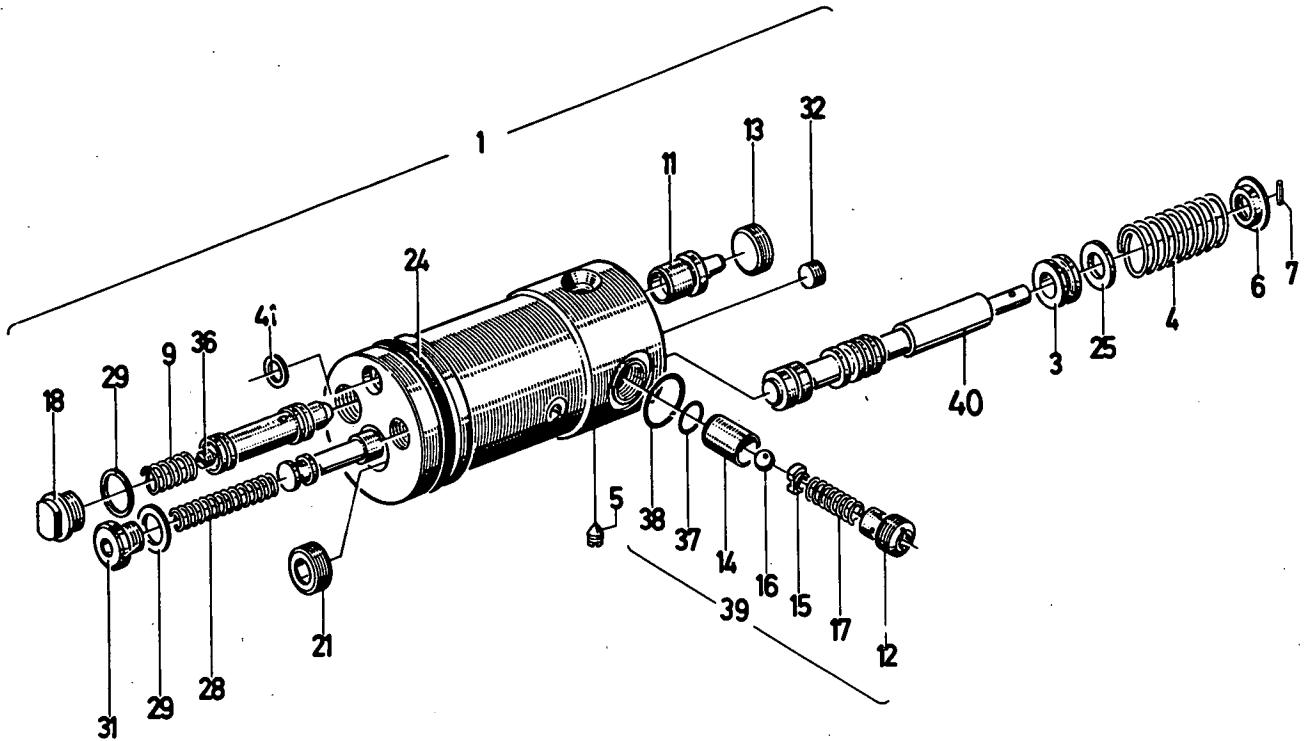

1952-06 500 5132

| Bild Nr | Teil-Nr. | Stück-Zahl | Deutsch            | English            | Français           | Español             | Nummer/Bemerkung           | ETK |
|---------|----------|------------|--------------------|--------------------|--------------------|---------------------|----------------------------|-----|
| 1       | 230 0906 | 1          | STEUERGERÄT        | CONTROL UNIT       | DISTRIBUTEUR       | APARATO MANDO       | 8337 VOLLSTÄNDIG           |     |
| 3       | 230 0903 | 1          | HALTERING          | RETAINING RING     | BAGUE SUPPORT      | ANILLO SUJECION     |                            |     |
| 4       | 340 1306 | 1          | SCHRAUBENFEDER     | HELICAL SPRING     | RESSORT A BOUDIN   | RESORTE HELICOIDAL  | 1952-08-42-04              |     |
| 5       | 110 8012 | 1          | GEWINDESTIFT       | GRUB SCREW         | GOUPILLE FILETEE   | PERNO ROSCADO       | M 6 X 50IN 553- 5-8        |     |
| 6       | 340 1280 | 1          | FEDERTELLER        | SPRING CAP         | CUVETTE DE RESSORT | PLATO RESORTE       | 1952-08-01-06              |     |
| 7       | 111 5400 | 1          | SPANNHUELSE        | DOWEL SLEEVE       | DOUILLE SERRAGE    | CASQUILLO FIADOR    | 2,5 X 120IN 1481           |     |
| 9       | 340 1307 | 1          | SCHRAUBENFEDER     | HELICAL SPRING     | RESSORT A BOUDIN   | RESORTE HELICOIDAL  | 1952-08-42-09              |     |
| 11      | 237 4004 | 1          | STOPFEN            | PLUG               | BOUCHON            | TAPON               |                            |     |
| 12      | 237 7173 | 1          | GEWINDEHUELSE      | THREADED SLEEVE    | DOUILLE FILETEE    | CASQUILLO ROSCADO   |                            |     |
| 13      | 230 0897 | 1          | VERSCHLUSSSCHRAUBE | SCREW PLUG         | BOUCHON FILETE     | TAPON ROSCADO       |                            |     |
| 14      | 237 7174 | 1          | VENTILSITZ         | VALVE SEAT         | SIEGE DE SOUPEPE   | ASIEN TO DE VALVULA |                            |     |
| 15      | 340 1309 | 1          | KUGELSITZ          | BALL SEAT          | SIEGE A ROUTULE    | ASIEN TO BOLA       | 1952-08-42-15              |     |
| 16      | 111 6956 | 1          | KUGEL              | BALL               | BILLE/BOULE        | BOLA                | 8 MM III DIN 5403          |     |
| 17      | 237 7175 | 1          | DRUCKFEDER         | COMPRESSION SPRING | RESSORT DE COMPR   | RESORTE PRESION     | 1952-08-42-17              |     |
| 18      | 230 0899 | 1          | VERSCHLUSSSCHRAUBE | SCREW PLUG         | BOUCHON FILETE     | TAPON ROSCADO       |                            |     |
| 21      | 110 1024 | 1          | VERSCHLUSSSCHRAUBE | SCREW PLUG         | BOUCHON FILETE     | TAPON ROSCADO       | M16X1,5DIN 906- 5-8 PHOSPH |     |
| 24      | 116 6080 | 1          | RUNDGUMMIRING      | O-SEAL             | ANNEAU TORIQUE     | ANILLO GOMA REDOND  | 50 X 4 H 721               | 01  |
| 25      | 110 7553 | 1          | SCHEIBE            | DISC/PANE/PLATE    | RONDELLE/DISQUE    | DISCO               | 13,5DIN 433                |     |
| 28      | 230 0901 | 1          | DRUCKFEDER         | COMPRESSION SPRING | RESSORT DE COMPR   | RESORTE PRESION     |                            |     |
| 29      | 111 8707 | 2          | DICHRING           | WASHER             | BAGUE D ETANCHEITE | ANILLO DE JUNTA     | A 16 X 22 DIN 7603-CU      |     |
| 31      | 112 3687 | 1          | VERSCHLUSSSCHRAUBE | SCREW PLUG         | BOUCHON FILETE     | TAPON ROSCADO       | M16X1,5 DIN 906 PHOSPH     |     |
| 32      | 111 0415 | 1          | VERSCHLUSSSCHRAUBE | SCREW PLUG         | BOUCHON FILETE     | TAPON ROSCADO       | M16X1,5DIN 906- 5-8        |     |
| 36      | 110 7434 | 1          | GEWINDESTIFT       | GRUB SCREW         | GOUPILLE FILETEE   | PERNO ROSCADO       | M 6 X 100IN 437            |     |
| 37      | 230 6576 | 1          | O-RING             | O-SEAL             | BAGUE TORIQUE      | ANILLO O            |                            | 01  |
| 38      | 117 0465 | 1          | O-RING             | O-SEAL             | BAGUE TORIQUE      | ANILLO O            | 1,8 X 2 H 2927             | 01  |

| Bld<br>Nr. | Teil-Nr. | Stück-<br>Zahl | Deutsch       | English    | Français           | Español           | Nummer / Bemerkung                                   | ETK |
|------------|----------|----------------|---------------|------------|--------------------|-------------------|--|-----|
| 39         | 233 9680 | 1              | REPARATURSATZ | REPAIR KIT | LOT DE REPARATION  | LOTE REPARACIONES | B347 VOLLSTAENDIG MIT POSIT.<br>12.14-17.29.37-38.41 |     |
| 40         | 233 4457 | 1              | HUELSE        | SLEEVE     | DOUILLE            | CASQUILLO         |  |     |
| 41         | 340 1325 | 1              | DICHTRING     | WASHER     | BAGUE D ETANCHEITE | ANILLO DE JUNTA   | 1952-08-55-28  |     |

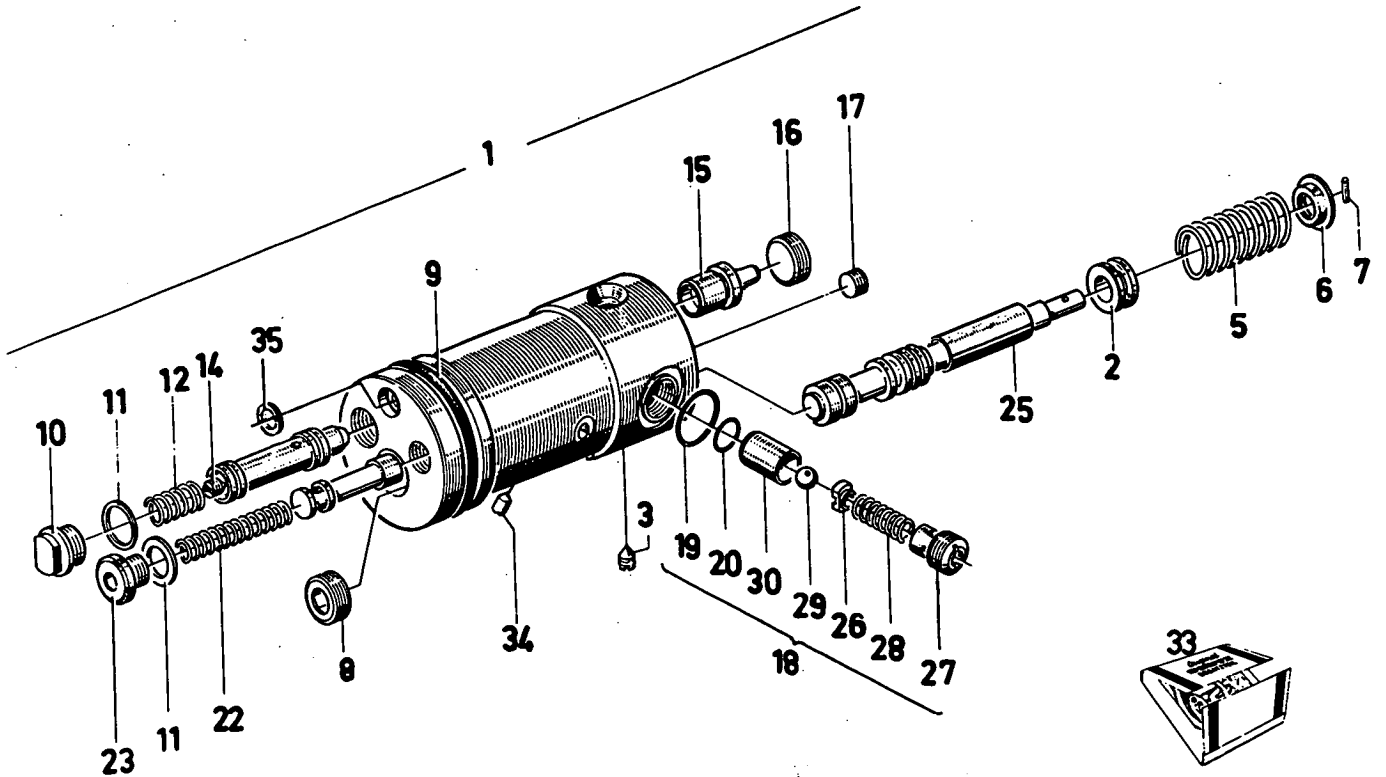

| Bild Nr. | Teil-Nr. | Stück-Zahl | Deutsch            | English            | Français           | Español             | Nummer / Bemerkung          | ETK |
|----------|----------|------------|--------------------|--------------------|--------------------|---------------------|-----------------------------|-----|
| 1        | 237 9661 | 1          | STEUERGERÄT        | CONTROL UNIT       | DISTRIBUTEUR       | APARATO MANDO       |                             |     |
| 2        | 230 0903 | 1          | HALTERING          | RETAINING RING     | BAGUE SUPPORT      | ANILLO SUJECION     |                             |     |
| 3        | 110 8012 | 1          | GEWINDESTIFT       | GRUB SCREW         | GOUPILLE FILETEE   | PERNO ROSCADO       | M 6X 8DIN 553- 5-8          |     |
| 5        | 340 1306 | 1          | SCHRAUBENFEDER     | HELICAL SPRING     | RESSORT A BOUDIN   | RESORTE HELICOIDAL  | 1952-08-42-04               |     |
| 6        | 340 1280 | 1          | FEDERTELLER        | SPRING CAP         | CUVETTE DE RESSORT | PLATO RESORTE       | 1952-08-01-06               |     |
| 7        | 111 5400 | 1          | SPANNHUELSE        | DOWEL SLEEVE       | DOUILLE SERRAGE    | CASQUILLO FIADOR    | 2,5X 12DIN 1461             |     |
| 8        | 110 1024 | 1          | VERSCHLUSSSCHRAUBE | SCREW PLUG         | BOUCHON FILETE     | TAPON ROSCADO       | M18X1,5 DIN 906- 5-8 PHOSPH |     |
| 9        | 116 6080 | 1          | RUNDGUMRING        | O-SEAL             | ANNEAU TORIQUE     | ANILLO GOMA REDOND  | 50 X 4 H 721                | 01  |
| 10       | 230 0899 | 1          | VERSCHLUSSSCHRAUBE | SCREW PLUG         | BOUCHON FILETE     | TAPON ROSCADO       |                             |     |
| 11       | 111 8707 | 2          | DICHTRING          | WASHER             | BAGUE D ETANCHEITE | ANILLO DE JUNTA     | A 16 X 22 DIN 7603-CU       |     |
| 12       | 340 1307 | 1          | SCHRAUBENFEDER     | HELICAL SPRING     | RESSORT A BOUDIN   | RESORTE HELICOIDAL  | 1952-08-42-04               |     |
| 14       | 110 7434 | 1          | GEWINDESTIFT       | GRUB SCREW         | GOUPILLE FILETEE   | PERNO ROSCADO       | M 6X 10DIN 417              |     |
| 15       | 237 4004 | 1          | STOPFEN            | PLUG               | BOUCHON            | TAPON               |                             |     |
| 16       | 230 0897 | 1          | VERSCHLUSSSCHRAUBE | SCREW PLUG         | BOUCHON FILETE     | TAPON ROSCADO       |                             |     |
| 17       | 111 0415 | 1          | VERSCHLUSSSCHRAUBE | SCREW PLUG         | BOUCHON FILETE     | TAPON ROSCADO       | M16X1,5 DIN 906- 5-8        |     |
| 18       | 237 9649 | RS         | RUECKSCHLAGVENTIL  | CHECK VALVE        | SOUPAPE RETENUE    | VALV-DE RETENCION   |                             |     |
| 19       | 117 0485 | 1          | O-RING             | O-SEAL             | BAGUE TORIQUE      | ANILLO O            | 18 X 2 H 2927               | 01  |
| 20       | 230 6576 | 1          | O-RING             | O-SEAL             | BAGUE TORIQUE      | ANILLO O            |                             | 01  |
| 22       | 230 0901 | 1          | DRUCKFEDER         | COMPRESSION SPRING | RESSORT DE COMPR   | RESORTE PRESION     |                             |     |
| 23       | 112 3687 | 1          | VERSCHLUSSSCHRAUBE | SCREW PLUG         | BOUCHON FILETE     | TAPON ROSCADO       | M16X1,5 DIN 908 PHOSPH      |     |
| 25       | 233 4457 | 1          | HUELSE             | SLEEVE             | DOUILLE            | CASQUILLO           |                             |     |
| 26       | 340 1309 | 1          | KUGELSITZ          | BALL SEAT          | SIEGE A ROUTULE    | ASIEN TO BOLA       | 1952-08-42-15               |     |
| 27       | 237 9647 | 1          | GEWINDEHUELSE      | THREADED SLEEVE    | DOUILLE FILETEE    | CASQUILLO ROSCADO   |                             |     |
| 28       | 237 7175 | 1          | DRUCKFEDER         | COMPRESSION SPRING | RESSORT DE COMPR   | RESORTE PRESION     |                             |     |
| 29       | 111 6956 | 1          | KUGEL              | BALL               | BILLE/BOULE        | BOLA                | 8 MM III DIN 5401           |     |
| 30       | 237 6358 | 1          | VENTILSITZ         | VALVE SEAT         | SIEGE DE SOUPAPE   | ASIEN TO DE VALVULA |                             |     |



| Bld<br>Nr. | Teil-Nr. | Stück-<br>Zahl | Deutsch        | English      | Français           | Español           | Nummer/Bemerkung                        | ETK |
|------------|----------|----------------|----------------|--------------|--------------------|-------------------|---|-----|
| 33         | 238 6039 | 1              | REPARATURSATZ  | REPAIR KIT   | LOT DE REPARATION  | LOTE REPARACIONES | BOSO-BESTEHEND AUS POS. 11,<br>18-20-35 | 01  |
| 34         | 238 4642 | 1              | SCHLITZSTOPFEN | SLOTTED PLUG | BOUCHON FENDU      | TAPON RANURADO    |   |     |
| 35         | 340 1325 | 1              | DICHTRING      | WASHER       | BAGUE D ETANCHEITE | ANILLO DE JUNTA   | 1952-08-55-38                           | 01  |

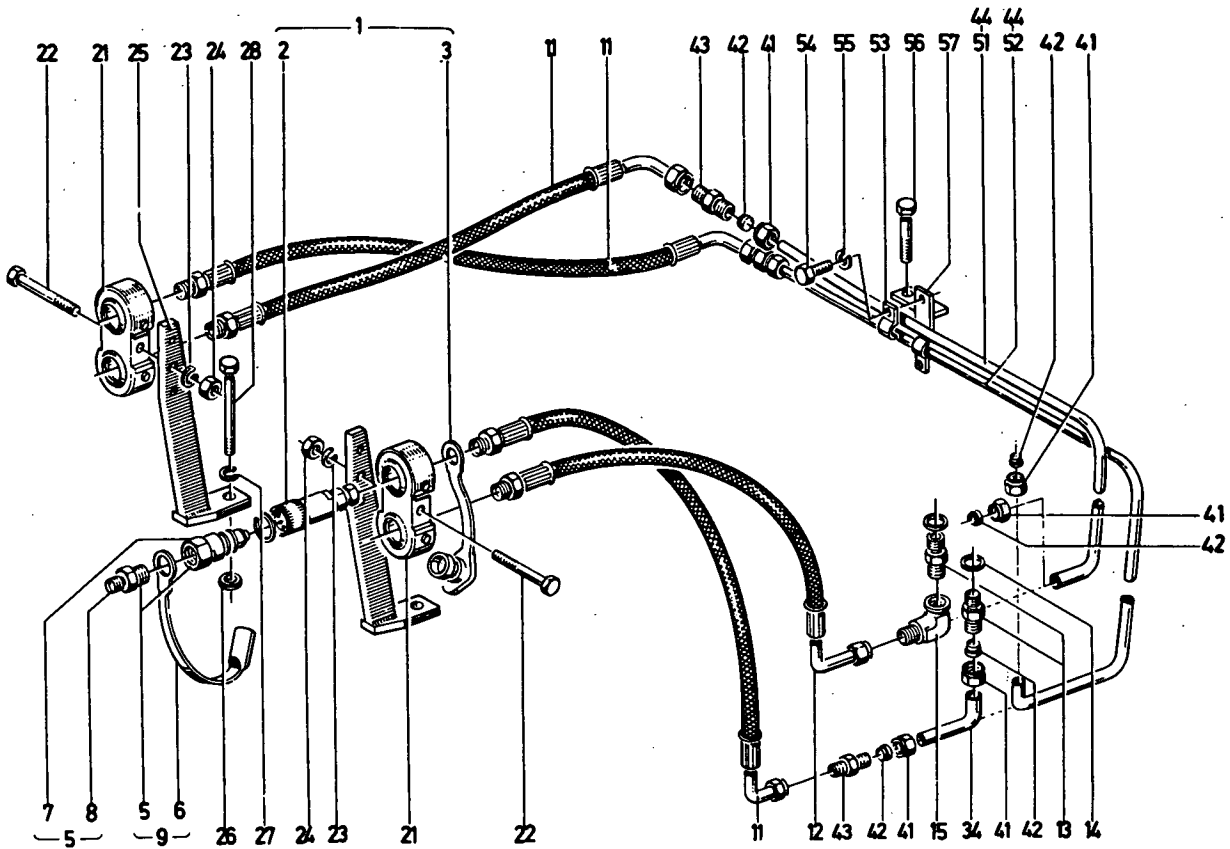

1971-07 500 5151

| Bild Nr. | Teile-Nr. | Stück-Zahl | Deutsch           | English           | Français           | Español            | Nummer/Bemerkung                               | ETK |
|----------|-----------|------------|-------------------|-------------------|--------------------|--------------------|--|-----|
| 1        | 237 0359  | 1          | STECKDOSE         | SOCKET            | PRISE DE COURANT   | CAJA ENCHUFE       | B347-VOLLSTAENDIG MIT POS.2+3                  |     |
| 2        | 231 9777  | 1          | KUPLUNG           | CLUTCH/COUPLING   | ACCOUPL/EMBRAYAGE  | EMBRAGUE/ACOPLE    | 1971-34-27-05                                  |     |
| 3        | 232 1305  | 1          | STECKER           | PLUG              | FICHE DE CONTACT   | CLAVIJA ENCHUFE    | 1941-37-23-03                                  |     |
| 5        | 347 1265  | 1          | STECKER           | PLUG              | FICHE DE CONTACT   | CLAVIJA ENCHUFE    | 1941-37-24-10                                  |     |
| 6        | 231 9366  | 1          | STAUBKAPPE        | DUST CAP          | CAPUCH ANTI-POUSS  | SOMBRES-CONTR.POLV | 1941-37-24-03                                  |     |
| 7        | 231 9364  | 1          | STECKER           | PLUG              | FICHE DE CONTACT   | CLAVIJA ENCHUFE    | 1941-37-24-03                                  |     |
| 8        | 237 3279  | 1          | ADAPTER           | ADAPTER           | RACCORD REDUCTEUR  | ADAPTADOR          |  |     |
| 9        | 231 9363  | 1          | STECKER           | PLUG              | FICHE DE CONTACT   | CLAVIJA ENCHUFE    | 1941-37-24-20<br>B347-VOLLSTAENDIG MIT POS.5+6 |     |
| 11       | 233 4897  | 1          | SCHLAUCHLEITUNG   | HOSE              | CONDUITE FLEXIBLE  | MANGUERA           | B190, 535 MM-LANG                              | 01  |
| 12       | 233 4899  | 1          | SCHLAUCHLEITUNG   | HOSE              | CONDUITE FLEXIBLE  | MANGUERA           | B190, 575MM-LANG                               | 01  |
| 13       | 116 0286  | 1          | EINSCHRAUBSTUTZEN | SCREW-IN NIPPLE   | TUBULURE A VIS     | TUBULAD-ENROSCADA  | M18X1,5X12 H 3132                              |     |
| 14       | 111 8713  | 1          | DICHTRING         | WASHER            | BAGUE D ETANCHEITE | ANILLO DE JUNTA    | A 18 X 22 DIN 7603-CU                          |     |
| 15       | 110 4653  | 1          | WINKELSTUTZEN     | ELBOW             | RACCORD COUDE      | TUBULADURA ANGULAR | L32DIV 3952                                    |     |
| 21       | 231 3039  | 1          | HALTER            | RETAINER          | SUPPORT/PORTEOUTIL | SOPORTE            | B064,00PELT                                    |     |
| 22       | 111 1336  | 1          | SECHSKANTSCHRAUBE | HEX-BOLT          | VIS 6 PANS         | TORNILLO HEXAGONAL | M10X 75 DIN 931- 8-8-A4C                       |     |
| 23       | 110 2800  | 1          | FEDERRING         | SPRING LOCKWASHER | RONDELLE GROUER    | ARANDELA ELASTICA  | A 30 DIN 128 A4C                               |     |
| 24       | 110 2659  | 1          | SECHSKANTMUTTER   | HEX-NUT           | ECROU 6 PANS       | TUERCA HEXAGONAL   | M10 DIN 934-M 8 A4C                            |     |
| 25       | 231 3151  | 1          | HALTER            | RETAINER          | SUPPORT/PORTEOUTIL | SOPORTE            |  |     |
| 26       | 110 7114  | 2          | SCHIEBE           | DISC/PANE/PLATE   | RONDELLE/DISQUE    | DISCO              | A15 DIN 125-ST-A4C                             |     |
| 27       | 110 2802  | 1          | FEDERRING         | SPRING LOCKWASHER | RONDELLE GROUER    | ARANDELA ELASTICA  | A 14 DIN 128 A4C                               |     |
| 28       | 112 4812  | 1          | SECHSKANTSCHRAUBE | HEX-BOLT          | VIS 6 PANS         | TORNILLO HEXAGONAL | M14X 130 DIN 931-M 8-8 A4C                     |     |
| 34       | 231 3157  | 1          | ROHRBOGEN         | PIPE BEND         | COUDE              | CODO DE TUBO       |  |     |
| 41       | 112 2817  | 2          | UEBERWURFMUTTER   | UNION NUT         | ECROU-RACCORD      | TUERCA EMPALME     | AL 120IN 3870 VZKC                             |     |

| Bild<br>Nr. | Teil-Nr. | Stück-<br>Zahl | Deutsch            | English           | Français           | Español            | Nummer/Bemerkung         | UJK |
|-------------|----------|----------------|--------------------|-------------------|--------------------|--------------------|--------------------------|-----|
| 42          | 111 6624 | 2              | SCHNEIDRING        | CUTTING RING      | BAGUE TRCHANTE     | ANILLO CORTANTE    | L 12DIN 3861-ST          |     |
| 43          | 111 6709 | 1              | VERBINDUNGSSTUTZEN | UNION             | RACCORD            | TUBULADURA UNION   | L 12DIN 3902 VZKC        |     |
| 44          | 231 3179 | 1              | ROHR               | PIPE/TUBE         | TUBE/TUYAU         | TUBO               |                          |     |
| 51          | 237 0331 | 1              | ROHR               | PIPE/TUBE         | TUBE/TUYAU         | TUBO               |                          |     |
| 52          | 237 0332 | 1              | ROHR               | PIPE/TUBE         | TUBE/TUYAU         | TUBO               |                          |     |
| 53          | 116 9865 | 1              | ROHRSCHELLE        | PIPE CLIP         | COLLIER PR TUBES   | ABRAZADERA DE TUBO | 2X12H 3202               |     |
| 54          | 111 2232 | 2              | SECHSKANTSCHRAUBE  | HEX-BOLT          | VIS 6 PANS         | TORNILLO HEXAGONAL | M 6X 10 DIN 933- 8-8-A4C |     |
| 55          | 110 2797 | 2              | FEDERRING          | SPRING LOCKWASHER | RONDELLE GROWER    | ARANDELA ELASTICA  | A 6 DIN 128 A4C          |     |
| 56          | 111 1153 | 1              | SECHSKANTSCHRAUBE  | HEX-BOLT          | VIS 6 PANS         | TORNILLO HEXAGONAL | M 8X 45 DIN 931- 8-8-A4C |     |
| 57          | 237 0335 | 1              | HALTER             | RETAINER          | SUPPORT/PORTEOUTIL | SOPORTE            |                          |     |

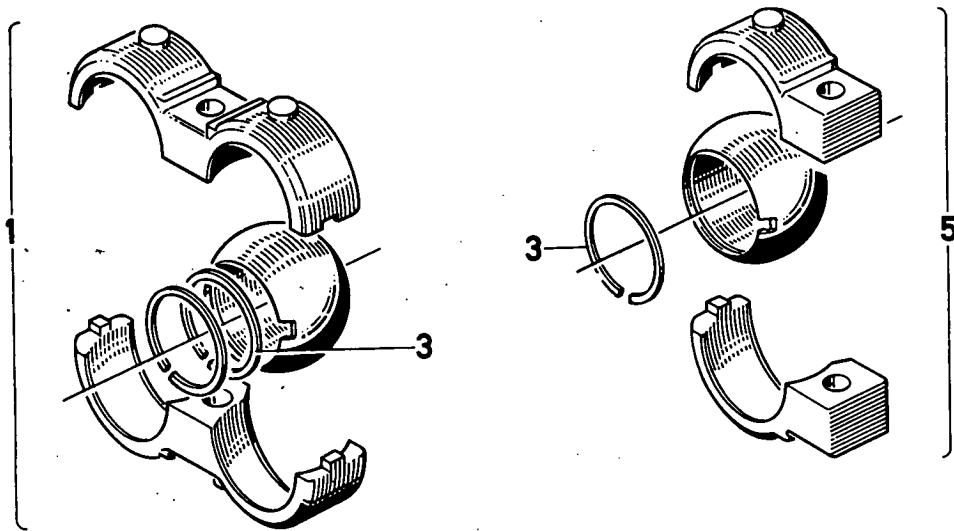

1971-07 500 6124

| Bild Nr. | Teile-Nr. | Stück-Zahl | Deutsch    | English   | Français          | Español          | Nummer/Bemerkung | ETK |
|----------|-----------|------------|------------|-----------|-------------------|------------------|------------------|-----|
| 1        | 231 3039  | 1          | HALTER     | RETAINER  | SUPPORT/PORTEQUIL | SOPORTE          |                  |     |
| 3        | 112 5707  | 2          | SPRENGRING | SNAP RING | AGRAFE CIRCULAIRE | ANILLO RETENCION | 40DIN 9045       |     |
| 5        | 231 3037  | 1          | HALTER     | RETAINER  | SUPPORT/PORTEQUIL | SOPORTE          |                  |     |

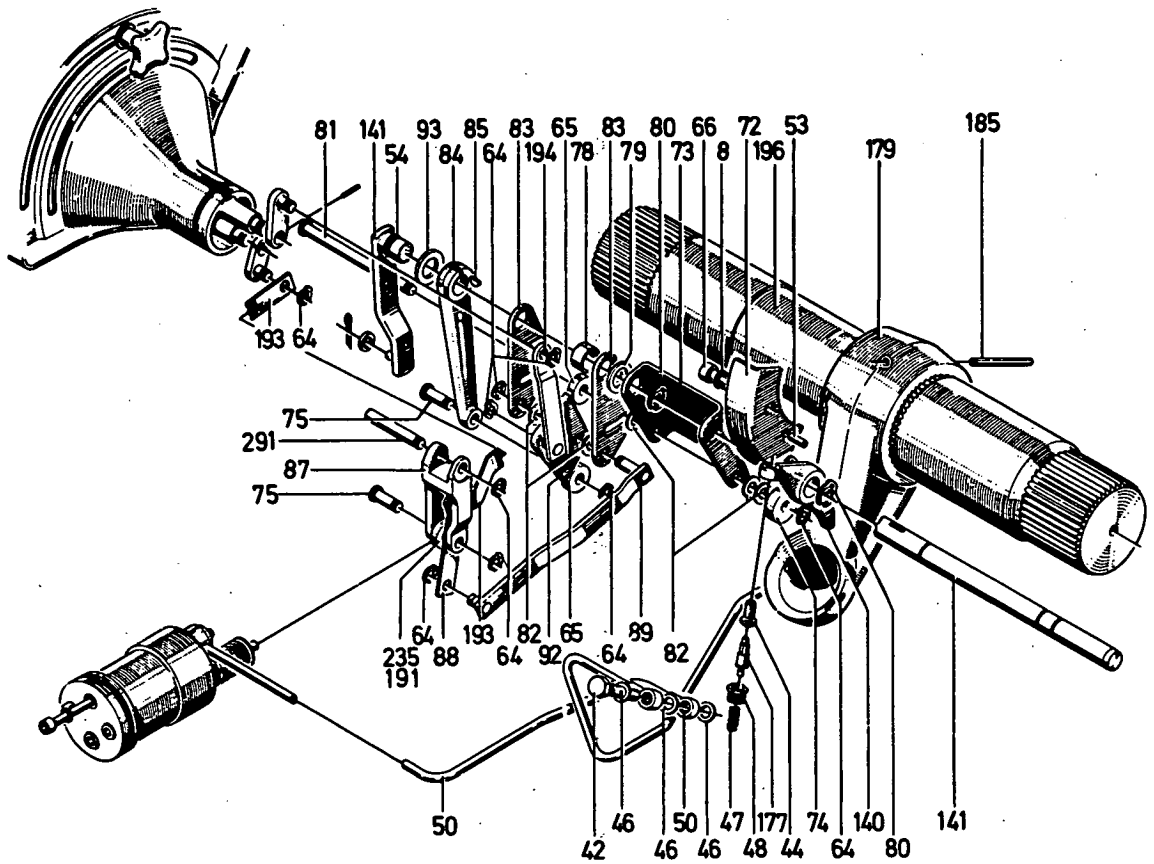
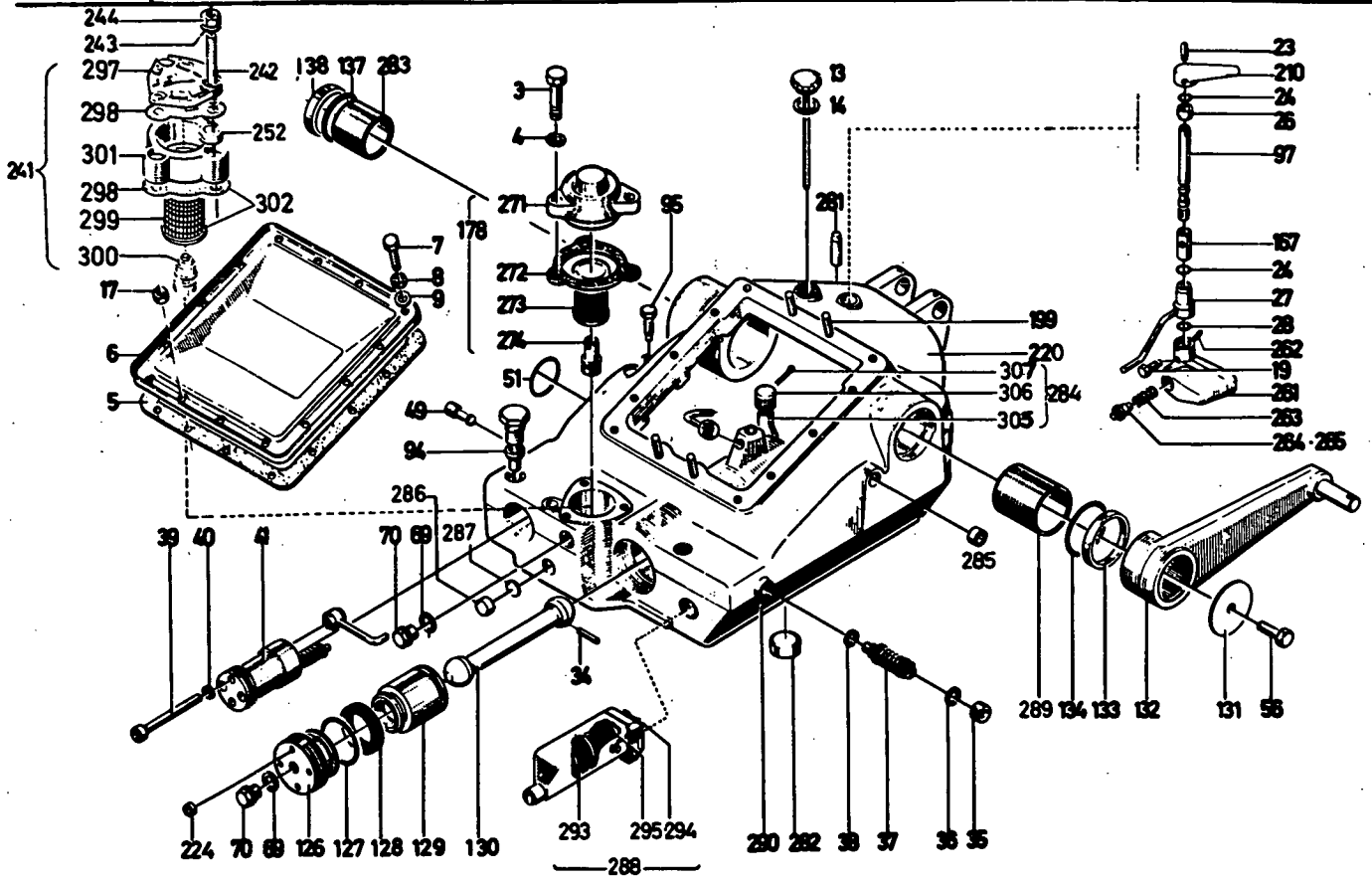

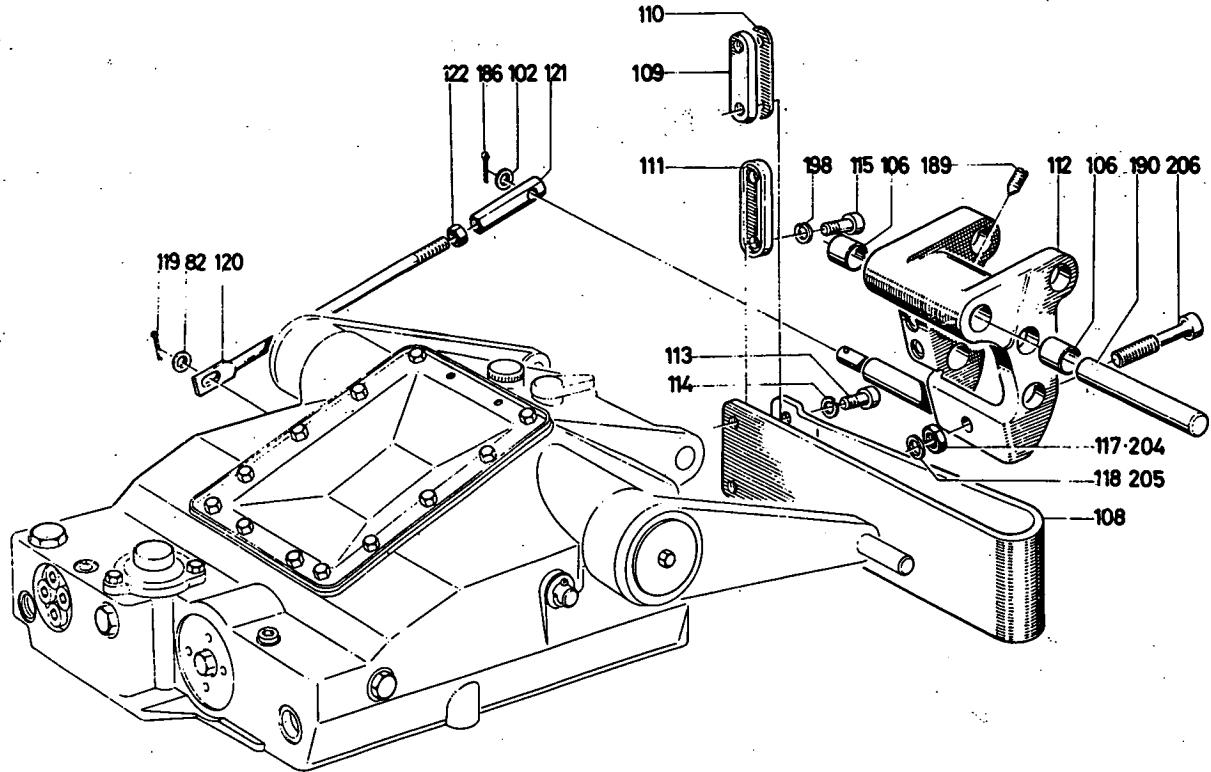

1952-08 500 6240

| Bld Nr. | Teil-Nr. | Stück-Zahl | Deutsch            | English           | Français           | Español            | Nummer/Bemerkung   | ETK |
|---------|----------|------------|--------------------|-------------------|--------------------|--------------------|--|-----|
| 3       | 133 2258 | 3          | SECHSKANTSCHRAUBE  | HEX-BOLT          | VIS 6 PANS         | TORNILLO HEXAGONAL | M 6 X 18 DIN 933- 2-8-A4C<br>8127-FÄHRGESTELL-NO WIE<br>POS. 178 |     |
| 4       | 136 7194 | 3          | SICHERUNGSSCHEIBE  | LOCKING WASHER    | RONDELLE SECURITE  | ARANDELA SEGURIDAD | 6 H 2203<br>8127-FÄHRGESTELL-NO WIE<br>POS. 178                  |     |
| 5       | 340 1287 | 1          | DICHTUNG           | GASKET            | GARNITURE/JOINT    | JUNTA              | 1952-08-41-06  |     |
| 6       | 340 1288 | 1          | DECKEL             | COVER             | COUVERCLE          | TAPA               | 1952-08-41-07  |     |
| 7       | 133 2277 | 10         | SECHSKANTSCHRAUBE  | HEX-BOLT          | VIS 6 PANS         | TORNILLO HEXAGONAL | M 8 X 12 DIN 933- 2-8-A4C  |     |
| 8       | 136 9687 | 15         | SICHERUNGSSCHEIBE  | LOCKING WASHER    | RONDELLE SECURITE  | ARANDELA SEGURIDAD | 8 H 2203   |     |
| 9       | 130 7548 | 18         | SCHLEIFE           | DISC/PANE/PLATE   | RONDELLE/DISQUE    | DISCO              | 8-4DIN 433-ST-A4C  |     |
| 13      | 230 6604 | 1          | ÖLMESSSTAB         | OIL DIPSTICK      | JAUGE D HUILE      | VARIL-NIVEL ACEITE |  |     |
| 14      | 238 0742 | 1          | DICHTRING          | WASHER            | BAGUE D ETANCHEITE | ANILLO DE JUNTA    |  |     |
| 17      | 133 2824 | 4          | SECHSKANTMUTTER    | HEX-NUT           | ECROU 6 PANS       | TUERCA HEXAGONAL   | M 8 DIN 934-M 2 A4C  |     |
| 19      | 130 8137 | 1          | ZAPFENSCHRAUBE     | SPIGOT SCREW      | VIS A TETON        | TORNILLO ESPIGA    | AM 8X 20 DIN 561- 5-8  |     |
| 23      | 133 5440 | 1          | SPANNHUELSE        | DOWEL SLEEVE      | DOUILLE SERRAGE    | CASQUILLO FIADOR   | 5 X 32DIN 1481   |     |
| 24      | 136 0037 | 2          | O-RING             | O-SEAL            | BAGUE TORIQUE      | ANILLO O           | 36 X 2 H 2927-61 DEUTZ 9   | 01  |
| 26      | 340 1320 | 1          | BUCHSE             | BUSH              | DOUILLE            | CASQUILLO          | 1952-08-55-24  |     |
| 27      | 230 6525 | 1          | BUCHSE             | BUSH              | DOUILLE            | CASQUILLO          |  |     |
| 28      | 136 0044 | 1          | O-RING             | O-SEAL            | BAGUE TORIQUE      | ANILLO O           | 30 X 2 H 2927-61 DEUTZ 6   | 01  |
| 34      | 132 3860 | 1          | SPANNHUELSE        | DOWEL SLEEVE      | DOUILLE SERRAGE    | CASQUILLO FIADOR   | 5 X 70DIN 1481   |     |
| 35      | 132 4760 | 1          | VERSCHLUSSSCHRAUBE | SCREW PLUG        | BOUCHON FILETE     | TAPON ROSCADO      | M26X1,5 DIN 908  |     |
| 36      | 133 8760 | 1          | DICHTRING          | WASHER            | BAGUE D ETANCHEITE | ANILLO DE JUNTA    | A 26 X 31 DIN 7603-CU  |     |
| 37      | 340 0830 | 1          | SICHERHEITSVENTIL  | SAFETY VALVE      | SOUPAPE SECURITE   | VALVULA SEGURIDAD  | 1941-08-26-10  |     |
| 38      | 133 8688 | 1          | DICHTRING          | WASHER            | BAGUE D ETANCHEITE | ANILLO DE JUNTA    | A 14 X 18 DIN 7603-CU  |     |
| 39      | 133 0634 | 1          | ZYLINDERSCHRAUBE   | CHEESE-HEAD SCREW | VIS TETE CYLINDR.  | TORN-CB2A-CILINDR. | M 8 X 120DIN 912- 2-8  |     |
| 40      | 340 1325 | 1          | DICHTRING          | WASHER            | BAGUE D ETANCHEITE | ANILLO DE JUNTA    | 1952-08-55-38  | 01  |
| 43      | 230 0706 | 1          | REGELSTEUERGERAET  | MAIN CONTROL UNIT | DISTRIBUTEUR PRINC | APTO-MANDO REGULAD | 8313-TEILENUMMER-LISTENBLATT<br>1952-06 500 5132                 |     |

| Bld Nr. | Tele-Nr. | Stück-Zahl | Deutsch            | English            | Français           | Español             | Nummer/Bemerkung          | ETK |
|---------|----------|------------|--------------------|--------------------|--------------------|---------------------|---------------------------|-----|
| 42      | 331 5353 | 1          | DOPPELFOHLSCHRAUBE | BANJO BOLT         | VIS BANJO DOUBLE   | TORN-RACOR DOBLE    |                           |     |
| 44      | 340 1327 | 1          | STELLSCHRAUBE      | SET SCREW          | VIS DE REGLAGE     | TORNILLO GRADUAC.   | 1952-08-55-43             |     |
| 46      | 111 8659 | 3          | DICHRING           | WASHER             | BAGUE D ETANCHEITE | ANILLO DE JUNTA     | A 10 X 13,5DIN 7603-CU    |     |
| 47      | 340 1282 | 1          | DRUCKFEDER         | COMPRESSION SPRING | RESSORT DE COMPR   | RESORTE PRESSION    | 1952-08-11-46             |     |
| 48      | 230 1251 | 1          | VENTILSITZ         | VALVE SEAT         | SIEGE DE SOUPAPE   | ASIENITO DE VALVULA |                           |     |
| 49      | 340 1297 | 1          | HUELSE             | SLEEVE             | DOUILLE            | CASQUILLO           | 1952-08-41-56             |     |
| 50      | 233 5240 | 1          | STEUERLEITUNG      | CONTROL PIPE       | COND-HUILE-PILOTE  | TUBERIA DE MANDO    |                           |     |
| 51      | 116 6059 | 1          | RUNDGUMPHRING      | O-SEAL             | ANNEAU TORIQUE     | ANILLO GOMA REDOND  | 40 X 3 H 721              | 01  |
| 53      | 111 5433 | 1          | SPANNHUELSE        | DOWEL SLEEVE       | DOUILLE SERRAGE    | CASQUILLO FIADOR    | 5 X 16DIN 1481            |     |
| 54      | 116 0038 | 1          | O-RING             | O-SEAL             | BAGUE TORIQUE      | ANILLO C            | 10 X 3 H 2927-CI BELTZ 9  | 01  |
| 56      | 111 2305 | 2          | SECHSKANTSCHRAUBE  | HEX-BOLT           | VIS 6 PANS         | TORNILLO HEXAGONAL  | M 2X 15-DIN 932- 2-2-ANC  |     |
| 64      | 340 1328 | 9          | SICHERUNG          | FUSE/LOCK          | FUSIBLE/COUPE-CIRC | SEGURO/FUSIBLE      | 1952-08-55-66             |     |
| 65      | 340 1378 | 2          | ROLLE              | ROLLER             | ROULEAU/GALET      | RODILLO/POLEA       | 1952-08-78-03             |     |
| 66      | 111 0550 | 1          | ZYLINDERSCHRAUBE   | CHEESE-HEAD SCREW  | VIS TETE CYLINDR.  | TORN-CB7A-CILIND.   | M 2X 15DIN 932- 6-9       |     |
| 69      | 111 8713 | 2          | DICHRING           | WASHER             | BAGUE D ETANCHEITE | ANILLO DE JUNTA     | A 16 X 22 DIN 7603-CU     |     |
| 70      | 111 8971 | 2          | VERSCHLUSSSCHRAUBE | SCREW PLUG         | BOUCHON FILETE     | TAPON ROSCADO       | M18X1,5 DIN 7604 VZKC     |     |
| 72      | 340 1400 | 1          | SEGMENT            | QUADRANT/SEGMENT   | SEGMENT/SECTEUR    | SEGMENTC            | 1952-08-95-62             |     |
| 73      | 340 1401 | 1          | LAGENHELDER        | POS N TRANSMITTER  | INDICATEUR POSIT.  | INDICADOR POSICION  | 1952-08-95-63             |     |
| 74      | 231 9764 | 1          | ROLLE              | ROLLER             | ROULEAU/GALET      | RODILLO/POLEA       | 1952-08-78-20             |     |
| 75      | 340 1402 | 2          | BOLZEN             | PIN/BOLT/STUD      | BOULON/AXE         | BULON               | 1952-08-95-64             |     |
| 78      | 340 1404 | 1          | ABSTANDBUCHSE      | SPACER BUSH        | DOUILLE ECARTEN    | CASQ-DISTANCIARIO   | 1952-08-95-69             |     |
| 79      | 110 7557 | 1          | SCHLEIBE           | DISC/PANE/PLATE    | RONDILLE/DISQUE    | DISCO               | 17 DIN 433-ST             |     |
| 80      | 340 1405 | 3          | SICHERUNG          | FUSE/LOCK          | FUSIBLE/COUPE-CIRC | SEGURO/FUSIBLE      | 1952-08-95-71             |     |
| 81      | 340 1406 | 1          | BOLZEN             | PIN/BOLT/STUD      | BOULON/AXE         | BULON               | 1952-08-95-72             |     |
| 82      | 110 7098 | 6          | SCHLEIBE           | DISC/PANE/PLATE    | RONDILLE/DISQUE    | DISCO               | 8,4DIN 125                |     |
| 83      | 340 1407 | 2          | LASCHE             | CONNECTING PLATE   | ECLISSE            | ECLISA              | 1952-08-95-73             |     |
| 84      | 340 1408 | 1          | HEBEL              | LEVER/ARM          | LEVIER             | PALANCA             | 1952-08-95-74             |     |
| 85      | 111 8323 | 1          | SCHLEIBENFEDER     | WOODRUFF KEY       | CLAVETTE WOODRUFF  | CHAVETA MEDIA LUNA  | 3 X 5 DIN 6888            |     |
| 87      | 340 1390 | 1          | SCHWINGE           | SHACKLE            | BALANCIER          | BALANCIER/PLUMA     | 1952-08-95-128            |     |
| 88      | 340 1391 | 1          | HEBEL              | LEVER/ARM          | LEVIER             | PALANCA             | 1952-08-95-129            |     |
| 89      | 340 1421 | 1          | STANGE             | ROD/BAR            | BARRE/TIGE/TRINGLE | BARRA/VARILLA       | 1952-08-113-30            |     |
| 92      | 340 1409 | 1          | SCHALTKULISSE      | SHIFT GATE         | COULISSE           | PLACA GUIA CAMBIO   | 1952-08-97-02             |     |
| 93      | 232 0492 | 1          | RING               | RING               | BAGUE/ANNEAU       | ANILLO              | 1952-08-114-30            |     |
| 94      | 340 1392 | 1          | PATRONE            | CARTRIDGE          | CARTOUCHE          | CARTUCC             | 1952-08-85-136            |     |
| 95      | 112 6091 | 1          | SECHSKANTSCHRAUBE  | HEX-BOLT           | VIS 6 PANS         | TORNILLO HEXAGONAL  | M 2X 35 DIN 561- 5-8 VZKC |     |
| 97      | 230 6574 | 1          | WELLE              | SHAFT              | ARBRE              | EJE/ARBOL           |                           |     |
| 102     | 110 7105 | 1          | SCHLEIBE           | DISC/PANE/PLATE    | RONDILLE/DISQUE    | DISCO               | A10,5DIN 125-ST-ANC       |     |
| 106     | 231 2166 | 2          | BUCHSE             | BUSH               | DOUILLE            | CASQUILLO           |                           |     |
| 108     | 340 0133 | 1          | FEDER              | SPRING             | RESSORT            | RESORTE/BALLESTA    |                           |     |
| 109     | 340 0134 | 1          | LASCHE             | CONNECTING PLATE   | ECLISSE            | ECLISA              | 1925-08-11-73             |     |
| 110     | 340 0143 | 1          | BEILAGE            | SHIM               | CALE               | SUPLEMENTO          | 1925-08-11-114            |     |
| 111     | 340 0135 | 1          | LASCHE             | CONNECTING PLATE   | ECLISSE            | ECLISA              | 1925-08-11-74             |     |
| 112     | 233 1345 | 1          | GEBERSCHWINGE      | ROCKER             | CHAPE OSCILLANTE   | BALANCIER TRANSPIE. |                           |     |
| 113     | 111 0782 | 2          | ZYLINDERSCHRAUBE   | CHEESE-HEAD SCREW  | VIS TETE CYLINDR.  | TORN-CB7A-CILIND.   | M12X 70DIN 932-10-9       |     |
| 114     | 111 9615 | 2          | FEDERRING          | SPRING LOCKWASHER  | RONDILLE GROUER    | ARANDELA ELASTICA   | 12DIN 7990 VZKC           |     |
| 115     | 111 0764 | 2          | ZYLINDERSCHRAUBE   | CHEESE-HEAD SCREW  | VIS TETE CYLINDR.  | TORN-CB7A-CILIND.   | M12X 40DIN 932-10-9 ANC   |     |
| 117     | 111 2858 | 1          | SECHSKANTMUTTER    | HEX-NUT            | ECROU 6 PANS       | TUERCA HEXAGONAL    | M12 DIN 934-M 2 ANC       |     |
| 118     | 340 0162 | 1          | SCHLEIBE           | DISC/PANE/PLATE    | RONDILLE/DISQUE    | DISCO               | 1925-08-17-10             |     |
| 119     | 110 6407 | 1          | SPLINT             | SPLIT PIN          | GOUPILLE FENDUE    | PASADOR ALETAS      | 2 X 15DIN 94-ANC          |     |
| 120     | 232 6790 | 1          | VERSTELLSTANGE     | ADJUSTING ROD      | TRINGLE DE REGLAGE | BARRA GRADUAC.      |                           |     |
| 121     | 340 1303 | 1          | EINSTELLMUTTER     | ADJUSTING NUT      | ECROU DE REGLAGE   | TUERCA GRADUAC.     | 1952-08-41-102            |     |
| 122     | 111 2852 | 1          | SECHSKANTMUTTER    | HEX-NUT            | ECROU 6 PANS       | TUERCA HEXAGONAL    | M10 X1 DIN 934-M 2 ANC    |     |

| Bld Nr. | Teil-Nr. | Stück-Zahl | Deutsch            | English            | Français           | Español            | Nummer/Bemerkung  | ETK |
|---------|----------|------------|--------------------|--------------------|--------------------|--------------------|---|-----|
| 126     | 347 1298 | 1          | STOPFEN            | PLUG               | BOUCHON            | TAPON              | 1952-08-95-38   |     |
| 127     | 116 1641 | 1          | O-RING             | O-SEAL             | BAGUE TORIQUE      | ANILLO O           | 64 X 3 H 2927-01 DEUTZ 6  | 01  |
| 128     | 347 1299 | 1          | NUTRING            | V-SEAL             | BAGUE RAINUREE     | ANILLO FANURADO    | 1952-08-95-43   | 01  |
| 129     | 347 4299 | 1          | KOLBEN             | PISTON/PLUNGER     | PISTON             | EMBOLO/PISTON      | 1952-08-95-44   |     |
| 130     | 347 1301 | 1          | PLEUEL             | CONNECTING-ROD     | BIELLE             | BIELA              | 1952-08-95-45   |     |
| 131     | 347 1303 | 2          | SCHEIBE            | DISC/PANE/PLATE    | RONDELLE/DISQUE    | DISCO              | 1952-08-95-76   |     |
| 132     | 347 5234 | 2          | HEBEARM            | LIFT ARM           | BRAS DE LEVAGE     | BRAZO ELEVAC.      | 1952-08-103-30  |     |
| 133     | 347 1304 | 1          | RING               | RING               | BAGUE/ANNEAU       | ANILLO             | 1952-08-95-78   |     |
| 134     | 231 2185 | 1          | DICHTRING          | WASHER             | BAGUE D ETANCHEITE | ANILLO DE JUNTA    |   | 01  |
| 137     | 231 2186 | 1          | DICHTRING          | WASHER             | BAGUE D ETANCHEITE | ANILLO DE JUNTA    |   | 01  |
| 138     | 347 1307 | 1          | RING               | RING               | BAGUE/ANNEAU       | ANILLO             | 1952-08-95-84   |     |
| 140     | 340 1326 | 1          | KIPPHEEL           | ROCKER ARM         | CULBUTEUR          | BALANCIER          | 1952-08-55-92   |     |
| 141     | 231 4739 | 1          | WELLE              | SHAFT              | ARBRE              | EJE/ARBOL          | 1952-08-101-30  |     |
| 167     | 230 6602 | 1          | ABSTANIBUCHSE      | SPACER BUSH        | DOUILLE ECARTEN    | CASO-DISTANCIARIO  |   |     |
| 177     | 230 1250 | 1          | VENTIL             | VALVE              | SOUPAPE/ROBINET    | VALVULA            |   |     |
| 178     | 231 1984 | 1          | EINBAUFILTER       | INLET STRAINER     | FILTRE INCORP.     | FILTRO INCORPORAC. | 8027-BIS FAHRGESTELL-NR.<br>02506, 7535/2742<br>03006, 7488/435C<br>04006, 7879/1434<br>04506, 7876/5002, 7868/322<br>8004, AB FAHRGESTELL-NO.<br>POS. 241  |     |
| 179     | 231 2039 | 1          | HEBEL              | LEVER/ARM          | LEVIER             | PALANCA            |   |     |
| 185     | 111 5479 | 1          | SPANNHELSE         | DOVEL SLEEVE       | DOUILLE SERRAGE    | CASQUILLO FIADOR   | 8 X 55DIN 1481  |     |
| 186     | 110 6435 | 1          | SPLINT             | SPLIT PIN          | GOUPILLE FENDUE    | PASADOR ALETAS     | 3 X 25DIN 94-A4C  |     |
| 189     | 231 4780 | 1          | GEWINDESTIFT       | GRUB SCREW         | GOUPILLE FILETEE   | PERNO RESCADO      |   |     |
| 190     | 110 2335 | 1          | BOLZEN             | PIN/BOLT/STUD      | BOULON/AXE         | BULON              | 25H11X135 DIN 1433-MS150-2K   |     |
| 191     | 347 1292 | 1          | ROLLE              | ROLLER             | ROULEAU/GALET      | RODILLO/POLEA      | 1952-08-78-05   |     |
| 193     | 231 4874 | 1          | STANGE             | ROD/BAR            | BARRE/TIGE/TRINGLE | BARRA/VARILLA      |   |     |
| 194     | 231 4872 | 1          | ZUGSTANGE          | PULLROD            | TIRANT             | BARRA TRACCION     |   |     |
| 196     | 231 2040 | 1          | WELLE              | SHAFT              | ARBRE              | EJE/ARBOL          |   |     |
| 198     | 110 2801 | 2          | FEDERRING          | SPRING LOCKWASHER  | RONDELLE GROBER    | ARANDELA ELASTICA  | A 12 DIN 128 A4C  |     |
| 199     | 111 3389 | 4          | STIFTSCHRAUBE      | STUD               | GOUJON             | ESPARRAGO          | M 8 X 25 DIN 934- 6.8-A4C   |     |
| 204     | 111 3152 | 1          | SECHSKANTSCHRAUBE  | HEX.BOLT           | VIS 6 PANS         | TORNILLO HEXAGONAL | M12 DIN 936-MS5-A4C   |     |
| 205     | 110 7110 | 1          | SCHEIBE            | DISC/PANE/PLATE    | RONDELLE/DISQUE    | DISCO              | A13 DIN 125-ST-A4C  |     |
| 206     | 233 1564 | 1          | STELLSCHRAUBE      | SET SCREW          | VIS DE REGLAGE     | TORNILLO GRADUAC.  |   |     |
| 210     | 233 1817 | 1          | GRIFP              | HANDLE             | POIGNEE/MANETTE    | PUNO/AASA          |   |     |
| 220     | 233 5258 | 1          | KRAFTHEBERGEMAEUSE | LIFT HOUSING       | CORPS VERIN HYDRAU | BLOQUE ELEV-HIDR.  |   |     |
| 224     | 116 7311 | 4          | VERSCHLUSSSTOPFEN  | NIPPLE             | BOUCHON            | TAPON OETURADOR    | A 9 H 2873  |     |
| 235     | 347 1291 | 1          | ROLLE              | ROLLER             | ROULEAU/GALET      | RODILLO/POLEA      | 1952-08-78-04   |     |
| 241     | 237 5478 |            | OELBADFILTER       | BATH AIR CLEANER   | EPURAT BAIN HUILE  | FILT-BAND ACEITE   | 8004, AB FAHRGESTELL-NO<br>02506, 7535/1742,<br>03006, 7488/4351,<br>04006, 7879/1433,<br>04506, 7876/5004, 7868/323<br>8027-BIS FAHRGESTELL-NO<br>POS. 178 |     |
| 242     | 237 7480 | 3          | STIFTSCHRAUBE      | STUD               | GOUJON             | ESPARRAGO          |   |     |
| 243     | 110 7279 | 3          | FEDERSCHEIBE       | SPRING WASHER      | RONDELLE ELASTIQUE | ARANDELA ELASTICA  | B 6 DIN 137   |     |
| 244     | 111 2813 | 3          | SECHSKANTMUTTER    | HEX.NUT            | ECROU 6 PANS       | TUERCA HEXAGONAL   | M 6 DIN 934-M 2 A4C   |     |
| 252     | 110 7955 | 3          | SCHLITZMUTTER      | SLOTTED NUT        | ECROU FENDU        | TUERCA FANUPADA    | M 6 DIN 546- 6  |     |
| 261     | 237 7200 | 1          | RIEGEL             | LATCH/CATCH        | VERROU             | CERROJO            |   |     |
| 262     | 110 7969 | 1          | GEWINDESTIFT       | GRUB SCREW         | GOUPILLE FILETEE   | PERNO RESCADO      | M 6 X 6DIN 551- 5-2   |     |
| 263     | 340 1282 | 1          | DRUCKFEDER         | COMPRESSION SPRING | RESSORT DE COMPR   | RESORTE PRESTICK   | 1952-08-11-46   | 01  |
| 264     | 230 1251 | 1          | VENTILSITZ         | VALVE SEAT         | SIEGE DE SOUPAPE   | ASIENTO DE VALVULA |   |     |
| 265     | 230 1250 | 1          | VENTIL             | VALVE              | SOUPAPE/ROBINET    | VALVULA            |   |     |



| Bld Nr. | Teil-Nr. | Stück-Zahl | Deutsch            | English          | Français           | Español            | Nummer/Bemerkung  | ETK |
|---------|----------|------------|--------------------|------------------|--------------------|--------------------|---|-----|
| 271     | 231 1985 | 1          | FILTERBECKEL       | COVER            | COUVERCLE DE FILTR | TAPA FILTRO        |   |     |
| 272     | 231 1986 | 1          | DICHTUNG           | GASKET           | GARNITURE/JOINT    | JUNTA              |   | 01  |
| 273     | 231 1975 | 1          | PAPIERFATRONE      | PAPER CARTRIDGE  | CARTOUCHE PAPIER   | CARTUCHO PAPEL     |   | 01  |
| 274     | 231 1987 | 1          | VENTIL             | VALVE            | SOUPAPE/ROBINET    | VALVULA            |   |     |
| 281     | 340 1321 | 1          | STIFT              | PIN              | CHEVILLE/GOUPILLE  | PERNO/PASADOR      | 1952-08-55-29   |     |
| 282     | 116 5842 | 1          | KERNLOCHVERSCHLUSS | CORE HOLE PLUG   | BOUCHON TROU DESS  | CIERRE PACHO       | 860 H 711   |     |
| 283     | 347 1305 | 1          | LAGERBUCHSE        | BEARING BUSH     | BAGUE DE PALIER    | CASQU-COJINETE     | 1952-08-95-81   |     |
| 284     | 230 6597 | 1          | ENTLUEFTUNGSROHR   | BREATHER PIPE    | TUBE DE DESAERAGE  | TUBO PRE-AIRE      |   |     |
| 285     | 116 5827 | 1          | KERNLOCHVERSCHLUSS | CORE HOLE PLUG   | BOUCHON TROU DESS  | CIERRE PACHO       | 818 H 711   |     |
| 286     | 116 2041 | 1          | STOPFEN            | PLUG             | BOUCHON            | TAPON              | A 17 H 2955   |     |
| 287     | 116 7017 | 1          | SCHIEBE            | DISC/PANE/PLATE  | RONDELLE/DISQUE    | DISCO              | A 16 X 2 H 984<br>8347-VOLLSTAENIG MIT POS.<br>251-254- |     |
| 288     | 232 0098 | 1          | SAUGFILTER         | INTAKE FILTER    | FILTRE ASPIRAT     | FILTRO ASPIRACION  |   |     |
| 289     | 347 1306 | 1          | LAGERBUCHSE        | BEARING BUSH     | BAGUE DE PALIER    | CASQU-COJINETE     | 1952-08-95-82   |     |
| 290     | 233 4468 | 1          | KRAFTHEBERGEHAEUSE | LIFT HOUSING     | CORPS VERIN HYDRAU | BLOQUE ELEV.HYDR.  |   |     |
| 291     | 233 1959 | 1          | BOLZEN             | PIN/BOLT/STUD    | BOULON/AXE         | BULON              |   |     |
| 293     | 232 0095 | 1          | SIEBEINSATZ        | STRAINER         | ELEMENT TAMISANT   | ELEMENTO TAMIZ     |   | 01  |
| 294     | 232 0096 | 1          | FEDERBUEGEL        | SPRING CLAMP     | ETRIER DE RESSORT  | ESTRIBO RESORTE    |   |     |
| 295     | 233 1567 | 1          | O-RING             | O-SEAL           | BAGUE TORIQUE      | ANILLO O           |   | 01  |
| 297     | 237 9114 | 1          | FILTERBECKEL       | COVER            | COUVERCLE DE FILTR | TAPA FILTRO        |   |     |
| 298     | 237 5476 | 2          | DICHTUNG           | GASKET           | GARNITURE/JOINT    | JUNTA              |   | 01  |
| 299     | 237 1583 | 1          | PATRONE            | CARTRIDGE        | CARTOUCHE          | CARTUCHO           |   | 01  |
| 300     | 237 5479 | 1          | VENTIL             | VALVE            | SOUPAPE/ROBINET    | VALVULA            |   |     |
| 301     | 237 1122 | 1          | ABSTANBRING        | SPACER RING      | BAGUE ECARTEMENT   | ARO DISTANCIARIO   |   |     |
| 302     | 238 0014 | SZ         | WECHSELFILTER      | FILTER CARTRIDGE | CARTOUCHE CONSOMM- | FILTRO SUSTITUCION |   | 01  |
| 305     | 230 6581 | 1          | ENTLUEFTUNGSROHR   | BREATHER PIPE    | TUBE DE DESAERAGE  | TUBO PRE-AIRE      |   |     |
| 306     | 340 0021 | 1          | SCHNUEFFELVENTIL   | SNIFTING VALVE   | RENIFLARD          | VALVULA RONCABORA  | 1925-01-02-05   |     |
| 307     | 110 6398 | 1          | SPLINT             | SPLIT PIN        | GOUPILLE FENDUE    | PASADOR ALETAS     | 1.5X 30DIN 94   |     |



KRAFTHEBERANLAGE  
HYDRAULIC SYSTEM  
RELEVAGE HYDRAULIQUE DTS  
SISTEMA DE ELEVADOR HIDRAULICO

1952-08 502 0153

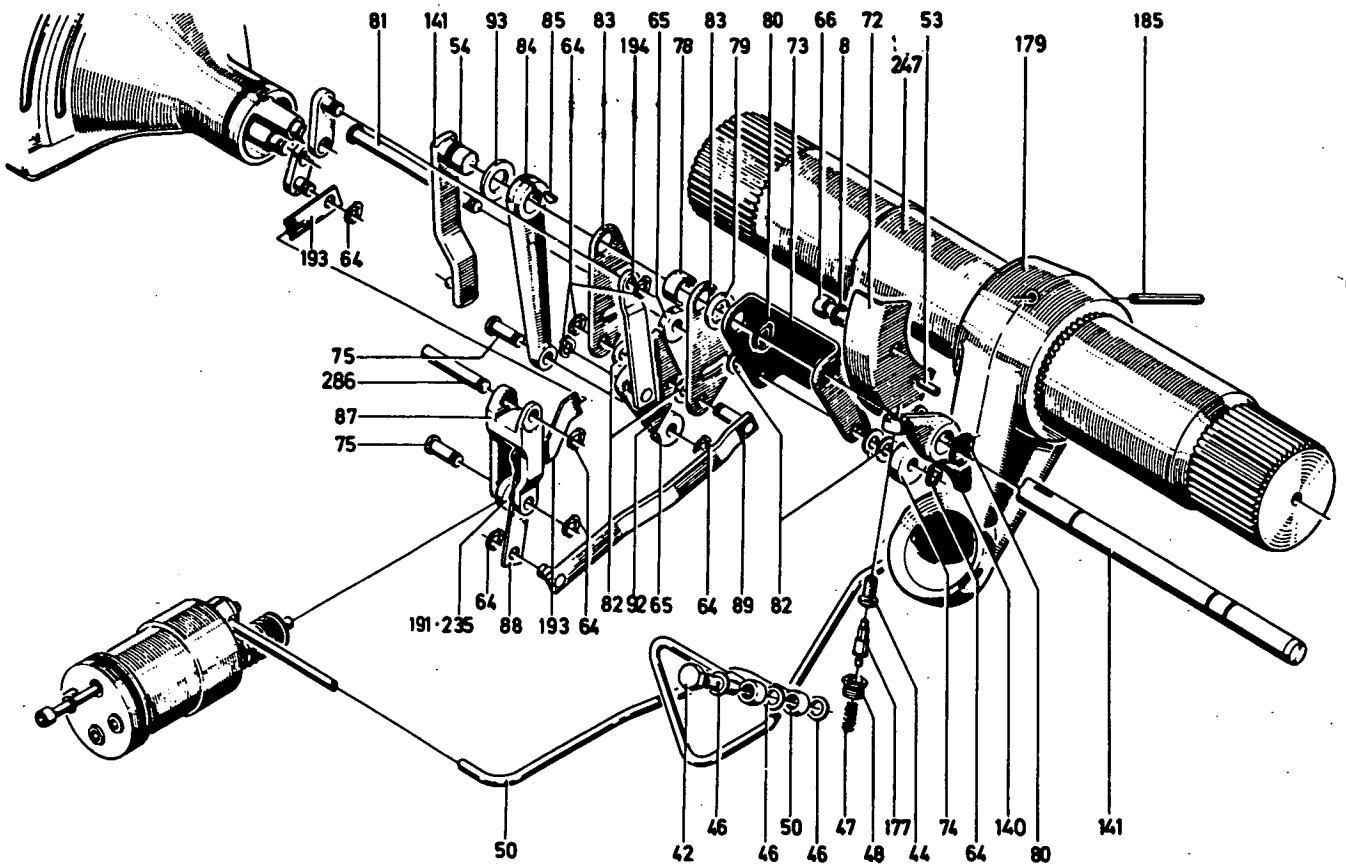
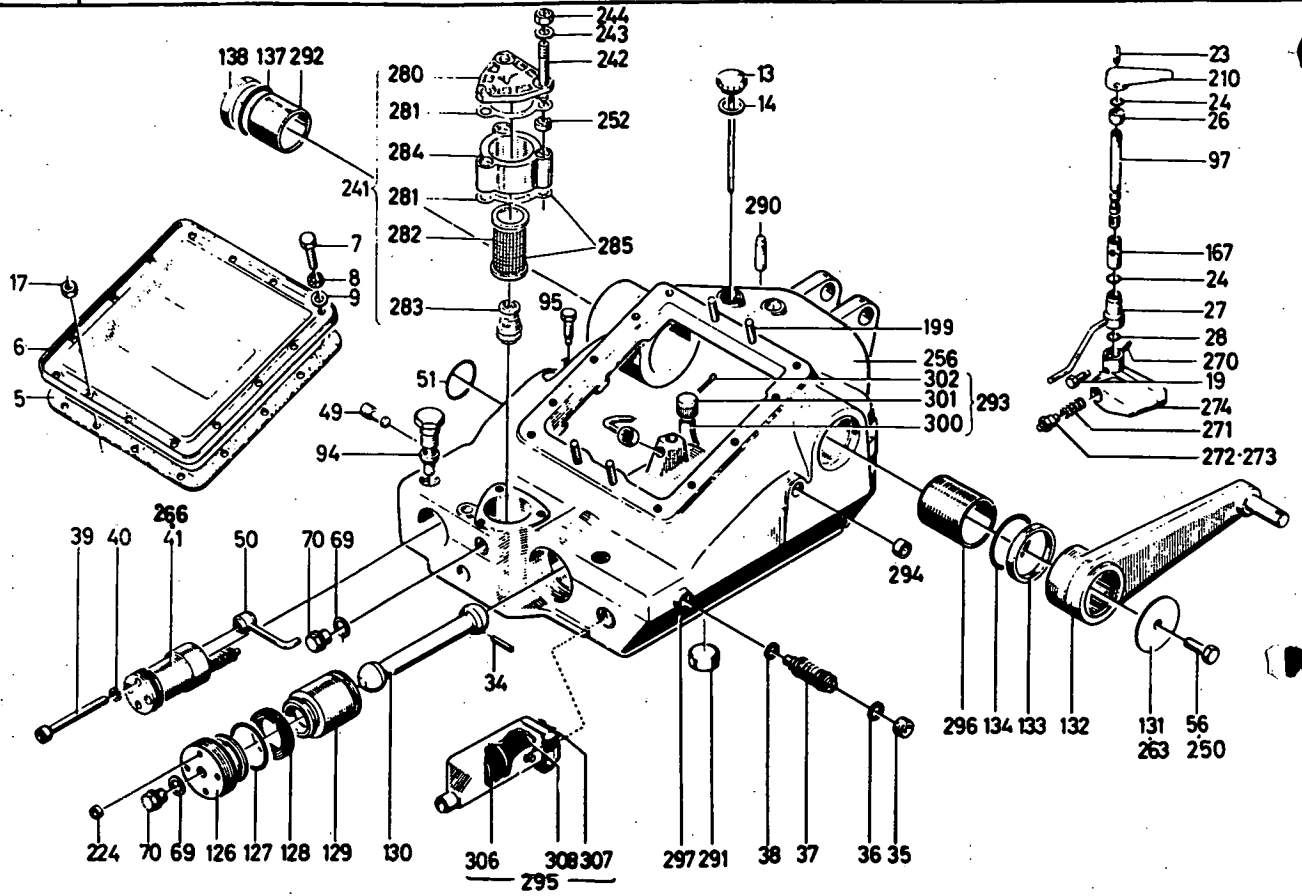

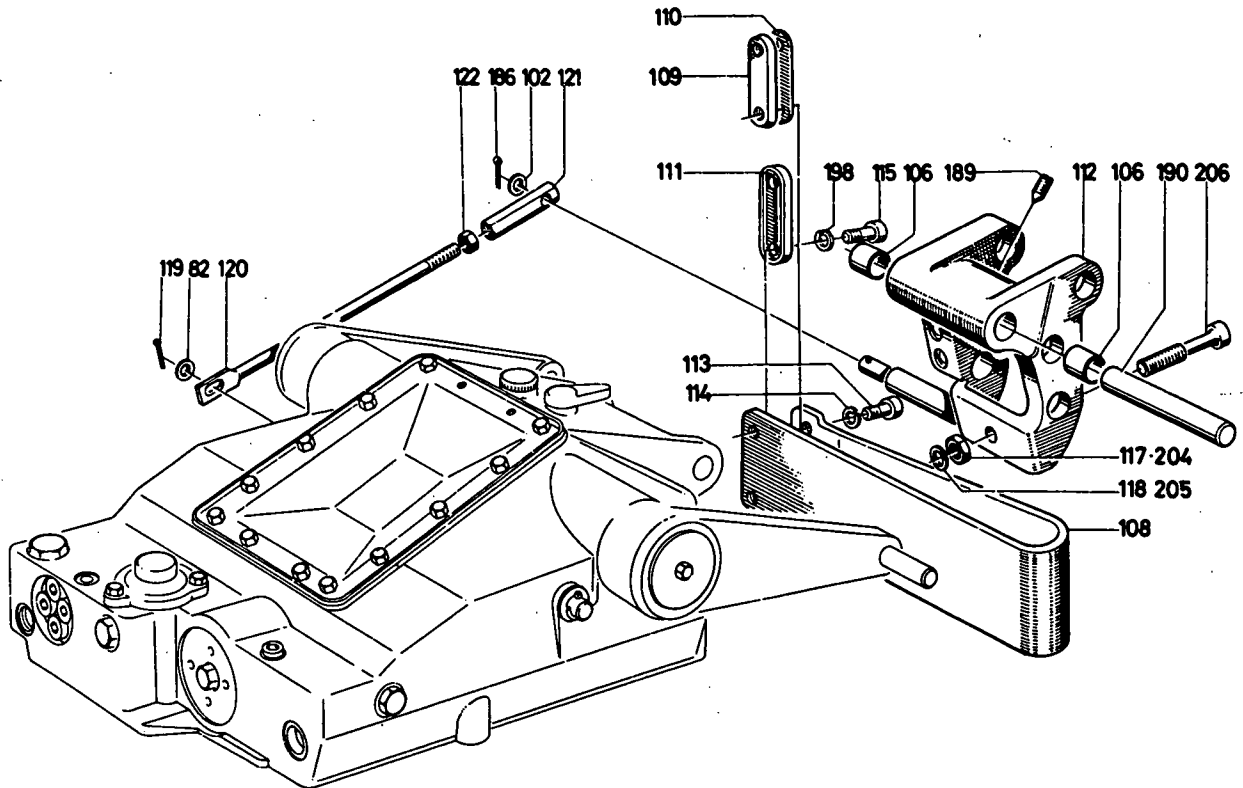

| Bild Nr. | Teil-Nr. | Stück-Zahl | Deutsch            | English           | Français           | Español            | 1952-08 502 0153<br>Nummer/Bemerkung              | ETK |
|----------|----------|------------|--------------------|-------------------|--------------------|--------------------|---|-----|
| 5        | 340 1267 | 1          | DICHTUNG           | GASKET            | GARNITURE/JOINT    | JUNTA              | 1952-08-43-06                                     |     |
| 6        | 340 1268 | 1          | DECKEL             | COVER             | COUVERCLE          | TAPA               | 1952-08-43-07                                     |     |
| 7        | 111 2277 | 10         | SECHSKANTSCHRAUBE  | HEX-BOLT          | VIS 6 PANS         | TORNILLO HEXAGONAL | M8x12 DIN 933-8-8-A4C                             |     |
| 8        | 116 7687 | 15         | SICHERUNGSSCHEIBE  | LOCKING WASHER    | RONDILLE SECURITE  | ARANDELA SEGURIDAD | 6M 2203   |     |
| 9        | 110 7548 | 16         | SCHLEIBE           | DISC/PANE/PLATE   | RONDILLE/DISQUE    | DISCO              | 6,4 DIN 933-ST-A4C                                |     |
| 13       | 230 6604 | 1          | ÖLMESSSTAB         | OIL DIPSTICK      | JAUGE D HUILE      | VARIL-NIVEL ACEITE |   |     |
| 14       | 238 0742 | 1          | DICHTRING          | WASHER            | BAGUE D ETANCHEITE | ANILLO DE JUNTA    | 1943-08-03-47                                     |     |
| 17       | 111 2624 | 4          | SECHSKANTMUTTER    | HEX-NUT           | ECROU 6 PANS       | TUERCA HEXAGONAL   | M 8 DIN 934-N 8 A4C                               |     |
| 19       | 110 8137 | 1          | SKT-ZAPPENSCHRAUBE | SPIGOT SCREW      | VIS 6 P A TETON    | TORN-HEX-C-ESPIGA  | M 8x20 DIN 561-5-8                                |     |
| 23       | 111 5440 | 1          | SPANNHUELSE        | DOWEL SLEEVE      | DOUILLE SERRAGE    | CASQUILLO FIADOR   | 5X32 DIN 1463                                     |     |
| 24       | 116 0037 | 2          | RUNDDICHTRING      | O-SEAL            | ANNEAU TORIQUE     | ANILLO JUNTA REDON | 16x2 H 2927-6I DEUTZ 9                            | 01  |
| 26       | 340 1320 | 1          | BUCHSE             | BUSH              | DOUILLE            | CASQUILLO          | 1952-08-55-24                                     |     |
| 27       | 230 6525 | 1          | BUCHSE             | BUSH              | DOUILLE            | CASQUILLO          |   |     |
| 28       | 116 0044 | 1          | RUNDDICHTRING      | O-SEAL            | ANNEAU TORIQUE     | ANILLO JUNTA REDON | 10x2 H 2927-6I DEUTZ 6                            | 01  |
| 34       | 112 3860 | 1          | SPANNHUELSE        | DOWEL SLEEVE      | DOUILLE SERRAGE    | CASQUILLO FIADOR   | 5X70 DIN 1463                                     |     |
| 35       | 112 4760 | 1          | VERSCHLUSSSCHRAUBE | SCREW PLUG        | BOUCHON FILETE     | TAPON ROSCADO      | M 26x1,5 DIN 908                                  |     |
| 36       | 111 8760 | 1          | DICHTRING          | WASHER            | BAGUE D ETANCHEITE | ANILLO DE JUNTA    | A 26x33 DIN 7603-CUXU                             |     |
| 37       | 340 0830 | 1          | SICHERHEITSENTIL   | SAFETY VALVE      | SOUPAPE SECURITE   | VALVULA SEGURIDAD  | 1943-08-26-10                                     |     |
| 38       | 111 8688 | 1          | DICHTRING          | WASHER            | BAGUE D ETANCHEITE | ANILLO DE JUNTA    | A 14x18 DIN 7603-CU                               |     |
| 39       | 111 0634 | 1          | ZYLINDERSCHRAUBE   | CHEESE-HEAD SCREW | VIS TETE CYLINDR.  | TORN-CBZA-CILIND.  | M 8x120 DIN 912-8-8                               |     |
| 40       | 340 1325 | 1          | DICHTRING          | WASHER            | BAGUE D ETANCHEITE | ANILLO DE JUNTA    | 1952-08-55-38                                     | 01  |
| 41       | 230 0706 | TN         | REGELSTEUERGERAET  | MAIN CONTROL UNIT | DISTRIBUTEUR PRINC | APTO-MANDO REGULAD | 8313-TEILENUMMERN-LISTENBLATT<br>1952-06 500 5132 |     |
| 42       | 331 5353 | 1          | DOPPELHOHLSCHRAUBE | BANJO BOLT        | VIS BANJO DOUBLE   | TORN-RACOR DOBLE   | 230 293 R   |     |
| 44       | 340 1327 | 1          | STELLSCHRAUBE      | SET SCREW         | VIS DE REGLAGE     | TORNILLO GRADUAC.  | 1952-08-55-43                                     |     |
| 45       | 111 8657 | 3          | DICHTRING          | WASHER            | BAGUE D ETANCHEITE | ANILLO DE JUNTA    | A 10 X 13,5 DIN 7603-CU                           |     |

| Bld Nr. | Teil-Nr. | Stück-Zahl | Deutsch            | English            | Français           | Español              | Numer/Bemerkung            | 01 |
|---------|----------|------------|--------------------|--------------------|--------------------|----------------------|----------------------------|----|
| 47      | 340 1242 | 1          | DRUCKFEDER         | COMPRESSION SPRING | RESSORT DE COMPR   | RESORTE PRESION      | 1952-08-11-46              |    |
| 48      | 230 1251 | 1          | VENTILSITZ         | VALVE SEAT         | SIEGE DE SOUPAPE   | ASIEN TO DE VALVULA  |                            |    |
| 49      | 340 1297 | 1          | HUELSE             | SLEEVE             | DOUILLE            | CASQUILLO            | 1952-08-41-56              |    |
| 50      | 233 5240 | 1          | STEUERLEITUNG      | CONTROL PIPE       | COND.-MUILE-PILOTE | TUBERIA DE MANDO     |                            |    |
| 51      | 116 6059 | 1          | RUNDDICHTRING      | O-SEAL             | ANNEAU TORIQUE     | ANILLO JUNTA REDON   | 40 X 3 H 721               | 01 |
| 53      | 111 5433 | 1          | SPANNHUELSE        | DOWEL SLEEVE       | DOUILLE SERRAGE    | CASQUILLO FIADOR     | 5X16 DIN 1481              |    |
| 54      | 116 0036 | 1          | RUNDDICHTRING      | O-SEAL             | ANNEAU TORIQUE     | ANILLO JUNTA REDON   | 10 X3 H 2927-61 DEUTZ 9    | 01 |
| 56      | 111 2305 | 2          | SECHSKANTSCHRAUBE  | HEX-BOLT           | VIS 6 PANS         | TORNILLO HEXAGONAL   | M8X150 DIN 933-M8-8-A4C    |    |
| 64      | 340 1328 | 9          | SICHERUNG          | FUSE/LOCK          | FUSIBLE/COUPE-CIRC | SEGURO/FUSIBLE       | 1952-08-55-66              |    |
| 65      | 340 1378 | 2          | ROLLE              | ROLLER             | ROULEAU/GALET      | RODILLO/POLEA        | 1952-08-78-03              |    |
| 66      | 111 0550 | 1          | ZYLINDERSCHRAUBE   | CHEESE-HEAD SCREW  | VIS TETE CYLINDR.  | TORN.-CBZA.-CILIND.  | M 8X 15DIN 912- 6-9        |    |
| 69      | 111 8713 | 2          | DICHTRING          | WASHER             | BAGUE D ETANCHEITE | ANILLO DE JUNTA      | A 18X22 DIN 7603-CUXU      |    |
| 70      | 111 8971 | 2          | VERSCHLUSSSCHRAUBE | SCREW PLUG         | BOUCHON FILETE     | TAPON ROSCADO        | M18X1,5 DIN 7604 VZKC      |    |
| 72      | 340 1400 | 1          | SEGMENT            | QUADRANT/SEGMENT   | SEGMENT/SECTEUR    | SEGMENTO             | 1952-08-95-62              |    |
| 73      | 340 1401 | 1          | LAGENMELDER        | POS N TRANSMITTER  | INDICATEUR POSIT.  | INDICADOR POSICION   | 1952-08-95-63              |    |
| 74      | 231 9764 | 1          | ROLLE              | ROLLER             | ROULEAU/GALET      | RODILLO/POLEA        | 1952-08-78-20              |    |
| 75      | 340 1402 | 2          | BOLZEN             | PIN/BOLT/STUD      | BOULON/AXE         | BULON                | 1952-08-95-64              |    |
| 78      | 340 1404 | 1          | ABSTANDBUCHSE      | SPACER BUSH        | DOUILLE ECARTEN    | CASQ.-DISTANCIARIO   | 1952-08-95-69              |    |
| 79      | 110 7557 | 1          | SCHEIBE            | DISC/PANE/PLATE    | RONDELLE/DISQUE    | DISCO                | 17 DIN 433                 |    |
| 80      | 340 1405 | 3          | SICHERUNG          | FUSE/LOCK          | FUSIBLE/COUPE-CIRC | SEGURO/FUSIBLE       | 1952-08-95-71              |    |
| 81      | 340 1406 | 1          | BOLZEN             | PIN/BOLT/STUD      | BOULON/AXE         | BULON                | 1952-08-95-72              |    |
| 82      | 110 7098 | 6          | SCHEIBE            | DISC/PANE/PLATE    | RONDELLE/DISQUE    | DISCO                | 8.4DIN 125                 |    |
| 83      | 340 1407 | 2          | LASCHE             | CONNECTING PLATE   | ECLISSE            | ECLISA               | 1952-08-95-73              |    |
| 84      | 340 1408 | 1          | LASTANZEIGEGERAET  | LOAD INDICATOR     | INDICATEUR CHARGE  | INDICADOR CARGA      | 1952-08-95-74              |    |
| 85      | 111 8323 | 1          | SCHEIBENFEDER      | WOODRUFF KEY       | CLAVETTE WOODRUFF  | CHAVETA MEDIA LUNA   | 3X5 DIN 6888               |    |
| 87      | 340 1390 | 1          | SCHWINGE           | SHACKLE            | BALANCIER          | BALANCIEN/PLUMA      | 1952-08-85-128             |    |
| 88      | 340 1391 | 1          | HEBEL              | LEVER/ARM          | LEVIER             | PALANCA              | 1952-08-85-129             |    |
| 89      | 340 1421 | 1          | STANGE             | ROD/BAR            | BARRE/TIGE/TRINGLE | BARRA/VARILLA        | 1952-08-113-10             |    |
| 92      | 340 1409 | 1          | SCHALTKULISSE      | SHIFT GATE         | COULISSE           | PLACA GUIA CAMBIO    | 1952-08-97-02              |    |
| 93      | 232 0492 | 1          | RING               | RING               | BAGUE/ANNEAU       | ANILLO               | 1952-08-114-10             |    |
| 94      | 340 1392 | 1          | PATRONE            | CARTRIDGE          | CARTOUCHE          | CARTUCHO             | 1952-08-85-136             |    |
| 95      | 110 8178 | 1          | SKT-ZAPFENSCHRAUBE | SPIGOT SCREW       | VIS 6 P A TETON    | TORN.-HEX.-C.-ESPIGA | M8 X35 DIN 561-5.8 CHRONAT |    |
| 97      | 230 6574 | 1          | WELLE              | SHAFT              | ARBRE              | EJE/ARBOL            |                            |    |
| 102     | 110 7105 | 1          | SCHEIBE            | DISC/PANE/PLATE    | RONDELLE/DISQUE    | DISCO                | A10.5 DIN 125-ST-A4C       |    |
| 106     | 231 2166 | 2          | BUCHSE             | BUSH               | DOUILLE            | CASQUILLO            |                            |    |
| 108     | 340 0133 | 1          | FEDER              | SPRING             | RESSORT            | RESORTE/BALLESTA     | 1925-08-11-72              |    |
| 109     | 340 0134 | 1          | LASCHE             | CONNECTING PLATE   | ECLISSE            | ECLISA               | 1925-08-11-73              |    |
| 110     | 340 0143 | 1          | BEILAGE            | SHIM               | CALE               | SUPLEMENTO           | 1925-08-11-114             |    |
| 111     | 340 0135 | 1          | LASCHE             | CONNECTING PLATE   | ECLISSE            | ECLISA               | 1925-08-11-74              |    |
| 112     | 233 1345 | 1          | GEBERSCHWINGE      | ROCKER             | CHAPE OSCILLANTE   | BALANCIEN TRANSMIS.  | 1952-08-82-110             |    |
| 113     | 111 0782 | 2          | ZYLINDERSCHRAUBE   | CHEESE-HEAD SCREW  | VIS TETE CYLINDR.  | TORN.-CBZA.-CILIND.  | M12X 70DIN 912-10-9        |    |
| 114     | 111 9615 | 2          | FEDERRING          | SPRING LOCKWASHER  | RONDELLE GROMER    | ARANDELA ELASTICA    | 12DIN 7980 VZKC            |    |
| 115     | 111 0764 | 2          | ZYLINDERSCHRAUBE   | CHEESE-HEAD SCREW  | VIS TETE CYLINDR.  | TORN.-CBZA.-CILIND.  | M12X40 DIN 912-10-9-A4C    |    |
| 117     | 111 2858 | 1          | SECHSKANTMUTTER    | HEX-NUT            | ECROU 6 PANS       | TUERCA HEXAGONAL     | M12 DIN 934 M8 A4C         |    |
| 118     | 340 0162 | 1          | SCHEIBE            | DISC/PANE/PLATE    | RONDELLE/DISQUE    | DISCO                | 1925-08-17-10              |    |
| 119     | 110 6407 | 1          | SPLINT             | SPLIT PIN          | GOUPILLE FENDUE    | PASADOR ALETAS       | 2X15 DIN 96 VZKC           |    |
| 120     | 232 6790 | 1          | VERSTELLSTANGE     | ADJUSTING ROD      | TRINGLE DE REGLAGE | BARRA GRADUAC.       |                            |    |
| 121     | 340 1303 | 1          | EINSTELLMUTTER     | ADJUSTING NUT      | ECROU DE REGLAGE   | TUERCA GRADUAC.      | 1952-08-41-102             |    |
| 122     | 111 2852 | 1          | SECHSKANTMUTTER    | HEX-NUT            | ECROU 6 PANS       | TUERCA HEXAGONAL     | M10 X1 DIN 934-M 8 A4C     |    |
| 126     | 347 1298 | 1          | STOPFEN            | PLUG               | BOUCHON            | TAPON                | 1952-08-95-38              |    |
| 127     | 116 1641 | 1          | RUNDDICHTRING      | O-SEAL             | ANNEAU TORIQUE     | ANILLO JUNTA REDON   | 64X3 H 2927-61 DEUTZ 6     | 01 |
| 128     | 347 1299 | 1          | MUTRING            | V-SEAL             | BAGUE RAINUREE     | ANILLO RANURADO      | 1952-08-95-43              | 01 |

| Blz Nr. | Teil-Nr. | Stück-Zahl | Deutsch            | English            | Français           | Español            | 1952-08 502 0133<br>Nummer/Bemerkung              |
|---------|----------|------------|--------------------|--------------------|--------------------|--------------------|---|
| 129     | 347 4299 | 1          | KOLBEN             | PISTON/PLUNGER     | PISTON             | EMBOLO/PISTON      | 1952-08-95-44                                     |
| 130     | 347 1301 | 1          | PLEUEL             | CONNECTING ROD     | BIELLE             | BIELA              | 1952-08-95-45                                     |
| 132     | 347 5234 | 2          | HEBEARM            | LIFT ARM           | BRAS DE LEVAGE     | BRAZO ELEVAC.      | 1952-08-103-10                                    |
| 133     | 347 1304 | 1          | RING               | RING               | BAGUE/ANNEAU       | ANILLO             | 1952-08-95-78                                     |
| 134     | 231 2185 | 1          | DICHRING           | WASHER             | BAGUE D ETANCHEITE | ANILLO DE JUNTA    |   |
| 137     | 231 2186 | 1          | DICHRING           | WASHER             | BAGUE D ETANCHEITE | ANILLO DE JUNTA    |   |
| 138     | 347 1307 | 1          | RING               | RING               | BAGUE/ANNEAU       | ANILLO             | 1952-08-95-84                                     |
| 140     | 340 1326 | 1          | KIPPHEBEL          | ROCKER ARM         | CULBUTEUR          | BALANCIN           | 1952-08-55-42                                     |
| 141     | 231 4739 | 1          | WELLE              | SHAFT              | ARBRE              | EJE/ARBOL          | 1952-08-101-10                                    |
| 167     | 230 6602 | 1          | ABSTANDBUCHSE      | SPACER BUSH        | DOUILLE ECARTEN    | CASQ. DISTANCIARIO |   |
| 177     | 230 1250 | 1          | VENTIL             | VALVE              | SOUPAPE/ROBINET    | VALVULA            |   |
| 179     | 231 2039 | 1          | HEBEL              | LEVER/ARM          | LEVIER             | PALANCA            |   |
| 185     | 111 5479 | 1          | SPANNHUELSE        | DOWEL SLEEVE       | DOUILLE SERRAGE    | CASQUILLO FIADOR   | 8X55 DIN 1481                                     |
| 186     | 110 6435 | 1          | SPLINT             | SPLIT PIN          | GOUPILLE FENDUE    | PASADOR ALETAS     | 3 X 25DIN 94 VZKC                                 |
| 187     | 231 4780 | 1          | GEWINDESTIFT       | GRUB SCREW         | GOUPILLE FILETEE   | PERNO ROSCADO      |   |
| 190     | 110 2335 | 1          | BOLZEN             | PIN/BOLT/STUD      | BOULON/AXE         | BULON              | 25111X135 DIN 1433-MST50-2K                       |
| 191     | 347 1292 | 1          | ROLLE              | ROLLER             | ROULEAU/GALET      | RODILLO/POLEA      | 1952-08-78-05                                     |
| 193     | 231 4874 | 1          | STANGE             | ROD/BAR            | BARRE/TIGE/TRINGLE | BARRA/VARILLA      |   |
| 194     | 231 4872 | 1          | ZUGSTANGE          | PULLROD            | TIRANT             | BARRA TRACCION     |   |
| 198     | 110 7237 | 2          | FEDERRING          | SPRING LOCKWASHER  | RONDELLE GROMER    | ARANDELA ELASTICA  | 812 DIN 127 VZKC                                  |
| 199     | 111 3389 | 4          | STIFTSCHRAUBE      | STUD               | GOUJON             | ESPARRAGO          | M 8X25 DIN 939-6-8-A4C                            |
| 204     | 111 3152 | 1          | SECHSKANTMUTTER    | HEX-NUT            | ECROU 6 PANS       | TUERCA HEXAGONAL   | M12 DIN 936-M55 VZKC                              |
| 205     | 110 7110 | 1          | SCHEIBE            | DISC/PANE/PLATE    | RONDELLE/DISQUE    | DISCO              | A 13 DIN 125-ST-A4C                               |
| 206     | 233 1564 | 1          | STELLSCHRAUBE      | SET SCREW          | VIS DE REGLAGE     | TORNILLO GRADUAC.  |   |
| 210     | 233 1617 | 1          | GRIFF              | HANDLE             | POIGNEE/MANETTE    | PUNO/ASA           |   |
| 224     | 116 7311 | 4          | VERSCHLUSSSTOPFEN  | NIPPLE             | BOUCHON            | TAPON OBTURADOR    | A 9 H 2873  |
| 235     | 347 1291 | F 1        | ROLLE              | ROLLER             | ROULEAU/GALET      | RODILLO/POLEA      | 1952-08-78-04                                     |
| 241     | 237 5478 | 1          | ÖLLEITUNG          | OIL LINE           | CONDUITE D HUILE   | TUBERIA ACEITE     |   |
| 242     | 237 7480 | 3          | STIFTSCHRAUBE      | STUD               | GOUJON             | ESPARRAGO          |   |
| 243     | 110 7279 | 3          | FEDERSCHEIBE       | SPRING WASHER      | RONDELLE ELASTIQUE | ARANDELA ELASTICA  | 8 6 DIN 137-A4C                                   |
| 244     | 111 2813 | 3          | SECHSKANTMUTTER    | HEX-NUT            | ECROU 6 PANS       | TUERCA HEXAGONAL   | M 6 DIN 934-M 8 A4C                               |
| 247     | 237 4684 | 1          | WELLE              | SHAFT              | ARBRE              | EJE/ARBOL          |   |
| 250     | 112 6162 | 2          | SECHSKANTSCHRAUBE  | HEX-BOLT           | VIS 6 PANS         | TORNILLO HEXAGONAL | M 8X25 DIN 933 M8-8                               |
| 252     | 110 7955 | 3          | SCHLITZMUTTER      | SLOTTED NUT        | ECROU FENDU        | TUERCA RANURADA    | M 6 DIN 546-6                                     |
| 256     | 238 2491 | 1          | KRAFTHEBERGEMAEUSE | LIFT HOUSING       | CORPS VERIN HYDRAU | BLOQUE ELEV-HIDR.  |   |
| 263     | 238 4654 | 2          | SCHEIBE            | DISC/PANE/PLATE    | RONDELLE/DISQUE    | DISCO              |   |
| 266     | 237 4661 | TN         | REGELSTEUERGERAET  | MAIN CONTROL UNIT  | DISTRIBUTEUR PRINC | APTO-MANDO REGULAD | 8313-TEILENUMMERN-LISTENBLATT<br>1952-08 502 0133 |
| 270     | 110 7969 | 1          | GEWINDESTIFT       | GRUB SCREW         | GOUPILLE FILETEE   | PERNO ROSCADO      | M6X6 DIN 551-5-8                                  |
| 271     | 340 1282 | 1          | DRUCKFEDER         | COMPRESSION SPRING | RESSORT DE COMPR   | RESORTE PRESION    | 1952-08-11-46                                     |
| 272     | 230 1251 | 1          | VENTILSITZ         | VALVE SEAT         | SIEGE DE SOUPAPE   | ASIENTO DE VALVULA |   |
| 273     | 230 1250 | 1          | VENTIL             | VALVE              | SOUPAPE/ROBINET    | VALVULA            |   |
| 274     | 237 7200 | 1          | RIEGEL             | LATCH/CATCH        | VERROU             | CERROJO            |   |
| 280     | 237 9114 | 1          | FILTERDECKEL       | COVER              | COUVERCLE DE FILTR | TAPA FILTRO        |   |
| 281     | 237 5476 | 2          | DICHTUNG           | GASKET             | GARNITURE/JOINT    | JUNTA              |   |
| 282     | 237 1583 | 1          | PATRONE            | CARTRIDGE          | CARTOUCHE          | CARTUCHO           |   |
| 283     | 237 5479 | 1          | VENTIL             | VALVE              | SOUPAPE/ROBINET    | VALVULA            |   |
| 284     | 237 1122 | 1          | ABSTANDRING        | SPACER RING        | BAGUE ECARTEMENT   | ARO DISTANCIARIO   |   |
| 285     | 238 0014 | SZ         | FILTERPATRONE      | CARTRIDGE          | CARTOUCHE FILTRANT | CARTUCHO FILTRO    |   |
| 286     | 233 1959 | 1          | BOLZEN             | PIN/BOLT/STUD      | BOULON/AXE         | BULON              |   |
| 290     | 340 1321 | 1          | STIFT              | PIN                | CHEVILLE/GOUPILLE  | PERNO/PASADOR      | 1952-08-55-29                                     |
| 291     | 116 5842 | 1          | KERNLOCHVERSCHLUSS | CORE HOLE PLUG     | BOUCHON TROU DESS  | CIERRE MACHO       | 8 60 H 711  |

| Bd<br>Nr. | Teil-Nr. | Stück-<br>Zahl | 1952-08 502        |                |                    |                    | Nummer/Bemerkung |
|-----------|----------|----------------|--------------------|----------------|--------------------|--------------------|------------------|
|           |          |                | Deutsch            | English        | Français           | Español            |                  |
| 292       | 347 1305 | 1              | LAGERBUCHSE        | BEARING BUSH   | BAGUE DE PALIER    | CASQU-COJINETE     | 1952-08-95-81    |
| 293       | 230 6597 | 1              | ENTLUEFTUNGSROHR   | BREATHER PIPE  | TUBE DE DESAERAGE  | TUBO PRG-AIRE      |                  |
| 294       | 116 5827 | 2              | KERNLOCHVERSCHLUSS | CORE HOLE PLUG | BOUCHON TROU DESS  | CIERRE MACHO       | 818 H 711        |
| 295       | 232 0098 | 1              | SAUGFILTER         | INTAKE FILTER  | FILTRE ASPIRAT     | FILTRO ASPIRACION  |                  |
| 296       | 347 1306 | 1              | LAGERBUCHSE        | BEARING BUSH   | BAGUE DE PALIER    | CASQU-COJINETE     | 1952-08-95-82    |
| 297       | 238 2233 | 1              | KRAFTHEBERGEGAEUSE | LIFT HOUSING   | CORPS VERIN HYDRAU | BLOQUE ELEV-HIDR.  |                  |
| 300       | 230 6581 | 1              | ENTLUEFTUNGSROHR   | BREATHER PIPE  | TUBE DE DESAERAGE  | TUBO PRG-AIRE      |                  |
| 301       | 340 0021 | 1              | SCHNUEFFELVENTIL   | SNIFTING VALVE | RENIFLARD          | VALVULA RONCADORA  | 1925-01-02-05    |
| 302       | 110 6398 | 1              | SPLINT             | SPLIT PIN      | GOUPILLE FENDUE    | PASADOR ALETAS     | 1,5X 30DIN 94    |
| 306       | 232 0095 | 1              | SIEBEINSATZ        | STRAINER       | ELEMENT TAMISANT   | ELEMENTO TANIZ     |                  |
| 307       | 232 0096 | 1              | FEDERRUEGEL        | SPRING CLAMP   | ETRIER DE RESSORT  | ESTRIBO RESORTE    |                  |
| 308       | 233 1567 | 1              | RUNDDICHTRING      | O-SEAL         | ANNEAU TORIQUE     | ANILLO JUNTA PEDON |                  |

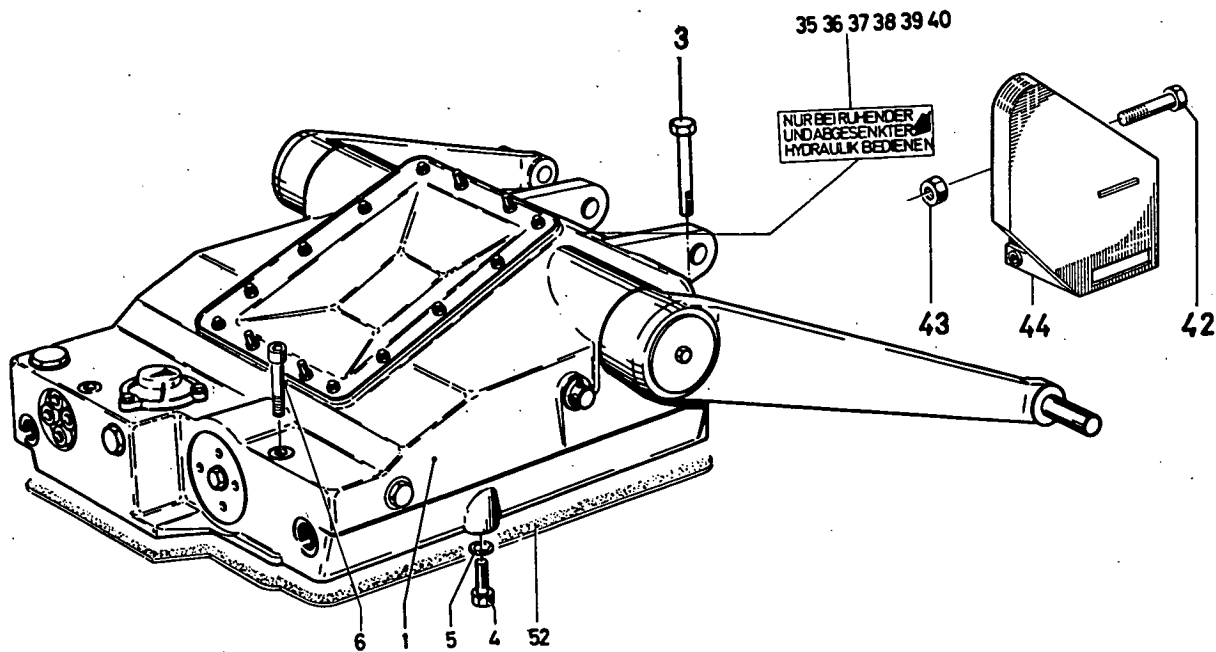

1952-08 500 5121

| Bld. Nr. | Teil-Nr. | Stück-Zahl | Deutsch           | English           | Français          | Español            | Nummer / Bemerkung   | ETK |
|----------|----------|------------|-------------------|-------------------|-------------------|--------------------|--|-----|
| 1        | 230 3557 | 1          | KRAFTHEBER        | HYDRAULIC LIFT    | VERIN HYDRAULIQUE | ELEVADOR HIDRAUL.  | 8313-TEILENUMMERN-LISTENBLATT<br>1952-08 500 6240                        |     |
| 3        | 111 1780 | 2          | SECHSKANTSCHRAUBE | HEX-BOLT          | VIS 6 PANS        | TORNILLO HEXAGONAL | M14X 110 DIN 933-M 8-8 A4C   |     |
| 4        | 111 2429 | 2          | SECHSKANTSCHRAUBE | HEX-BOLT          | VIS 6 PANS        | TORNILLO HEXAGONAL | M10X 30 DIN 933- 8-8-A4C   |     |
| 5        | 116 9694 | 2          | SICHERUNGSSCHEIBE | LOCKING WASHER    | RONDELLE SECURITE | ARANDELA SEGURIDAD | 10 H 2203  |     |
| 6        | 112 4782 | 2          | ZYLINDERSCHRAUBE  | CHEESE-HEAD SCREW | VIS TETE CYLINDR. | TORN-CBZA-CILIND.  | M14X 130DIN 912-10-9 PHOSPH  |     |
| 35       | 121 0622 | 1P         | BEDIENUNGSSCHILD  | INSTRUCTION PLATE | PLAQUE INSTRUCTNS | ROTULO SERVICIO    | 4 308 A 634<br>8313-TEILENUMMERN-LISTENBLATT<br>1001-71 502 0151 POS.21  |     |
| 36       | 121 0643 | 1P         | BEDIENUNGSSCHILD  | INSTRUCTION PLATE | PLAQUE INSTRUCTNS | ROTULO SERVICIO    | 4 308 F 634<br>8313-TEILENUMMERN-LISTENBLATT<br>1001-71 502 0151 POS.954 |     |
| 37       | 121 0644 | 1P         | BEDIENUNGSSCHILD  | INSTRUCTION PLATE | PLAQUE INSTRUCTNS | ROTULO SERVICIO    | 4 308 C 634<br>8313-TEILENUMMERN-LISTENBLATT<br>1001-71 502 0151 POS.951 |     |
| 38       | 121 0645 | 1P         | BEDIENUNGSSCHILD  | INSTRUCTION PLATE | PLAQUE INSTRUCTNS | ROTULO SERVICIO    | 4 308 J 634<br>8313-TEILENUMMERN-LISTENBLATT<br>1001-71 502 0151 POS.953 |     |
| 39       | 121 0646 | 1P         | BEDIENUNGSSCHILD  | INSTRUCTION PLATE | PLAQUE INSTRUCTNS | ROTULO SERVICIO    | 4 308 D 634<br>8313-TEILENUMMERN-LISTENBLATT<br>1001-71 502 0151 POS.952 |     |
| 40       | 121 0647 | 1P         | BEDIENUNGSSCHILD  | INSTRUCTION PLATE | PLAQUE INSTRUCTNS | ROTULO SERVICIO    | 4 308 B 634<br>8313-TEILENUMMERN-LISTENBLATT<br>1001-71 502 0151 POS.950 |     |
| 42       | 111 0543 | 2          | ZYLINDERSCHRAUBE  | CHEESE-HEAD SCREW | VIS TETE CYLINDR. | TORN-CBZA-CILIND.  | M 6X 70DIN 912- 6-9 VZKC   |     |
| 43       | 111 4357 | 2          | SECHSKANTMUTTER   | HEX.NUT           | ECROU 6 PANS      | TUERCA HEXAGON.    | M 6 DIN 985- 8 VZKC  |     |
| 44       | 232 3719 | 1          | ABWEISER          | DEFLECTOR         | DEFLECTEUR        | DEFLECTOR          |  |     |
| 52       | 233 8834 | 1          | DICHTUNG          | GASKET            | GARNITURE/JOINT   | JUNTA              |  |     |

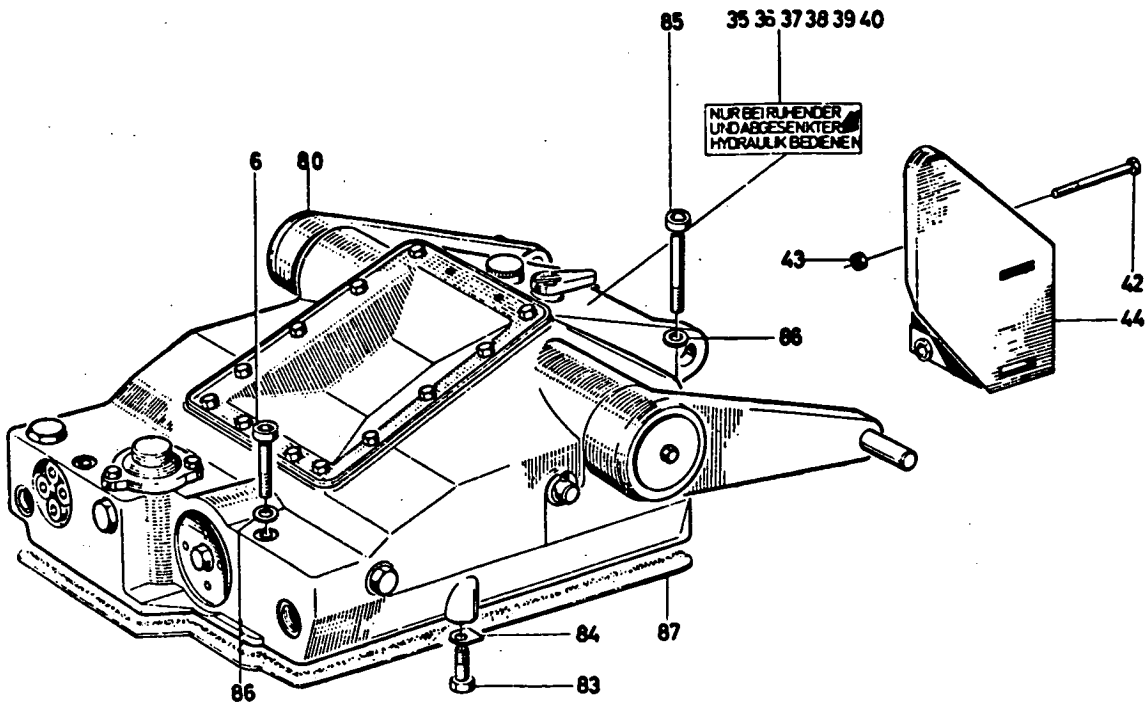

1952-08 502 0152

| Bad Nr. | Teile-Nr. | Stück-Zahl | Deutsch            | English           | Français          | Español            | Numer/Bemerkung  | BTM |
|---------|-----------|------------|--------------------|-------------------|-------------------|--------------------|--|-----|
| 6       | 112 4782  | 2          | ZYLINDERSCHRAUUE   | CHEESE-HEAD SCREW | VIS TETE CYLINDR. | TORN-GB2A-CILIND.  | M14X 130DIN 912-10-9 PHOSPH  |     |
| 35      | 121 0622  | IP         | BEDIENUNGSSCHILD   | INSTRUCTION PLATE | PLAQUE INSTRUCTNS | ROTULO SERVICIO    | 4 308 A 634<br>8313-TEILENUMMERN-LISTEN BLATT<br>1001-71 502 0151 POS.21 |     |
| 36      | 121 0643  | IP         | BEDIENUNGSSCHILD   | INSTRUCTION PLATE | PLAQUE INSTRUCTNS | ROTULO SERVICIO    | 4 308 F 634<br>8313-TEILENUMMERN-LISTENBLATT<br>1001-71 502 0151 POS.954 |     |
| 37      | 121 0644  | IP         | BEDIENUNGSSCHILD   | INSTRUCTION PLATE | PLAQUE INSTRUCTNS | ROTULO SERVICIO    | 4 308 C 634<br>8313-TEILENUMMERN-LISTENBLATT<br>1001-71 502 0151 POS.951 |     |
| 38      | 121 0645  | IP         | BEDIENUNGSSCHILD   | INSTRUCTION PLATE | PLAQUE INSTRUCTNS | ROTULO SERVICIO    | 4 308 J 634<br>8313-TEILENUMMERN-LISTENBLATT<br>1001-71 502 0151 POS.953 |     |
| 39      | 121 0646  | IP         | BEDIENUNGSSCHILD   | INSTRUCTION PLATE | PLAQUE INSTRUCTNS | ROTULO SERVICIO    | 4 308 D 634<br>8313-TEILENUMMERN-LISTENBLATT<br>1001-71 502 0151 POS.952 |     |
| 40      | 121 0647  | IP         | BEDIENUNGSSCHILD   | INSTRUCTION PLATE | PLAQUE INSTRUCTNS | ROTULO SERVICIO    | 4 308 B 634<br>8313-TEILENUMMERN-LISTENBLATT<br>1001-71 502 0151 POS.950 |     |
| 42      | 111 0543  | 2          | ZYLINDERSCHRAUUE   | CHEESE-HEAD SCREW | VIS TETE CYLINDR. | TORN-GB2A-CILIND.  | M6X70 DIN 912-6-9 ANC  |     |
| 43      | 111 4357  | 2          | SECHSKANTMUTTER    | HEX-NUT           | ECROU 6 PANS      | TUERCA HEXAGONAL   | M 6 DIN 934- 8 VZKC  |     |
| 44      | 232 3719  | 1          | ABWEISER           | DEFLECTOR         | DEFLECTEUR        | DEFLECTOR          |  |     |
| 80      | 238 2473  | 1          | KRAFTHEBER         | HYDRAULIC LIFT    | VERIN HYDRAULIQUE | ELEVADOR HIDRAUL-  |  |     |
| 83      | 116 2827  | 2          | SICHERUNGSSCHRAUBE | LOCKING SCREW     | VIS D ARRET       | TORNILLO AFIANZAD. | AM 12X40 M 200-13C   |     |
| 84      | 238 0547  | 2          | SCHIEBE            | DISC/PANE/PLATE   | RONDELLE/DISQUE   | DISCO              |  |     |
| 85      | 113 6346  | 2          | ZYLINDERSCHRAUUE   | CHEESE-HEAD SCREW | VIS TETE CYLINDR. | TORN-GB2A-CILIND.  | M 14X135 DIN 912-10-9 ANC  |     |
| 86      | 116 9672  | 4          | SCHIEBE            | DISC/PANE/PLATE   | RONDELLE/DISQUE   | DISCO              | 14-5X28X 6H 995-86   |     |
| 87      | 238 4619  | 1          | DICHTUNG           | GASKET            | GARNITURE/JOINT   | JUNTA              |  |     |



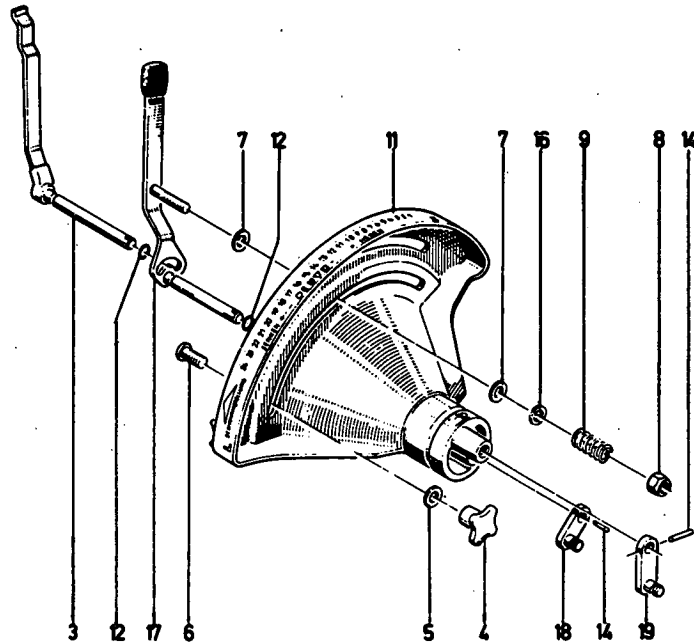

1952-08 500 6175

| Bild-Nr | Teile-Nr. | Stück-Zahl | Deutsch         | English            | Français         | Español            | Nummer/Bemerkung    | ETK |
|---------|-----------|------------|-----------------|--------------------|------------------|--------------------|---------------------|-----|
| 3       | 340 1412  | 1          | HEBEL           | LEVER/ARM          | LEVIÉR           | PALANCA            | 1952-08-107-10      |     |
| 4       | 111 7557  | 1          | KREUZGRIFF      | STAR KNOB          | CROISILLON       | PUNO CRUCETA       | D40DIN 6335-66      |     |
| 5       | 110 7101  | 1          | SCHLEIBE        | DISC/PANE/PLATE    | RONDELLE/DISQUE  | DISCO              | A 6.4DIN 125-ST-A4C |     |
| 6       | 340 1281  | 1          | SCHRAUBE        | SCREW/BOLT         | VIS/BOULON       | TORNILLO           | 1952-08-02-09       |     |
| 7       | 340 1367  | 2          | BREMSSCHEIBE    | BRAKE DISC         | DISQUE DE FREIN  | DISCO FRENO        | 1952-08-70-06       |     |
| 8       | 111 4356  | 1          | SECHSKANTMUTTER | HEX-NUT            | ECROU 6 PANS     | TUERCA HEXAGONAL   | M 6 DIN 985- 8      |     |
| 9       | 340 1368  | 1          | DRUCKFEDER      | COMPRESSION SPRING | RESSORT DE COMPR | RESORTE PRESION    | 1952-08-70-08       | 01  |
| 11      | 340 1411  | 1          | SEGMENT         | QUADRANT/SEGMENT   | SEGMENT/SECTEUR  | SEGMENTO           | 1952-08-106-11      |     |
| 12      | 340 1398  | 2          | RUNDGUMMIRING   | O-SEAL             | ANNEAU TORIQUE   | ANILLO GOMA REDOND |                     | 01  |
| 14      | 111 5407  | 2          | SPANNHUELSE     | DOWEL SLEEVE       | DOUILLE SERRAGE  | CASQUILLO FIADOR   | 3 X 16 DIN 1481     |     |
| 16      | 110 7095  | 1          | SCHLEIBE        | DISC/PANE/PLATE    | RONDELLE/DISQUE  | DISCO              | A 6.4DIN 125-ST-A4C |     |
| 17      | 231 7206  | 1          | HEBEL           | LEVER/ARM          | LEVIÉR           | PALANCA            |                     |     |
| 18      | 231 4868  | 1          | KURBELSCHEIBE   | CRANK DISC         | DISQUE MANIVELLE | DISCO MANIVELA     |                     |     |
| 19      | 231 4870  | 1          | KURBELSCHEIBE   | CRANK DISC         | DISQUE MANIVELLE | DISCO MANIVELA     |                     |     |

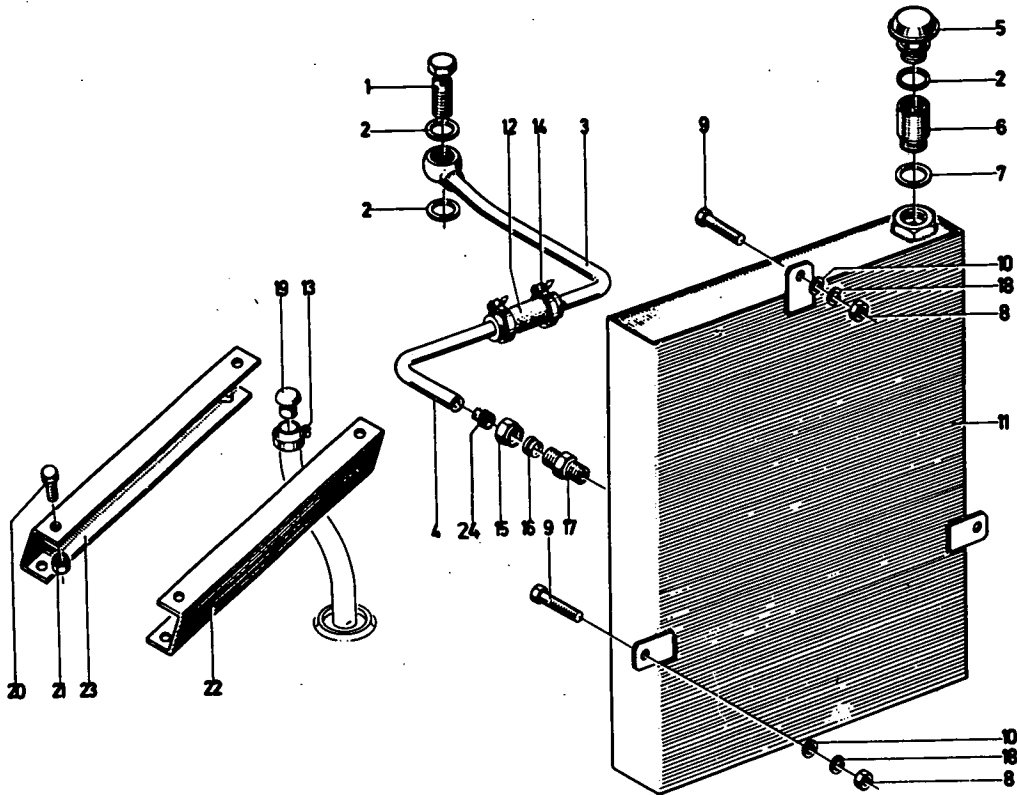

1952-08 500 5137

| Bild Nr. | Teil-Nr. | Stück-Zahl | Deutsch            | English           | Français           | Español            | Nummer/Bemerkung         | ETK |
|----------|----------|------------|--------------------|-------------------|--------------------|--------------------|--------------------------|-----|
| 1        | 116 7917 | 1          | HOHLSCHRAUBE       | BANJO BOLT        | VIS BANJO          | TORNILLO RACOR     | A25H 3102                |     |
| 2        | 111 8784 | 3          | DICHRING           | WASHER            | BAGUE D ETANCHEITE | ANILLO DE JUNTA    | A 30 X 36 DIN 7603-CU    |     |
| 3        | 233 2036 | 1          | ROHRLEITUNG        | PIPE/LINE         | TUYAUSERIE         | TUBERIA            |                          |     |
| 4        | 233 2063 | 1          | ROHR               | PIPE/TUBE         | TUBE/TUYAU         | TUBO               |                          |     |
| 5        | 126 6675 | 1          | ENTLUEFTUNGSEILTER | BREATHER FILTER   | FILTRE D AIR VENT  | FILTRO VENTILAC.   |                          |     |
| 6        | 233 2820 | 1          | HUELSE             | SLEEVE            | DOUILLE            | CASQUILLO          |                          |     |
| 7        | 238 0742 | 1          | DICHRING           | WASHER            | BAGUE D ETANCHEITE | ANILLO DE JUNTA    | 1941-08-01-49            |     |
| 8        | 110 2659 | 3          | SECHSKANTMUTTER    | HEX-NUT           | ECROU 6 PANS       | TUERCA HEXAGONAL   | M10 DIN 934-M 8 A4C      |     |
| 9        | 111 2439 | 3          | SECHSKANTSCHRAUBE  | HEX-BOLT          | VIS 6 PANS         | TORNILLO HEXAGONAL | M10X 35 DIN 933- 8-8-A4C |     |
| 10       | 338 7988 | 3          | RING               | RING              | BAGUE/ANNEAU       | ANILLO             | 1125-49-11-21            |     |
| 11       | 233 2038 | 1          | OELBEHAELTER       | OIL RESERVOIR     | RESERVOIR D HUILE  | TANQUE ACEITE      |                          |     |
| 12       | 116 4153 | 1          | SCHLAUCH           | HOSE              | FLEXIBLE           | MANGUERA           | A25 X34 X 100H 7760      | 01  |
| 13       | 112 8266 | 1          | SCHLAUCHSCHELLE    | HOSE CLIP         | COLLIER SERRAGE    | ABRAZADENA MANGUER | LA 12- 20DIN 3017-W1     |     |
| 14       | 116 6376 | 2          | SCHLAUCHSCHELLE    | HOSE CLIP         | COLLIER SERRAGE    | ABRAZADERA MANGUER | S 36X12 H 735            |     |
| 15       | 110 2372 | 2          | UEBERWURFMUTTER    | UNION NUT         | ECROU-RACCORD      | TUERCA EMPALME     | AL 28DIN 3870 VZKC       |     |
| 16       | 111 6632 | 2          | SCHNEIDRING        | CUTTING RING      | BAGUE TRANCHANTE   | ANILLO CORTANTE    | L 28DIN 3861-ST          |     |
| 17       | 111 6695 | 1          | VERBINDUNGSSTUTZEN | UNION             | RACCORD            | TUBILADURA UNION   | L 28M DIN 3901           |     |
| 18       | 110 2800 | 3          | FEDERRING          | SPRING LOCKWASHER | RONDELLE GROUPE    | ARANDELA ELASTICA  | A 10 DIN 128 A4C         |     |
| 19       | 116 7320 | 1          | VERSCHLUSSSTOPFEN  | NIPPLE            | BOUCHON            | TAPON OBTURADOR    | A17 H 2873               |     |
| 20       | 111 2311 | 4          | SECHSKANTSCHRAUBE  | HEX-BOLT          | VIS 6 PANS         | TORNILLO HEXAGONAL | M 8X 18 DIN 933- 8-8-A4C |     |
| 21       | 111 2824 | 4          | SECHSKANTMUTTER    | HEX-NUT           | ECROU 6 PANS       | TUERCA HEXAGONAL   | M 8 DIN 934-M 8 A4C      |     |
| 22       | 232 1074 | 1          | STUETZE            | SUPPORT           | SUPPORT/APPUI      | APOYO              | 8195-LINKS               |     |
| 23       | 232 1075 | 1          | STUETZE            | SUPPORT           | SUPPORT/APPUI      | APOYO              | 8267-RECHTS              |     |
| 24       | 117 1244 | 1          | VERSTAERKGS-HUELSE | STIFFENING SLEEVE | DOUILLE RENFORT    | CASQUILLO REFUERZO | 28X1,5H 3111             |     |

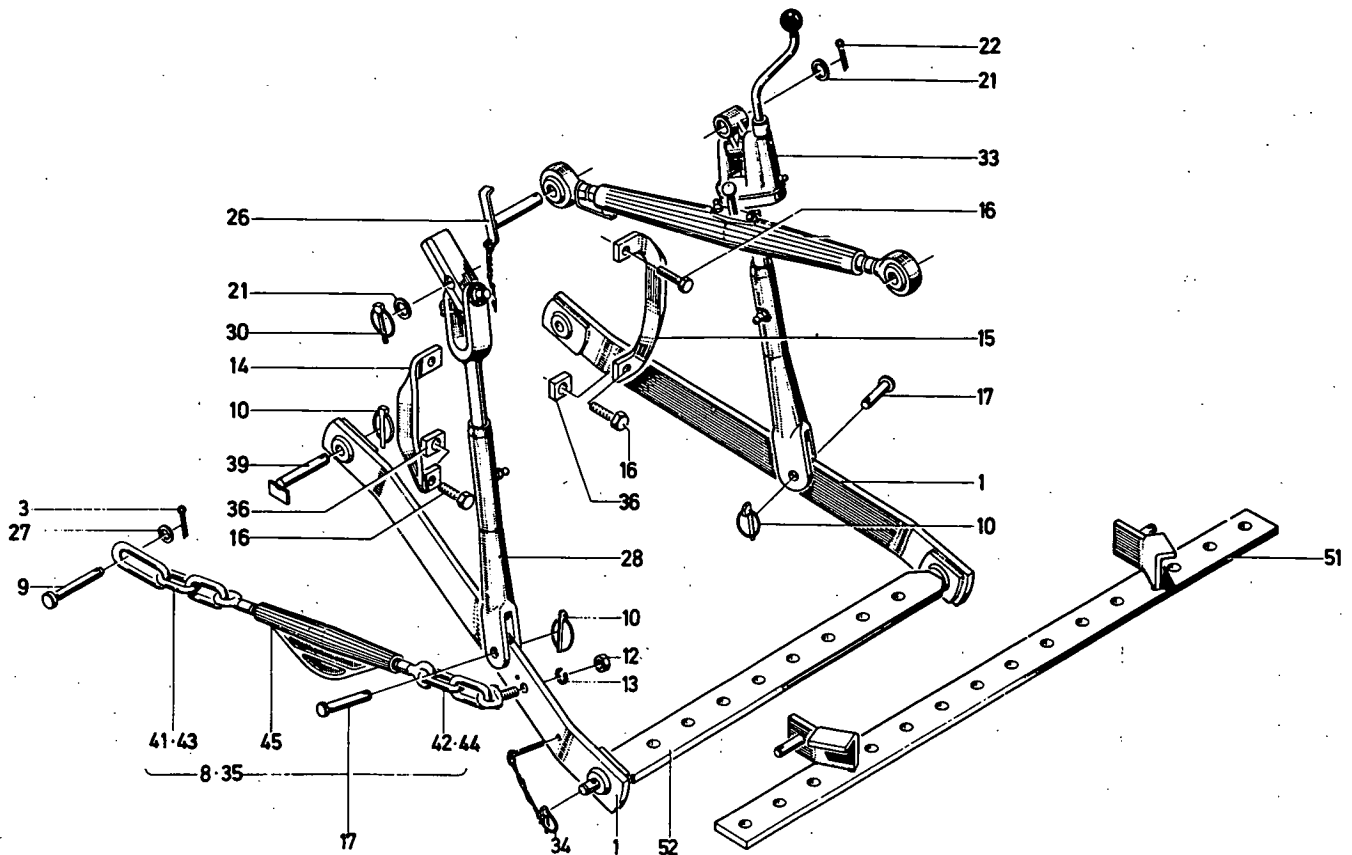

1926-11 500 5126

| Bild Nr. | Teile-Nr. | Stück-Zahl | Deutsch           | English           | Français           | Español            | Nummer/Bemerkung  | ETK |
|----------|-----------|------------|-------------------|-------------------|--------------------|--------------------|---|-----|
| 1        | 230 1355  | 2          | UNTERER-LENKER    | BOTTOM LINK       | BRAS INFÉRIEUR     | GUIA INFERIOR      |   |     |
| 3        | 110 6468  | 2          | SPLINT            | SPLIT PIN         | GOUPILLE FENDUE    | PASADOR ALETAS     | 5 X 30 DIN 94-A4C   |     |
| 8        | 347 1268  | 1          | SPANNKETTE        | TENSIONING CHAIN  | CHAÎNE DE TENSION  | CADENA TENSORA     | 1941-11-31.10<br>B197, LINKS-VOLLSTAENDIG<br>B050, BESTEM. AUS POS. 42, 43+45 |     |
| 9        | 340 0835  | 2          | BOLZEN            | PIN/BOLT/STUD     | BOULON/AXE         | BULON              | 1941-11-30.15   |     |
| 10       | 340 0205  | 4          | KLAPPSTECKER      | FOLDING PLUG      | FICHE PLIANTE      | CLAVIJA ARTICULADA | 1925-11-29.33   |     |
| 12       | 111 2886  | 2          | SECHSKANTMUTTER   | HEX-NUT           | ECROU 6 PANS       | TUERCA HEXAGONAL   | M16 DIN 934-M 8 A4C   |     |
| 13       | 110 2803  | 2          | FEDERRING         | SPRING LOCKWASHER | RONDELLE GROWER    | ARANDELA ELASTICA  | A 16 DIN 128 A4C  |     |
| 14       | 231 1981  | 1          | BUEGEL            | YOKE/RETAINER     | ETRIER             | ESTRIBO            | B195, LINKS   |     |
| 15       | 231 1980  | 1          | BUEGEL            | YOKE/RETAINER     | ETRIER             | ESTRIBO            | B267, RECHTS  |     |
| 16       | 111 2693  | 4          | SECHSKANTSCHRAUBE | HEX-BOLT          | VIS 6 PANS         | TORNILLO HEXAGONAL | M16 X 45 DIN 933-M 8-8 A4C  |     |
| 17       | 230 1230  | 2          | BOLZEN            | PIN/BOLT/STUD     | BOULON/AXE         | BULON              |   |     |
| 21       | 110 7127  | 2          | SCHEIBE           | DISC/PANE/PLATE   | RONDELLE/DISQUE    | DISCO              | A23 DIN 125-ST-A4C  |     |
| 22       | 110 6499  | 1          | SPLINT            | SPLIT PIN         | GOUPILLE FENDUE    | PASADOR ALETAS     | 8 X 45 DIN 94-A4C   |     |
| 26       | 347 1270  | 1          | STECKBOLZEN       | COTTER PIN        | CHEVILLE           | BULON ENCHUFE      | 1941-11-32.10   |     |
| 27       | 110 7117  | 2          | SCHEIBE           | DISC/PANE/PLATE   | RONDELLE/DISQUE    | DISCO              | A17 DIN 125-ST-A4C  |     |
| 28       | 230 5312  | 1          | VERBINDUNGSSTANGE | CONNECTING ROD    | TRINGLE-RACCORD    | BARRA UNION        | B337, VOLLSTAENDIG  |     |
| 30       | 340 0220  | 1          | KLAPPSTECKER      | FOLDING PLUG      | FICHE PLIANTE      | CLAVIJA ARTICULADA | 1925-11-36.34   |     |
| 33       | 231 2108  | 1          | STANGE            | ROD/BAR           | BARRE/TIGE/TRINGLE | BARRA/VARILLA      | B337, VOLLSTAENDIG  |     |
| 34       | 233 3716  | 2          | KLAPPSTECKER      | FOLDING PLUG      | FICHE PLIANTE      | CLAVIJA ARTICULADA |   |     |
| 35       | 233 3054  | 1          | SPANNKETTE        | TENSIONING CHAIN  | CHAÎNE DE TENSION  | CADENA TENSORA     | B268, RECHTS-VOLLSTAENDIG<br>B050, BESTEM. AUS POS. 41, 44+45                 |     |
| 36       | 116 7052  | 2          | SCHEIBE           | DISC/PANE/PLATE   | RONDELLE/DISQUE    | DISCO              | 16, 5 X 31 X 7 H 995- 8-8   |     |
| 39       | 237 7485  | 2          | BOLZEN            | PIN/BOLT/STUD     | BOULON/AXE         | BULON              |   |     |

| Bad Nr. | Teil-Nr. | Stück-Zahl | Deutsch         | English         | Français       | Español         | Nummer/Bemerkung                          | ETK |
|---------|----------|------------|-----------------|-----------------|----------------|-----------------|---|-----|
| 41      | 233 3053 | 1          | KETTENENDE      | CHAIN/TRACK END | BOUT DE CHAINE | FINAL CADENA    | 0.173 M.<br>8195. LINKS                   |     |
| 42      | 232 0445 | 1          | KETTENENDE      | CHAIN/TRACK END | BOUT DE CHAINE | FINAL CADENA    | 1941-11-31.20<br>0.093 M.<br>8195. LINKS  |     |
| 43      | 347 1269 | 1          | KETTENENDE      | CHAIN/TRACK END | BOUT DE CHAINE | FINAL CADENA    | 1941-11-31.30<br>0.170 M.<br>8267. RECHTS |     |
| 44      | 233 3056 | 1          | KETTENENDE      | CHAIN/TRACK END | BOUT DE CHAINE | FINAL CADENA    | 0.093 M.<br>8267. RECHTS                  |     |
| 45      | 340 0601 | 2          | SPANNSCHLOSS    | TURNBUCKLE      | TENDEUR        | CIERRE TENSOR   | 1940-11-03-03                             |     |
| 51      | 238 9034 | 1          | ANHAENGESCHIENE | TOOLBAR         | BARRE ATTELAGE | CARRIL ENGANCHE | 8190. LANG                                |     |
| 52      | 340 0412 | 1          | ANHAENGESCHIENE | TOOLBAR         | BARRE ATTELAGE | CARRIL ENGANCHE | 1930-11-07.53<br>KURZ                     |     |



**DREIPUNKTKUPPLUNG  
THREE-POINT LINKAGE  
ATTELAGE TROIS POINTS  
SISTEMA DE ACOPLAMIENTO EN 3 PUNTOS**

7876/9320  
7868/0550

1926-11 502 0155

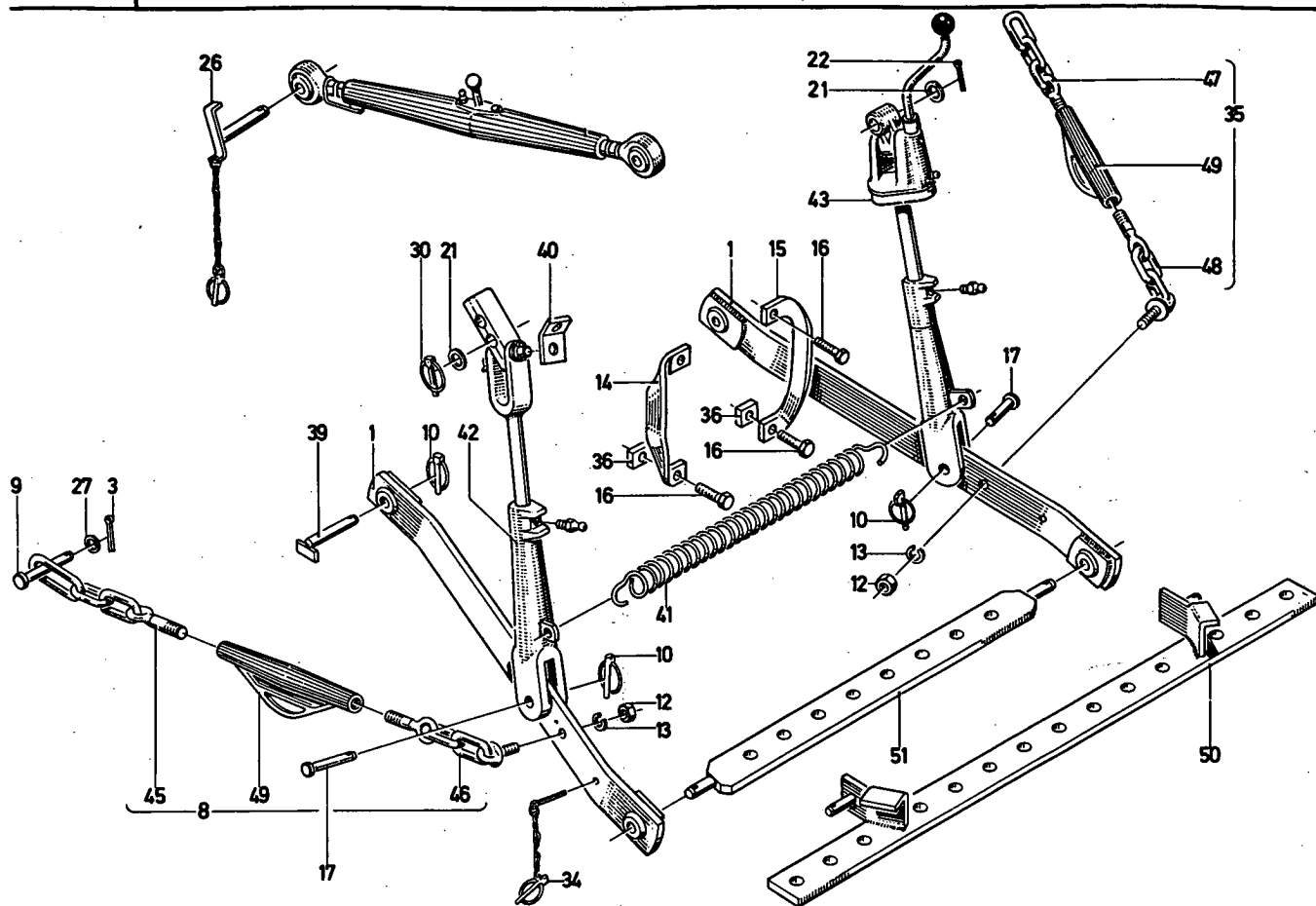

| Bild Nr. | Teil-Nr. | Stück-Zahl | Deutsch           | English           | Français           | Español            | 1926-11 502 0155<br>Nummer/Bemerkung                        | ETK |
|----------|----------|------------|-------------------|-------------------|--------------------|--------------------|---|-----|
| 1        | 230 1355 | 2          | UNTERER-LENKER    | BOTTOM LINK       | BRAS INFÉRIEUR     | GUÍA INFERIOR      |   |     |
| 3        | 110 6468 | 2          | SPLINT            | SPLIT PIN         | GOUPILLE FENDUE    | PASADOR ALETAS     | 5 X 30DIN 74 VZKC   |     |
| 8        | 347 1268 | 1          | SPANNKETTE        | TENSIONING CHAIN  | CHAÎNE DE TENSION  | CADENA TENSORA     | 1941-11-31-10<br>8195-LINKS<br>8050-BESTEH-AUS POS.45.46+49 |     |
| 9        | 340 0835 | 2          | BOLZEN            | PIN/BOLT/STUD     | BOULON/AXE         | BULON              | 1941-11-10-15   |     |
| 10       | 340 0205 | 4          | KLAPPSTECKER      | FOLDING PLUG      | FICHE PLIANTE      | CLAVIJA ARTICULADA | 1925-11-29-31   |     |
| 12       | 111 2884 | 2          | SECHSKANTMUTTER   | HEX-NUT           | ECROU 6 PANS       | TUERCA HEXAGONAL   | M 16 DIN 934 M 8 A4C 934-M 8                                |     |
| 13       | 110 7242 | 2          | FEDERRING         | SPRING LOCKWASHER | RONDELLE GROMER    | ARANDELA ELASTICA  | 816 DIN 127 VZKC  |     |
| 14       | 231 1961 | 1          | STABILISIERUNG    | STABILIZATION     | STABILISATION      | ESTABILIZACION     |   |     |
| 15       | 231 1960 | 1          | STABILISIERUNG    | STABILIZATION     | STABILISATION      | ESTABILIZACION     |   |     |
| 16       | 111 2673 | 4          | SECHSKANTSCHRAUBE | HEX-BOLT          | VIS 6 PANS         | TORNILLO HEXAGONAL | M16X45 DIN 933-M8-8-A4C                                     |     |
| 17       | 230 1230 | 2          | BOLZEN            | PIN/BOLT/STUD     | BOULON/AXE         | BULON              |   |     |
| 21       | 110 7127 | 1          | SCHEIBE           | DISC/PANE/PLATE   | RONDELLE/DISQUE    | DISCO              | A23 DIN125-ST-A4C   |     |
| 22       | 110 6477 | 1          | SPLINT            | SPLIT PIN         | GOUPILLE FENDUE    | PASADOR ALETAS     | 8 X 45DIN 74 VZKC   |     |
| 26       | 347 1270 | 1          | STECKBOLZEN       | COTTER PIN        | CHEVILLE           | BULON ENCHUFE      | 1941-11-32-10   |     |
| 27       | 110 7117 | 2          | SCHEIBE           | DISC/PANE/PLATE   | RONDELLE/DISQUE    | DISCO              | A17 DIN 125-ST-A4C  |     |
| 30       | 340 0220 | 1          | KLAPPSTECKER      | FOLDING PLUG      | FICHE PLIANTE      | CLAVIJA ARTICULADA | 1925-11-36-34   |     |
| 34       | 233 3716 | 2          | KLAPPSTECKER      | FOLDING PLUG      | FICHE PLIANTE      | CLAVIJA ARTICULADA |   |     |
| 35       | 233 3054 | 1          | SPANNKETTE        | TENSIONING CHAIN  | CHAÎNE DE TENSION  | CADENA TENSORA     | 8267-RECHTS<br>8050-BESTEH-AUS POS.47.48+49                 |     |
| 36       | 116 7052 | 2          | SCHEIBE           | DISC/PANE/PLATE   | RONDELLE/DISQUE    | DISCO              | 16.5X31X7 H 795-8-8   |     |
| 39       | 237 7485 | 2          | BOLZEN            | PIN/BOLT/STUD     | BOULON/AXE         | BULON              |   |     |
| 40       | 238 2905 | 1          | HALTER            | RETAINER          | SUPPORT/PORTERUTIL | SOPORTE            |   |     |
| 41       | 238 0723 | 1          | ZUGFEDER          | DRUM SPRING       | RESSORT TRACTION   | RESORTE TRACCION   |   |     |
| 42       | 238 4315 | 1          | VERBINDUNGSSTANGE | CONNECTING ROD    | TRINGLE-RACCORD    | BARRA UNION        | 8313-TEILENUMMERN-LISTENBLATT<br>1952-11 502 0156           |     |

| Bld<br>Nr. | Teil-Nr. | Stück-<br>Zahl | 1926-11 502 0155 |                 |                  |                 | Nummer/Bemerkung                                  | ETK |
|------------|----------|----------------|------------------|-----------------|------------------|-----------------|---|-----|
|            |          |                | Deutsch          | English         | Français         | Español         |   |     |
| 43         | 238 4366 | 1              | MIBSTANGE        | LIFTRÖD         | CHANDELLE        | BARRA ELEVACION | 8313-TEILENUMMERN-LISTENBLATT<br>1926-11 502 0157 |     |
| 45         | 347 1269 | 1              | KETTENENDE       | CHAIN/TRACK END | BOUT DE CHAINE   | FINAL CADENA    | 1941-11-31-30<br>0.170 N<br>8267-RECHTS           |     |
| 46         | 232 0945 | 1              | KETTENENDE       | CHAIN/TRACK END | BOUT DE CHAINE   | FINAL CADENA    | 1941-11-31-20<br>0.090 N<br>8195-LINKS            |     |
| 47         | 233 3053 | 1              | KETTENENDE       | CHAIN/TRACK END | BOUT DE CHAINE   | FINAL CADENA    | 0.170 N<br>8195-LINKS                             |     |
| 48         | 233 3056 | 1              | KETTENSCHRAUBE   | CHAIN SCREW     | BOULON DE CHAINE | TORNILLO CADENA | 0.090 N<br>8267-RECHTS                            |     |
| 49         | 340 0603 | 1              | SPANNSCHLOSS     | TURNBUCKLE      | TENDEUR          | CIERRE TENSOR   | 1940-11-03-01                                     |     |
| 50         | 238 4034 | 1              | ANHAENGESCHIENE  | TOOLBAR         | BARRE ATTELAGE   | CARRIL ENGANCHE |   |     |
| 51         | 340 0412 | 1              | ANHAENGESCHIENE  | TOOLBAR         | BARRE ATTELAGE   | CARRIL ENGANCHE |   |     |



**DREI-PUNKTKUPPLUNG - NACHRÜSTSATZ**  
**THREE-POINT LINKAGE - SPECIAL - PURPOSE - CONVERSION KIT**  
**ATTELAGE TOIS POINTS - KIT D'APPLICATION PARTICULIERE**  
**SISTEMA DE ACOPLAMIENTO EN 3 PUNTOS - EQUIPE P. APLICACION ESPECIAL**

1952-11 502 0154

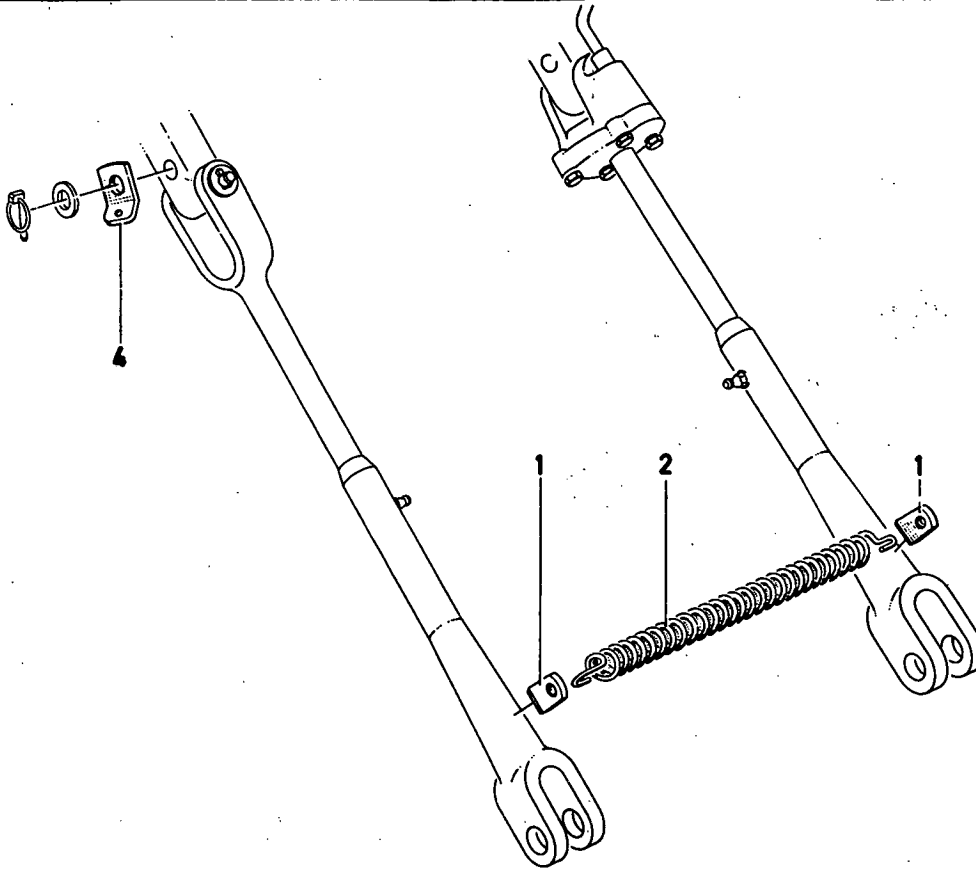

| Bild-Nr. | Teil-Nr. | Stück-Zahl | Deutsch  | English     | Français           | Español          | 1952-11 502 0154<br>Nummer/Bemerkung | ETK |
|----------|----------|------------|----------|-------------|--------------------|------------------|--------------------------------------|-----|
| 1        | 238 2887 | 2          | BUTZEN   | BOSS        | BOSSAGE/TETON      | MUNON            |                                      |     |
| 2        | 238 0723 | 1          | ZUGFEDER | DRAW-SPRING | RESSORT TRACTION   | RESORTE TRACCION |                                      |     |
| 3        | 238 2905 | 1          | HALTER   | RETAINER    | SUPPORT/PORTE-UTIL | SOPORTE          |                                      |     |

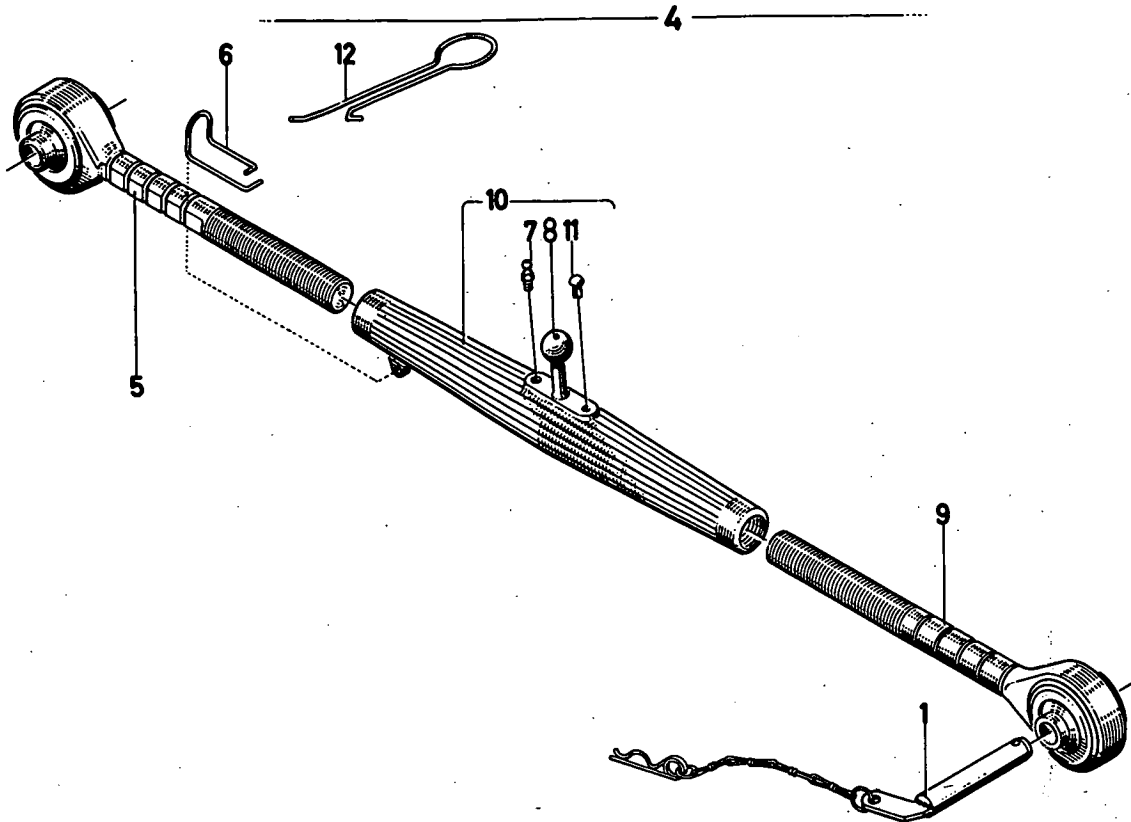

| Bild Nr. | Teil-Nr. | Stück-Zahl | Deutsch            | English      | Français          | Español           | Nummer/Bemerkung    | ETK |
|----------|----------|------------|--------------------|--------------|-------------------|-------------------|---------------------|-----|
| 1        | 339 9777 | 1          | STECKBOLZEN        | COTTER PIN   | CHEVILLE          | BULON ENCHUFE     | 1911-11-08-10       |     |
| 4        | 231 2241 | 1          | OBERER-LENKER      | TOP LINK     | BRAS SUPERIEUR    | GUIA SUPERIOR     |                     |     |
| 5        | 231 4795 | 1          | BRUCKSTANGE        | THRUST ROD   | BRAS DE LEVIER    | VARILLA PRESION   |                     |     |
| 6        | 231 2246 | 1          | BUEGELFEDER        | YOKE SPRING  | ETRIER-RESSORT    | RESORTE ESTRIBO   |                     |     |
| 7        | 116 8224 | 1          | KEGELSCHNIERNIPPEL | LUBE FITTING | GRAISSEUR CONIQUE | ENGRASADOR CONICO | SA 6H 3360          |     |
| 8        | 331 4857 | 1          | GRIFP              | HANDLE       | POIGNER-MANETTE   | PUNO/ASA          | 1926-11-29-20       |     |
| 9        | 390 0343 | 1          | BRUCKSTANGE        | THRUST ROD   | BRAS DE LEVIER    | VARILLA PRESION   | 8196-LINKSGEWINDE   |     |
| 10       | 231 4848 | 1          | SPANNSCHLOSS       | TURNBUCKLE   | TENDEUR           | CIERRE TENSOR     |                     |     |
| 11       | 110 1300 | 1          | HALBRUNDKERBNAGEL  | NOTCHED NAIL | ERGOT A ENCOCHE   | CLAVIJA RANURADA  | 7X10 DIN 1476, VZKC |     |
| 12       | 230 9807 | 1          | FEDERBUEGEL        | SPRING CLAMP | ETRIER DE RESSORT | ESTRIBO RESORTE   |                     |     |



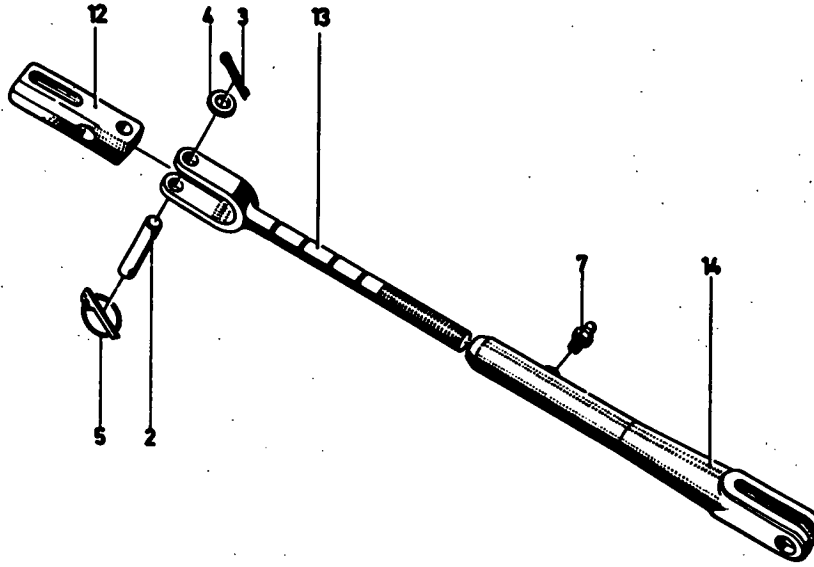

1952-11 500 6242

| Bild Nr. | Teil-Nr. | Stück-Zahl | Deutsch            | English         | Français           | Español            | Nummer/Bemerkung       | ETK |
|----------|----------|------------|--------------------|-----------------|--------------------|--------------------|------------------------|-----|
| 2        | 340 1442 | 1          | BOLZEN             | PIN/BOLT/STUD   | BOULON/AXE         | BULON              | 1952-11-03-02          |     |
| 3        | 110 6466 | 1          | SPLINT             | SPLIT PIN       | GOUILLE FENDUE     | PASADOR ALETAS     | 5 X 30DIN 94-A4C       |     |
| 4        | 110 7121 | 1          | SCHEIBE            | DISC/PANE/PLATE | RONDELLE/DISQUE    | DISCO              | A19 DIN 125-ST-A4C     |     |
| 5        | 112 5312 | 1          | KLAPPSTECKER       | FOLDING PLUG    | FICHE PLIANTE      | CLAVIJA ARTICULADA | 5 DIN11023-ST5C-2 VZKC |     |
| 7        | 116 8224 | 1          | KEGELSCHMIERNIPPEL | LUBE FITTING    | GRAISSEUR CONIQUE  | ENGRASADOR CONICO  | SA 6H 3360             |     |
| 12       | 230 5306 | 1          | GELENKKOPF         | JOINT FITTING   | TETE D ARTICULAT   | CBZA-ARTICULACION  | 1952-11-03-01          |     |
| 13       | 230 5301 | 1          | STANGE             | ROD/BAR         | BARRE/TIGE/TRINGLE | BARRA/VARILLA      |                        |     |
| 14       | 233 5334 | 1          | GABELKOPF          | CLEVIS          | CHAPE              | CABEZA FORQUILLA   |                        |     |



VERBINDUNGSSTANGE  
CONNECTING ROD  
CHANDELLE  
BARRA DE ELEVACION

7876/9320  
7868/0550

1952-11 502 0156

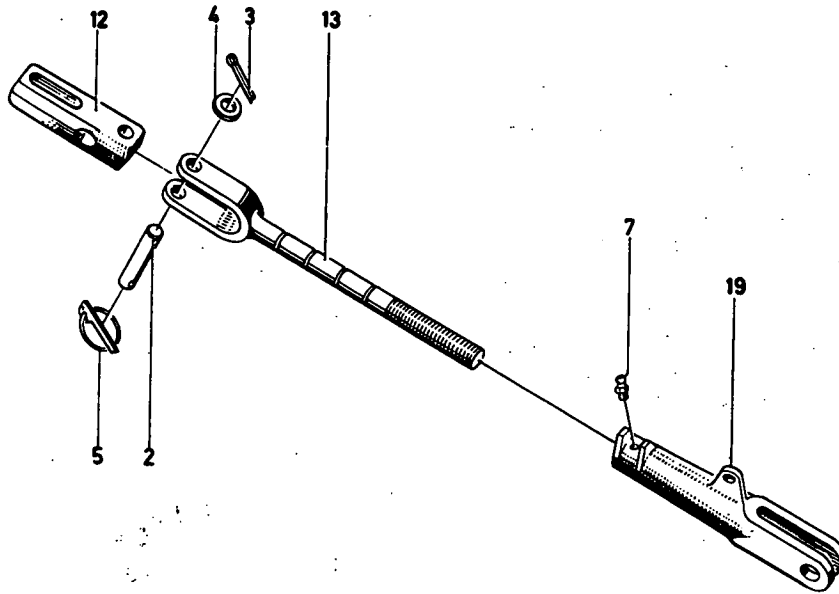

| Bild<br>Nr. | Teil-Nr. | Stück-<br>Zahl | 1952-11 502 0156   |                 |                   |                    | Nummer/Bemerkung        | ETK |
|-------------|----------|----------------|--------------------|-----------------|-------------------|--------------------|-------------------------|-----|
|             |          |                | Deutsch            | English         | Français          | Español            |                         |     |
| 2           | 340 1442 | 1              | BOLZEN             | PIN/BOLT/STUD   | BOULON/AXE        | BULON              | 1952-11-03-02           |     |
| 3           | 110 6468 | 1              | SPLINT             | SPLIT PIN       | GOUPILLE FENDUE   | PASADOR ALETAS     | 5 X 30 DIN 94 VZKC      |     |
| 4           | 110 7121 | 1              | SCHEIBE            | DISC/PANE/PLATE | RONDELLE/DISQUE   | DISCO              | 19 DIN 125-A4C          |     |
| 5           | 112 5312 | 1              | KLAPPSTECKER       | FOLDING PLUG    | FICHE PLIANTE     | CLAVIJA ARTICULADA | 5 DIN 11023-ST50-2 VZKC |     |
| 7           | 116 8224 | 1              | KEGELSCHMIERNIPPEL | LUBE FITTING    | GRAISSEUR CONIQUE | ENGRASADOR CONICO  | SA 6H 3360              |     |
| 12          | 230 5306 | 1              | GELENKKOPF         | JOINT FITTING   | TETE D ARTICULAT  | COZA-ARTICULACION  |                         |     |
| 13          | 230 5303 | 1              | HUBSTANGE          | LIFTRÖD         | CHANDELLE         | BARRA ELEVACION    |                         |     |
| 19          | 238 2881 | 1              | GABELKOPF          | CLEVIS          | CHAPE             | CABEZA HORQUILLA   |                         |     |

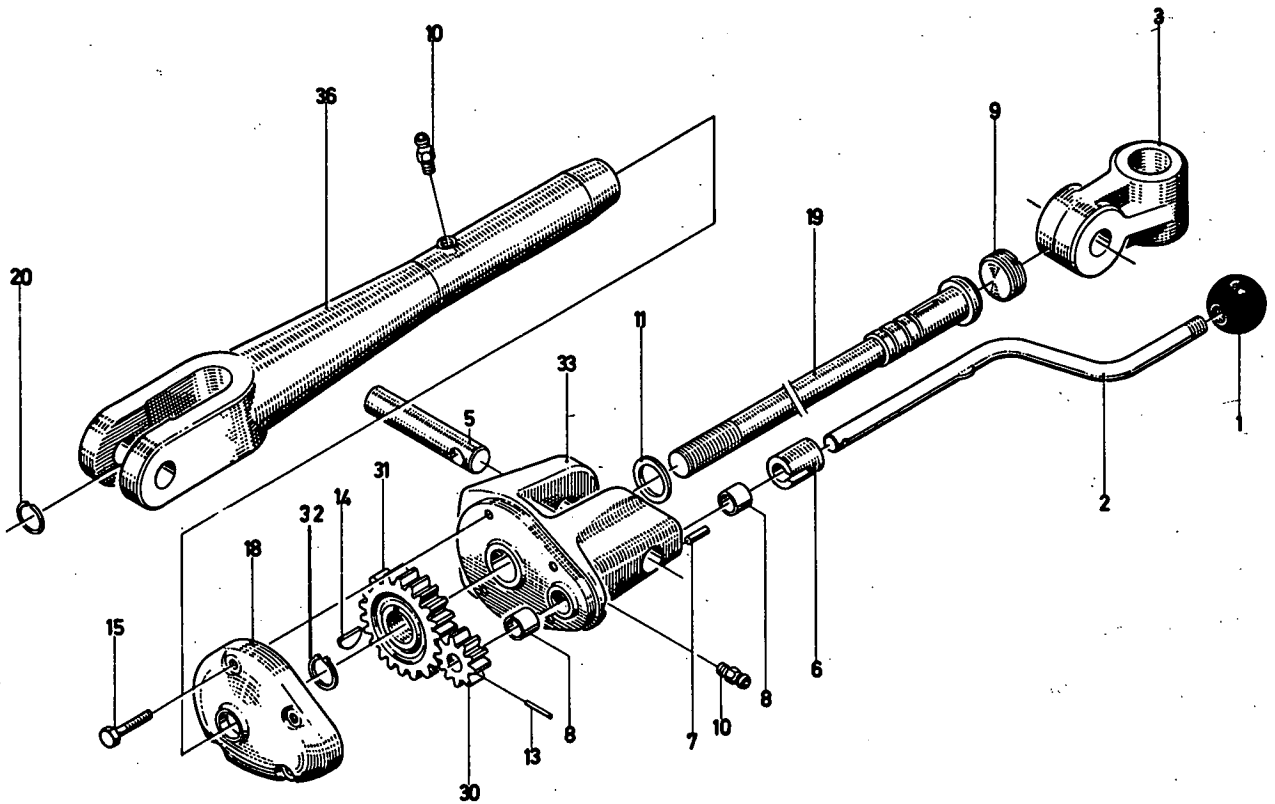

1926-11 500 5130

| Bild Nr. | Teil-Nr. | Stück-Zahl | Deutsch            | English            | Francés            | Español            | Nummer/Bemerkung            | ETK |
|----------|----------|------------|--------------------|--------------------|--------------------|--------------------|-----------------------------|-----|
| 1        | 116 2420 | 1          | KUGELKOPF          | BALL HEAD          | TETE SPHERIQUE     | CABEZA ESFERICA    | B32X12H 3517 PRESSTOFF MATT |     |
| 2        | 230 1363 | 1          | KURBEL             | CRANK/HANDLE       | MANIVELLE          | MANIVELA/MANUBRIO  |                             |     |
| 3        | 231 2113 | 1          | GELENKKOPF         | JOINT FITTING      | TETE D ARTICULAT   | CEZA-ARTICULACION  |                             |     |
| 5        | 231 2276 | 1          | BOLZEN             | PIN/BOLT/STUD      | BOLON/AXE          | BULON              |                             |     |
| 6        | 231 2112 | 1          | SICHERUNG          | FUSE/LOCK          | FUSIBLE/COUPE-CIRC | SEGURO/FUSIBLE     |                             |     |
| 7        | 112 5057 | 1          | SPANNHUELSE        | DOWEL SLEEVE       | DOUILLE SERRAGE    | CASQUILLO FIADOR   | 5 X 16DIN 1481 VZKC         |     |
| 8        | 230 1362 | 2          | LAGERBUCHSE        | BEARING BUSH       | BAGUE DE PALIER    | CASQU-COJINETE     |                             |     |
| 9        | 116 5799 | 1          | SCHLITZSTOPFEN     | SLOTTED PLUG       | BOUCHON FENDU      | TAPON RANURADO     | M40X1,5 H 710 VZKC          |     |
| 10       | 116 8224 | 2          | KEGELSCHMIERNIPPEL | LUBE FITTING       | GRAISSEUR CONIQUE  | ENGRASADOR CONICO  | SA 6H 3360                  |     |
| 11       | 230 1365 | 1          | GLEITSCHWEIBE      | DISC/PANE/DIAL/CUT | DISQUE DE GLISSEM  | ARANDELA DESLIZ-   |                             |     |
| 13       | 111 5416 | 1          | SPANNHUELSE        | DOWEL SLEEVE       | DOUILLE SERRAGE    | CASQUILLO FIADOR   | 4 X 16DIN 1481              |     |
| 14       | 111 8325 | 1          | SCHWEIBENFEDER     | WOODRUFF KEY       | CLAVETTE WOODRUFF  | CHAVETA MEDIA LUNA | 4 X 5 DIN 6888              |     |
| 15       | 111 1071 | 2          | SECHSKANTSCHRAUBE  | HEX-BOLT           | VIS 6 PANS         | TORNILLO HEXAGONAL | M 6X 40 DIN 931- 8-8-A4C    |     |
| 16       | 230 1364 | 1          | DECKEL             | COVER              | COUVERCLE          | TAPA               |                             |     |
| 17       | 231 2111 | 1          | STANGE             | ROD/BAR            | BARRE/TIGE/TRINGLE | BARRA/VARILLA      |                             |     |
| 20       | 111 9827 | 1          | SPRENGRING         | SNAP RING          | AGRAFE CIRCULAIRE  | ANILLO RETENCION   | 20DIN 9045                  |     |
| 30       | 231 9173 | 1          | ZAHNRAD            | GEAR               | ROUE DENTEE        | RUEDA DENTADA      | Z 10                        |     |
| 31       | 231 9175 | 1          | ZAHNRAD            | GEAR               | ROUE DENTEE        | RUEDA DENTADA      |                             |     |
| 32       | 110 7732 | 1          | SICHERUNGSRING     | CIRCLIP            | CIRCLIP            | CIRCLIP            | 22X1,2 DIN 471              |     |
| 33       | 232 2287 | 1          | LAGER              | BEARING/SUPPORT    | PALIER/SUPPORT     | SOPORTE/COJINETE   |                             |     |
| 36       | 233 5333 | 1          | GABELKOPF          | CLEVIS             | CHAPE              | CABEZA FORQUILLA   |                             |     |

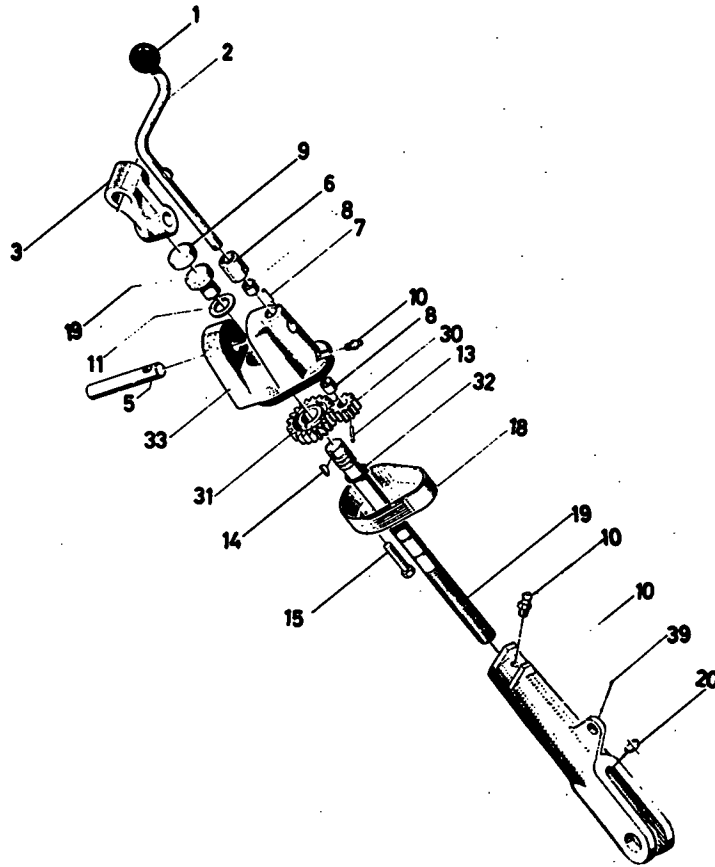

| Bild Nr. | Teil-Nr. | Stück-Zahl | Deutsch            | English            | Français           | Español            | 1926-11 502 0157<br>Nummer / Bemerkung | ETK |
|----------|----------|------------|--------------------|--------------------|--------------------|--------------------|--|-----|
| 1        | 116 2920 | 1          | KUGELKOPF          | BALL HEAD          | TETE SPHERIQUE     | CABEZA ESFERICA    | 832X12H 3517 PRESSSTOFF NATT.          |     |
| 2        | 230 1363 | 1          | KURBEL             | CRANK/HANDLE       | MANIVELLE          | MANIVELA/MANUBRIO  |  |     |
| 3        | 231 2113 | 1          | GELENKKOPF         | JOINT FITTING      | TETE D ARTICULAT   | COZA-ARTICULACION  |  |     |
| 5        | 231 2276 | 1          | BOLZEN             | PIN/BOLT/STUD      | BOULON/AXE         | BULON              |  |     |
| 6        | 231 2112 | 1          | SICHERUNG          | FUSE/LOCK          | FUSIBLE/COUPE-CIRC | SEGURO/FUSIBLE     |  |     |
| 7        | 111 5252 | 1          | STECKERBSTIFT      | END-NOTCHED PIN    | GOUPILLE ENTAILLEE | CLAVIJA RANURADA   | 5X 16DIN 1474 VZKC                     |     |
| 8        | 230 1362 | 2          | LAGERBUCHSE        | BEARING BUSH       | BAGUE DE PALIER    | CASQU-COJINETE     |  |     |
| 9        | 116 5777 | 1          | SCHLITZSTOPFEN     | SLOTTED PLUG       | BOUCHON FENDU      | TAPON RANURADO     | M40X1,5 H 710 VZKC                     |     |
| 10       | 116 6224 | 2          | KEGELSCHNIERNIPPEL | LUBE FITTING       | GRAISSEUR CONIQUE  | ENGRASADOR CONICO  | SA 6H 3360                             |     |
| 11       | 230 1365 | 1          | GLEITSCHEIBE       | DISC/PANE/DIAL/CUT | DISQUE DE GLISSEH  | ARANDELA DESLIZ.   |  |     |
| 13       | 111 5418 | 1          | SPANNHUELSE        | BOWL SLEEVE        | DOUILLE SERRAGE    | CASQUILLO FIADOR   | 4 X 18DIN 1481                         |     |
| 14       | 111 6325 | 1          | SCHWEIBENFEDER     | WOODRUFF KEY       | CLAVETTE WOODRUFF  | CHAVETA MEDIA LUNA | 4 X 5 DIN 6888                         |     |
| 15       | 111 1071 | 2          | SECHSKANTSCHRAUBE  | HEX-BOLT           | VIS 6 PANS         | TORNILLO HEXAGONAL | M 6X 40 DIN 931- 8-8-A4C               |     |
| 16       | 230 1364 | 1          | BECKEL             | COVER              | COUVERCLE          | TAPA               |  |     |
| 17       | 231 2111 | 1          | HUBSTANGE          | LIFTROD            | CHANDELLE          | BARRA ELEVACION    |  |     |
| 20       | 111 9827 | 1          | SPRENGRING         | SNAP RING          | AGRAFE CIRCULAIRE  | ANILLO RETENCION   | 20DIN 9045                             |     |
| 30       | 231 9173 | 1          | ZAHNRAD            | GEAR               | ROUE DENTEE        | RUEDA DENTADA      | 2 10                                   |     |
| 31       | 231 9175 | 1          | ZAHNRAD            | GEAR               | ROUE DENTEE        | RUEDA DENTADA      |  |     |
| 32       | 110 7732 | 1          | SICHERUNGSRING     | CIRCLIP            | CIRCLIP            | CIRCLIP            | 22X1,2 DIN 471                         |     |
| 33       | 232 2287 | 1          | GABEL              | CLEVIS/FORK        | FOURCHETTE         | MORQUILLA          |  |     |
| 37       | 238 2881 | 1          | GABELKOPF          | CLEVIS             | CHAPE              | CABEZA MORQUILLA   |  |     |



ZUGPENDEL  
DRAWBAR  
BARRE OSCILLANTE  
PENDULO DE TRACCION

1941-14 500 4255

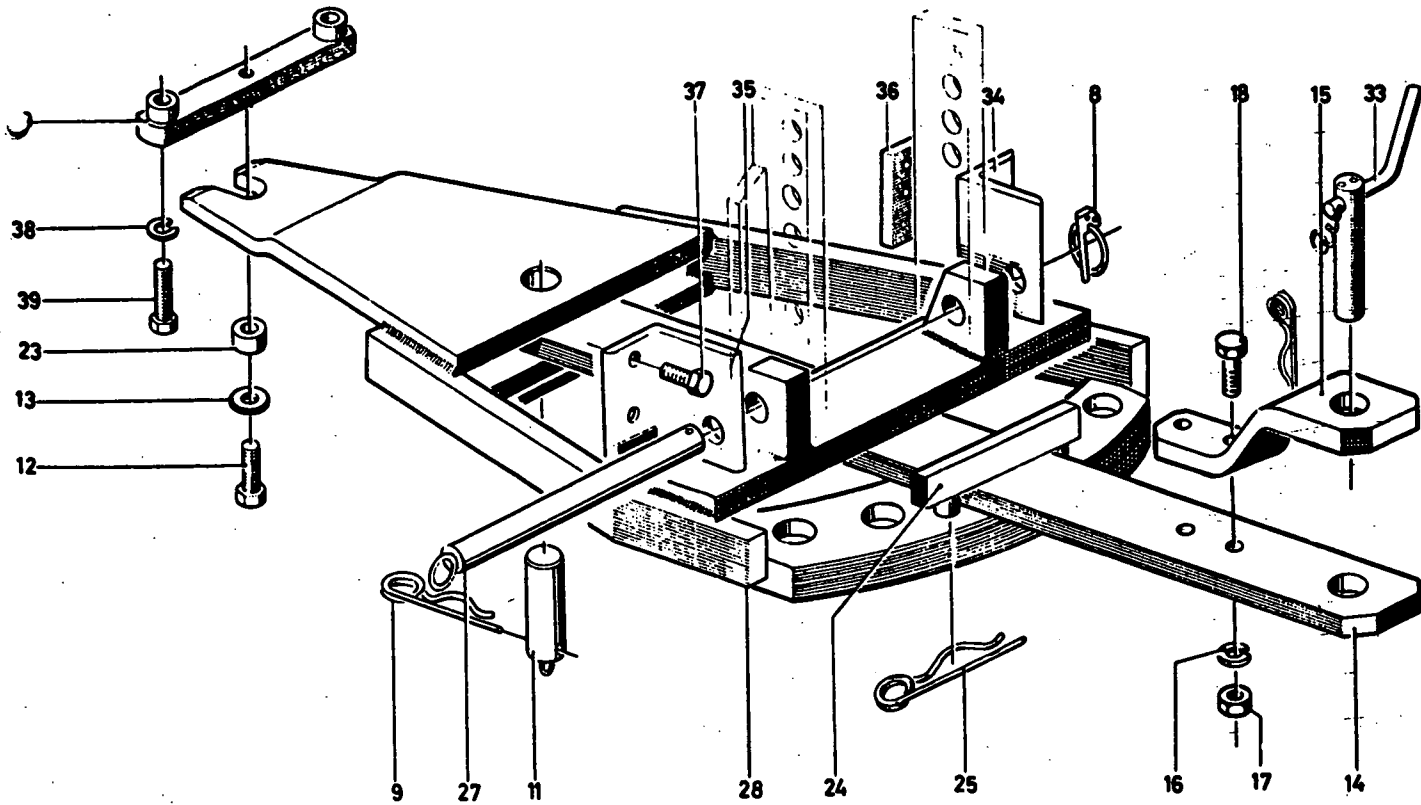

1941-14 500 4255

| Bild-Nr. | Teil-Nr. | Stück-Zahl | Deutsch           | English           | Français          | Español            | Nummer/Bemerkung                   | ETK |
|----------|----------|------------|-------------------|-------------------|-------------------|--------------------|------------------------------------|-----|
| 8        | 340 0220 | 1          | KLAPPSTECKER      | FOLDING-PLUG      | FICHE PLIANTE     | CLAVIJA ARTICULADA | 1725-11-36-34                      |     |
| 9        | 340 1061 | 1          | SICHERUNGSSTIFT   | LOCKING-PIN       | GOUPILLE D'ARRET  | PERNO AFIANZADOR   | 1745-14-01-25                      |     |
| 11       | 340 0871 | 1          | BOLZEN            | PIN/BOLT/STUD     | BOULON/AXE        | BULON              | 1741-14-22-10                      |     |
| 12       | 111 2693 | 1          | SECHSKANTSCHRAUBE | HEX-BOLT          | VIS 6 PANS        | TORNILLO HEXAGONAL | M16X 95 DIN 933-M 8.8 A9C          |     |
| 13       | 340 0865 | 1          | SCHIEBE           | DISC/PANE/PLATE   | RONDELLE/DISQUE   | DISCO              | 1741-14-05-13                      |     |
| 14       | 340 0866 | 1          | ZUGSTREBE         | BRACE/STRUT       | CONTREPICHE       | TIRANTE            | 1741-14-05-14                      |     |
| 16       | 340 0867 | 1          | FUEHRUNGSBLECH    | GUIDE-PLATE       | TOLE DE GUIDAGE   | CHAPA GUIA         | 1741-14-05-15                      |     |
| 17       | 110 2804 | 2          | FEDERING          | SPRING-LOCKWASHER | RONDELLE GROMER   | ARANDELA ELASTICA  | A 18 DIN 128-A9C                   |     |
| 18       | 111 2708 | 2          | SECHSKANTMUTTER   | HEX-NUT           | ECROU 6 PANS      | TUERCA HEXAGONAL   | M16 X2 DIN 934-M 8.8 VZKC          |     |
| 23       | 111 3777 | 2          | SECHSKANTSCHRAUBE | HEX-BOLT          | VIS 6 PANS        | TORNILLO HEXAGONAL | M16X2 X 55 DIN 950-M 8.8 VZKC      |     |
| 24       | 340 0874 | 1          | ANSCHRAUBLEISTE   | FASTENING RAIL    | LISTEAU A VISSER  | LISTON PIZAC.      | 1741-14-25-10<br>B337-VOLLSTAENDIG |     |
| 25       | 340 0869 | 1          | HUELSE            | SLEEVE            | DOUILLE           | CASQUILLO          | 1741-14-05-23                      |     |
| 27       | 230 6292 | 1          | BOLZEN            | PIN/BOLT/STUD     | BOULON/AXE        | BULON              |                                    |     |
| 28       | 338 7615 | 2          | SICHERUNGSSTIFT   | LOCKING PIN       | GOUPILLE D'ARRET  | PERNO AFIANZADOR   | 1124-63-01-11                      |     |
| 29       | 231 7951 | 1          | STECKBOLZEN       | COTTER-PIN        | CHEVILLE          | BULON ENCHUFE      |                                    |     |
| 33       | 231 7953 | 1          | RAHMEN            | FRAME             | CHASSIS/CADRE     | BASTIDOR/MARCO     |                                    |     |
| 34       | 340 1804 | 1          | VORSTECKBOLZEN    | COTTER/HITCH-PIN  | BROCHE            | PERNO ENGANCHE     | 1773-14-32-10                      |     |
| 35       | 233 7914 | 1          | WINKEL            | ANGLE-PLATE       | EQUERRE           | ANGULO             | B267-RECHTS                        |     |
| 36       | 233 7915 | 1          | WINKEL            | ANGLE PLATE       | EQUERRE           | ANGULO             | B195-LINKS                         |     |
| 37       | 237 5329 | 2          | ZWISCHENBLECH     | SHIM              | TOLE INTERCALAIRE | CHAPA INTERMEDIA   |                                    |     |
| 38       | 111 2679 | 4          | SECHSKANTSCHRAUBE | HEX-BOLT          | VIS 6 PANS        | TORNILLO HEXAGONAL | M16X 35 DIN 933-M 8.8 A9C          |     |
| 39       | 110 2802 | 2          | FEDERING          | SPRING-LOCKWASHER | RONDELLE GROMER   | ARANDELA ELASTICA  | A 14 DIN 128 A9C                   |     |
| 39       | 112 2458 | 2          | SECHSKANTSCHRAUBE | HEX-BOLT          | VIS 6 PANS        | TORNILLO HEXAGONAL | M14X 55 DIN 933-M 8.8 A9C          |     |

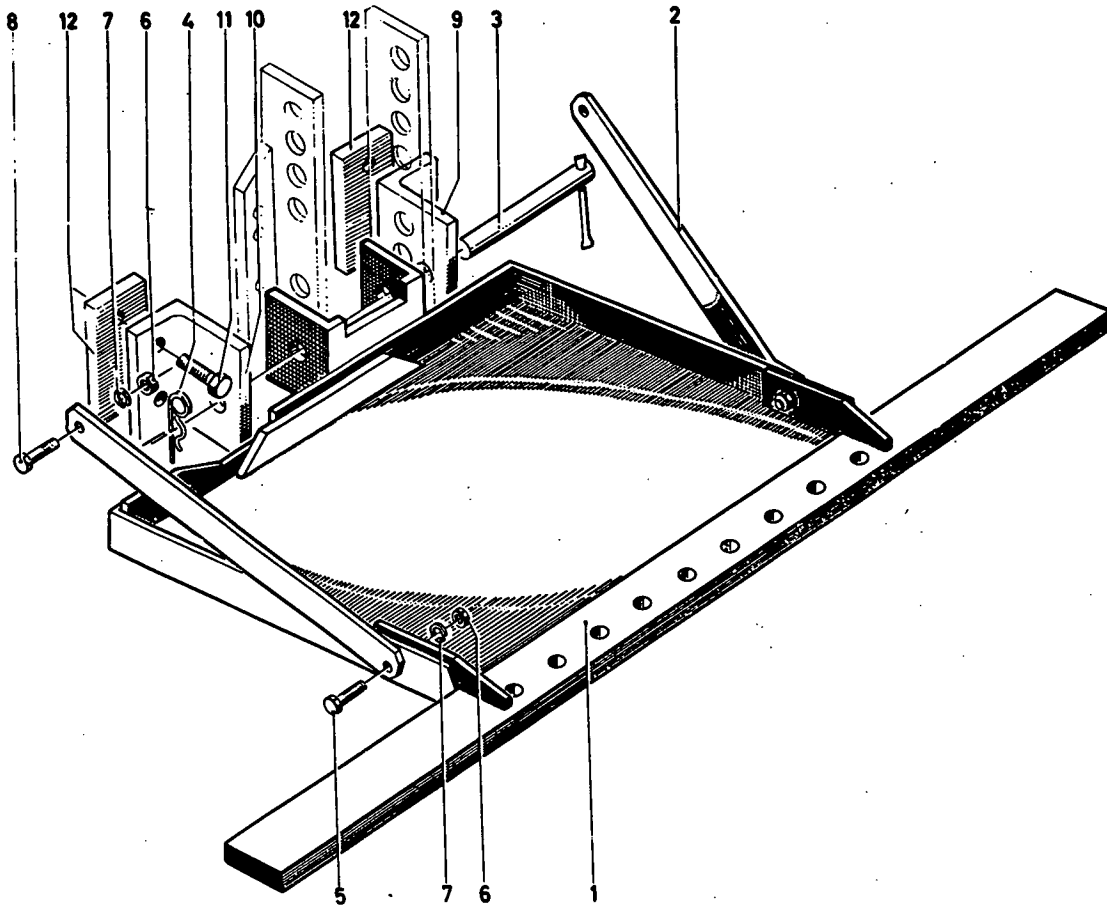

1926-15 500 4256

| Bild Nr. | Teile-Nr. | Stück-Zahl | Deutsch           | English           | Français            | Español            | Nummer/Bemerkung  | ETK |
|----------|-----------|------------|-------------------|-------------------|---------------------|--------------------|---|-----|
| 1        | 340 0254  | 1          | ANHAENGEVORRICHTG | HITCH ASSY        | DISPOSITIF ATTELAGE | DISPOS-ENGANCHE    | 1926-15-02-10   |     |
| 2        | 340 0342  | 2          | STREBE            | BRACE/STRUT       | JAMBE DE FORCE      | TIRANTE            | 1926-15-01-02   |     |
| 3        | 334 4440  | 1          | STECKBOLZEN       | COTTER PIN        | CHEVILLE            | BULON ENCHUFE      | 1924-15-01-05   |     |
| 4        | 338 7614  | 1          | SICHERUNGSTIFT    | LOCKING PIN       | GOUPILLE D'ARRET    | PERNO AFIANZADOR   | 1124-63-01-07   |     |
| 5        | 111 2631  | 2          | SECHSKANTSCHRAUBE | HEX-BOLT          | VIS 6 PANS          | TORNILLO HEXAGONAL | M14 X 45 DIN 933-M 8-8 A4C  |     |
| 6        | 111 2674  | 4          | SECHSKANTMUTTER   | HEX-NUT           | ECROU 6 PANS        | TUERCA HEXAGONAL   | M14 DIN 934-M 8 A4C   |     |
| 7        | 110 2802  | 4          | FEDERRING         | SPRING LOCKWASHER | RONDELLE GROMER     | ARANDELA ELASTICA  | A 14 DIN 128 A4C  |     |
| 8        | 111 1673  | 8          | SECHSKANTSCHRAUBE | HEX-BOLT          | VIS 6 PANS          | TORNILLO HEXAGONAL | M14 X 60 DIN 933-M 8-8 A4C  |     |
| 9        | 233 4914  | 1          | WINKEL            | ANGLE PLATE       | EQUERRE             | ANGULO             | 8267, RECHTS 8236, NUR BEI KURZER FUEHRUNGSSCHIENE                  |     |
| 10       | 233 4915  | 1          | WINKEL            | ANGLE PLATE       | EQUERRE             | ANGULO             | 8195, LINKS 8236, NUR BEI KURZER FUEHRUNGSSCHIENE                   |     |
| 11       | 111 2674  | 4          | ZWISCHENBLECH     | SHIM              | TOLE INTERCALAIRE   | CHAPA INTERMEDIA   | M16 X 40 DIN 933-M 8-8 A4C<br>8236, NUR BEI KURZER FUEHRUNGSSCHIENE |     |
| 12       | 237 5324  | 2          | BLECH             | PLATE             | TOLE                | CHAPA              | 0171-37-001-014<br>8236 NUR BEI KURZER FUEHRUNGSSCHIENE             |     |



DEUTZ - HITCH  
 DEUTZ - HITCH  
 PICK-HUP DEUTZ  
 ENGANCHE HIDRAULICO

1952-17 500 6319

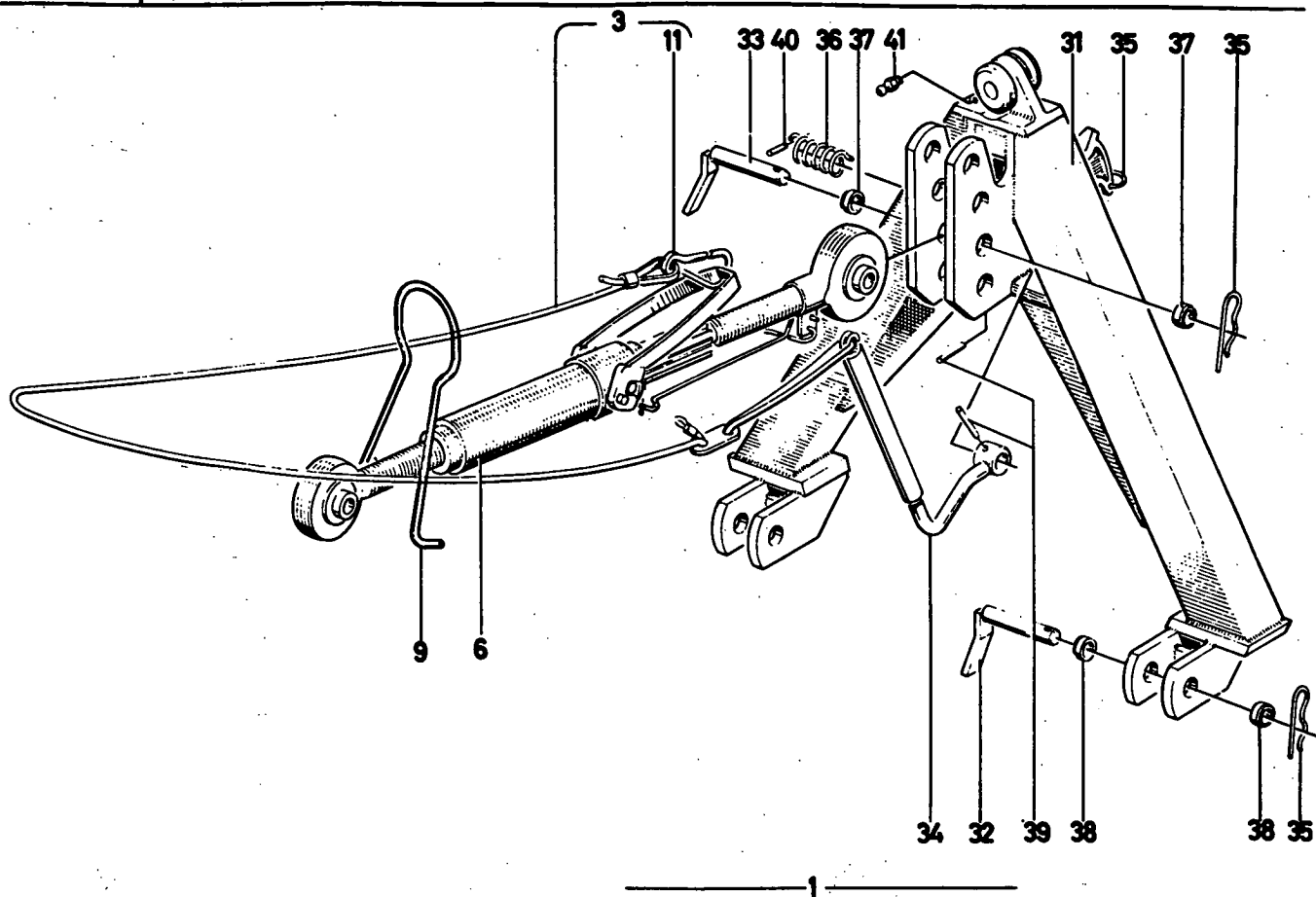

| Bld. Nr. | Teile-Nr. | Stück-Zahl | Deutsch         | English       | Francés            | Español           | Nummer/Bemerkung                     | ETK |
|----------|-----------|------------|-----------------|---------------|--------------------|-------------------|--------------------------------------|-----|
| 1        | 237 1074  | 1          | KUPPLUNGSRAHMEN | FRAME         | CADRE D'ATTELAGE   | BASTIDOR ACOPLAN. | B337 VOLLSTÄNDIG<br>B173 KATEGORIE I |     |
| 3        | 237 6837  | 1          | SEIL            | CABLE/ROPE    | CORDE/CABLE        | CABLE             |                                      |     |
| 6        | 237 8577  | 1          | OBENER-LENKER   | TOP LINK      | BRAS SUPERIEUR     | GUIA SUPERIOR     | B173-KATEGORIE I/I                   |     |
| 9        | 238 5142  | 1          | FEDERBUEGEL     | SPRING CLAMP  | ETRIER DE RESSORT  | ESTRIBO RESORTE   |                                      |     |
| 11       | 121 4375  | 1          | KARABINERHAKEN  | BAYONET LOCK  | CROCHET MOUSQUETON | GANCHO MOSQUETON  | 3 538 A 1                            |     |
| 31       | 237 2606  | 1          | KUPPLUNGSRAHMEN | FRAME         | CADRE D'ATTELAGE   | BASTIDOR ACOPLAN. |                                      |     |
| 32       | 237 2571  | 2          | STECKBOLZEN     | COTTER PIN    | CHEVILLE           | BULON ENCHUFE     |                                      |     |
| 33       | 237 2589  | 1          | STECKBOLZEN     | COTTER PIN    | CHEVILLE           | BULON ENCHUFE     |                                      |     |
| 34       | 237 2542  | 1          | HEBEL           | LEVER/ARM     | LEVIER             | PALANCA           |                                      |     |
| 35       | 237 2587  | 4          | SPLINT          | SPLIT PIN     | GOUPILLE FENDUE    | PASADOR ALETAS    |                                      | 01  |
| 36       | 237 2588  | 1          | FEDER           | SPRING        | RESSORT            | RESORTE/BALLESTA  |                                      | 01  |
| 37       | 237 3226  | 8          | SPANNBUCHSE     | CLAMPING BUSH | DOUILLE DE SERRAGE | CASQUILLO FIADOR  |                                      |     |
| 38       | 110 4876  | 4          | SPANNBUCHSE     | CLAMPING BUSH | DOUILLE DE SERRAGE | CASQUILLO FIADOR  | EG 22/ 28X 16DIN 1498                |     |
| 39       | 111 5473  | 2          | SPANNHUELSE     | DOWEL SLEEVE  | DOUILLE SERRAGE    | CASQUILLO FIADOR  | 8 X 40DIN 1481                       |     |
| 40       | 111 5455  | 1          | SPANNHUELSE     | DOWEL SLEEVE  | DOUILLE SERRAGE    | CASQUILLO FIADOR  | 6 X 32DIN 1481                       |     |
| 41       | 116 8224  | 1          | SCHMIERNIPPEL   | LUBE FITTING  | RACCORD GRAISSEUR  | NIPLE LUBRICACION | SA 6H 3360                           |     |

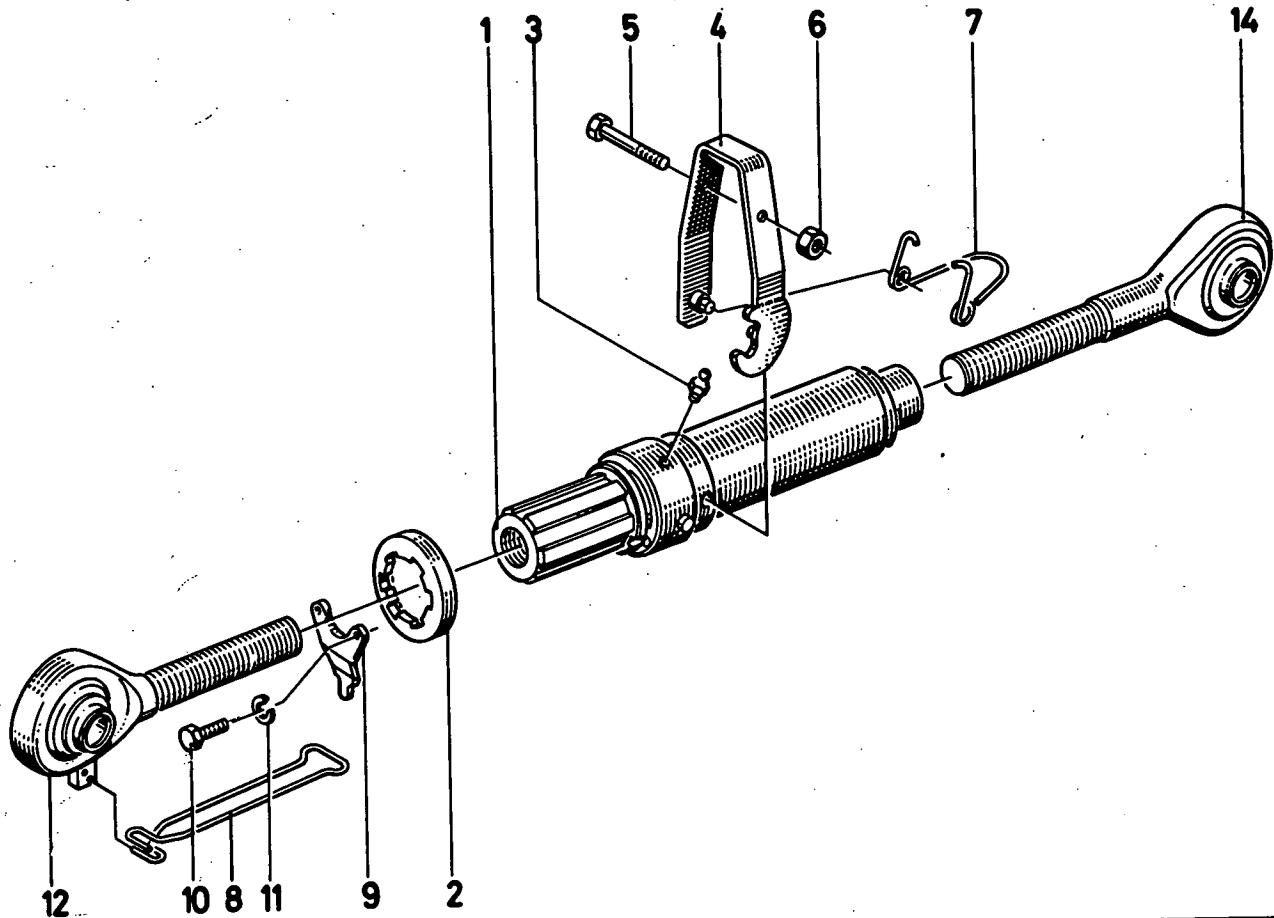

1904-17 501 5844

| Bild-Nr. | Teile-Nr. | Stück-Zahl | Deutsch            | English           | Français          | Español            | Nummer/Bemerkung           | ETK |
|----------|-----------|------------|--------------------|-------------------|-------------------|--------------------|----------------------------|-----|
| 1        | 237 8617  | 1          | SPANNSCHLOSS       | TURNBUCKLE        | TENDEUR           | CIERRE TENSOR      |                            |     |
| 2        | 237 8618  | 1          | SCHUTZKAPPE        | CAP               | CAPUCHON PROTECT  | SOMBRERETE PROTEC. |                            | 03  |
| 3        | 116 8224  | 1          | KEGELSCHMIERNIPPEL | LUBE FITTING      | GRAISSEUR CONIQUE | ENGRASADOR CONICO  | SA 6H 3360                 |     |
| 4        | 237 8273  | 1          | HEBEL              | LEVER/ARM         | LEVIER            | PALANCA            |                            |     |
| 5        | 110 4310  | 1          | SECHSKANTSCHRAUBE  | HEX-BOLT          | VIS 6 PANS        | TORNILLO HEXAGONAL | M 6 X 30 DIN 933-M10-9-A4C |     |
| 6        | 111 4357  | 1          | SECHSKANTMUTTER    | HEX-NUT           | ECROU 6 PANS      | TUERCA HEXAGONAL   | M 6 DIN 985-A VZKC         |     |
| 7        | 237 8235  | 1          | FEDER              | SPRING            | RESSORT           | RESORTE/BALLESTA   |                            | 03  |
| 8        | 237 3584  | 1          | SICHERUNGSFEDER    | LOCKING SPRING    | RESSORT D ARRET   | RESORTE SEGURIDAD  |                            |     |
| 9        | 237 8619  | 1          | SICHERUNGSLASCHE   | SAFETY-PLATE      | ECLISSE D ARRET   | ECLISA SEGURO      |                            |     |
| 10       | 110 3999  | 2          | SECHSKANTSCHRAUBE  | HEX-BOLT          | VIS 6 PANS        | TORNILLO HEXAGONAL | M 5X16 DIN 933-8.8 A4C     |     |
| 11       | 110 2796  | 2          | FEDERRING          | SPRING LOCKWASHER | RONDELLE GROVER   | ARANDELA ELASTICA  | A 5 DIN 128 A4C            |     |
| 12       | 237 8621  | 1          | DRUCKSTANGE        | THRUST ROD        | BRAS DE LEVIER    | VARILLA PRESION    | 8195-LINKS                 |     |
| 14       | 237 8620  | 1          | DRUCKSTANGE        | THRUST ROD        | BRAS DE LEVIER    | VARILLA PRESION    | 8267-RECHTS                |     |



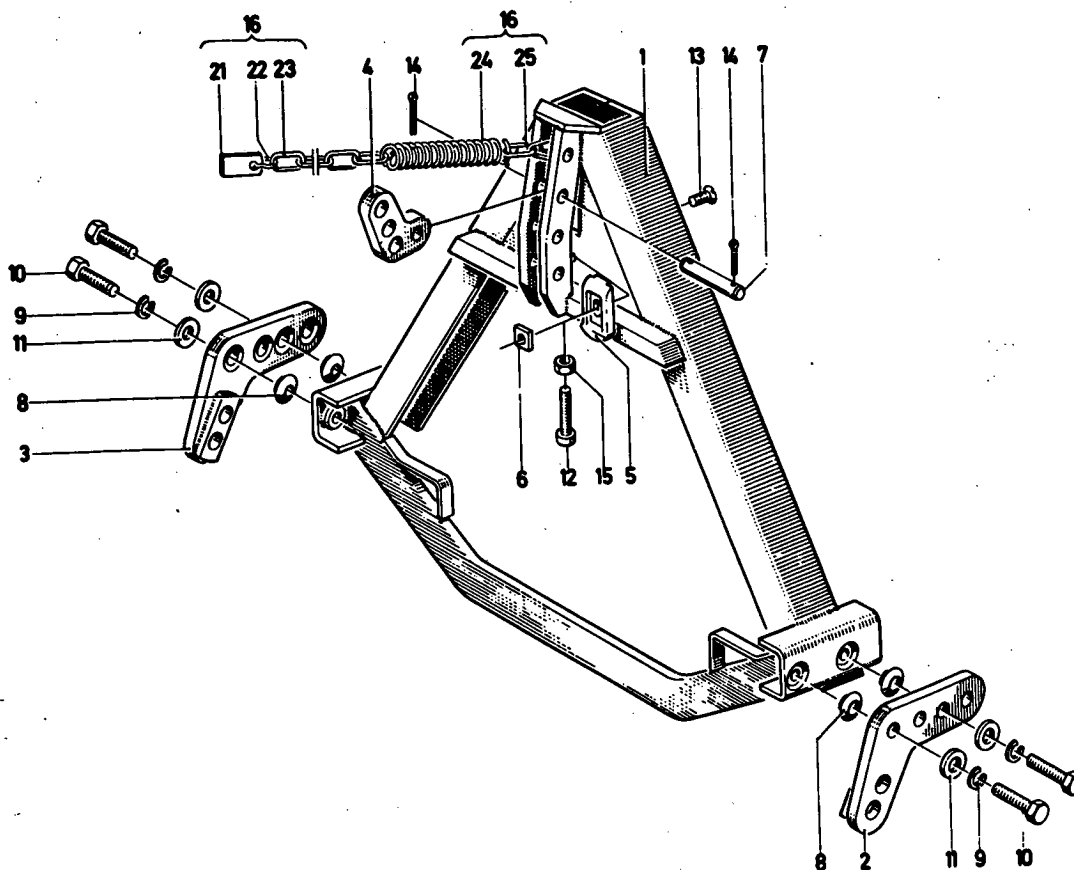

1971-17 501 5843

| Bild Nr. | Teil-Nr. | Stück-Zahl | Deutsch           | English           | Français           | Español            | Nummer/Bemerkung            | ETK |
|----------|----------|------------|-------------------|-------------------|--------------------|--------------------|-----------------------------|-----|
| 1        | 237 8096 | 1          | RAHMEN            | FRAME             | CHASSIS/CADRE      | BASTIDOR/MARCO     |                             |     |
| 2        | 237 7749 | 1          | ANSCHLUSSSTUECK   | CONNECTOR         | PIECE DE RACCORDEN | PZA-LIGACION       | B326-UNTEN-RECHTS           |     |
| 3        | 237 7738 | 1          | ANSCHLUSSSTUECK   | CONNECTOR         | PIECE DE RACCORDEN | PZA-LIGACION       | B325-UNTEN-LINKS            |     |
| 4        | 237 7758 | 1          | ANSCHLUSSSTUECK   | CONNECTOR         | PIECE DE RACCORDEN | PZA-LIGACION       | B292 08EN                   |     |
| 5        | 237 7756 | 1          | PLATTE            | PLATE             | PLAQUE             | PLACA              |                             |     |
| 6        | 237 7512 | 1          | VIERKANTHUTTER    | SQUARE NUT        | ECROU QUATRE PANS  | TUERCA CUADRADA    |                             |     |
| 7        | 237 9675 | 1          | BOLZEN            | PIN/BOLT/STUD     | BOULON/AXE         | BULON              |                             |     |
| 8        | 237 7513 | 4          | KONUSBUCHSE       | TAPERED BUSH      | BAGUE CONIQUE      | CASQUILLO CONICO   |                             |     |
| 9        | 110 2803 | 4          | FEDERRING         | SPRING LOCKWASHER | RONDELLE GROMER    | ARANDELA ELASTICA  | A 16 DIN 128-A4C            |     |
| 10       | 111 1861 | 4          | SECHSKANTSCHRAUBE | HEX-BOLT          | VIS 6 PANS         | TORNILLO HEXAGONAL | M16X 55 DIN 933-M 8-8 A4C   |     |
| 11       | 110 7317 | 4          | SCHEIBE           | DISC/PANE/PLATE   | RONDELLE/DISQUE    | DISCO              | A17 DIN 125-ST-A4C          |     |
| 12       | 110 8674 | 1          | ZYLINDERSCHRAUBE  | CHEESE-HEAD SCREW | VIS TETE CYLINDR.  | TORN-CBZA-CILIND.  | M12 X 60DIN 7984-A4C        |     |
| 13       | 110 4567 | 1          | SENKSCHRAUBE      | C SUNK SCREW      | VIS TETE NOYEE     | TORN-CABZA-EMBTID  | M12 X 35DIN 7991-A4C        |     |
| 14       | 110 6468 | 2          | SPLINT            | SPLIT PIN         | GOUVILLE PENDUE    | PASADOR-ALETAS     | 5 X 30DIN 94-A4C            |     |
| 15       | 110 8066 | 1          | SECHSKANTHUTTER   | HEX-NUT           | ECROU 6 PANS       | TUERCA HEXAGONAL   | M12 DIN 555                 |     |
| 16       | 237 8645 | 1          | AUSGLEICHFEDER    | BALANCING SPRING  | RESSORT COMPENSAT  | RESORTE COMPENS.   | B228-VUR FUER AUFSATTELPLUG |     |
| 21       | 237 8635 | 1          | LASCHE            | CONNECTING PLATE  | ECLISSE            | ECLISA             |                             |     |
| 22       | 113 2705 | 1          | SCHAEKEL          | SHACKLE           | MANILLE            | ESLABON GIRATORIO  | A 0-16DIN82101-A4C          |     |
| 23       | 113 2704 | 1          | KETTE             | CHAIN/TRACK       | CHAINE/CHENILLE    | CADENA             | 0-6847 5 DIN 763            |     |
| 24       | 237 8647 | 1          | ZUGFEDER          | DRAW SPRING       | RESSORT TRACTION   | RESORTE TRACCION   |                             |     |
| 25       | 237 8634 | 1          | ANHAENGEOSE       | HITCH LUG         | OEILLET ATTELAGE   | ARGOLLA ENGANCHE   |                             |     |

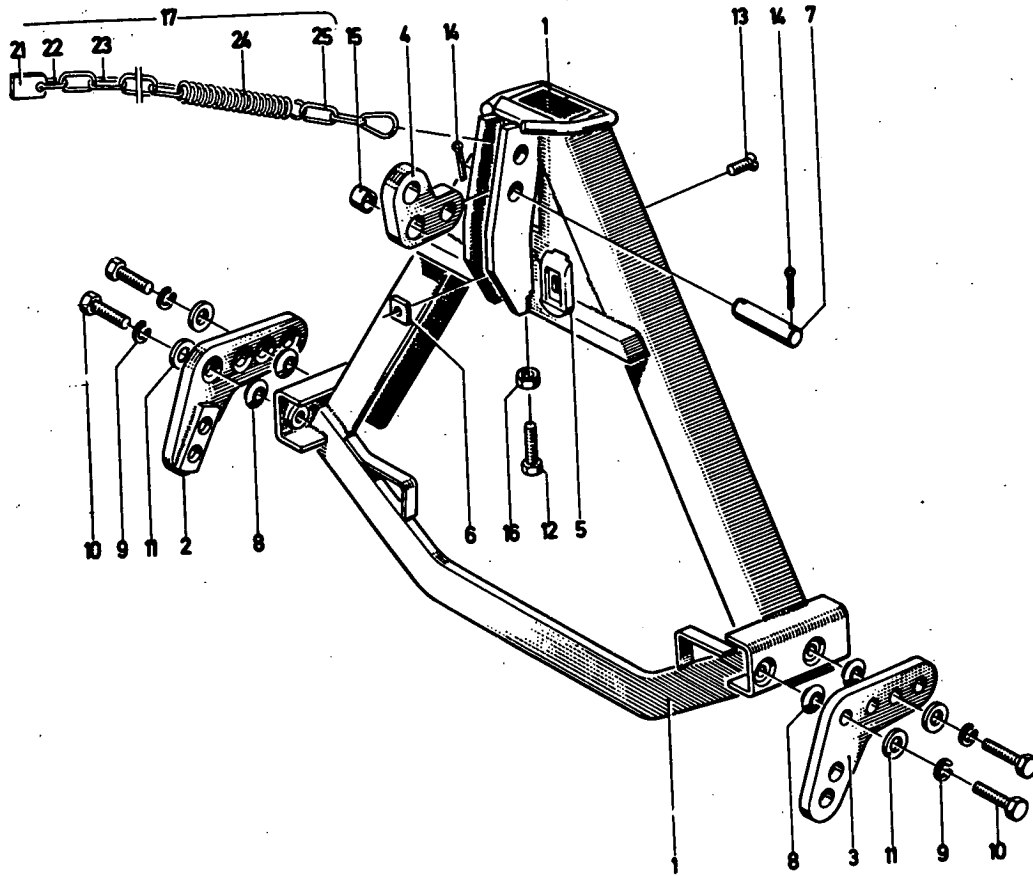

1971-17 501 5842

| Bild Nr. | Teile-Nr. | Stück-Zahl | Deutsch           | English           | Français           | Español            | Nummer/Bemerkung            | ETK |
|----------|-----------|------------|-------------------|-------------------|--------------------|--------------------|-----------------------------|-----|
| 1        | 237 8098  | 1          | RAHMEN            | FRAME             | CHASSIS/CADRE      | BASTIDOR/MARCO     | 8292 SCHWER                 |     |
| 2        | 237 7753  | 1          | ANSCHLUSSSTUECK   | CONNECTOR         | PIECE DE RACCORDEM | PZA-LIGACION       | 8325 UNTEN LINKS            |     |
| 3        | 237 7751  | 1          | ANSCHLUSSSTUECK   | CONNECTOR         | PIECE DE RACCORDEM | PZA-LIGACION       | 8326 UNTEN RECHTS           |     |
| 4        | 237 7757  | 1          | ANSCHLUSSSTUECK   | CONNECTOR         | PIECE DE RACCORDEM | PZA-LIGACION       | 8292 OBEN                   |     |
| 5        | 237 7756  | 1          | PLATTE            | PLATE             | PLAQUE             | PLACA              |                             |     |
| 6        | 237 7512  | 1          | VIERKANTMUTTER    | SQUARE NUT        | ECROU QUATRE PANS  | TUERCA CUADRADA    |                             |     |
| 7        | 237 7514  | 1          | BOLZEN            | PIN/BOLT/STUD     | BOULON/AXE         | BULON              |                             |     |
| 8        | 237 7511  | 4          | KONUSBUCHE        | TAPERED BUSH      | BAGUE CONIQUE      | CASQUILLO CONICO   |                             |     |
| 9        | 110 2805  | 4          | FEDERRING         | SPRING LOCKWASHER | RONDELLE GROMER    | ARANDELA ELASTICA  | A 20 DIN 128-A4C            |     |
| 10       | 111 2057  | 4          | SECHSKANTSCHRAUBE | HEX-BOLT          | VIS 6 PANS         | TORNILLO HEXAGONAL | M20X 70 S DIN 933-M10-9     |     |
| 11       | 110 7124  | 4          | SCHIEBE           | DISC/PANE/PLATE   | RONDELLE/DISQUE    | DISCO              | A21 DIN 125-ST-A4C          |     |
| 12       | 111 2572  | 1          | SECHSKANTSCHRAUBE | HEX-BOLT          | VIS 6 PANS         | TORNILLO HEXAGONAL | M12X 60 DIN 933-M 8-8-A4C   |     |
| 13       | 110 4567  | 1          | SENKSCHRAUBE      | C SUNK SCREW      | VIS TETE NOYEE     | TORN-CABZA-EMBUTID | M12 X 35DIN 7993-A4C        |     |
| 14       | 110 6484  | 2          | SPLINT            | SPLIT PIN         | GOUPILLE FENDUE    | PASADOR ALETAS     | 6 X 40DIN 94-A4C            |     |
| 15       | 111 2679  | 1          | SPANNBUCHE        | CLAMPING BUSH     | DOUILLE DE SERRAGE | CASQUILLO FIADOR   | E6 25/ 32X 45DIN 1498       |     |
| 16       | 110 8066  | 1          | SECHSKANTMUTTER   | HEX.NUT           | ECROU 6 PANS       | TUERCA HEXAGONAL   | M12 DIN 555                 |     |
| 17       | 237 8645  | 1          | AUSGLEICHFEDER    | BALANCING SPRING  | RESSORT COMPENSAT  | RESORTE COMPENS-   | 8228 NUR FUER AUFSATTELFLUG |     |
| 21       | 237 8635  | 1          | LASCHE            | CONNECTING PLATE  | ECLISSE            | ECLISA             |                             |     |
| 22       | 111 2705  | 1          | SCHAEKEL          | SHACKLE           | HAMILLE            | ESLABON GIRATORIO  | A 0-16DIN82101-A4C          |     |
| 23       | 111 2704  | 1          | KETTE             | CHAIN/TRACK       | CHAÎNE/CHENILLE    | CADENA             | 0-6844 S DIN 763            |     |
| 24       | 237 8647  | 1          | ZUGFEDER          | DRAW SPRING       | RESSORT TRACTION   | RESORTE TRACCION   |                             |     |
| 25       | 237 8634  | 1          | ANHAENGESE        | HITCH LUG         | OEUillet ATTELAGE  | ARGOLLA ENGANCHE   |                             |     |

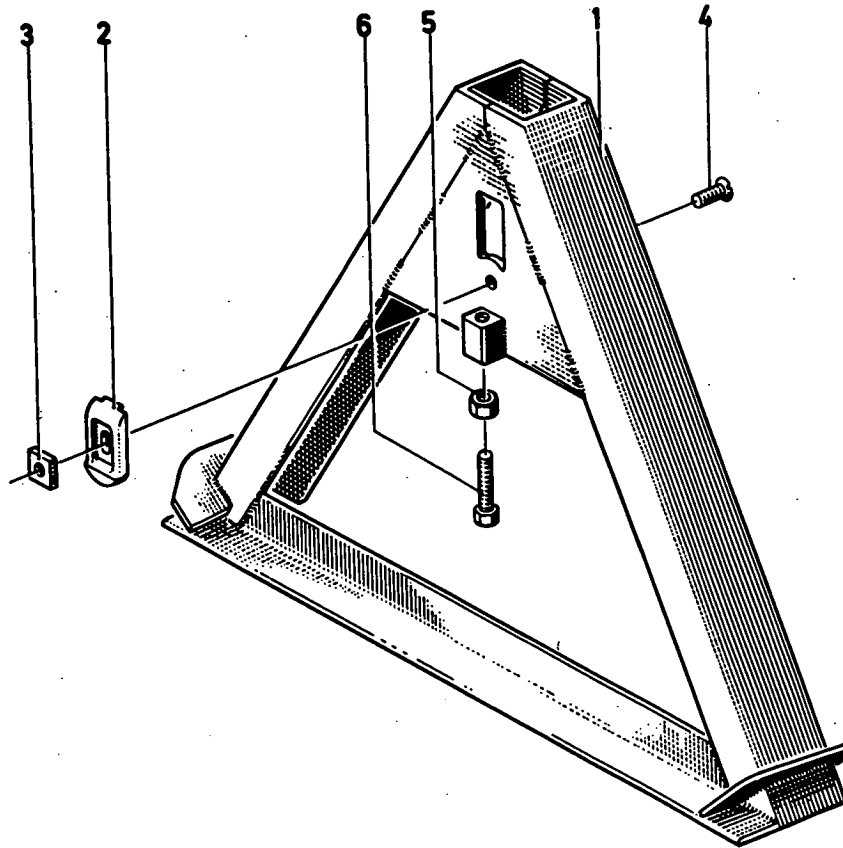

1971-17 501 5846

| Bild Nr. | Teil-Nr. | Stück-Zahl | Deutsch           | English       | Français          | Español            | Nummer/Bemerkung          | ETK |
|----------|----------|------------|-------------------|---------------|-------------------|--------------------|---------------------------|-----|
| 1        | 237 8595 | 1          | RAHMEN            | FRAME         | CHASSIS/CADRE     | BASTIDOR/MARCO     |                           |     |
| 2        | 237 7756 | 1          | PLATTE            | PLATE         | PLAQUE            | PLACA              |                           |     |
| 3        | 237 7532 | 1          | VIERKANTMUTTER    | SQUARE NUT    | ECROU-QUATRE PANS | TUERCA CUADRADA    |                           |     |
| 4        | 110 4567 | 1          | SENKSCRAUBE       | C SLINK SCREW | VIS TETE NOYEE    | TORN-CABZA-EMBUTID | M12 X 35DIN 7991-ANC      |     |
| 5        | 110 8066 | 1          | SECHSKANTMUTTER   | HEX-NUT       | ECROU 6 PANS      | TUERCA HEXAGONAL   | M12 DIN 555               |     |
| 6        | 111 2572 | 1          | SECHSKANTSCHRAUBE | HEX-BOLT      | VIS 6 PANS        | TORNILLO HEXAGONAL | M12X 60 DIN 933-N 8-8-ANC |     |

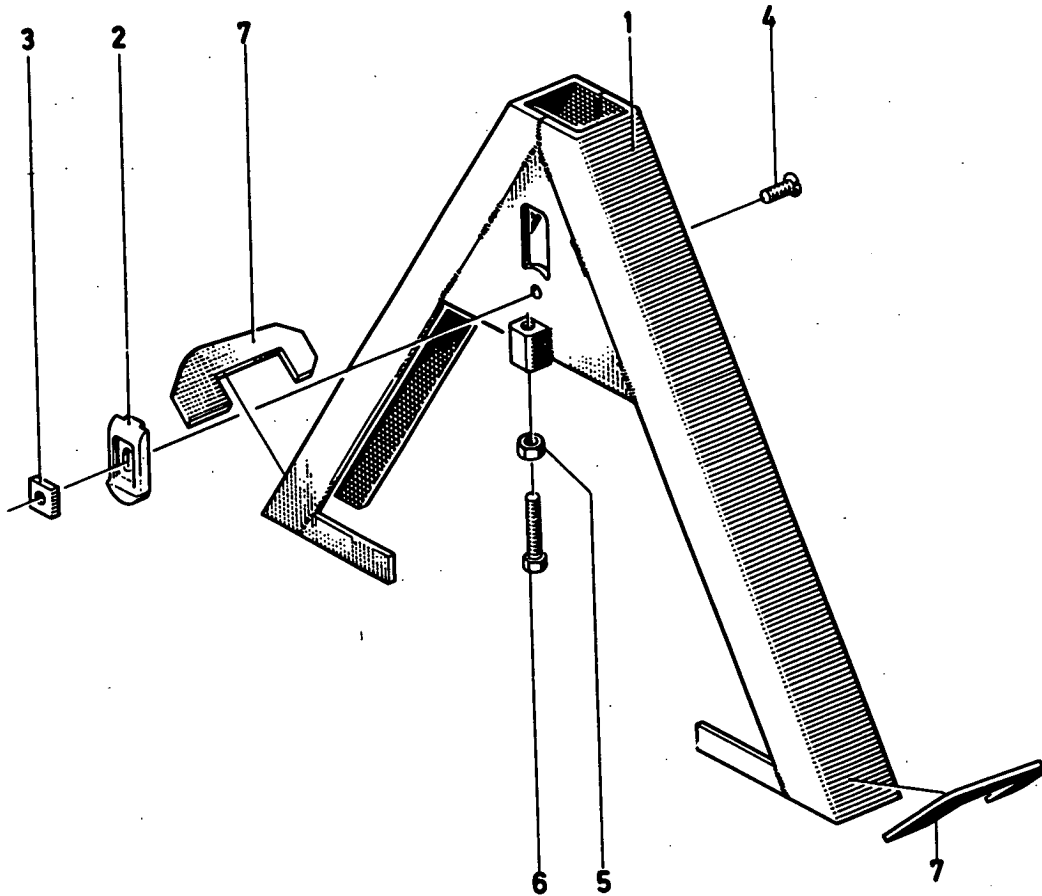

1971-17 501 5847

| Bild Nr. | Teil-Nr. | Stück-Zahl | Deutsch           | English      | Français           | Español            | Nummer/Bemerkung          | ETK |
|----------|----------|------------|-------------------|--------------|--------------------|--------------------|---------------------------|-----|
| 1        | 237 8583 | 1          | RAHMEN            | FRAME        | CHASSIS/CADRE      | BASTIDOR/MARCO     |                           |     |
| 2        | 237 7756 | 1          | PLATTE            | PLATE        | PLAQUE             | PLACA              |                           |     |
| 3        | 237 7512 | 1          | VIERKANTMUTTER    | SQUARE-NUT   | ECROU QUATRE PANS  | TUERCA CUADRADA    |                           |     |
| 4        | 110 4567 | 1          | SENKSCHRAUBE      | C SUNK SCREW | VIS TETE NOYEE     | TORN.CABZA-ENBUTID | M12 X 35DIN 7993-A4C      |     |
| 5        | 110 8066 | 1          | SECHSKANTMUTTER   | HEX-NUT      | ECROU 6 PANS       | TUERCA HEXAGONAL   | M12 DIN 555               |     |
| 6        | 111 2572 | 1          | SECHSKANTSCHRAUBE | HEX-BOLT     | VIS 6 PANS         | TORNILLO HEXAGONAL | M12X 60 DIN 933-M 8-8-A4C |     |
| 7        | 237 8592 | 1          | VERSTAERKUNG      | STIFFENER    | RENFORCEN-RAIDISS- | REFUERZO           |                           |     |

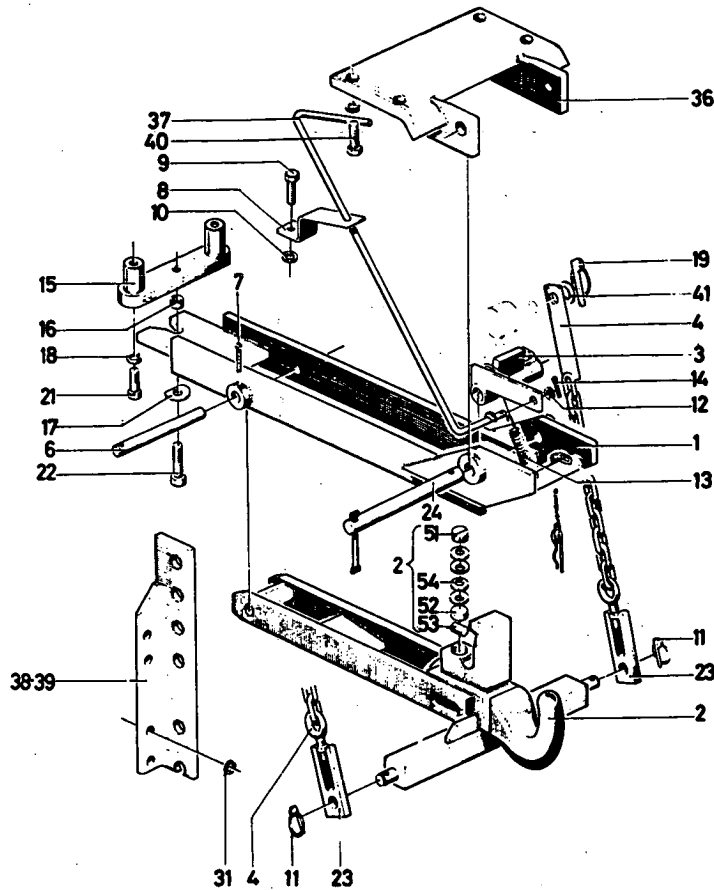

1926-20 500 5131

| Bild Nr. | Teile-Nr. | Stück-Zahl | Deutsch           | English           | Français         | Español            | Nummer/Bemerkung                 | ETK |
|----------|-----------|------------|-------------------|-------------------|------------------|--------------------|----------------------------------|-----|
| 1        | 231 2770  | 1          | FÜHRUNGSRAHMEN    | GUIDE FRAME       | CADRE DE GUIDAGE | BASTIDOR GUIA      |                                  |     |
| 2        | 231 2781  | 1          | ZUGHAKEN          | TOWHOOK           | CROCHET TRACTION | GANCHO TRACCION    | 8347, VOLLSTÄNDIG MIT POS. 51-54 |     |
| 3        | 231 2799  | 1          | KLINKE            | RATCHET/PAWL      | LOQUET/POIGNEE   | TRINQUETE/MANILLA  |                                  |     |
| 4        | 231 2767  | 2          | KEITTE            | CHAIN/TRACK       | CHAINE/CHENILLE  | CABENA             |                                  |     |
| 6        | 231 2779  | 1          | BOLZEN            | PIN/BOLT/STUD     | BOULON/AXE       | BULON              |                                  |     |
| 7        | 110 6511  | 1          | SPLINT            | SPLIT PIN         | GOUPILLE FENDUE  | PASADOR ALETAS     | 10 X 55DIN 94                    |     |
| 8        | 232 4393  | 1          | LASCHE            | CONNECTING PLATE  | ECLISSE          | ECLISA             |                                  |     |
| 9        | 112 4811  | 1          | SECHSKANTSCHRAUBE | HEX-BOLT          | VIS 6 PANS       | TORNILLO HEXAGONAL | M14X 120 DIN 933-M 8-8 A4C       |     |
| 10       | 110 7114  | 2          | SCHLEIBE          | DISC/PANE/PLATE   | RONDELLE/DISQUE  | DISCO              | A15 DIN 125-ST-A4C               |     |
| 11       | 110 1084  | 2          | KLAPPSTECKER      | FOLDING PLUG      | FICHE PLIANTE    | CLAVIJA ARTICULADA | 8 D1411023-ST50-2 VZKC           |     |
| 12       | 110 7110  | 1          | SCHLEIBE          | DISC/PANE/PLATE   | RONDELLE/DISQUE  | DISCO              | A13 DIN 125-ST-A4C               |     |
| 13       | 338 9261  | 2          | ZUGFEDER          | DRAW SPRING       | RESSORT TRACTION | RESORTE TRACCION   | 1145-02-01-06                    |     |
| 14       | 110 6447  | 1          | SPLINT            | SPLIT PIN         | GOUPILLE FENDUE  | PASADOR ALETAS     | 4 X 20DIN 94-A4C                 |     |
| 15       | 232 4372  | 1          | BOCK              | SUPPORT           | CHEVALET         | CABALLETE          |                                  |     |
| 16       | 231 2766  | 1          | BUECHSE           | BUSH              | BOÎTE            | CASQUILLO          |                                  |     |
| 17       | 340 0865  | 1          | SCHLEIBE          | DISC/PANE/PLATE   | RONDELLE/DISQUE  | DISCO              | 1941-14-05-13                    |     |
| 18       | 110 2802  | 2          | FEDERRING         | SPRING LOCKWASHER | RONDELLE GROWER  | ARANDELA ELASTICA  | A 14 DIN 128 A4C                 |     |
| 19       | 338 7615  | 2          | KLAPPSTECKER      | FOLDING PLUG      | FICHE PLIANTE    | CLAVIJA ARTICULADA | 1124-63-01-13                    |     |
| 21       | 111 1759  | 2          | SECHSKANTSCHRAUBE | HEX-BOLT          | VIS 6 PANS       | TORNILLO HEXAGONAL | M14X 95 DIN 931-M10-9 A4C        |     |
| 22       | 111 2677  | 1          | SECHSKANTSCHRAUBE | HEX-BOLT          | VIS 6 PANS       | TORNILLO HEXAGONAL | M16X 50 DIN 933-M 8-8 A4C        |     |
| 23       | 231 2828  | 2          | LASCHE            | CONNECTING PLATE  | ECLISSE          | ECLISA             |                                  |     |
| 24       | 338 7618  | 1          | STECKBOLZEN       | COTTER PIN        | CHEVILLE         | BULON ENCHUFE      | 1124-63-04-10                    |     |
| 31       | 110 2803  | 5          | FEDERRING         | SPRING LOCKWASHER | RONDELLE GROWER  | ARANDELA ELASTICA  | A 16 DIN 128 A4C                 |     |
| 36       | 231 3372  | 1          | TRAGRAHMEN        | SUPPORT FRAME     | CADRE PORTEUR    | BASTIDOR PORTANTE  |                                  |     |
| 37       | 231 3377  | 1          | AUSKLINKSTANGE    | KICK-OUT ROD      | TIGE A DECLIC    | VARILLA DISPARO    |                                  |     |

| Bild Nr. | Teil-Nr. | Stück-Zahl | Deutsch           | English         | Français           | Español            | Nummer/Bemerkung          | ETK |
|----------|----------|------------|-------------------|-----------------|--------------------|--------------------|---------------------------|-----|
| 38       | 232 4386 | 1          | FUEHRUNGSLEISTE   | GUIDE RAIL      | BARRE CONDUCTR     | LISTON GUIA        | B195-LINKS                |     |
| 39       | 231 3385 | 1          | FUEHRUNGSLEISTE   | GUIDE RAIL      | BARRE CONDUCTR     | LISTON GUIA        | B267-RECHTS               |     |
| 40       | 111 2679 | 4          | SECHSKANTSCHRAUBE | HEX-BOLT        | VIS 6 PANS         | TORNILLO HEXAGONAL | M16x 35 DIN 933-M 8-8 A4C |     |
| 41       | 111 5021 | 2          | SCHEIBE           | DISC/PANE/PLATE | RONDELLE/DISQUE    | DISCO              | 23DIN 1440 VZKC           |     |
| 51       | 231 2792 | 1          | DECKEL            | COVER           | COUVERCLE          | TAPA               |                           |     |
| 52       | 338 7577 | 1          | BOLZEN            | PIN/BOLT/STUD   | BOULON/AXE         | BULON              | 1110-63-03-11             |     |
| 53       | 338 7574 | 1          | ZYLINDERROLLE     | PARALLEL ROLLER | ROULEAU CYLINDR.   | RODILLO CILINDR.   | 1110-63-03-07             |     |
| 54       | 111 6029 | 13         | TELLERFEDER       | CUP SPRING      | RESSORT BELLEVILLE | RESORTE DE PLATO   | A 25 DIN 2093             |     |

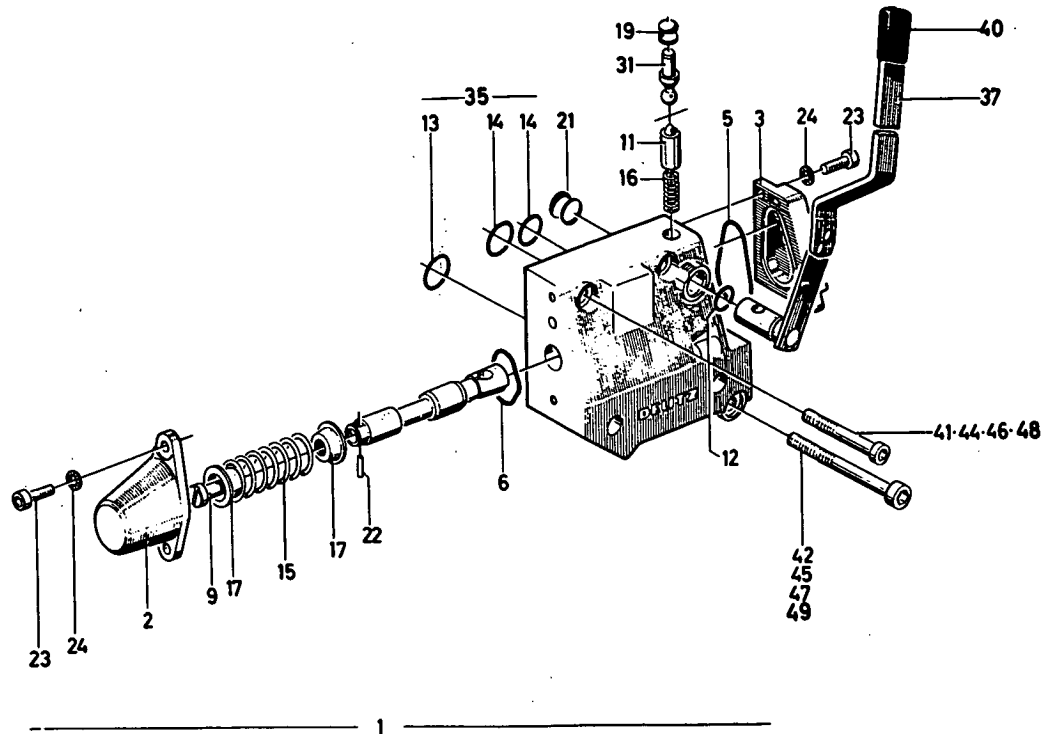

1804-40 500 5134

| Bld. Nr. | Teil-Nr. | Stück-Zahl | Deutsch            | English            | Français           | Español            | Nummer/Bemerkung                           | ETK |
|----------|----------|------------|--------------------|--------------------|--------------------|--------------------|--|-----|
| 1        | 233 3728 | 1          | ENDSTEUERGERÄT     | TERMINAL UNIT      | DISTRIBUTEUR TERM. | APTO.MANDO FINAL   |  |     |
| 2        | 340 1334 | 1          | BECKEL             | COVER              | COUVERCLE          | TAPA               | 1952-08-61-02                              |     |
| 3        | 340 1335 | 1          | BECKEL             | COVER              | COUVERCLE          | TAPA               | 1952-08-61-03                              |     |
| 5        | 340 1337 | 1          | DICHTUNG           | GASKET             | GARNITURE/JOINT    | JUNTA              | 1952-08-61-05                              | 01  |
| 6        | 340 1338 | 1          | DICHTUNG           | GASKET             | GARNITURE/JOINT    | JUNTA              | 1952-08-61-06                              | 01  |
| 9        | 340 1340 | 1          | BOLZEN             | PIN/BOLT/STUD      | BOULON/AXE         | BULON              | 1952-08-61-09                              |     |
| 11       | 340 1342 | 1          | RASTE              | DETENT/NOTCH       | CRAN               | TRINQUETE          | 1952-08-61-11                              |     |
| 12       | 116 9761 | 1          | O-RING             | O-SEAL             | BAGUE TORIQUE      | ANILLO O           | 10 X2 H 2927-6I DEUTZ 9                    | 01  |
| 13       | 116 9764 | 1          | O-RING             | O-SEAL             | BAGUE TORIQUE      | ANILLO O           | 22 X2 H 2927-6I DEUTZ 9                    | 01  |
| 14       | 116 9763 | 2          | O-RING             | O-SEAL             | BAGUE TORIQUE      | ANILLO O           | 18 X2 H 2927-6I DEUTZ 9                    | 01  |
| 15       | 340 1343 | 1          | DRUCKFEDER         | COMPRESSION SPRING | RESSORT DE COMPR   | RESORTE PRESION    | 1952-08-61-15                              |     |
| 16       | 340 1344 | 1          | DRUCKFEDER         | COMPRESSION SPRING | RESSORT DE COMPR   | RESORTE PRESION    | 1952-08-61-16                              |     |
| 17       | 340 1345 | 2          | FEDERTEILEN        | SPRING CAP         | CUVETTE DE RESSORT | PLATO RESORTE      | 1952-08-61-17                              |     |
| 19       | 110 2507 | 2          | VERSCHLUSSSCHEIBE  | DISHED PLUG        | RONDELLE OBTURAT.  | ARANDELA CIERRE    | 10DIN 470 VZKC                             |     |
| 21       | 110 2347 | 2          | VERSCHLUSSSCHEIBE  | DISHED PLUG        | RONDELLE OBTURAT.  | ARANDELA CIERRE    | 14DIN 470 VZKC                             |     |
| 22       | 111 5405 | 1          | SPANNHUELSE        | DOVEL SLEEVE       | DOUILLE SERRAGE    | CASQUILLO FIADOR   | 3 X 12DIN 1481                             |     |
| 23       | 110 0925 | 4          | ZYLINDERSCHRAUBE   | CHEESE-HEAD SCREW  | VIS TETE CYLINDR.  | TORN-CBZA-CILIND.  | M 5X 15DIN 912- 6-9 VZKC                   |     |
| 24       | 116 7193 | 4          | SICHERUNGSSCHNEIBE | LOCKING WASHER     | RONDELLE SECURITE  | ARANDELA SEGURIDAD | 5 H 2203                                   |     |
| 31       | 231 1420 | 1          | KUGELBOLZEN        | BALL-END PIN       | BOULON A ROTULE    | BULON ESFERICO     |  |     |
| 35       | 231 8930 | 1          | REPARATURSATZ      | REPAIR KIT         | LOT DE REPARATION  | LOTE REPARACIONES  | 8347-VOLLSTAENDIG MIT POS-<br>5.6.12-14.22 |     |
| 37       | 233 3723 | 1          | SCHALTWELLE        | SHIFTING SHAFT     | ARBRE COMMANDE     | EJE MANDO/CAMBIO   |  |     |
| 40       | 339 1955 | 1          | HANDGRIFF          | HANDLE             | POIGNEE            | PUNO               | 1424-14-01.09                              |     |
| 41       | 112 3701 | 2          | ZYLINDERSCHRAUBE   | CHEESE-HEAD SCREW  | VIS TETE CYLINDR.  | TORN-CBZA-CILIND.  | M 8X 40DIN 912- 8-8 A4C                    |     |
| 42       | 110 1405 | 1          | ZYLINDERSCHRAUBE   | CHEESE-HEAD SCREW  | VIS TETE CYLINDR.  | TORN-CBZA-CILIND.  | M 8X 50DIN 912- 8-8 A4C                    |     |
| 44       | 111 0622 | 2          | ZYLINDERSCHRAUBE   | CHEESE-HEAD SCREW  | VIS TETE CYLINDR.  | TORN-CBZA-CILIND.  | M 8X 80DIN 912- 8-8-A4C                    |     |

| Bld<br>Nr. | Teil-Nr. | Stück-<br>Zahl | Deutsch          | English           | Français          | Espanol           | Nummer/Bemerkung         | ETK |
|------------|----------|----------------|------------------|-------------------|-------------------|-------------------|--------------------------|-----|
| 45         | 110 1406 | 1              | ZYLINDERSCHRAUBE | CHEESE-HEAD SCREW | VIS TETE CYLINDR. | TORN-CBZA-CILIND. | M 8X 90DIN 912- 8-8 A4C  |     |
| 46         | 112 3702 | 2              | ZYLINDERSCHRAUBE | CHEESE-HEAD SCREW | VIS TETE CYLINDR. | TORN-CBZA-CILIND. | M 8X 120DIN 912- 8-8 A4C |     |
| 47         | 110 1407 | 1              | ZYLINDERSCHRAUBE | CHEESE-HEAD SCREW | VIS TETE CYLINDR. | TORN-CBZA-CILIND. | M 8X 130DIN 912- 8-8 A4C |     |
| 48         | 110 2048 | 2              | ZYLINDERSCHRAUBE | CHEESE-HEAD SCREW | VIS TETE CYLINDR. | TORN-CBZA-CILIND. | M 8X 160DIN 912- 8-8-A4C |     |
| 49         | 112 3703 | 1              | ZYLINDERSCHRAUBE | CHEESE-HEAD SCREW | VIS TETE CYLINDR. | TORN-CBZA-CILIND. | M 8X 170DIN 912-10-9-A4C |     |





DEUTZ-ZWISCHENSTEUERGERÄT, EINFACH WIRKEND  
 INTERMEDIATE CONTROL UNIT, DEUTZ, SINGLE-ACTING  
 DISTRIBUTEUR INTERMÉDIAIRE DEUTZ A SIMPLE EFFET  
 APARATO DE MANDO INTERMEDIO, TIPO DEUTZ, DE SIMPLE EFECTO

1804-40 500 5135

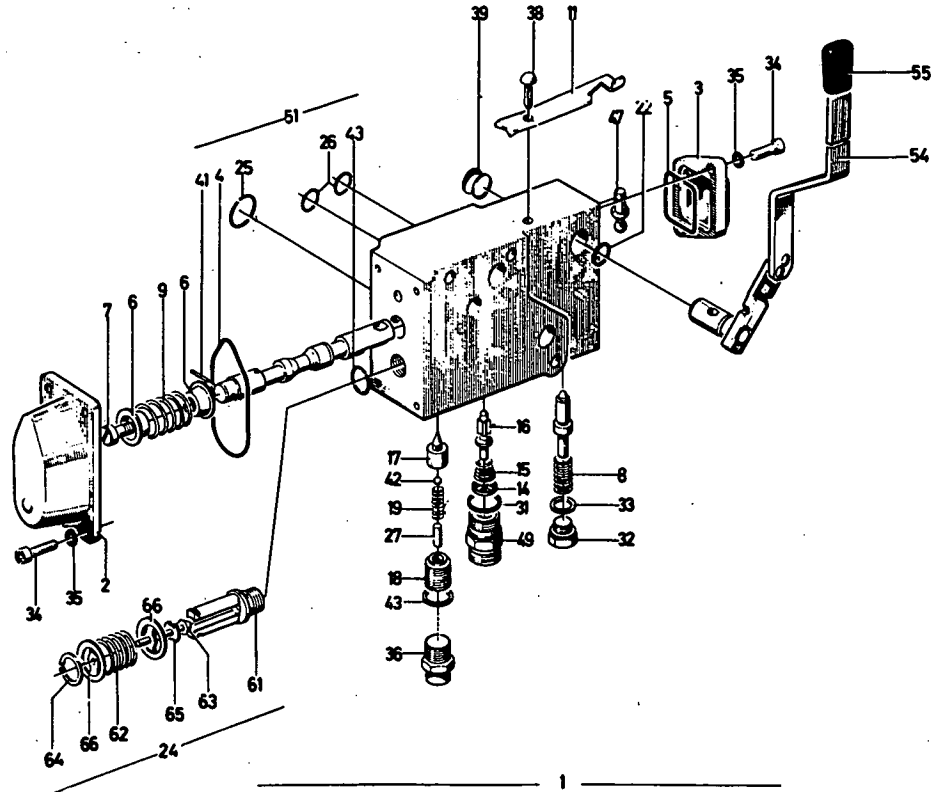

1804-40 500 5135

| Bild Nr. | Teile-Nr. | Stück-Zahl | Deutsch            | English            | Français           | Español            | Nummer/Bemerkung                                       | ETK |
|----------|-----------|------------|--------------------|--------------------|--------------------|--------------------|--|-----|
| 1        | 233 3726  | 1          | ZWISCHENGERÄT      | INTERMEDIATE UNIT  | DISTRIBUTEUR INT.  | APTO-MANDO INTERN. | 8070-EINFACH   |     |
| 2        | 340 1346  | 1          | BECKEL             | COVER              | COUVERCLE          | TAPA               | 1952-38-62-02  |     |
| 3        | 340 1349  | 1          | DECKEL             | COVER              | COUVERCLE          | TAPA               | 1952-38-62-03  |     |
| 4        | 340 1350  | 1          | DICHTUNG           | GASKET             | GARNITURE/JOINT    | JUNTA              | 1952-38-62-04  | 01  |
| 5        | 340 1351  | 1          | DICHTUNG           | GASKET             | GARNITURE/JOINT    | JUNTA              | 1952-38-62-05  | 01  |
| 6        | 340 1345  | 2          | FEDERTELLER        | SPRING CAP         | CUVETTE DE RESSORT | PLATO RESORTE      | 1952-08-62-17  |     |
| 7        | 340 1340  | 1          | BOLZEN             | PIN/BOLT/STUD      | BOULON/AXE         | BULON              | 1952-38-61-09  |     |
| 8        | 340 1344  | 1          | DRUCKFEDER         | COMPRESSION SPRING | RESSORT DE COMPR   | RESORTE PRESION    | 1952-38-61-16  |     |
| 9        | 340 1343  | 1          | DRUCKFEDER         | COMPRESSION SPRING | RESSORT DE COMPR   | RESORTE PRESION    | 1952-38-61-15  |     |
| 11       | 340 1352  | 1          | BLATTFEDER         | LEAF SPRING        | RESSORT A LAMES    | BALLESTA           | 1952-08-62-13  |     |
| 14       | 340 1355  | 1          | STUETZE            | SUPPORT            | SUPPORT/APPUI      | APOYO              | 1952-38-62-14  |     |
| 15       | 340 1356  | 1          | KEGELFEDER         | TAPER SPRING       | RESSORT CONIQUE    | RESORTE CONICO     | 1952-38-62-15  |     |
| 16       | 340 1357  | 1          | VENTILKEGEL        | VALVE CONE         | CONE DE SOUPE      | CONO DE VALVULA    | 1952-38-62-16  |     |
| 17       | 340 1358  | 1          | VENTIL             | VALVE              | SOUPE/ROBINET      | VALVULA            | 1952-38-62-17  |     |
| 18       | 340 1359  | 1          | GEWINDESTIFT       | GRUB-SCREW         | GOUPILLE FILETEE   | PERNO ROSCADO      | 1952-08-62-18  |     |
| 19       | 340 1360  | 1          | DRUCKFEDER         | COMPRESSION SPRING | RESSORT DE COMPR   | RESORTE PRESION    | 1952-08-62-19  |     |
| 22       | 116 9761  | 1          | O-RING             | O-SEAL             | BAGUE TORIQUE      | ANILLO O           | 10 X2 H 2927-GI DEUTZ 9                                | 01  |
| 24       | 340 0830  | 1          | SICHERHEITSVENTIL  | SAFETY VALVE       | SOUPE SECURITE     | VALVULA SEGURIDAD  | 1941-38-26-10<br>8347-VOLLSTAENDIG MIT POSIT.<br>63-66 |     |
| 25       | 116 9764  | 2          | O-RING             | O-SEAL             | BAGUE TORIQUE      | ANILLO O           | 22 X2 H 2927-GI DEUTZ 9                                | 01  |
| 26       | 116 9763  | 2          | O-RING             | O-SEAL             | BAGUE TORIQUE      | ANILLO O           | 18 X2 H 2927-GI DEUTZ 9                                | 01  |
| 27       | 110 1402  | 1          | ZYLINDERSTIFT      | PARALLEL PIN       | GOUPILLE CYLINDR.  | PERNO CILINDRICO   | 4x6x 140IN 6325  |     |
| 31       | 111 8713  | 1          | DICHTRING          | WASHER             | BAGUE D ETANCHEITE | ANILLO DE JUNTA    | A 18 X 22 DIN 7603-CU                                  |     |
| 32       | 111 8956  | 1          | VERSCHLUSSSCHRAUBE | SCREW PLUG         | BOUCHON FILETE     | TAPON ROSCADO      | M12x1,5 DIN 7604 VZKC                                  |     |
| 33       | 111 8673  | 1          | DICHTRING          | WASHER             | BAGUE D ETANCHEITE | ANILLO DE JUNTA    | A 12 X 15,50IN 7603-CU                                 |     |

| Bd<br>Nr. | Teil-Nr. | Stück-<br>Zahl | Deutsch           | English            | Français           | Español            | Nummer/Bemerkung                                     | ETK |
|-----------|----------|----------------|-------------------|--------------------|--------------------|--------------------|--|-----|
| 34        | 110 0925 | 6              | ZYLINDERSCHRAUBE  | CHEESE-HEAD SCREW  | VIS TETE CYLINDR.  | TORN-CBZA-CILIND.  | M 5X 15DIN 932- 6-9 VZKC                             |     |
| 35        | 116 7193 | 6              | SICHERUNGSSCHEIBE | LOCKING WASHER     | RONDELLE SECURITE  | ARANDELA SEGURIDAD | 5 H 2203   |     |
| 36        | 110 2346 | 1              | VERSCHLUSSMUTTER  | CAP NUT            | ECROU BORGNE       | TUERCA DE CIERRE   | M14X1,5DIN 7605 VZKC                                 |     |
| 38        | 111 5333 | 1              | HALBRUNDKERBNAGEL | NOTCHED NAIL       | ERGOT A ENCOCHE    | CLAVIJA PANURADA   | 6 X11 DIN 1476 VZKC                                  |     |
| 39        | 110 2347 | 2              | VERSCHLUSSSCHEIBE | DISHED PLUG        | RONDELLE OBTURAT-  | ARANDELA CIERRE    | 14DIN 470 VZKC                                       |     |
| 41        | 111 5405 | 1              | SPANNHUELSE       | DOWEL SLEEVE       | DOUILLE SERRAGE    | CASQUILLO FIADOR   | 3 X 12DIN 1481                                       |     |
| 42        | 112 3958 | 2              | KUGEL             | BALL               | BILLE/BOULE        | BOLA               | 4,5M1 III DIN 5401                                   |     |
| 43        | 111 8688 | 2              | DICHRING          | WASHER             | BAGUE D ETANCHEITE | ANILLO DE JUNTA    | A 14 X 18 DIN 7603-CU                                |     |
| 47        | 231 1920 | 1              | KUGELBOLZEN       | BALL-END PIN       | BOULON A ROTULE    | BULON ESFERICO     |  |     |
| 49        | 116 0286 | 1              | EINSCHRAUBSTUTZEN | SCREW-IN NIPPLE    | TUBULURE A VIS     | TUBULAD-ENROSCADA  | M16X1,5X12 H 3132                                    |     |
| 51        | 231 8928 | 1              | REPARATURSATZ     | REPAIR KIT         | LOT DE REPARATION  | LOTE REPARACIONES  | 8347, VOLLSTAENDIG MIT POSIT.<br>4,5,22,25,26,41+43. |     |
| 54        | 233 3721 | 1              | SCHALTWELLE       | SHIFTING SHAFT     | ARBRE COMMANDE     | EJE MANDO/CAMBIO   |  |     |
| 55        | 339 1955 | 1              | HANDGRIFF         | HANDLE             | POIGNEE            | PUNO               | 1424-14-01-09  |     |
| 61        | 340 0825 | 1              | VENTILFUEHRUNG    | VALVE GUIDE        | GUIDE DE SOUPAPE   | GUIA DE VALVULA    | 1941-18-26-03  |     |
| 62        | 340 0827 | 1              | DRUCKFEDER        | COMPRESSION SPRING | RESSORT DE COMPR   | RESORTE PRESSION   | 1941-18-26-02  |     |
| 63        | 340 0828 | 1              | VENTILSTIFT       | VALVE PIN          | POINTEAU           | PERNO DE VALVULA   | 1941-18-26-04  |     |
| 64        | 116 9738 | 1              | SICHERUNGSRING    | CIRCLIP            | CIRCLIP            | CIRCLIP            | 18H 2371   |     |
| 65        | 340 0829 | 1              | BEILAGE           | SHIM               | CALE               | SUPLEMENTO         | 1941-18-26-07  |     |
| 66        | 230 9890 | 2              | VENTILTeller      | VALVE PLATE        | PLATEAU DE SOUPAPE | PLATO DE VALVULA   |  |     |

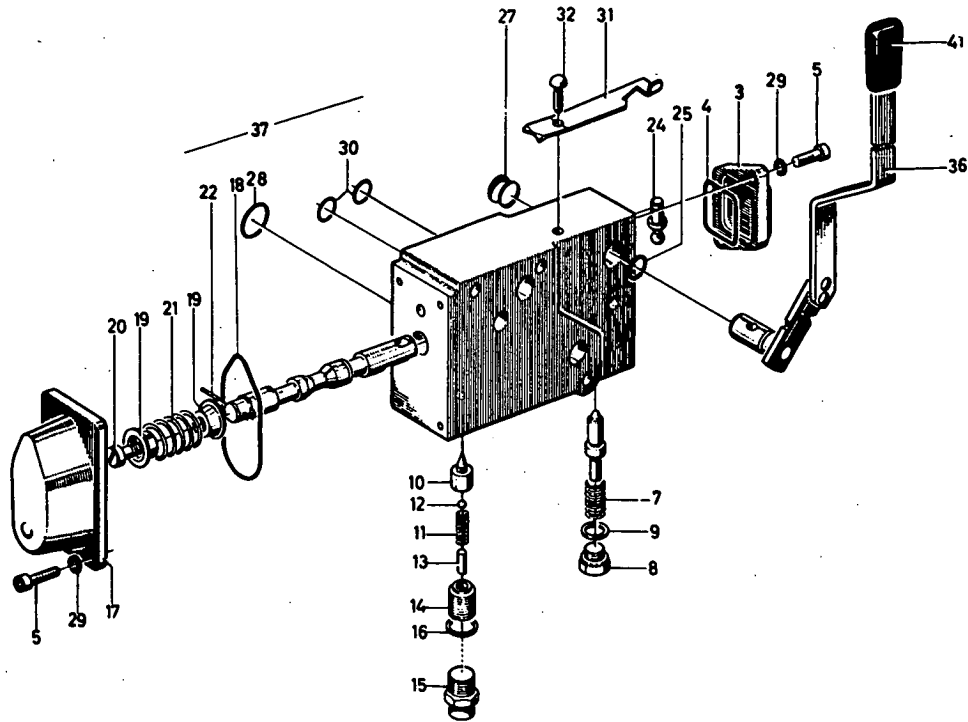

1804-40 500 5136

| Bild Nr. | Teil-Nr. | Stück-Zahl | Deutsch            | English            | Français           | Español            | Nummer / Bemerkung       | ETK |
|----------|----------|------------|--------------------|--------------------|--------------------|--------------------|--------------------------|-----|
| 1.       | 233 3730 | 1          | STEUERGERÄT        | CONTROL UNIT       | DISTRIBUTEUR       | APARATO MANDO      |                          |     |
| 2.       | 340 1349 | 1          | DECKEL             | COVER              | COUVERCLE          | TAPA               | 1952-08-62-03            |     |
| 4.       | 340 1351 | 1          | DICHTUNG           | GASKET             | GARNITURE/JOINT    | JUNTA              | 1952-08-62-05            | 01  |
| 5.       | 110 0925 | 6          | ZYLINDERSCHRAUBE   | CHEESE-HEAD SCREW  | VIS TETE CYLINDR.  | TORN-CBZA-CILINDR. | M 5X 15DIN 912- 6-9 VZKC |     |
| 7.       | 340 1344 | 1          | DRUCKFEDER         | COMPRESSION SPRING | RESSORT DE COMPR   | RESORTE PRESION    | 1952-08-61-16            |     |
| 8.       | 111 8756 | 1          | VERSCHLUSSSCHRAUBE | SCREW PLUG         | BOUCHON FILETE     | TAPON ROSCADO      | M12X1,5 DIN 7604 VZKC    |     |
| 9.       | 111 8673 | 1          | DICHRING           | WASHER             | BAGUE D ETANCHEITE | ANILLO DE JUNTA    | A 12 X 15,5DIN 7603-CU   |     |
| 10.      | 340 1358 | 1          | VENTIL             | VALVE              | SOUPAPE/ROBINET    | VALVULA            | 1952-08-62-17            |     |
| 11.      | 340 1360 | 1          | DRUCKFEDER         | COMPRESSION SPRING | RESSORT DE COMPR   | RESORTE PRESION    | 1952-08-62-19            |     |
| 12.      | 112 3958 | 1          | KUGEL              | BALL               | BILLE/BOULE        | BOLA               | 4,5MM III DIN 5401       |     |
| 13.      | 110 1402 | 1          | ZYLINDERSTIFT      | PARALLEL PIN       | GOUPILLE CYLINDR.  | PERNO CILINDRICO   | 4M6X 14DIN 6325          |     |
| 14.      | 340 1359 | 1          | GEWINDESTIFT       | GRUB SCREW         | GOUPILLE FILETEE   | PERNO ROSCADO      | 1952-08-62-18            |     |
| 15.      | 110 2346 | 1          | VERSCHLUSSMUTTER   | CAP NUT            | ECROU BORGNE       | TUERCA DE CIERRE   | M14X1,5DIN 7605 VZKC     |     |
| 16.      | 111 8688 | 1          | DICHRING           | WASHER             | BAGUE D ETANCHEITE | ANILLO DE JUNTA    | A 14 X 18 DIN 7603-CU    |     |
| 17.      | 340 1346 | 1          | DECKEL             | COVER              | COUVERCLE          | TAPA               | 1952-08-62-02            |     |
| 18.      | 340 1350 | 1          | DICHTUNG           | GASKET             | GARNITURE/JOINT    | JUNTA              | 1952-08-62-04            | 01  |
| 19.      | 340 1345 | 1          | FEDERTELLER        | SPRING CAP         | CUVETTE DE RESSORT | PLATO RESORTE      | 1952-08-61-17            |     |
| 20.      | 340 1340 | 1          | BOLZEN             | PIN/BOLT/STUD      | BOULON/AXE         | BULON              | 1952-08-61-09            |     |
| 21.      | 340 1343 | 1          | DRUCKFEDER         | COMPRESSION SPRING | RESSORT DE COMPR   | RESORTE PRESION    | 1952-08-61-15            |     |
| 22.      | 111 5405 | 1          | SPANNHUELSE        | DOWEL SLEEVE       | DOUILLE SERRAGE    | CASQUILLO FIADOR   | 3 X 12DIN 1481           |     |
| 24.      | 231 1920 | 1          | KUGELBOLZEN        | BALL-END PIN       | BOULON A ROTULE    | BULON ESFERICO     |                          |     |
| 25.      | 116 9761 | 1          | O-RING             | O-SEAL             | BAGUE TORIQUE      | ANILLO O           | 10 X2 H 2927-GI DEUTZ 9  | 01  |
| 27.      | 110 2347 | 2          | VERSCHLUSSSCHEIBE  | DISHED PLUG        | RONDELLE OBTURAT.  | ARANDELA CIERRE    | 14DIN 470 VZKC           |     |
| 28.      | 116 9764 | 1          | O-RING             | O-SEAL             | BAGUE TORIQUE      | ANILLO O           | 22 X2 H 2927-GI DEUTZ 9  | 01  |
| 29.      | 116 7193 | 6          | SICHERUNGSSCHEIBE  | LOCKING WASHER     | RONDELLE SECURITE  | ARANDELA SEGURIDAD | 5 H 2203                 |     |
| 30.      | 116 9763 | 2          | O-RING             | O-SEAL             | BAGUE TORIQUE      | ANILLO O           | 18 X2 H 2927-GI DEUTZ 9  | 01  |

| Bld<br>Nr. | Teil-Nr. | Stück-<br>Zahl | Deutsch           | English        | Français          | Español           | Nummer/Bemerkung                                 | ETK |
|------------|----------|----------------|-------------------|----------------|-------------------|-------------------|--|-----|
| 31         | 340 1352 | 1              | BLATTFEDER        | LEAF SPRING    | RESSORT A LAMES   | BALLESTA          | 1952-38-62-11                                    |     |
| 32         | 111 5333 | 1              | HALBRUNDKERBNAGEL | NOTCHED NAIL   | ERGOT A ENCOCHE   | CLAVIJA RANURADA  | 6 X11 DIN 1476 VZKC                              |     |
| 36         | 233 3721 | 1              | SCHALTWELLE       | SHIFTING SHAFT | ARBRE COMMANDE    | EJE MANDO/CAMBIO  |  |     |
| 37         | 231 8928 | 1              | REPARATURSATZ     | REPAIR KIT     | LOT DE REPARATION | LOTE REPARACIONES | 8347 VOLLSTAENDIG MIT POSIT.<br>4.16.22.25.28.30 |     |
| 41         | 339 1955 | 1              | HANDGRIFF         | HANDLE         | POIGNEE           | PUNO              | 1424-14-31-09                                    |     |

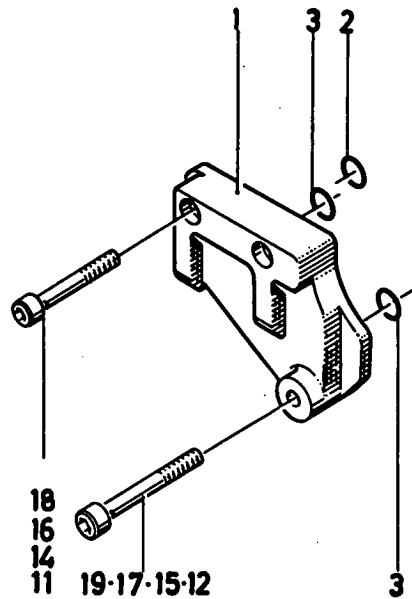

1804-40 500 5133

| Bild Nr. | Teil-Nr. | Stück-Zahl | Deutsch          | English           | Français          | Español           | Nummer/Bemerkung         | ETK |
|----------|----------|------------|------------------|-------------------|-------------------|-------------------|--------------------------|-----|
| 1        | 390 1283 | 1          | ENDSTUECK        | END PIECE         | PIECE DE BOUT     | PZA-FINAL         | 1952-08-22-35            |     |
| 2        | 116 9764 | 1          | O-RING           | O-SEAL            | BAGUE TORIQUE     | ANILLO O          | 22 X2 H 2927-6I DEUTZ 9  | 01  |
| 3        | 116 9763 | 2          | O-RING           | O-SEAL            | BAGUE TORIQUE     | ANILLO O          | 18 X2 H 2927-6I DEUTZ 9  | 01  |
| 11       | 112 3701 | 2          | ZYLINDERSCHRAUBE | CHEESE-HEAD SCREW | VIS TETE CYLINDR. | TORN.CBZA.CILIND. | M 8X 40DIN 912- 8-8 A4C  |     |
| 12       | 110 1405 | 1          | ZYLINDERSCHRAUBE | CHEESE-HEAD SCREW | VIS TETE CYLINDR. | TORN.CBZA.CILIND. | M 8X 50DIN 912- 8-8 A4C  |     |
| 14       | 111 0622 | 2          | ZYLINDERSCHRAUBE | CHEESE-HEAD SCREW | VIS TETE CYLINDR. | TORN.CBZA.CILIND. | M 8X 80DIN 912- 8-8-A4C  |     |
| 15       | 110 1406 | 1          | ZYLINDERSCHRAUBE | CHEESE-HEAD SCREW | VIS TETE CYLINDR. | TORN.CBZA.CILIND. | M 8X 90DIN 912- 8-8 A4C  |     |
| 16       | 112 3702 | 2          | ZYLINDERSCHRAUBE | CHEESE-HEAD SCREW | VIS TETE CYLINDR. | TORN.CBZA.CILIND. | M 8X 120DIN 912- 8-8 A4C |     |
| 17       | 110 1407 | 1          | ZYLINDERSCHRAUBE | CHEESE-HEAD SCREW | VIS TETE CYLINDR. | TORN.CBZA.CILIND. | M 8X 130DIN 912- 8-8 A4C |     |
| 18       | 110 2048 | 2          | ZYLINDERSCHRAUBE | CHEESE-HEAD SCREW | VIS TETE CYLINDR. | TORN.CBZA.CILIND. | M 8X 160DIN 912- 8-8-A4C |     |
| 19       | 112 3703 | 1          | ZYLINDERSCHRAUBE | CHEESE-HEAD SCREW | VIS TETE CYLINDR. | TORN.CBZA.CILIND. | M 8X 170DIN 912-10-9-A4C |     |

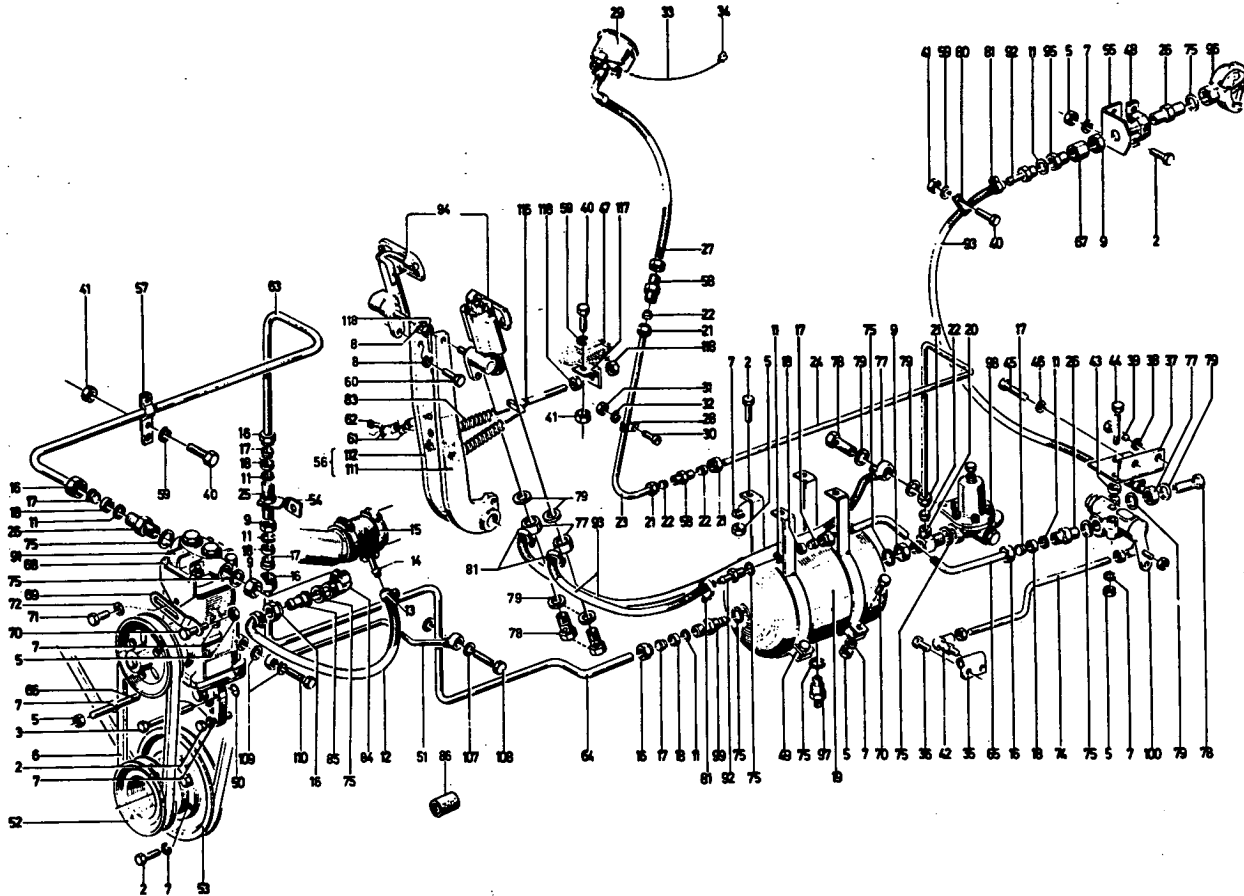

1941-55 500 6315

| Bld Nr. | Teil-Nr. | Stück-Zahl | Deutsch           | English            | Français           | Español            | Nummer/Bemerkung         | ETK |
|---------|----------|------------|-------------------|--------------------|--------------------|--------------------|--------------------------|-----|
| 2       | 111 2333 | 16         | SECHSKANTSCHRAUBE | HEX-BOLT           | VIS 6 PANS         | TORNILLO HEXAGONAL | M 8X 25 DIN 933- 8-8-A4C |     |
| 3       | 111 1200 | 1          | SECHSKANTSCHRAUBE | HEX-BOLT           | VIS 6 PANS         | TORNILLO HEXAGONAL | M 8X 90 DIN 933- 8-8-A4C |     |
| 5       | 111 2824 | 9          | SECHSKANTMUTTER   | HEX-NUT            | ECROU 6 PANS       | TUERCA HEXAGONAL   | M 8 DIN 934-M 8 A4C      |     |
| 6       | 116 2717 | 1          | SCHMALKEILRIEMEN  | V-BELT             | COURR TRAP ETROITE | CORR-TRAPEC-ESTREC | 12,5X1025H 3701          | 01  |
| 7       | 110 2777 | 20         | FEDERRING         | SPRING LOCKWASHER  | RONDELLE GROWER    | ARANDELA ELASTICA  | A 8 DIN 128 A4C          |     |
| 8       | 110 2800 | 2          | FEDERRING         | SPRING LOCKWASHER  | RONDELLE GROWER    | ARANDELA ELASTICA  | A 10 DIN 128 A4C         |     |
| 9       | 112 3543 | 4          | SECHSKANTMUTTER   | HEX-NUT            | ECROU 6 PANS       | TUERCA HEXAGONAL   | M22X1,5DIN74305 VZKC     |     |
| 11      | 112 1715 | 6          | DICHRING          | WASHER             | BAGUE D ETANCHEITE | ANILLO DE JUNTA    | D12 DIN74297             |     |
| 12      | 112 1774 | HTR        | BREMSCHLAUCH      | BRAKE HOSE         | FLEXIBLE DE FREIN  | MANGUERA FRENO     | 13 DIN74310              | 01  |
| 13      | 112 3545 | 2          | SCHLAUCHSCHELLE   | HOSE CLIP          | COLLIER SERRAGE    | ABRAZADERA MANGUER | 25DIN74306 VZKC          |     |
| 14      | 340 0437 | 1          | SAUGANSCHLUSS     | INTAKE             | RACCORD ASPIR      | EMPALME ASPIRACION | 1941-55-22-10            |     |
| 15      | 112 8264 | 2          | SCHLAUCHSCHELLE   | HOSE CLIP          | COLLIER SERRAGE    | ABRAZADERA MANGUER | SA 70- 90DIN 3017-W1     |     |
| 16      | 112 1705 | 7          | UEBERWURFMUTTER   | UNION NUT          | ECROU-RACCORD      | TUERCA EMPALME     | M22X1,5DIN74297 VZKC     |     |
| 17      | 112 1709 | 6          | SCHLUEPFRING      | SLIP RING          | ANNEAU EXPANSIBLE  | ANILLO EXPANS      | 815 DIN74297             |     |
| 18      | 112 1712 | 6          | BRUCKRING         | THRUST RING        | BAGUE DE BUTEE     | ANILLO PRESSION    | C15 DIN74297             |     |
| 19      | 231 9922 | 1          | LUFTBEHAELTER     | AIR BOTTLE         | RESERVOIR D AIR    | BOTELLON AIRE      |                          |     |
| 20      | 112 3538 | 1          | T-STUECK          | T-PIECE            | PIECE T            | PIEZA EN T         | M22X1,5DIN74302 VZKC     |     |
| 21      | 112 3530 | 4          | UEBERWURFMUTTER   | UNION NUT          | ECROU-RACCORD      | TUERCA EMPALME     | M12X1,5DIN74297 VZKC     |     |
| 22      | 112 1707 | 4          | SCHLUEPFRING      | SLIP RING          | ANNEAU EXPANSIBLE  | ANILLO EXPANS      | 8 6 DIN74297             |     |
| 23      | 232 7242 | 1          | DRUCKLEITUNG      | DELIVERY LINE      | CONDUITE DE REFOL  | TUBERIA PRESSION   |                          |     |
| 24      | 232 7243 | 1          | DRUCKLEITUNG      | DELIVERY LINE      | CONDUITE DE REFOL  | TUBERIA PRESSION   |                          |     |
| 25      | 112 1735 | 1          | DOPPELSTUTZEN     | TWIN NIPPLE        | TUBULURE DOUBLE    | TUBULAD-DOBLE      | M22X1,5DIN74299 VZKC     |     |
| 26      | 112 5504 | 4          | DOPPELSTUTZEN     | TWIN NIPPLE        | TUBULURE DOUBLE    | TUBULAD-DOBLE      | 8M22X1,5DIN74299 VZKC    |     |
| 27      | 340 0705 | 1          | SCHLAUCH          | HOSE               | FLEXIBLE           | MANGUERA           | 1940-55-03-93            | 01  |
| 28      | 112 3476 | 3          | SHELLE            | CLIP               | COLLIER            | ABRAZADERA         | 6 DIN72572 VZKC          |     |
| 29      | 231 3376 | 1          | LUFTDRUCKMESSER   | AIR PRESSURE GAUGE | MANOMETRE          | MANOMETRO AIRE     |                          |     |

| Bld Nr. | Teile-Nr. | Stück-Zahl | Deutsch            | English           | Français           | Español            | Numer/Bemerkung           | ETK |
|---------|-----------|------------|--------------------|-------------------|--------------------|--------------------|---------------------------|-----|
| 30      | 110 5512  | 3          | ZYLINDERSCHRAUBE   | CHEESE-HEAD SCREW | VIS TETE CYLINDR.  | TORN.CBZA.CILIND.  | M 4 X 12 DIN 84- 4.8-A4C  |     |
| 31      | 111 2796  | 3          | SECHSKANTMUTTER    | HEX.NUT           | ECROU 6 PANS       | TUERCA HEXAGONAL   | M 4 DIN 934-M 8 A4C       |     |
| 32      | 110 2795  | 3          | FEDERRING          | SPRING LOCKWASHER | RONDELLE GROWER    | ARANDELA ELASTICA  | A 4 DIN 128 A4C           |     |
| 33      | 390 0945  | 1          | LEITUNG            | PIPE/LINE/LEAD    | CONDUITE           | TUBERIA/CONDUCTO   | 1941-55-29-10             |     |
| 34      | 116 9070  | 1          | KLEMMBLECH         | CLAMPING SHEET    | TOLE DE SERRAGE    | CHAPA APRIETO      | 1 BCL H 7602              |     |
| 35      | 340 0922  | 2          | BLECH              | PLATE             | TOLE               | CHAPA              | 1941-55-01-75             |     |
| 36      | 111 2322  | 1          | SECHSKANTSCHRAUBE  | HEX-BOLT          | VIS 6 PANS         | TORNILLO HEXAGONAL | M 8X 20 DIN 933- 8.8-A4C  |     |
| 37      | 340 0923  | 1          | KONSOLE            | BRACKET/CONSOLE   | CONSOLE            | CONSOLA            | 1941-55-01-82             |     |
| 38      | 110 2801  | 2          | FEDERRING          | SPRING LOCKWASHER | RONDELLE GROWER    | ARANDELA ELASTICA  | A 12 DIN 128 A4C          |     |
| 39      | 111 2515  | 1          | SECHSKANTSCHRAUBE  | HEX.BOLT          | VIS 6 PANS         | TORNILLO HEXAGONAL | M12X 25 DIN 933-M 8.8-A4C |     |
| 40      | 111 2240  | 4          | SECHSKANTSCHRAUBE  | HEX.BOLT          | VIS 6 PANS         | TORNILLO HEXAGONAL | M 6X 12 DIN 933- 8.8-A4C  |     |
| 41      | 111 2813  | 7          | SECHSKANTMUTTER    | HEX.NUT           | ECROU 6 PANS       | TUERCA HEXAGONAL   | M 6 DIN 934-M 8 A4C       |     |
| 42      | 112 0936  | 2          | WINKELGELENK       | ANGLE JOINT       | ARTICULAT.D ANGLE  | ARTICULAC-ANGULAR  | A 10 DIN71802 VZKC        |     |
| 43      | 337 2999  | 2          | ZWISCHENROHR       | ADAPTER TUBE      | TUBE INTERMEDIAIRE | TUBO INTERMEDIO    | 1452-77-07-04             |     |
| 44      | 111 1179  | 2          | SECHSKANTSCHRAUBE  | HEX.BOLT          | VIS 6 PANS         | TORNILLO HEXAGONAL | M 8X 70 DIN 933- 8.8-A4C  |     |
| 45      | 111 2636  | 1          | SECHSKANTSCHRAUBE  | HEX.BOLT          | VIS 6 PANS         | TORNILLO HEXAGONAL | M14X 50 DIN 933-M 8.8 A4C |     |
| 46      | 110 2802  | 1          | FEDERRING          | SPRING LOCKWASHER | RONDELLE GROWER    | ARANDELA ELASTICA  | A 14 DIN 128 A4C          |     |
| 48      | 112 3529  | 1          | BEFESTIGUNGSKLENNE | CLIP              | BORNE DE FIXATION  | BORNE FIJACION     | C DIN74294 VZKC           |     |
| 49      | 231 9885  | 2          | HALTER             | RETAINER          | SUPPORT/PORTEUTIL  | SOPORTE            |                           |     |
| 50      | 116 6016  | 1          | RUNDGUMRING        | O-SEAL            | ANNEAU TORIQUE     | ANILLO GOMA REDOND | 18 X 3 H 721              | 01  |
| 51      | 336 3646  | 1          | DRUCKOELLEITUNG    | HYDRAULIC LINE    | COND D HUILE FORC  | TUBER-ACEITE PRES. | 0150-33-405-40            |     |
| 52      | 230 0750  | 1          | KEILRIEMENSCHLEIBE | V-BELT PULLE      | POULIE COURR TRAP  | POLEA ACANALADA    |                           |     |
| 53      | 213 9336  | 1          | KEILRIEMENSCHLEIBE | V-BELT PULLE      | POULIE COURR TRAP  | POLEA ACANALADA    |                           |     |
| 54      | 231 9925  | 1          | HALTER             | RETAINER          | SUPPORT/PORTEUTIL  | SOPORTE            |                           |     |
| 55      | 231 9844  | 1          | HALTER             | RETAINER          | SUPPORT/PORTEUTIL  | SOPORTE            |                           |     |
| 56      | 231 9909  | 1          | BREMSPEDAL         | BRAKE PEDAL       | PEDALE DE FREIN    | PEDAL FRENO        |                           |     |
| 57      | 231 9876  | 1          | HALTER             | RETAINER          | SUPPORT/PORTEUTIL  | SOPORTE            |                           |     |
| 58      | 112 1721  | 2          | DOPELSTUTZEN       | TWIN NIPPLE       | TUBULURE DOUBLE    | TUBULAD-DOBLE      | M12X1.5DIN74298           |     |
| 59      | 110 2797  | 5          | FEDERRING          | SPRING LOCKWASHER | RONDELLE GROWER    | ARANDELA ELASTICA  | A 6 DIN 128 A4C           |     |
| 60      | 111 2407  | 2          | SECHSKANTSCHRAUBE  | HEX-BOLT          | VIS 6 PANS         | TORNILLO HEXAGONAL | M10X 20 DIN 933- 8.8-A4C  |     |
| 61      | 112 1285  | 2          | SCHELLE            | CLIP              | COLLIER            | ABRAZADERA         | 15 DIN72572               |     |
| 62      | 111 2215  | 1          | SECHSKANTSCHRAUBE  | HEX-BOLT          | VIS 6 PANS         | TORNILLO HEXAGONAL | M 5X 20 DIN 933- 8.8-A4C  |     |
| 63      | 231 9939  | 1          | DRUCKLEITUNG       | DELIVERY LINE     | CONDUITE DE REFOUL | TUBERIA PRESSION   |                           |     |
| 64      | 232 9244  | 1          | DRUCKLEITUNG       | DELIVERY LINE     | CONDUITE DE REFOUL | TUBERIA PRESSION   |                           |     |
| 65      | 232 9245  | 1          | DRUCKLEITUNG       | DELIVERY LINE     | CONDUITE DE REFOUL | TUBERIA PRESSION   |                           |     |
| 66      | 111 3427  | 1          | STIFTSCHRAUBE      | STUD              | GOUJON             | ESPARRAGO          | M 8 X 85 DIN 939- 6.8-A4C |     |
| 67      | 230 1124  | 1          | MUFFE              | SLEEVE            | MANCHON            | MANGUITO           |                           |     |
| 68      | 232 9208  | 1          | HALTER             | RETAINER          | SUPPORT/PORTEUTIL  | SOPORTE            |                           |     |
| 69      | 232 9211  | 1          | LASCHE             | CONNECTING PLATE  | ECLISSE            | ECLISA             |                           |     |
| 70      | 111 2350  | 3          | SECHSKANTSCHRAUBE  | HEX-BOLT          | VIS 6 PANS         | TORNILLO HEXAGONAL | M 8X 35 DIN 933- 8.8-A4C  |     |
| 71      | 111 2305  | 1          | SECHSKANTSCHRAUBE  | HEX-BOLT          | VIS 6 PANS         | TORNILLO HEXAGONAL | M 8X 15 DIN 933- 8.8-A4C  |     |
| 72      | 110 7101  | 1          | SCHLEIBE           | DISC/PANE/PLATE   | RONDELLE/DISQUE    | DISCO              | A 8.4DIN 125-ST-A4C       |     |
| 74      | 232 9252  | 1          | DRUCKSTANGE        | THRUST ROD        | BRAS DE LEVIER     | VARILLA PRESSION   |                           |     |
| 75      | 111 8737  | 10         | DICHTRING          | WASHER            | BAGUE D ETANCHEITE | ANILLO DE JUNTA    | A 22 X 27 DIN 7603-CU     |     |
| 77      | 121 2742  | 4          | RINGSTUECK         | BANJO FITTING     | PIECE ANNULAIRE    | PZA-ANULAR         | 3 450 A                   |     |
| 78      | 111 9276  | 4          | HOHLSCHRAUBE       | BANJO BOLT        | VIS BANJO          | TORNILLO RACOR     | M24DIN 7967               |     |
| 79      | 111 8688  | 8          | DICHTRING          | WASHER            | BAGUE D ETANCHEITE | ANILLO DE JUNTA    | A 14 X 18 DIN 7603-CU     |     |
| 80      | 116 8145  | 1          | ROHRSCHLEIBE       | PIPE CLIP         | COLLIER PR TUBES   | ABRAZADERA DE TUBO | B15 H 3201                |     |
| 81      | 112 8263  | 6          | SCHLAUCHSCHLEIBE   | HOSE CLIP         | COLLIER SERRAGE    | ABRAZADERA MANGUER | LA 10- 16DIN 3017-W1      |     |
| 83      | 232 5877  | 2          | ZUGFEDER           | DRUM SPRING       | RESSORT TRACTION   | RESORTE TRACCION   |                           | 01  |
| 84      | 112 3537  | 1          | WINKELSTUECK       | ANGLE PIECE       | PIECE COUDEE       | PIEZA ANGULAR      | M22X1.5DIN74301-A4C       |     |
| 85      | 112 3539  | 1          | SCHLAUCHSTUTZEN    | HOSE NIPPLE       | RACCORD FLEXIBLE   | TUBULAD-MANGUERA   | A DIN74304 VZKC           |     |

| Bld<br>Nr. | Teil-Nr. | Stück-<br>Zahl | Deutsch            | English          | Français           | Español            | Numer/Bemerkung        | ETK |
|------------|----------|----------------|--------------------|------------------|--------------------|--------------------|------------------------|-----|
| 86         | 237 2477 | 1              | STOPFEN            | PLUG             | BOUCHON            | TAPON              |                        |     |
| 91         | 231 9833 | 1              | LUFTPRESSER        | AIR COMPRESSOR   | COMPRESSEUR D AIR  | COMPRESOR AIRE     |                        |     |
| 92         | 230 1131 | 2              | SCHLAUCHSTUTZEN    | HOSE NIPPLE      | RACCORD FLEXIBLE   | TUBULAD-MANGUERA   |                        |     |
| 93         | 139 3288 | MTR            | SCHLAUCH           | HOSE             | FLEXIBLE           | MANGUERA           |                        | 01  |
| 94         | 232 9142 | 1              | BREMSVENTIL        | BRAKE VALVE      | SOUPAPE DE FREIN   | VALV-FRENO         |                        |     |
| 95         | 230 1129 | 4              | REDUZIERVERSCHRAUB | REDUCER          | RACCORD REDUCTEUR  | REDUCTOR ROSCADO   |                        |     |
| 96         | 231 9839 | 1              | KUPPLUNGSKOPF      | COUPLING         | TETE D ACCOUPLEM   | CABEZA ACOPL-      |                        |     |
| 97         | 126 0634 | 1              | ENTWAESSER-VENTIL  | DRAIN VALVE      | SOUP PURGE D EAU   | VALV-DESAGUE       |                        |     |
| 98         | 232 4347 | 1              | BRUCKBEGR-VENTIL   | RELIEF VALVE     | LIMITEUR DE PRESS  | VAL-LIMIT-PRESION  |                        |     |
| 99         | 231 9838 | 1              | RUECKSCHLAGVENTIL  | CHECK VALVE      | SOUPAPE RETENUE    | VALV. DE RETENCION |                        |     |
| 100        | 340 0943 | 1              | HANDBREMSVENTIL    | HAND BRAKE VALVE | VALVE FREIN MANU   | VALV-FRENO MANO    | 1941-55-27-10          |     |
| 107        | 111 8673 | 2              | DICHRING           | WASHER           | BAGUE D ETANCHEITE | ANILLO DE JUNTA    | A 12 X 15,5DIN 7603-CU |     |
| 108        | 111 9238 | 1              | HOHLSCHRAUBE       | BANJO BOLT       | VIS BANJO          | TORNILLO RACOR     | A 6 DIN 7623           |     |
| 109        | 111 8659 | 2              | DICHRING           | WASHER           | BAGUE D ETANCHEITE | ANILLO DE JUNTA    | A 10 X 13,5DIN 7603-CU |     |
| 110        | 111 9235 | 1              | HOHLSCHRAUBE       | BANJO BOLT       | VIS BANJO          | TORNILLO RACOR     | A 4 DIN 7623           |     |
| 111        | 231 9905 | 1              | BREMSPEDAL         | BRAKE PEDAL      | PEDALE DE FREIN    | PEDAL FRENO        | 8195-LINKS             |     |
| 112        | 231 9907 | 1              | BREMSPEDAL         | BRAKE PEDAL      | PEDALE DE FREIN    | PEDAL FRENO        | 8267-RECHTS            |     |
| 116        | 232 9260 | 1              | SPANNSCHRAUBE      | CLAMPING BOLT    | VIS DE TENSION     | TORNILLO FIJAC-    |                        |     |
| 117        | 232 9262 | 1              | WINKEL             | ANGLE PLATE      | EQUERRE            | ANGULO             |                        |     |
| 118        | 110 2659 | 2              | SECHSKANTHUTTER    | HEX-NUT          | ECROU 6 PANS       | TUERCA HEXAGONAL   | M10 DIN 934-M 8 ANC    |     |





ZWEILEITUNGS-DRUCKLUFTANLAGE  
 PNEUMATIC SYSTEM, TWO-CIRCUIT  
 SYSTEME D'AIR COMPRIMÉ À DEUX CONDUITES  
 SISTEMA DE AIRE COMPRIMIDO, DE DOS CONDUCTOS

1941-55 500 4264

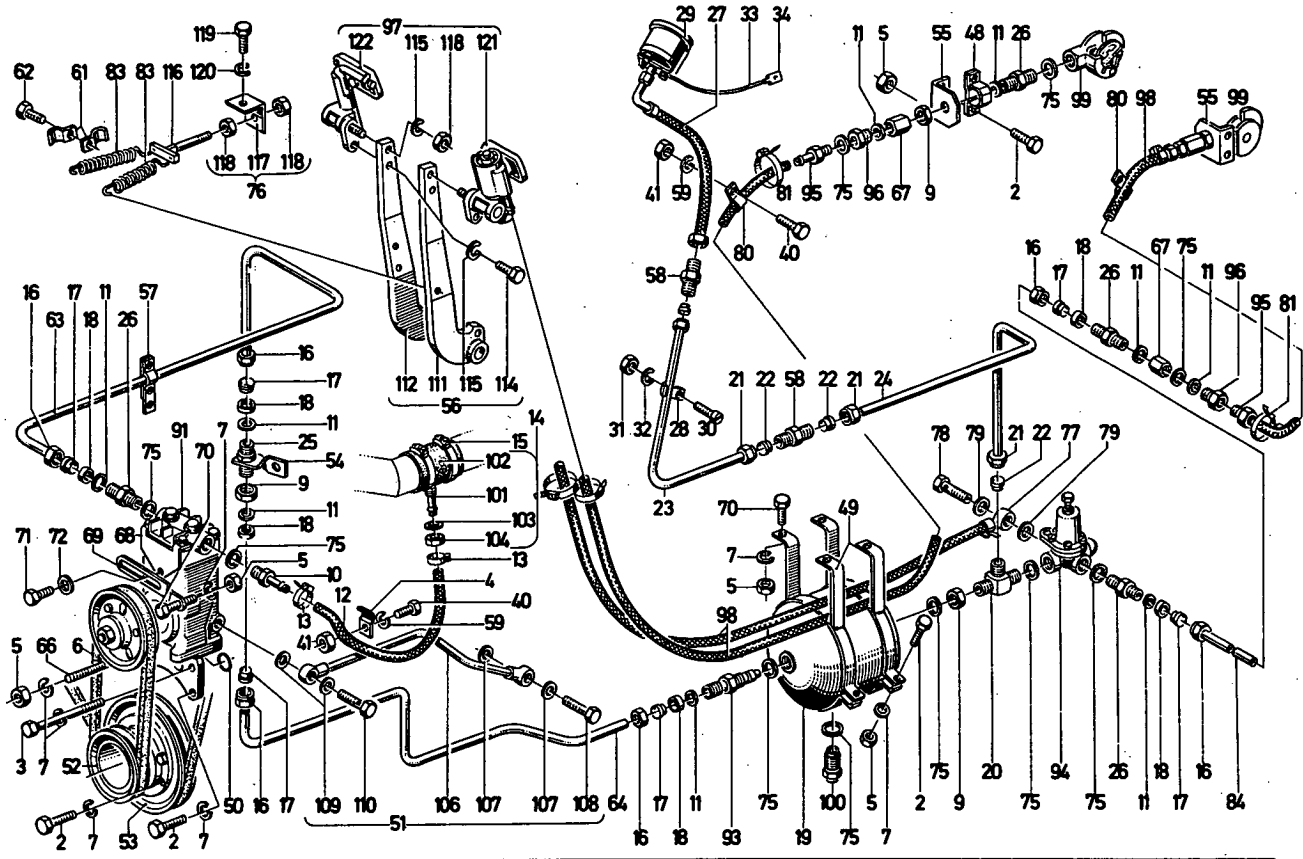

1941-55 500 4264

| Bild Nr. | Teile-Nr. | Stück-Zahl | Deutsch           | English           | Français           | Español             | Nummer / Bemerkung        | ETK |
|----------|-----------|------------|-------------------|-------------------|--------------------|---------------------|---------------------------|-----|
| 2        | 111 2333  | 16         | SECHSKANTSCHRAUBE | HEX-BOLT          | VIS 6 PANS         | TORNILLO HEXAGONAL  | M 8 X 25 DIN 933- 6-8-A4C |     |
| 3        | 111 1200  | 1          | SECHSKANTSCHRAUBE | HEX-BOLT          | VIS 6 PANS         | TORNILLO HEXAGONAL  | M 8 X 90 DIN 931- 6-8-A4C |     |
| 4        | 123 5136  | 1          | ROHRSCHELLE       | PIPE CLIP         | COLLIER PR TUBES   | ABRAZADERA DE TUBO  | CN 3145                   |     |
| 5        | 111 2824  | 7          | SECHSKANTMUTTER   | HEX-NUT           | ECROU 6 PANS       | TUERCA HEXAGONAL    | M 8 DIN 934-M 8 A4C       |     |
| 6        | 116 2717  | 1          | SCHWALKEILRIEMEN  | V-BELT            | COURR TRAP ETROITE | CORR-TRAPECE-ESTREC | 12,5X1025H 3701           | 01  |
| 7        | 110 2799  | 20         | FEDERRING         | SPRING LOCKWASHER | RONDELLE GROWER    | ARANDELA ELASTICA   | A 8 DIN 128 A4C           |     |
| 9        | 112 3543  | 4          | SECHSKANTMUTTER   | HEX-NUT           | ECROU 6 PANS       | TUERCA HEXAGONAL    | M22X1,5DIN74305 VZKC      |     |
| 10       | 112 3542  | 1          | SCHLAUCHSTUTZEN   | HOSE NIPPLE       | RACCORD FLEXIBLE   | TUBULAD-MANGUERA    | 8M22X1,5DIN74304 VZKC     |     |
| 11       | 112 1735  | 6          | DICHTRING         | WASHER            | BAGUE D ETANCHEITE | ANILLO DE JUNTA     | D12 DIN74297              |     |
| 12       | 112 1774  | MTR        | BREMSSCHLAUCH     | BRAKE HOSE        | FLEXIBLE DE FREIN  | MANGUERA FRENO      | 13 DIN74310               | 01  |
| 13       | 112 3545  | 2          | SCHLAUCHSCHELLE   | HOSE CLIP         | COLLIER SERRAGE    | ABRAZADERA MANGUER  | 25DIN74306 VZKC           |     |
| 14       | 340 0937  | 1          | ANSCHLUSSSTUECK   | CONNECTOR         | PIECE DE RACCORDEN | PZA-LIGACION        | 1941-55-22-10             |     |
| 15       | 112 8264  | 2          | SCHLAUCHSCHELLE   | HOSE CLIP         | COLLIER SERRAGE    | ABRAZADERA MANGUER  | S 80X15 H 735             |     |
| 16       | 112 1705  | 6          | UEBERWURFMUTTER   | UNION NUT         | ECROU-RACCORD      | TUERCA EMPALME      | AM22X1,5DIN74297 VZKC     |     |
| 17       | 112 1709  | 6          | SCHLUEPFRING      | SLIP RING         | ANNEAU EXPANSIBLE  | ANILLO EXPANS       | B15 DIN74297              |     |
| 18       | 112 1712  | 6          | DRUCKRING         | THRUST RING       | BAGUE DE BUTEE     | ANILLO PRESSION     | C15 DIN74297              |     |
| 19       | 231 3397  | 1          | LUFTBEHAELTER     | AIR BOTTLE        | RESERVOIR D AIR    | BOTELLON AIRE       |                           |     |
| 20       | 112 3538  | 1          | T-STUECK          | T-PIECE           | PIECE T            | PIEZA EN T          | CM22X1,5DIN74302 VZKC     |     |
| 21       | 112 3530  | 4          | UEBERWURFMUTTER   | UNION NUT         | ECROU-RACCORD      | TUERCA EMPALME      | AM12X1,5DIN74297 VZKC     |     |
| 22       | 112 1707  | 4          | SCHLUEPFRING      | SLIP RING         | ANNEAU EXPANSIBLE  | ANILLO EXPANS       | B 6 DIN74297              |     |
| 23       | 232 9242  | 1          | DRUCKLEITUNG      | DELIVERY LINE     | CONDUITE DE REFOUL | TUBERIA PRESSION    |                           |     |
| 24       | 232 9243  | 1          | DRUCKLEITUNG      | DELIVERY LINE     | CONDUITE DE REFOUL | TUBERIA PRESSION    |                           |     |
| 25       | 112 1735  | 1          | DOPELSTUTZEN      | TWIN NIPPLE       | TUBULURE DOUBLE    | TUBULAD-DOBLE       | CM22X1,5DIN74299 VZKC     |     |
| 26       | 112 5504  | 4          | DOPELSTUTZEN      | TWIN NIPPLE       | TUBULURE DOUBLE    | TUBULAD-DOBLE       | 8M22X1,5DIN74299 VZKC     |     |
| 27       | 340 0705  | 1          | SCHLAUCH          | HOSE              | FLEXIBLE           | MANGUERA            | 1940-55-03-93             | 01  |
| 28       | 112 3496  | 3          | SCHFELLE          | CLIP              | COLLIER            | ABRAZADERA          | 6 DIN72572 VZKC           |     |

| Bld Nr. | Tele-Nr. | Stück-Zahl | Deutsch            | English           | Français           | Español            | Nummer/Bemerkung           | ETK |
|---------|----------|------------|--------------------|-------------------|--------------------|--------------------|----------------------------|-----|
| 29      | 231 3376 | 1          | LUFTDRUCKPRUEFER   | TYRE GAUGE        | DISP CONTR GONFLAG | VERIFIC-PRES-AIRE  |                            |     |
| 30      | 110 5512 | 3          | ZYLINDERSCHRAUBE   | CHEESE-HEAD SCREW | VIS TETE CYLINDR.  | TORN-CBZA-CILIND.  | AM 4 X 12DIN 84- 4-8-A4C   |     |
| 31      | 111 2796 | 3          | SECHSKANTMUTTER    | HEX-NUT           | ECROU 6 PANS       | TUERCA HEXAGONAL   | M 4 DIN 934-M 8 A4C        |     |
| 32      | 110 2795 | 3          | FEDERRING          | SPRING LOCKWASHER | RONDELLE GROWER    | ARANDELA ELASTICA  | A 4 DIN 128 A4C            |     |
| 33      | 340 0495 | 1          | LEITUNG            | LINE/LEAD         | CONDUCTEUR         | CONDUCTOR          | 1943-55-29-10              |     |
| 34      | 116 9070 | 1          | VERTEILER          | DISTRIBUTOR       | DISTRIBUTEUR       | DISTRIBUIDOR/DELCO | 1 BCB H 7602               |     |
| 40      | 111 2240 | 4          | SECHSKANTSCHRAUBE  | HEX-BOLT          | VIS 6 PANS         | TORNILLO HEXAGONAL | M 6X 12 DIN 933- 8-8-A4C   |     |
| 41      | 111 2813 | 4          | SECHSKANTMUTTER    | HEX-NUT           | ECROU 6 PANS       | TUERCA HEXAGONAL   | M 6 DIN 934-M 8 A4C        |     |
| 48      | 112 3529 | 2          | BEFESTIGUNGSKLEMME | CLIP              | BORNE DE FIXATION  | BORNE FIJACION     | C DIN74294 VZKC            |     |
| 49      | 231 9885 | 2          | HALTER             | RETAINER          | SUPPORT/PORTEUTIL  | SOPORTE            |                            |     |
| 50      | 116 6016 | 1          | RUNDGUMMRING       | O-SEAL            | ANNEAU TORIQUE     | ANILLO GOMA REDOND | 18 X 3 H 721               | 01  |
| 51      | 336 3646 | 1          | DRUCKLEITUNG       | HYDRAULIC LINE    | COND D HUILE FORC  | TUBER-ACEITE PRES. | 0150-33-405-40             |     |
| 52      | 230 0750 | 1          | KEILRIEMENSCHLEIBE | V-BELT PULLE      | POULIE COURR TRAP  | POLEA ACANALADA    |                            |     |
| 53      | 213 4336 | 1          | KEILRIEMENSCHLEIBE | V-BELT PULLE      | POULIE COURR TRAP  | POLEA ACANALADA    |                            |     |
| 54      | 231 9725 | 1          | HALTER             | RETAINER          | SUPPORT/PORTEUTIL  | SOPORTE            |                            |     |
| 55      | 231 9844 | 2          | HALTER             | RETAINER          | SUPPORT/PORTEUTIL  | SOPORTE            |                            |     |
| 56      | 231 9709 | 1          | BREMSPEDAL         | BRAKE PEDAL       | PEDALE DE FREIN    | PEDAL FRENO        |                            |     |
| 57      | 231 9876 | 1          | HALTER             | RETAINER          | SUPPORT/PORTEUTIL  | SOPORTE            |                            |     |
| 58      | 112 1721 | 2          | DOPPELSTUTZEN      | TWIN NIPPLE       | TUBULURE DOUBLE    | TUBULAD-DOBLE      | M12X1.5DIN74298            |     |
| 59      | 110 2797 | 6          | FEDERRING          | SPRING LOCKWASHER | RONDELLE GROWER    | ARANDELA ELASTICA  | A 6 DIN 128 A4C            |     |
| 61      | 112 1285 | 2          | SCHELLE            | CLIP              | COLLIER            | ABRAZADERA         | 15 DIN72572                |     |
| 62      | 111 2215 | 1          | SECHSKANTSCHRAUBE  | HEX-BOLT          | VIS 6 PANS         | TORNILLO HEXAGONAL | M 5X 20 DIN 933- 8-8-A4C   |     |
| 63      | 231 9739 | 1          | DRUCKLEITUNG       | DELIVERY LINE     | CONDUITE DE REFOUL | TUBERIA PRESSION   |                            |     |
| 64      | 233 3263 | 1          | DRUCKLEITUNG       | DELIVERY LINE     | CONDUITE DE REFOUL | TUBERIA PRESSION   |                            |     |
| 66      | 111 3427 | 1          | STIFTSCHRAUBE      | STUD              | GOUJON             | ESPARRAGO          | AM 8X 85 DIN 934- 6-8 VZKC |     |
| 67      | 230 1124 | 3          | MUFFE              | SLEEVE            | MANCHON            | MANGUITO           |                            |     |
| 68      | 232 9208 | 1          | HALTER             | RETAINER          | SUPPORT/PORTEUTIL  | SOPORTE            |                            |     |
| 69      | 232 9211 | 1          | LASCHE             | CONNECTING PLATE  | ECLISSE            | ECLISA             |                            |     |
| 70      | 111 2350 | 5          | SECHSKANTSCHRAUBE  | HEX-BOLT          | VIS 6 PANS         | TORNILLO HEXAGONAL | M 8X 35 DIN 933- 8-8-A4C   |     |
| 71      | 111 2305 | 1          | SECHSKANTSCHRAUBE  | HEX-BOLT          | VIS 6 PANS         | TORNILLO HEXAGONAL | M 8X 15 DIN 933- 8-8-A4C   |     |
| 72      | 110 7101 | 1          | SCHLEIBE           | DISC/PANE/PLATE   | RONDELLE/DISQUE    | DISCO              | A 8-4DIN 125-ST-A4C        |     |
| 75      | 111 8737 | 8          | DICHTRING          | WASHER            | BAGUE D ETANCHEITE | ANILLO DE JUNTA    | A 22 X 27 DIN 7603-CU      |     |
| 76      | 232 9263 | 1          | VERSTELLVORRICHTG  | ADJUSTING DEVICE  | REGLAGE            | DISPOS-GRADUAC.    |                            |     |
| 77      | 121 2742 | 3          | RINGSTUECK         | BANJO FITTING     | PIECE ANNULAIRE    | PZA-ANULAR         | 3 450 A                    |     |
| 78      | 111 9246 | 3          | HOHLSCHRAUBE       | BANJO BOLT        | VIS BANJO          | TORNILLO RACOR     | A 8 DIN 7623 VZKC          |     |
| 79      | 111 8688 | 6          | DICHTRING          | WASHER            | BAGUE D ETANCHEITE | ANILLO DE JUNTA    | A 14 X 18 DIN 7603-CU      |     |
| 80      | 116 8145 | 2          | ROHRSCHELLE        | PIPE CLIP         | COLLIER PR TUBES   | ABRAZADERA DE TUBO | 815 H 3201                 |     |
| 81      | 112 8263 | 6          | SCHLAUCHSCHELLE    | HOSE CLIP         | COLLIER SERRAGE    | ABRAZADERA MANGUER | LA 10- 16DIN 3017-W1       |     |
| 83      | 232 5877 | 2          | ZUGFEDER           | DRAW SPRING       | RESSORT TRACTION   | RESORTE TRACCION   |                            | 01  |
| 84      | 233 3280 | 1          | ROHRLEITUNG        | PIPE/LINE         | TUYAUTERIE         | TUBERIA            |                            |     |
| 91      | 231 9833 | 1          | LUFTPRESSER        | AIR COMPRESSOR    | COMPRESSEUR D AIR  | COMPRESOR AIRE     |                            |     |
| 93      | 231 9838 | 1          | RUECKSCHLAGVENTIL  | CHECK VALVE       | SOUPAPE RETENUE    | VALV-DE RETENCION  |                            |     |
| 94      | 231 9834 | 1          | DRUCKMINDERVENTIL  | PRESSURE REDUCER  | DETENDEUR DE PRSSN | VALV-REDUCT-PRES-  |                            |     |
| 95      | 230 1131 | 3          | SCHLAUCHSTUTZEN    | HOSE NIPPLE       | RACCORD FLEXIBLE   | TUBULAD-MANGUERA   |                            |     |
| 96      | 230 1129 | 3          | VERSCHLUSSSCHRAUBE | SCREW PLUG        | BOUCHON FILETE     | TAPON ROSCADO      |                            |     |
| 97      | 233 3279 | 1          | BREMSVENTIL        | BRAKE VALVE       | SOUPAPE DE FREIN   | VALV-FRENO         |                            |     |
| 98      | 139 3288 | MTR        | SCHLAUCH           | HOSE              | FLEXIBLE           | MANGUERA           |                            | 01  |
| 99      | 231 9839 | 2          | KUPPLUNGSKOPF      | COUPLING          | TETE D ACCOUPLEM   | CABEZA ACOPL-      |                            |     |
| 100     | 126 0634 | 1          | ENTWASSER-VENTIL   | DRAIN VALVE       | SOUP PURGE D EAU   | VALV-DESAGUE       |                            |     |
| 101     | 340 0935 | 1          | SCHLAUCHSTUTZEN    | HOSE NIPPLE       | RACCORD FLEXIBLE   | TUBULAD-MANGUERA   | 1943-55-22-01              |     |
| 102     | 232 1213 | 1          | GUMMSCHLAUCH       | RUBBER HOSE       | FLEXIBLE CAOUTCH   | MANGUERA CAUCHO    | 1943-55-22-02              |     |
| 103     | 110 7121 | 1          | SCHLEIBE           | DISC/PANE/PLATE   | RONDELLE/DISQUE    | DISCO              | A19 DIN 125-ST-A4C         |     |

| Bld<br>Nr. | Teile-Nr. | Stück-<br>Zahl | Deutsch           | English           | Français           | Español            | Nummer/Bemerkung         | ETK |
|------------|-----------|----------------|-------------------|-------------------|--------------------|--------------------|--------------------------|-----|
| 104        | 111 3183  | 1              | SECHSKANTMUTTER   | HEX-NUT           | ECROU 6 PANS       | TUERCA HEXAGONAL   | M10X1,5 DIN 934-N55 VZKC |     |
| 106        | 210 3307  | 1              | BRUCKLEITUNG      | DELIVERY LINE     | CONDUITE DE REFOUL | TUBERIA PRESSION   | D150-33-405-30           |     |
| 107        | 111 8673  | 2              | DICHTRING         | WASHER            | BAGUE D ETANCHEITE | ANILLO DE JUNTA    | A 12 X 15,5DIN 7603-CU   |     |
| 108        | 111 9238  | 1              | WOMLSCHRAUBE      | BANJO BOLT        | VIS BANJO          | TORNILLO RACOR     | A 6 DIN 7623             |     |
| 109        | 111 8659  | 2              | DICHTRING         | WASHER            | BAGUE D ETANCHEITE | ANILLO DE JUNTA    | A 10 X 13,5DIN 7603-CU   |     |
| 110        | 111 9235  | 1              | WOMLSCHRAUBE      | BANJO BOLT        | VIS BANJO          | TORNILLO RACOR     | A 4 DIN 7623             |     |
| 111        | 231 9905  | 1              | BRENSPEDAL        | BRAKE PEDAL       | PEDALE DE FREIN    | PEDAL FRENO        | 8195-LINKS               |     |
| 112        | 231 9907  | 1              | BRENSPEDAL        | BRAKE PEDAL       | PEDALE DE FREIN    | PEDAL FRENO        | 8267-RECHTS              |     |
| 114        | 111 2412  | 2              | SECHSKANTSCHRAUBE | HEX-BOLT          | VIS 6 PANS         | TORNILLO HEXAGONAL | M10X 22 DIN 933- 8-8-A4C |     |
| 115        | 110 2800  | 4              | FEDERRING         | SPRING LOCKWASHER | RONDELLE GROMER    | ARANDELA ELASTICA  | A 10 DIN 128 A4C         |     |
| 116        | 232 9260  | 1              | SPANNSCHRAUBE     | CLAMPING BOLT     | VIS DE TENSION     | TORNILLO FIJAC-    |                          |     |
| 117        | 232 9262  | 1              | WINKEL            | ANGLE PLATE       | EGUERRE            | ANGULO             |                          |     |
| 118        | 110 2659  | 4              | SECHSKANTMUTTER   | HEX-NUT           | ECROU 6 PANS       | TUERCA HEXAGONAL   | M10 DIN 934-N 8 A4C      |     |
| 119        | 111 2228  | 1              | SECHSKANTSCHRAUBE | HEX-BOLT          | VIS 6 PANS         | TORNILLO HEXAGONAL | M 6X 8 DIN 933- 8-8-A4C  |     |
| 120        | 110 2797  | 1              | FEDERRING         | SPRING LOCKWASHER | RONDELLE GROMER    | ARANDELA ELASTICA  | A 6 DIN 128 A4C          |     |
| 121        | 233 9016  | 1              | BRENSVENTIL       | BRAKE VALVE       | SOUPAPE DE FREIN   | VALV-FRENO         |                          |     |
| 122        | 232 9174  | 1              | BETAETIGUNG       | CONTROL ASSEMBLY  | CDE D ACTIONNEM-   | ACCIONAMIENTO      |                          |     |

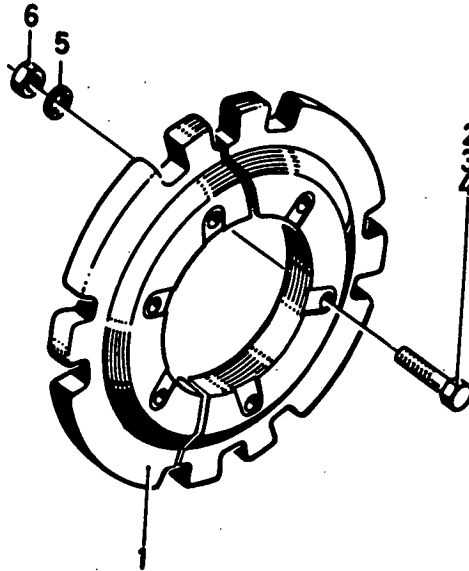

1925-61 500 4258

| Bld Nr. | Teil-Nr. | Stück-Zahl | Deutsch           | English        | Français          | Español            | Nummer/Bemerkung  | ETK |
|---------|----------|------------|-------------------|----------------|-------------------|--------------------|---|-----|
| 1       | 340 0301 | 1          | BALLASTGEWICHT    | BALLAST WEIGHT | CONTREPOIDS/LEST  | PESO DE LASTRE     | 1925-61-02-07<br>8337 VOLLSTAENDIG 40KG.<br>8285 SIEHE POS. 750-752 |     |
| 2       | 111 1670 | 6          | SECHSKANTSCHRAUBE | HEX-BOLT       | VIS 6-PANS        | TORNILLO HEXAGONAL | M16X 60 DIN 931-M 8-8 A4C   |     |
| 3       | 111 1930 | 6          | SECHSKANTSCHRAUBE | HEX-BOLT       | VIS 6-PANS        | TORNILLO HEXAGONAL | M16X 100 DIN 931-M 8-8 A4C  |     |
| 4       | 111 1949 | 6          | SECHSKANTSCHRAUBE | HEX-BOLT       | VIS 6 PANS        | TORNILLO HEXAGONAL | M16X 140 DIN 931-M 8-8 A4C  |     |
| 5       | 111 9697 | 6          | SICHERUNGSSCHEIBE | LOCKING WASHER | RONDELLE SECURITE | ARANDELA SEGURIDAD | 16 H 2203   |     |
| 6       | 111 8886 | 6          | SECHSKANTHUTTER   | HEX-NUT        | ECROU 6 PANS      | TUERCA HEXAGONAL   | M16 DIN 934-M 8 A4C   |     |
| 750     | 340 0302 | 2          | BALLASTGEWICHT    | BALLAST WEIGHT | CONTREPOIDS/LEST  | PESO DE LASTRE     | 1925-61-02-10<br>8347 VOLLSTAENDIG MIT POS.<br>1-2-5-6 80KG.        |     |
| 751     | 340 0303 | 4          | BALLASTGEWICHT    | BALLAST WEIGHT | CONTREPOIDS/LEST  | PESO DE LASTRE     | 1925-61-02-20<br>8347 VOLLSTAENDIG MIT POS.<br>1-3-5-6 160KG.       |     |
| 752     | 340 0304 | 6          | BALLASTGEWICHT    | BALLAST WEIGHT | CONTREPOIDS/LEST  | PESO DE LASTRE     | 1925-61-02-30<br>8347 VOLLSTAENDIG MIT POS.<br>1-4-6 240KG.         |     |

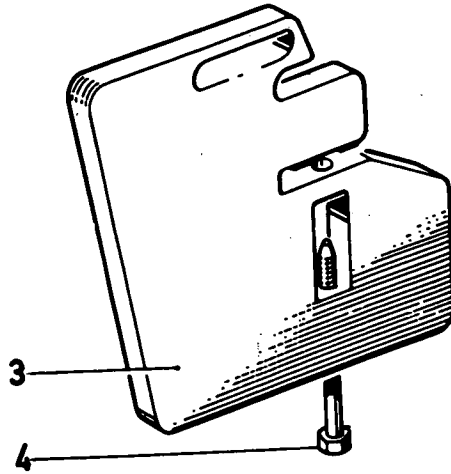

1926-62 500 5148

| Bild-Nr. | Teil-Nr. | Stück-Zahl | Deutsch            | English        | Français         | Español          | Nummer/Bemerkung | ETK |
|----------|----------|------------|--------------------|----------------|------------------|------------------|------------------|-----|
| 3        | 231 3817 | NB         | BALLASTGEWICHT     | BALLAST WEIGHT | CONTREPOIDS/LEST | PESO DE LASTRE   | 22 KG.           |     |
| 4        | 231 3813 | NB         | SKT.-SPITZSCHRAUBE | POINTED SCREW  | VIS 6 P A POINTE | TORN-HEX-C-PUNTA |                  |     |

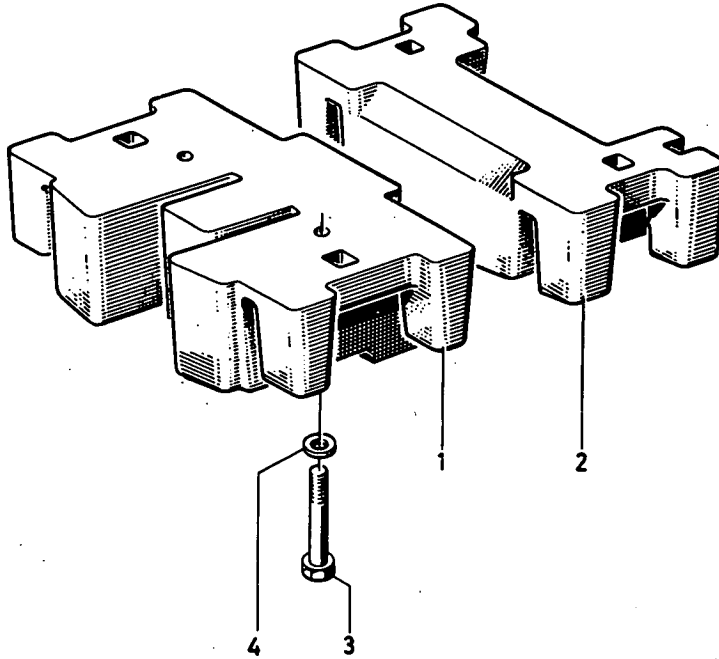

1926-62 500 5149

| Bild-Nr. | Teile-Nr. | Stück-Zahl | Deutsch           | English         | Français         | Español            | Nummer/Bemerkung          | ETK |
|----------|-----------|------------|-------------------|-----------------|------------------|--------------------|---------------------------|-----|
| 1        | 230 6304  | 1          | BALLASTGEWICHT    | BALLAST WEIGHT  | CONTREPOIDS/LEST | PESO DE LASTRE     | 50 KG.                    |     |
| 2        | 230 6306  | 1          | BALLASTGEWICHT    | BALLAST WEIGHT  | CONTREPOIDS/LEST | PESO DE LASTRE     | 32 KG.                    |     |
| 3        | 111 2687  | 2          | SECHSKANTSCHRAUBE | HEX-BOLT        | VIS 6 PANS       | TORNILLO HEXAGONAL | M16X 40 DIN 933-M 8-8 A9C |     |
| 4        | 110 7117  | 2          | SCHEIBE           | DISC/PANE/PLATE | RONDELLE/DISQUE  | DISCO              | A17 DIN 125-ST-A9C        |     |

| TEILE-NR | SEITE | BILD | TEILE-NR | SEITE | BILD | TEILE-NR | SEITE | BILD |
|----------|-------|------|----------|-------|------|----------|-------|------|
| 000 0000 | 59    | 6    | 110 2022 | 114   | 5    | 110 2797 | 77    | 2    |
| 110 0169 | 252   | 26   | 110 2046 | 55    | 2    | 110 2797 | 78    | 2    |
| 110 0507 | 132   | 27   | 110 2048 | 324   | 48   | 110 2797 | 78    | 8    |
| 110 0925 | 323   | 23   | 110 2048 | 329   | 18   | 110 2797 | 81    | 3    |
| 110 0925 | 326   | 34   | 110 2193 | 124   | 30   | 110 2797 | 82    | 2    |
| 110 0925 | 327   | 5    | 110 2193 | 125   | 15   | 110 2797 | 82    | 12   |
| 110 1007 | 167   | 3    | 110 2193 | 197   | 6    | 110 2797 | 89    | 5    |
| 110 1016 | 183   | 11   | 110 2193 | 198   | 16   | 110 2797 | 114   | 19   |
| 110 1016 | 186   | 41   | 110 2193 | 199   | 6    | 110 2797 | 115   | 22   |
| 110 1024 | 282   | 21   | 110 2193 | 200   | 16   | 110 2797 | 120   | 22   |
| 110 1024 | 284   | 8    | 110 2194 | 124   | 32   | 110 2797 | 124   | 6    |
| 110 1084 | 321   | 11   | 110 2194 | 279   | 24   | 110 2797 | 129   | 29   |
| 110 1145 | 105   | 12   | 110 2258 | 224   | 4    | 110 2797 | 132   | 24   |
| 110 1300 | 308   | 11   | 110 2295 | 40    | 3    | 110 2797 | 191   | 74   |
| 110 1323 | 153   | 151  | 110 2298 | 166   | 14   | 110 2797 | 198   | 22   |
| 110 1339 | 134   | 8    | 110 2298 | 167   | 12   | 110 2797 | 199   | 19   |
| 110 1340 | 134   | 26   | 110 2301 | 91    | 2    | 110 2797 | 200   | 21   |
| 110 1384 | 134   | 25   | 110 2335 | 292   | 190  | 110 2797 | 202   | 10   |
| 110 1386 | 134   | 7    | 110 2335 | 297   | 190  | 110 2797 | 264   | 5    |
| 110 1402 | 325   | 27   | 110 2346 | 326   | 36   | 110 2797 | 287   | 55   |
| 110 1402 | 327   | 13   | 110 2346 | 327   | 15   | 110 2797 | 331   | 59   |
| 110 1405 | 323   | 42   | 110 2347 | 323   | 21   | 110 2797 | 334   | 59   |
| 110 1405 | 329   | 12   | 110 2347 | 326   | 39   | 110 2797 | 335   | 120  |
| 110 1406 | 324   | 45   | 110 2347 | 327   | 27   | 110 2799 | 35    | 24   |
| 110 1406 | 329   | 15   | 110 2356 | 272   | 13   | 110 2799 | 37    | 6    |
| 110 1407 | 324   | 47   | 110 2372 | 302   | 15   | 110 2799 | 38    | 7    |
| 110 1407 | 329   | 17   | 110 2507 | 323   | 19   | 110 2799 | 46    | 1    |
| 110 1409 | 110   | 11   | 110 2550 | 228   | 9    | 110 2799 | 63    | 5    |
| 110 1431 | 256   | 7    | 110 2550 | 229   | 11   | 110 2799 | 79    | 3    |
| 110 1461 | 95    | 13   | 110 2659 | 55    | 15   | 110 2799 | 81    | 7    |
| 110 1492 | 47    | 1    | 110 2659 | 59    | 9    | 110 2799 | 87    | 5    |
| 110 1492 | 195   | 6    | 110 2659 | 87    | 6    | 110 2799 | 93    | 9    |
| 110 1492 | 196   | 6    | 110 2659 | 91    | 3    | 110 2799 | 95    | 17   |
| 110 1492 | 230   | 13   | 110 2659 | 97    | 2    | 110 2799 | 102   | 28   |
| 110 1492 | 231   | 13   | 110 2659 | 98    | 2    | 110 2799 | 102   | 29   |
| 110 1492 | 233   | 23   | 110 2659 | 99    | 38   | 110 2799 | 115   | 28   |
| 110 1503 | 160   | 6    | 110 2659 | 101   | 38   | 110 2799 | 117   | 8    |
| 110 1505 | 226   | 16   | 110 2659 | 139   | 45   | 110 2799 | 120   | 28   |
| 110 1505 | 229   | 10   | 110 2659 | 152   | 72   | 110 2799 | 122   | 8    |
| 110 1512 | 139   | 53   | 110 2659 | 157   | 7    | 110 2799 | 128   | 26   |
| 110 1597 | 138   | 14   | 110 2659 | 181   | 16   | 110 2799 | 139   | 49   |
| 110 1603 | 224   | 9    | 110 2659 | 186   | 6    | 110 2799 | 152   | 82   |
| 110 1765 | 204   | 13   | 110 2659 | 187   | 96   | 110 2799 | 182   | 55   |
| 110 1765 | 205   | 14   | 110 2659 | 195   | 5    | 110 2799 | 196   | 12   |
| 110 1765 | 206   | 14   | 110 2659 | 223   | 14   | 110 2799 | 198   | 21   |
| 110 1909 | 151   | 20   | 110 2659 | 231   | 64   | 110 2799 | 199   | 8    |
| 110 1922 | 166   | 8    | 110 2659 | 253   | 4    | 110 2799 | 200   | 20   |
| 110 1923 | 167   | 9    | 110 2659 | 281   | 26   | 110 2799 | 202   | 14   |
| 110 1932 | 230   | 22   | 110 2659 | 286   | 24   | 110 2799 | 205   | 7    |
| 110 1932 | 231   | 22   | 110 2659 | 302   | 8    | 110 2799 | 206   | 6    |
| 110 1932 | 233   | 7    | 110 2659 | 332   | 118  | 110 2799 | 208   | 19   |
| 110 1940 | 226   | 9    | 110 2659 | 335   | 118  | 110 2799 | 270   | 17   |
| 110 1940 | 228   | 6    | 110 2756 | 242   | 51   | 110 2799 | 272   | 11   |
| 110 1947 | 227   | 22   | 110 2756 | 243   | 13   | 110 2799 | 279   | 17   |
| 110 1948 | 182   | 40   | 110 2756 | 245   | 8    | 110 2799 | 330   | 7    |
| 110 1957 | 247   | 18   | 110 2795 | 331   | 32   | 110 2799 | 333   | 7    |
| 110 2013 | 114   | 24   | 110 2795 | 334   | 32   | 110 2800 | 38    | 5    |
| 110 2014 | 114   | 22   | 110 2796 | 214   | 74   | 110 2800 | 59    | 12   |
| 110 2016 | 114   | 4    | 110 2796 | 216   | 74   | 110 2800 | 91    | 1    |
| 110 2017 | 114   | 6    | 110 2796 | 316   | 11   | 110 2800 | 139   | 46   |
| 110 2018 | 114   | 14   | 110 2797 | 493   | 73   | 110 2800 | 157   | 6    |
| 110 2020 | 207   | 2    | 110 2797 | 70    | 9    | 110 2800 | 160   | 8    |

| TEILE-NR | SEITE | BILD | TEILE-NR | SEITE | BILD | TEILE-NR | SEITE | BILD |
|----------|-------|------|----------|-------|------|----------|-------|------|
| 11C 2800 | 181   | 17   | 110 4653 | 286   | 15   | 110 6468 | 305   | 3    |
| 11C 2800 | 186   | 9    | 110 4674 | 317   | 12   | 110 6468 | 309   | 3    |
| 11C 2800 | 187   | 95   | 110 4687 | 160   | 34   | 110 6468 | 310   | 3    |
| 11C 2800 | 195   | 12   | 110 4845 | 51    | 2    | 110 6468 | 317   | 14   |
| 11C 2800 | 279   | 14   | 110 4845 | 65    | 2    | 110 6472 | 169   | 24   |
| 11C 2800 | 281   | 25   | 110 4895 | 161   | 45   | 110 6472 | 171   | 24   |
| 11C 2800 | 286   | 23   | 110 4895 | 162   | 45   | 110 6472 | 173   | 28   |
| 11C 2800 | 302   | 18   | 110 4895 | 163   | 20   | 110 6482 | 207   | 22   |
| 11C 2800 | 330   | 8    | 110 4895 | 165   | 37   | 110 6482 | 208   | 25   |
| 11C 2800 | 335   | 115  | 110 4896 | 315   | 38   | 110 6484 | 318   | 14   |
| 11C 2801 | 67    | 5    | 110 5127 | 115   | 24   | 110 6496 | 156   | 9    |
| 11C 2801 | 114   | 21   | 110 5127 | 120   | 24   | 110 6499 | 303   | 22   |
| 11C 2801 | 292   | 158  | 110 5155 | 114   | 15   | 110 6499 | 305   | 22   |
| 11C 2801 | 331   | 38   | 110 5166 | 49    | 3    | 110 6511 | 321   | 7    |
| 11C 2802 | 166   | 17   | 110 5213 | 114   | 2    | 110 7089 | 189   | 4    |
| 11C 2802 | 167   | 18   | 110 5213 | 126   | 32   | 110 7089 | 210   | 4    |
| 11C 2802 | 231   | 32   | 110 5512 | 331   | 30   | 110 7089 | 247   | 14   |
| 11C 2802 | 279   | 13   | 110 5512 | 334   | 30   | 110 7095 | 78    | 7    |
| 11C 2802 | 286   | 27   | 110 5526 | 213   | 17   | 110 7095 | 82    | 8    |
| 11C 2802 | 313   | 38   | 110 5526 | 215   | 16   | 110 7095 | 142   | 16   |
| 11C 2802 | 314   | 7    | 110 5526 | 215   | 17   | 110 7095 | 143   | 16   |
| 11C 2802 | 321   | 18   | 110 5526 | 223   | 25   | 110 7095 | 200   | 22   |
| 11C 2802 | 331   | 46   | 110 5537 | 199   | 17   | 110 7095 | 202   | 11   |
| 11C 2803 | 258   | 4    | 110 5537 | 200   | 15   | 110 7095 | 207   | 32   |
| 11C 2803 | 259   | 4    | 110 5537 | 202   | 8    | 110 7095 | 208   | 22   |
| 11C 2803 | 281   | 31   | 110 5593 | 189   | 7    | 110 7095 | 280   | 58   |
| 11C 2803 | 303   | 13   | 110 5669 | 225   | 33   | 110 7095 | 301   | 16   |
| 11C 2803 | 317   | 9    | 110 6256 | 220   | 23   | 110 7098 | 156   | 8    |
| 11C 2803 | 321   | 31   | 110 6256 | 221   | 23   | 110 7098 | 291   | 82   |
| 11C 2804 | 313   | 16   | 110 6354 | 152   | 68   | 110 7098 | 296   | 82   |
| 11C 2805 | 318   | 9    | 110 6354 | 153   | 124  | 110 7101 | 38    | 2    |
| 11C 2848 | 168   | 2    | 110 6398 | 293   | 307  | 110 7101 | 40    | 4    |
| 11C 3177 | 214   | 58   | 110 6398 | 298   | 302  | 110 7101 | 57    | 3    |
| 11C 3177 | 216   | 58   | 110 6403 | 127   | 52   | 110 7101 | 74    | 4    |
| 11C 3252 | 231   | 36   | 110 6404 | 142   | 17   | 110 7101 | 75    | 5    |
| 11C 3316 | 160   | 44   | 110 6404 | 143   | 17   | 110 7101 | 76    | 13   |
| 11C 3335 | 157   | 10   | 110 6404 | 210   | 5    | 110 7101 | 78    | 12   |
| 11C 3389 | 211   | 26   | 110 6407 | 125   | 20   | 110 7101 | 79    | 2    |
| 11C 3420 | 231   | 63   | 110 6407 | 207   | 7    | 110 7101 | 81    | 6    |
| 11C 3420 | 233   | 24   | 110 6407 | 208   | 23   | 110 7101 | 82    | 6    |
| 11C 3519 | 213   | 16   | 110 6407 | 291   | 119  | 110 7101 | 196   | 4    |
| 11C 3598 | 179   | 9    | 110 6407 | 296   | 119  | 110 7101 | 207   | 6    |
| 11C 3599 | 177   | 26   | 110 6408 | 125   | 2    | 110 7101 | 208   | 21   |
| 11C 3990 | 232   | 66   | 110 6427 | 94    | 34   | 110 7101 | 212   | 57   |
| 11C 3990 | 234   | 27   | 110 6427 | 96    | 45   | 110 7101 | 235   | 13   |
| 11C 3999 | 316   | 10   | 110 6431 | 241   | 40   | 110 7101 | 240   | 5    |
| 11C 4150 | 213   | 26   | 110 6434 | 154   | 184  | 110 7101 | 247   | 22   |
| 11C 4150 | 215   | 26   | 110 6435 | 292   | 186  | 110 7101 | 301   | 5    |
| 11C 4151 | 153   | 122  | 110 6435 | 297   | 186  | 110 7101 | 331   | 72   |
| 11C 4188 | 241   | 38   | 110 6437 | 183   | 32   | 110 7101 | 334   | 72   |
| 11C 4188 | 243   | 7    | 110 6437 | 187   | 62   | 110 7105 | 61    | 3    |
| 11C 4188 | 245   | 7    | 110 6446 | 156   | 4    | 110 7105 | 87    | 7    |
| 11C 4273 | 111   | 62   | 110 6447 | 99    | 23   | 110 7105 | 195   | 4    |
| 11C 4273 | 114   | 35   | 110 6447 | 101   | 23   | 110 7105 | 237   | 7    |
| 11C 4310 | 316   | 5    | 110 6447 | 142   | 20   | 110 7105 | 238   | 9    |
| 11C 4333 | 220   | 12   | 110 6447 | 143   | 20   | 110 7105 | 239   | 9    |
| 11C 4567 | 317   | 13   | 110 6447 | 208   | 24   | 110 7105 | 242   | 52   |
| 11C 4567 | 318   | 13   | 110 6447 | 321   | 14   | 110 7105 | 243   | 9    |
| 11C 4567 | 319   | 4    | 110 6449 | 233   | 12   | 110 7105 | 245   | 9    |
| 11C 4567 | 320   | 4    | 110 6451 | 207   | 15   | 110 7105 | 291   | 102  |
| 11C 4568 | 208   | 13   | 110 6467 | 175   | 27   | 110 7105 | 296   | 102  |
| 11C 4633 | 258   | 28   | 110 6468 | 303   | 3    | 110 7110 | 165   | 34   |



| TEILE-NR | SEITE | BILD | TEILE-NR | SEITE | BILD | TEILE-NR | SEITE | BILD |
|----------|-------|------|----------|-------|------|----------|-------|------|
| 110 7110 | 208   | 20   | 110 7554 | 162   | 25   | 110 8137 | 290   | 19   |
| 110 7110 | 214   | 76   | 110 7554 | 163   | 13   | 110 8137 | 295   | 19   |
| 110 7110 | 216   | 76   | 110 7554 | 164   | 13   | 110 8178 | 296   | 95   |
| 110 7110 | 230   | 18   | 110 7557 | 129   | 32   | 110 8330 | 238   | 10   |
| 110 7110 | 231   | 18   | 110 7557 | 291   | 79   | 110 8330 | 239   | 10   |
| 110 7110 | 243   | 17   | 110 7557 | 296   | 79   | 110 8785 | 138   | 3    |
| 110 7110 | 245   | 10   | 110 7721 | 119   | 64   | 110 8981 | 128   | 3    |
| 110 7110 | 292   | 205  | 110 7730 | 114   | 3    | 110 8981 | 151   | 28   |
| 110 7110 | 297   | 205  | 110 7730 | 155   | 19   | 110 9001 | 136   | 12   |
| 110 7110 | 321   | 12   | 110 7732 | 311   | 32   | 110 9041 | 76    | 3    |
| 110 7114 | 207   | 20   | 110 7732 | 312   | 32   | 110 9050 | 270   | 7    |
| 110 7114 | 286   | 26   | 110 7737 | 99    | 8    | 110 9057 | 126   | 8    |
| 110 7114 | 321   | 10   | 110 7737 | 101   | 8    | 110 9057 | 272   | 8    |
| 110 7117 | 245   | 25   | 110 7737 | 272   | 20   | 110 9059 | 270   | 31   |
| 110 7117 | 303   | 27   | 110 7739 | 158   | 28   | 110 9059 | 272   | 18   |
| 110 7117 | 305   | 27   | 110 7740 | 161   | 24   | 110 9062 | 138   | 15   |
| 110 7117 | 317   | 11   | 110 7740 | 162   | 24   | 110 9072 | 128   | 5    |
| 110 7117 | 338   | 4    | 110 7740 | 163   | 17   | 110 9074 | 144   | 6    |
| 110 7121 | 309   | 4    | 110 7740 | 164   | 17   | 110 9074 | 145   | 6    |
| 110 7121 | 310   | 4    | 110 7742 | 111   | 88   | 110 9090 | 146   | 11   |
| 110 7121 | 334   | 103  | 110 7742 | 270   | 6    | 110 9090 | 147   | 11   |
| 110 7124 | 318   | 11   | 110 7747 | 114   | 7    | 110 9121 | 128   | 16   |
| 110 7127 | 303   | 21   | 110 7748 | 128   | 14   | 110 9129 | 128   | 13   |
| 110 7127 | 305   | 21   | 110 7748 | 270   | 44   | 110 9888 | 185   | 50   |
| 110 7162 | 127   | 53   | 110 7749 | 110   | 29   | 110 9955 | 169   | 22   |
| 110 7163 | 99    | 65   | 110 7751 | 160   | 14   | 110 9955 | 171   | 22   |
| 110 7163 | 101   | 65   | 110 7755 | 107   | 61   | 110 9955 | 173   | 26   |
| 110 7237 | 297   | 108  | 110 7755 | 110   | 6    | 110 9955 | 175   | 25   |
| 110 7240 | 233   | 9    | 110 7760 | 152   | 36   | 110 9957 | 169   | 21   |
| 110 7240 | 256   | 5    | 110 7782 | 139   | 37   | 110 9957 | 171   | 21   |
| 110 7242 | 305   | 13   | 110 7808 | 107   | 63   | 110 9957 | 173   | 25   |
| 110 7270 | 118   | 113  | 110 7808 | 111   | 78   | 110 9957 | 175   | 24   |
| 110 7279 | 123   | 113  | 110 7821 | 53    | 3    | 110 9963 | 152   | 54   |
| 110 7279 | 292   | 243  | 110 7827 | 185   | 44   | 110 9964 | 152   | 55   |
| 110 7279 | 297   | 243  | 110 7834 | 76    | 5    | 110 9965 | 138   | 11   |
| 110 7281 | 67    | 7    | 110 7838 | 272   | 4    | 110 9981 | 151   | 21   |
| 110 7283 | 78    | 5    | 110 7841 | 185   | 92   | 110 9990 | 108   | 99   |
| 110 7283 | 82    | 5    | 110 7844 | 128   | 15   | 110 9990 | 111   | 70   |
| 110 7289 | 158   | 26   | 110 7846 | 107   | 4    | 111 0005 | 151   | 7    |
| 110 7289 | 231   | 27   | 110 7846 | 153   | 105  | 111 0187 | 205   | 8    |
| 110 7289 | 233   | 13   | 110 7855 | 139   | 34   | 111 0187 | 206   | 5    |
| 110 7356 | 264   | 4    | 110 7859 | 139   | 25   | 111 0190 | 74    | 2    |
| 110 7359 | 211   | 8    | 110 7862 | 138   | 22   | 111 0190 | 83    | 2    |
| 110 7359 | 242   | 48   | 110 7863 | 134   | 9    | 111 0190 | 84    | 2    |
| 110 7359 | 243   | 20   | 110 7866 | 148   | 10   | 111 0254 | 55    | 3    |
| 110 7359 | 245   | 18   | 110 7866 | 149   | 10   | 111 0415 | 282   | 32   |
| 110 7434 | 282   | 36   | 110 7955 | 292   | 252  | 111 0415 | 284   | 17   |
| 110 7434 | 284   | 14   | 110 7955 | 297   | 252  | 111 0422 | 75    | 2    |
| 110 7548 | 125   | 19   | 110 7969 | 292   | 262  | 111 0422 | 185   | 74   |
| 110 7548 | 290   | 9    | 110 7969 | 297   | 270  | 111 0507 | 130   | 2    |
| 110 7548 | 295   | 9    | 110 8012 | 282   | 5    | 111 0517 | 275   | 9    |
| 110 7549 | 125   | 1    | 110 8012 | 284   | 3    | 111 0517 | 277   | 9    |
| 110 7549 | 137   | 17   | 110 8064 | 99    | 63   | 111 0543 | 299   | 42   |
| 110 7553 | 156   | 3    | 110 8064 | 101   | 63   | 111 0543 | 300   | 42   |
| 110 7553 | 282   | 25   | 110 8064 | 247   | 10   | 111 0550 | 291   | 66   |
| 110 7554 | 97    | 9    | 110 8065 | 225   | 40   | 111 0550 | 296   | 66   |
| 110 7554 | 98    | 9    | 110 8066 | 246   | 28   | 111 0560 | 107   | 6    |
| 110 7554 | 99    | 24   | 110 8066 | 317   | 15   | 111 0560 | 117   | 34   |
| 110 7554 | 101   | 24   | 110 8066 | 318   | 16   | 111 0560 | 122   | 34   |
| 110 7554 | 142   | 25   | 110 8066 | 319   | 5    | 111 0561 | 277   | 36   |
| 110 7554 | 143   | 25   | 110 8066 | 320   | 5    | 111 0577 | 185   | 65   |
| 110 7554 | 161   | 25   | 110 8132 | 137   | 12   | 111 0622 | 323   | 44   |

| TEILE-NR | SEITE | BILD | TEILE-NR | SEITE | BILD | TEILE-NR | SEITE | BILD |
|----------|-------|------|----------|-------|------|----------|-------|------|
| 111 0622 | 329   | 14   | 111 1528 | 126   | 19   | 111 2299 | 63    | 4    |
| 111 0634 | 200   | 39   | 111 1589 | 76    | 6    | 111 2299 | 78    | 4    |
| 111 0634 | 295   | 39   | 111 1596 | 138   | 12   | 111 2299 | 79    | 4    |
| 111 0665 | 107   | 53   | 111 1693 | 314   | 8    | 111 2299 | 82    | 4    |
| 111 0665 | 110   | 55   | 111 1709 | 183   | 6    | 111 2299 | 134   | 15   |
| 111 0682 | 275   | 3    | 111 1709 | 186   | 40   | 111 2299 | 188   | 6    |
| 111 0682 | 277   | 3    | 111 1759 | 321   | 21   | 111 2299 | 189   | 13   |
| 111 0688 | 36    | 1    | 111 1762 | 126   | 37   | 111 2299 | 230   | 17   |
| 111 0712 | 105   | 7    | 111 1778 | 126   | 36   | 111 2299 | 231   | 17   |
| 111 0734 | 105   | 8    | 111 1780 | 299   | 3    | 111 2299 | 233   | 20   |
| 111 0752 | 114   | 1    | 111 1861 | 317   | 10   | 111 2299 | 241   | 4    |
| 111 0756 | 102   | 12   | 111 1870 | 336   | 2    | 111 2299 | 247   | 9    |
| 111 0763 | 235   | 5    | 111 1888 | 130   | 7    | 111 2299 | 274   | 16   |
| 111 0764 | 291   | 115  | 111 1930 | 336   | 3    | 111 2299 | 290   | 7    |
| 111 0764 | 296   | 115  | 111 1949 | 336   | 4    | 111 2299 | 295   | 7    |
| 111 0782 | 291   | 113  | 111 1960 | 129   | 31   | 111 2305 | 81    | 5    |
| 111 0782 | 296   | 113  | 111 2057 | 318   | 10   | 111 2305 | 99    | 61   |
| 111 0805 | 102   | 11   | 111 2201 | 198   | 15   | 111 2305 | 101   | 61   |
| 111 0855 | 160   | 35   | 111 2215 | 331   | 62   | 111 2305 | 102   | 16   |
| 111 1060 | 154   | 181  | 111 2215 | 334   | 62   | 111 2305 | 117   | 15   |
| 111 1071 | 311   | 15   | 111 2228 | 335   | 119  | 111 2305 | 122   | 15   |
| 111 1071 | 312   | 15   | 111 2232 | 81    | 2    | 111 2305 | 189   | 19   |
| 111 1124 | 153   | 100  | 111 2232 | 105   | 20   | 111 2305 | 201   | 6    |
| 111 1132 | 57    | 1    | 111 2232 | 287   | 54   | 111 2305 | 212   | 56   |
| 111 1136 | 196   | 3    | 111 2238 | 115   | 23   | 111 2305 | 230   | 15   |
| 111 1142 | 115   | 29   | 111 2238 | 120   | 23   | 111 2305 | 231   | 15   |
| 111 1142 | 120   | 29   | 111 2240 | 70    | 7    | 111 2305 | 233   | 21   |
| 111 1145 | 117   | 9    | 111 2240 | 78    | 1    | 111 2305 | 240   | 4    |
| 111 1145 | 122   | 9    | 111 2240 | 78    | 6    | 111 2305 | 241   | 10   |
| 111 1145 | 182   | 54   | 111 2240 | 82    | 1    | 111 2305 | 247   | 12   |
| 111 1145 | 279   | 18   | 111 2240 | 82    | 11   | 111 2305 | 259   | 5    |
| 111 1151 | 47    | 7    | 111 2240 | 89    | 3    | 111 2305 | 271   | 50   |
| 111 1153 | 287   | 56   | 111 2240 | 114   | 20   | 111 2305 | 291   | 56   |
| 111 1166 | 38    | 1    | 111 2240 | 132   | 23   | 111 2305 | 296   | 56   |
| 111 1168 | 60    | 2    | 111 2240 | 331   | 40   | 111 2305 | 331   | 71   |
| 111 1168 | 194   | 14   | 111 2240 | 334   | 40   | 111 2305 | 334   | 71   |
| 111 1170 | 38    | 3    | 111 2248 | 63    | 6    | 111 2311 | 155   | 4    |
| 111 1179 | 75    | 4    | 111 2251 | 193   | 71   | 111 2311 | 240   | 7    |
| 111 1179 | 331   | 44   | 111 2251 | 77    | 3    | 111 2311 | 241   | 9    |
| 111 1195 | 38    | 6    | 111 2251 | 131   | 37   | 111 2311 | 302   | 20   |
| 111 1195 | 93    | 12   | 111 2251 | 188   | 9    | 111 2314 | 132   | 4    |
| 111 1200 | 87    | 12   | 111 2251 | 189   | 16   | 111 2320 | 124   | 7    |
| 111 1200 | 330   | 3    | 111 2251 | 191   | 72   | 111 2320 | 137   | 9    |
| 111 1200 | 333   | 3    | 111 2251 | 207   | 4    | 111 2320 | 270   | 18   |
| 111 1210 | 76    | 10   | 111 2251 | 208   | 12   | 111 2320 | 272   | 25   |
| 111 1212 | 46    | 6    | 111 2251 | 261   | 3    | 111 2322 | 35    | 23   |
| 111 1212 | 47    | 8    | 111 2251 | 274   | 11   | 111 2322 | 125   | 8    |
| 111 1288 | 223   | 13   | 111 2251 | 280   | 52   | 111 2322 | 139   | 48   |
| 111 1298 | 181   | 15   | 111 2255 | 115   | 27   | 111 2322 | 201   | 5    |
| 111 1298 | 186   | 15   | 111 2255 | 117   | 7    | 111 2322 | 202   | 15   |
| 111 1298 | 187   | 94   | 111 2255 | 120   | 27   | 111 2322 | 205   | 13   |
| 111 1308 | 157   | 5    | 111 2258 | 128   | 28   | 111 2322 | 206   | 13   |
| 111 1315 | 153   | 99   | 111 2258 | 198   | 18   | 111 2322 | 208   | 11   |
| 111 1325 | 153   | 98   | 111 2258 | 211   | 33   | 111 2322 | 212   | 84   |
| 111 1334 | 38    | 4    | 111 2258 | 290   | 3    | 111 2322 | 224   | 5    |
| 111 1336 | 281   | 23   | 111 2264 | 117   | 37   | 111 2322 | 235   | 11   |
| 111 1336 | 286   | 22   | 111 2264 | 122   | 37   | 111 2322 | 331   | 36   |
| 111 1339 | 236   | 5    | 111 2264 | 204   | 19   | 111 2326 | 99    | 62   |
| 111 1339 | 237   | 3    | 111 2264 | 205   | 16   | 111 2326 | 101   | 62   |
| 111 1345 | 87    | 14   | 111 2264 | 206   | 16   | 111 2326 | 134   | 13   |
| 111 1385 | 61    | 2    | 111 2295 | 37    | 5    | 111 2326 | 155   | 9    |
| 111 1499 | 136   | 6    | 111 2295 | 153   | 163  | 111 2326 | 160   | 31   |

| TEILE-NR | SEITE | BILD | TEILE-NR | SEITE | BILD | TEILE-NR | SEITE | BILD |
|----------|-------|------|----------|-------|------|----------|-------|------|
| 111 2326 | 241   | 11   | 111 2631 | 144   | 9    | 111 2813 | 297   | 244  |
| 111 2331 | 93    | 14   | 111 2631 | 146   | 5    | 111 2813 | 331   | 41   |
| 111 2331 | 272   | 12   | 111 2631 | 148   | 23   | 111 2813 | 334   | 41   |
| 111 2333 | 46    | 2    | 111 2631 | 166   | 6    | 111 2824 | 40    | 5    |
| 111 2333 | 87    | 11   | 111 2631 | 167   | 13   | 111 2824 | 55    | 13   |
| 111 2333 | 128   | 25   | 111 2631 | 314   | 5    | 111 2824 | 74    | 3    |
| 111 2333 | 179   | 38   | 111 2636 | 148   | 24   | 111 2824 | 76    | 12   |
| 111 2333 | 204   | 6    | 111 2636 | 331   | 45   | 111 2824 | 124   | 19   |
| 111 2333 | 237   | 8    | 111 2663 | 259   | 3    | 111 2824 | 160   | 32   |
| 111 2333 | 279   | 21   | 111 2679 | 258   | 3    | 111 2824 | 182   | 56   |
| 111 2333 | 330   | 2    | 111 2679 | 281   | 29   | 111 2824 | 188   | 14   |
| 111 2333 | 333   | 2    | 111 2679 | 313   | 37   | 111 2824 | 189   | 20   |
| 111 2339 | 47    | 2    | 111 2679 | 314   | 11   | 111 2824 | 196   | 5    |
| 111 2341 | 95    | 16   | 111 2679 | 322   | 40   | 111 2824 | 197   | 9    |
| 111 2341 | 188   | 13   | 111 2687 | 145   | 19   | 111 2824 | 198   | 20   |
| 111 2341 | 196   | 10   | 111 2687 | 147   | 16   | 111 2824 | 199   | 9    |
| 111 2350 | 195   | 3    | 111 2687 | 149   | 46   | 111 2824 | 200   | 19   |
| 111 2350 | 331   | 70   | 111 2687 | 338   | 3    | 111 2824 | 201   | 7    |
| 111 2350 | 334   | 70   | 111 2693 | 145   | 20   | 111 2824 | 204   | 7    |
| 111 2391 | 275   | 56   | 111 2693 | 147   | 17   | 111 2824 | 205   | 15   |
| 111 2397 | 156   | 13   | 111 2693 | 149   | 59   | 111 2824 | 206   | 15   |
| 111 2407 | 279   | 19   | 111 2693 | 281   | 30   | 111 2824 | 208   | 14   |
| 111 2407 | 331   | 60   | 111 2693 | 303   | 16   | 111 2824 | 212   | 83   |
| 111 2412 | 99    | 66   | 111 2693 | 305   | 16   | 111 2824 | 224   | 6    |
| 111 2412 | 101   | 66   | 111 2693 | 313   | 12   | 111 2824 | 230   | 16   |
| 111 2412 | 235   | 4    | 111 2697 | 321   | 22   | 111 2824 | 231   | 16   |
| 111 2412 | 335   | 114  | 111 2701 | 149   | 47   | 111 2824 | 233   | 22   |
| 111 2418 | 142   | 15   | 111 2796 | 212   | 50   | 111 2824 | 240   | 3    |
| 111 2418 | 143   | 15   | 111 2796 | 224   | 11   | 111 2824 | 241   | 6    |
| 111 2423 | 253   | 5    | 111 2796 | 247   | 13   | 111 2824 | 259   | 6    |
| 111 2427 | 137   | 5    | 111 2796 | 331   | 31   | 111 2824 | 279   | 16   |
| 111 2429 | 195   | 10   | 111 2796 | 334   | 31   | 111 2824 | 290   | 17   |
| 111 2429 | 242   | 54   | 111 2803 | 189   | 3    | 111 2824 | 295   | 17   |
| 111 2429 | 243   | 18   | 111 2803 | 212   | 41   | 111 2824 | 302   | 21   |
| 111 2429 | 245   | 4    | 111 2803 | 213   | 18   | 111 2824 | 330   | 5    |
| 111 2429 | 299   | 4    | 111 2803 | 215   | 18   | 111 2824 | 333   | 5    |
| 111 2439 | 160   | 9    | 111 2803 | 247   | 30   | 111 2831 | 208   | 15   |
| 111 2439 | 302   | 9    | 111 2813 | 193   | 72   | 111 2841 | 105   | 16   |
| 111 2451 | 102   | 7    | 111 2813 | 59    | 18   | 111 2842 | 233   | 25   |
| 111 2461 | 102   | 8    | 111 2813 | 63    | 8    | 111 2852 | 291   | 122  |
| 111 2466 | 99    | 67   | 111 2813 | 70    | 8    | 111 2852 | 296   | 122  |
| 111 2466 | 101   | 67   | 111 2813 | 78    | 9    | 111 2858 | 76    | 9    |
| 111 2470 | 97    | 17   | 111 2813 | 82    | 7    | 111 2858 | 98    | 6    |
| 111 2470 | 98    | 17   | 111 2813 | 89    | 4    | 111 2858 | 149   | 48   |
| 111 2476 | 105   | 15   | 111 2813 | 188   | 10   | 111 2858 | 156   | 17   |
| 111 2500 | 102   | 24   | 111 2813 | 189   | 18   | 111 2858 | 161   | 21   |
| 111 2512 | 127   | 49   | 111 2813 | 191   | 73   | 111 2858 | 162   | 21   |
| 111 2515 | 331   | 39   | 111 2813 | 198   | 19   | 111 2858 | 163   | 10   |
| 111 2538 | 131   | 35   | 111 2813 | 199   | 18   | 111 2858 | 164   | 10   |
| 111 2538 | 148   | 15   | 111 2813 | 200   | 18   | 111 2858 | 230   | 19   |
| 111 2538 | 149   | 15   | 111 2813 | 202   | 9    | 111 2858 | 231   | 19   |
| 111 2538 | 204   | 10   | 111 2813 | 204   | 20   | 111 2858 | 233   | 10   |
| 111 2572 | 318   | 12   | 111 2813 | 205   | 17   | 111 2858 | 291   | 117  |
| 111 2572 | 319   | 6    | 111 2813 | 206   | 17   | 111 2858 | 296   | 117  |
| 111 2572 | 320   | 6    | 111 2813 | 207   | 3    | 111 2861 | 67    | 6    |
| 111 2596 | 279   | 20   | 111 2813 | 208   | 16   | 111 2861 | 136   | 7    |
| 111 2608 | 256   | 3    | 111 2813 | 211   | 34   | 111 2863 | 156   | 18   |
| 111 2624 | 144   | 8    | 111 2813 | 241   | 16   | 111 2863 | 161   | 20   |
| 111 2624 | 146   | 6    | 111 2813 | 261   | 4    | 111 2863 | 162   | 20   |
| 111 2624 | 148   | 22   | 111 2813 | 269   | 5    | 111 2863 | 163   | 9    |
| 111 2624 | 166   | 16   | 111 2813 | 274   | 12   | 111 2863 | 164   | 9    |
| 111 2624 | 167   | 17   | 111 2813 | 292   | 244  | 111 2870 | 152   | 75   |

| TEILE-NR | SEITE | BILD | TEILE-NR | SEITE | BILD | TEILE-NR | SEITE | BILD |
|----------|-------|------|----------|-------|------|----------|-------|------|
| 111 2874 | 231   | 33   | 111 5252 | 312   | 7    | 111 5503 | 167   | 15   |
| 111 2874 | 233   | 8    | 111 5316 | 246   | 32   | 111 5943 | 264   | 2    |
| 111 2874 | 314   | 6    | 111 5333 | 34    | 11   | 111 6029 | 322   | 54   |
| 111 2886 | 160   | 29   | 111 5333 | 326   | 38   | 111 6039 | 208   | 26   |
| 111 2886 | 303   | 12   | 111 5333 | 328   | 32   | 111 6624 | 277   | 33   |
| 111 2886 | 305   | 12   | 111 5350 | 163   | 8    | 111 6624 | 287   | 42   |
| 111 2886 | 336   | 6    | 111 5350 | 164   | 8    | 111 6626 | 275   | 6    |
| 111 2908 | 167   | 4    | 111 5360 | 208   | 17   | 111 6626 | 277   | 6    |
| 111 2908 | 313   | 17   | 111 5362 | 156   | 16   | 111 6627 | 279   | 30   |
| 111 2961 | 223   | 15   | 111 5363 | 97    | 23   | 111 6629 | 275   | 17   |
| 111 3146 | 59    | 16   | 111 5363 | 98    | 23   | 111 6629 | 277   | 17   |
| 111 3152 | 97    | 6    | 111 5363 | 99    | 17   | 111 6629 | 280   | 43   |
| 111 3152 | 99    | 11   | 111 5363 | 101   | 17   | 111 6632 | 302   | 16   |
| 111 3152 | 101   | 11   | 111 5363 | 161   | 19   | 111 6653 | 275   | 7    |
| 111 3152 | 165   | 35   | 111 5363 | 162   | 19   | 111 6653 | 277   | 7    |
| 111 3152 | 292   | 204  | 111 5400 | 282   | 7    | 111 6653 | 279   | 29   |
| 111 3152 | 297   | 204  | 111 5400 | 284   | 7    | 111 6656 | 275   | 16   |
| 111 3153 | 142   | 21   | 111 5405 | 323   | 22   | 111 6656 | 277   | 16   |
| 111 3153 | 143   | 21   | 111 5405 | 326   | 41   | 111 6656 | 280   | 44   |
| 111 3165 | 177   | 9    | 111 5405 | 327   | 22   | 111 6687 | 275   | 21   |
| 111 3165 | 179   | 10   | 111 5407 | 142   | 18   | 111 6687 | 277   | 21   |
| 111 3179 | 181   | 18   | 111 5407 | 143   | 18   | 111 6695 | 302   | 17   |
| 111 3179 | 181   | 22   | 111 5407 | 301   | 14   | 111 6709 | 287   | 43   |
| 111 3183 | 180   | 51   | 111 5415 | 93    | 25   | 111 6735 | 279   | 41   |
| 111 3183 | 335   | 104  | 111 5415 | 96    | 41   | 111 6956 | 115   | 19   |
| 111 3184 | 177   | 11   | 111 5418 | 311   | 13   | 111 6956 | 117   | 23   |
| 111 3185 | 185   | 101  | 111 5418 | 312   | 13   | 111 6956 | 119   | 23   |
| 111 3191 | 187   | 83   | 111 5420 | 207   | 34   | 111 6956 | 120   | 19   |
| 111 3195 | 177   | 19   | 111 5420 | 209   | 38   | 111 6956 | 122   | 23   |
| 111 3206 | 169   | 12   | 111 5423 | 156   | 41   | 111 6956 | 125   | 3    |
| 111 3206 | 171   | 12   | 111 5423 | 242   | 45   | 111 6956 | 126   | 27   |
| 111 3206 | 173   | 17   | 111 5423 | 243   | 14   | 111 6956 | 282   | 16   |
| 111 3206 | 175   | 15   | 111 5423 | 245   | 14   | 111 6956 | 284   | 29   |
| 111 3213 | 179   | 27   | 111 5430 | 208   | 27   | 111 7066 | 270   | 12   |
| 111 3218 | 184   | 22   | 111 5433 | 95    | 15   | 111 7131 | 136   | 16   |
| 111 3255 | 183   | 21   | 111 5433 | 241   | 28   | 111 7286 | 272   | 27   |
| 111 3255 | 187   | 61   | 111 5433 | 291   | 53   | 111 7371 | 107   | 9    |
| 111 3283 | 169   | 4    | 111 5433 | 296   | 53   | 111 7455 | 107   | 8    |
| 111 3283 | 171   | 4    | 111 5440 | 114   | 27   | 111 7455 | 110   | 12   |
| 111 3283 | 173   | 12   | 111 5440 | 290   | 23   | 111 7455 | 270   | 29   |
| 111 3283 | 175   | 7    | 111 5440 | 295   | 23   | 111 7455 | 272   | 24   |
| 111 3389 | 292   | 199  | 111 5443 | 95    | 4    | 111 7557 | 301   | 4    |
| 111 3389 | 297   | 199  | 111 5454 | 125   | 14   | 111 7617 | 139   | 33   |
| 111 3427 | 331   | 66   | 111 5455 | 126   | 23   | 111 7861 | 63    | 7    |
| 111 3427 | 334   | 66   | 111 5455 | 315   | 40   | 111 7875 | 230   | 20   |
| 111 3476 | 59    | 8    | 111 5456 | 115   | 26   | 111 7875 | 231   | 20   |
| 111 3477 | 153   | 167  | 111 5456 | 120   | 26   | 111 7929 | 244   | 35   |
| 111 3479 | 139   | 44   | 111 5458 | 139   | 31   | 111 7930 | 245   | 13   |
| 111 3963 | 173   | 8    | 111 5459 | 37    | 2    | 111 8015 | 128   | 22   |
| 111 3963 | 175   | 3    | 111 5459 | 97    | 5    | 111 8083 | 270   | 26   |
| 111 3997 | 313   | 18   | 111 5459 | 98    | 5    | 111 8098 | 131   | 28   |
| 111 4285 | 158   | 31   | 111 5459 | 107   | 37   | 111 8157 | 134   | 16   |
| 111 4356 | 301   | 8    | 111 5459 | 111   | 83   | 111 8323 | 291   | 85   |
| 111 4357 | 299   | 43   | 111 5459 | 119   | 59   | 111 8323 | 296   | 85   |
| 111 4357 | 300   | 43   | 111 5460 | 95    | 34   | 111 8325 | 311   | 14   |
| 111 4357 | 316   | 6    | 111 5461 | 99    | 69   | 111 8325 | 312   | 14   |
| 111 4815 | 242   | 63   | 111 5461 | 101   | 69   | 111 8376 | 127   | 42   |
| 111 5001 | 142   | 14   | 111 5464 | 49    | 6    | 111 8415 | 243   | 12   |
| 111 5001 | 143   | 14   | 111 5473 | 315   | 39   | 111 8415 | 245   | 3    |
| 111 5021 | 322   | 41   | 111 5479 | 292   | 185  | 111 8460 | 155   | 23   |
| 111 5036 | 94    | 33   | 111 5479 | 297   | 185  | 111 8475 | 158   | 33   |
| 111 5036 | 96    | 46   | 111 5503 | 166   | 13   | 111 8647 | 73    | 2    |

| TEILE-NR | SEITE | BILD | TEILE-NR | SEITE | BILD | TEILE-NR | SEITE | BILD |
|----------|-------|------|----------|-------|------|----------|-------|------|
| 111 8654 | 137   | 10   | 111 8760 | 55    | 19   | 111 9827 | 311   | 20   |
| 111 8659 | 139   | 84   | 111 8760 | 275   | 19   | 111 9827 | 312   | 20   |
| 111 8659 | 291   | 46   | 111 8760 | 277   | 19   | 112 0609 | 151   | 18   |
| 111 8659 | 295   | 46   | 111 8760 | 290   | 36   | 112 0618 | 138   | 21   |
| 111 8659 | 332   | 109  | 111 8760 | 295   | 36   | 112 0660 | 128   | 24   |
| 111 8659 | 335   | 109  | 111 8783 | 47    | 4    | 112 0677 | 148   | 12   |
| 111 8669 | 248   | 43   | 111 8784 | 280   | 59   | 112 0677 | 149   | 12   |
| 111 8673 | 34    | 7    | 111 8784 | 302   | 2    | 112 0694 | 132   | 33   |
| 111 8673 | 75    | 3    | 111 8956 | 325   | 32   | 112 0700 | 132   | 34   |
| 111 8673 | 114   | 23   | 111 8956 | 327   | 8    | 112 0936 | 207   | 9    |
| 111 8673 | 194   | 17   | 111 8963 | 195   | 13   | 112 0936 | 331   | 42   |
| 111 8673 | 325   | 33   | 111 8963 | 196   | 13   | 112 0947 | 208   | 18   |
| 111 8673 | 327   | 9    | 111 8965 | 280   | 61   | 112 1069 | 211   | 2    |
| 111 8673 | 332   | 107  | 111 8970 | 39    | 7    | 112 1249 | 212   | 45   |
| 111 8673 | 335   | 107  | 111 8970 | 128   | 11   | 112 1251 | 212   | 61   |
| 111 8681 | 102   | 25   | 111 8971 | 130   | 18   | 112 1253 | 212   | 46   |
| 111 8681 | 127   | 45   | 111 8971 | 291   | 70   | 112 1255 | 212   | 47   |
| 111 8688 | 194   | 4    | 111 8971 | 296   | 70   | 112 1285 | 331   | 61   |
| 111 8688 | 195   | 7    | 111 8979 | 102   | 5    | 112 1285 | 334   | 61   |
| 111 8688 | 196   | 7    | 111 8979 | 102   | 22   | 112 1327 | 212   | 73   |
| 111 8688 | 290   | 38   | 111 8979 | 103   | 11   | 112 1330 | 214   | 57   |
| 111 8688 | 295   | 38   | 111 8979 | 104   | 11   | 112 1330 | 216   | 57   |
| 111 8688 | 326   | 43   | 111 8979 | 114   | 25   | 112 1372 | 221   | 2    |
| 111 8688 | 327   | 16   | 111 8979 | 126   | 13   | 112 1372 | 222   | 2    |
| 111 8688 | 331   | 79   | 111 8980 | 46    | 4    | 112 1372 | 223   | 7    |
| 111 8688 | 334   | 79   | 111 8980 | 139   | 50   | 112 1373 | 221   | 6    |
| 111 8693 | 66    | 2    | 111 8989 | 47    | 5    | 112 1373 | 222   | 6    |
| 111 8693 | 71    | 2    | 111 8998 | 139   | 83   | 112 1373 | 223   | 8    |
| 111 8693 | 148   | 26   | 111 9231 | 73    | 3    | 112 1383 | 220   | 11   |
| 111 8693 | 149   | 26   | 111 9235 | 332   | 110  | 112 1395 | 224   | 3    |
| 111 8693 | 160   | 16   | 111 9235 | 335   | 110  | 112 1409 | 228   | 10   |
| 111 8707 | 34    | 4    | 111 9238 | 332   | 108  | 112 1409 | 229   | 12   |
| 111 8707 | 160   | 26   | 111 9238 | 335   | 108  | 112 1418 | 248   | 31   |
| 111 8707 | 280   | 62   | 111 9246 | 71    | 1    | 112 1418 | 263   | 5    |
| 111 8707 | 282   | 29   | 111 9246 | 160   | 21   | 112 1426 | 223   | 6    |
| 111 8707 | 284   | 11   | 111 9246 | 194   | 3    | 112 1432 | 203   | 5    |
| 111 8713 | 39    | 6    | 111 9246 | 195   | 8    | 112 1432 | 213   | 21   |
| 111 8713 | 128   | 9    | 111 9246 | 196   | 8    | 112 1432 | 218   | 21   |
| 111 8713 | 130   | 19   | 111 9246 | 334   | 78   | 112 1432 | 219   | 10   |
| 111 8713 | 275   | 22   | 111 9296 | 331   | 78   | 112 1438 | 226   | 5    |
| 111 8713 | 277   | 22   | 111 9302 | 89    | 2    | 112 1438 | 227   | 19   |
| 111 8713 | 281   | 14   | 111 9609 | 275   | 11   | 112 1444 | 226   | 6    |
| 111 8713 | 286   | 14   | 111 9609 | 277   | 11   | 112 1444 | 226   | 18   |
| 111 8713 | 291   | 69   | 111 9611 | 45    | 2    | 112 1627 | 197   | 10   |
| 111 8713 | 296   | 69   | 111 9611 | 124   | 31   | 112 1627 | 199   | 10   |
| 111 8713 | 325   | 31   | 111 9611 | 278   | 60   | 112 1627 | 201   | 10   |
| 111 8736 | 46    | 3    | 111 9613 | 236   | 7    | 112 1705 | 330   | 16   |
| 111 8737 | 102   | 4    | 111 9613 | 237   | 5    | 112 1705 | 333   | 16   |
| 111 8737 | 102   | 21   | 111 9613 | 275   | 4    | 112 1707 | 330   | 22   |
| 111 8737 | 103   | 9    | 111 9613 | 277   | 4    | 112 1707 | 333   | 22   |
| 111 8737 | 104   | 9    | 111 9615 | 291   | 114  | 112 1709 | 330   | 17   |
| 111 8737 | 114   | 26   | 111 9615 | 296   | 114  | 112 1709 | 333   | 17   |
| 111 8737 | 115   | 34   | 111 9628 | 212   | 48   | 112 1712 | 330   | 18   |
| 111 8737 | 117   | 29   | 111 9629 | 224   | 10   | 112 1712 | 333   | 18   |
| 111 8737 | 120   | 34   | 111 9630 | 212   | 62   | 112 1715 | 330   | 11   |
| 111 8737 | 122   | 29   | 111 9630 | 247   | 16   | 112 1715 | 333   | 11   |
| 111 8737 | 126   | 12   | 111 9632 | 214   | 73   | 112 1721 | 331   | 58   |
| 111 8737 | 137   | 2    | 111 9632 | 216   | 73   | 112 1721 | 334   | 58   |
| 111 8737 | 139   | 52   | 111 9824 | 115   | 16   | 112 1735 | 330   | 25   |
| 111 8737 | 331   | 75   | 111 9824 | 117   | 17   | 112 1735 | 333   | 25   |
| 111 8737 | 334   | 75   | 111 9824 | 120   | 16   | 112 1774 | 330   | 12   |
| 111 8750 | 39    | 2    | 111 9824 | 122   | 17   | 112 1774 | 333   | 12   |

| TEILE-NR | SEITE | BILD | TEILE-NR | SEITE | BILD | TEILE-NR | SEITE | BILD |
|----------|-------|------|----------|-------|------|----------|-------|------|
| 112 2274 | 108   | 83   | 112 3749 | 193   | 75   | 113 2679 | 318   | 15   |
| 112 2350 | 34    | 6    | 112 3749 | 191   | 76   | 113 2704 | 317   | 23   |
| 112 2351 | 148   | 27   | 112 3749 | 241   | 5    | 113 2704 | 318   | 23   |
| 112 2351 | 149   | 27   | 112 3749 | 274   | 14   | 113 2705 | 317   | 22   |
| 112 2361 | 102   | 10   | 112 3784 | 105   | 13   | 113 2705 | 318   | 22   |
| 112 2362 | 185   | 37   | 112 3860 | 290   | 34   | 113 3087 | 158   | 35   |
| 112 2363 | 105   | 6    | 112 3860 | 295   | 34   | 113 5946 | 186   | 8    |
| 112 2372 | 279   | 23   | 112 3958 | 326   | 42   | 113 6317 | 262   | 6    |
| 112 2399 | 95    | 23   | 112 3958 | 327   | 12   | 113 6341 | 300   | 85   |
| 112 2447 | 185   | 71   | 112 4043 | 228   | 4    | 113 6432 | 133   | 1    |
| 112 2458 | 182   | 41   | 112 4043 | 229   | 16   | 116 0024 | 61    | 6    |
| 112 2458 | 313   | 39   | 112 4654 | 191   | 51   | 116 0038 | 277   | 34   |
| 112 2477 | 87    | 4    | 112 4654 | 192   | 51   | 116 0038 | 291   | 54   |
| 112 2477 | 235   | 12   | 112 4659 | 185   | 58   | 116 0038 | 296   | 54   |
| 112 2477 | 237   | 9    | 112 4760 | 290   | 35   | 116 0039 | 290   | 24   |
| 112 2524 | 225   | 38   | 112 4760 | 295   | 35   | 116 0039 | 295   | 24   |
| 112 2569 | 275   | 12   | 112 4778 | 49    | 4    | 116 0044 | 290   | 28   |
| 112 2569 | 277   | 12   | 112 4782 | 299   | 6    | 116 0044 | 295   | 28   |
| 112 2817 | 277   | 32   | 112 4782 | 300   | 6    | 116 0062 | 107   | 26   |
| 112 2817 | 286   | 41   | 112 4803 | 168   | 6    | 116 0064 | 110   | 26   |
| 112 2822 | 278   | 86   | 112 4803 | 281   | 24   | 116 0075 | 277   | 23   |
| 112 2859 | 108   | 100  | 112 4811 | 321   | 9    | 116 0078 | 110   | 25   |
| 112 3048 | 247   | 27   | 112 4812 | 286   | 28   | 116 0079 | 110   | 37   |
| 112 3496 | 330   | 28   | 112 4823 | 183   | 7    | 116 0081 | 110   | 53   |
| 112 3496 | 333   | 28   | 112 5057 | 311   | 7    | 116 0082 | 110   | 50   |
| 112 3529 | 331   | 48   | 112 5312 | 309   | 5    | 116 0083 | 110   | 39   |
| 112 3529 | 334   | 48   | 112 5312 | 310   | 5    | 116 0097 | 34    | 20   |
| 112 3530 | 330   | 21   | 112 5504 | 330   | 26   | 116 0133 | 148   | 7    |
| 112 3530 | 333   | 21   | 112 5504 | 333   | 26   | 116 0133 | 149   | 7    |
| 112 3537 | 331   | 84   | 112 5635 | 254   | 12   | 116 0243 | 69    | 1    |
| 112 3538 | 330   | 20   | 112 5635 | 255   | 12   | 116 0252 | 252   | 10   |
| 112 3538 | 333   | 20   | 112 5674 | 272   | 6    | 116 0255 | 252   | 20   |
| 112 3539 | 331   | 85   | 112 5707 | 288   | 3    | 116 0256 | 252   | 30   |
| 112 3542 | 333   | 10   | 112 5780 | 138   | 13   | 116 0257 | 252   | 50   |
| 112 3543 | 330   | 9    | 112 5793 | 225   | 34   | 116 0286 | 281   | 13   |
| 112 3543 | 333   | 9    | 112 6001 | 242   | 62   | 116 0286 | 286   | 13   |
| 112 3545 | 330   | 13   | 112 6001 | 243   | 1    | 116 0286 | 326   | 49   |
| 112 3545 | 333   | 13   | 112 6001 | 245   | 1    | 116 0345 | 110   | 23   |
| 112 3546 | 144   | 14   | 112 6091 | 291   | 95   | 116 0346 | 110   | 1    |
| 112 3546 | 145   | 14   | 112 6138 | 279   | 22   | 116 0348 | 263   | 4    |
| 112 3546 | 146   | 12   | 112 6182 | 297   | 250  | 116 0500 | 126   | 24   |
| 112 3546 | 147   | 12   | 112 6235 | 260   | 7    | 116 0592 | 77    | 4    |
| 112 3546 | 148   | 29   | 112 6329 | 243   | 19   | 116 0678 | 128   | 2    |
| 112 3546 | 149   | 29   | 112 6329 | 245   | 17   | 116 0701 | 138   | 19   |
| 112 3582 | 189   | 8    | 112 6748 | 93    | 18   | 116 0770 | 128   | 19   |
| 112 3582 | 212   | 40   | 112 6749 | 95    | 38   | 116 0851 | 107   | 1    |
| 112 3627 | 177   | 20   | 112 6918 | 110   | 8    | 116 0854 | 144   | 7    |
| 112 3687 | 282   | 31   | 112 6975 | 229   | 6    | 116 0854 | 145   | 7    |
| 112 3687 | 284   | 23   | 112 6979 | 76    | 11   | 116 0857 | 146   | 9    |
| 112 3699 | 200   | 17   | 112 6979 | 87    | 15   | 116 0857 | 147   | 9    |
| 112 3700 | 223   | 3    | 112 7573 | 227   | 41   | 116 1002 | 110   | 5    |
| 112 3701 | 184   | 25   | 112 7709 | 242   | 47   | 116 1032 | 250   | 1    |
| 112 3701 | 323   | 41   | 112 8196 | 67    | 2    | 116 1084 | 53    | 6    |
| 112 3701 | 329   | 11   | 112 8250 | 246   | 34   | 116 1085 | 212   | 78   |
| 112 3702 | 324   | 46   | 112 8263 | 331   | 81   | 116 1085 | 221   | 18   |
| 112 3702 | 329   | 16   | 112 8263 | 334   | 81   | 116 1085 | 222   | 18   |
| 112 3703 | 324   | 49   | 112 8264 | 330   | 15   | 116 1089 | 53    | 7    |
| 112 3703 | 329   | 19   | 112 8264 | 333   | 15   | 116 1165 | 211   | 31   |
| 112 3718 | 87    | 3    | 112 8266 | 302   | 13   | 116 1302 | 249   | 3    |
| 112 3727 | 236   | 6    | 112 8273 | 274   | 4    | 116 1412 | 74    | 7    |
| 112 3727 | 237   | 4    | 113 0548 | 198   | 9    | 116 1469 | 70    | 5    |
| 112 3746 | 197   | 16   | 113 0548 | 200   | 12   | 116 1513 | 273   | 46   |

| TEILE-NR | SEITE | BILD | TEILE-NR | SEITE | BILD | TEILE-NR | SEITE | BILD |
|----------|-------|------|----------|-------|------|----------|-------|------|
| 116 1561 | 139   | 41   | 116 4377 | 214   | 56   | 116 6343 | 120   | 31   |
| 116 1562 | 139   | 42   | 116 4377 | 216   | 56   | 116 6343 | 275   | 42   |
| 116 1601 | 107   | 39   | 116 4377 | 219   | 14   | 116 6343 | 277   | 42   |
| 116 1602 | 110   | 49   | 116 4378 | 203   | 7    | 116 6345 | 115   | 18   |
| 116 1628 | 186   | 39   | 116 4378 | 212   | 51   | 116 6345 | 120   | 18   |
| 116 1629 | 181   | 37   | 116 4378 | 214   | 55   | 116 6346 | 117   | 21   |
| 116 1630 | 181   | 38   | 116 4378 | 215   | 55   | 116 6346 | 122   | 21   |
| 116 1630 | 186   | 38   | 116 4378 | 219   | 13   | 116 6347 | 117   | 20   |
| 116 1641 | 292   | 127  | 116 4422 | 214   | 78   | 116 6347 | 122   | 20   |
| 116 1641 | 296   | 127  | 116 4422 | 216   | 78   | 116 6376 | 302   | 14   |
| 116 1871 | 114   | 9    | 116 4587 | 219   | 2    | 116 6407 | 202   | 6    |
| 116 2041 | 293   | 286  | 116 4588 | 219   | 1    | 116 6417 | 197   | 11   |
| 116 2103 | 53    | 954  | 116 4674 | 216   | 83   | 116 6417 | 198   | 14   |
| 116 2104 | 53    | 953  | 116 4675 | 216   | 85   | 116 6417 | 199   | 11   |
| 116 2303 | 53    | 5    | 116 4749 | 212   | 86   | 116 6417 | 200   | 13   |
| 116 2367 | 211   | 28   | 116 4872 | 280   | 76   | 116 6417 | 201   | 11   |
| 116 2414 | 213   | 24   | 116 4873 | 280   | 78   | 116 6417 | 202   | 7    |
| 116 2414 | 215   | 24   | 116 4939 | 275   | 23   | 116 6836 | 139   | 40   |
| 116 2420 | 311   | 1    | 116 4939 | 279   | 27   | 116 6951 | 50    | 2    |
| 116 2420 | 312   | 1    | 116 4994 | 91    | 4    | 116 7010 | 49    | 8    |
| 116 2469 | 53    | 952  | 116 5272 | 155   | 10   | 116 7017 | 293   | 287  |
| 116 2717 | 330   | 6    | 116 5286 | 130   | 27   | 116 7052 | 303   | 36   |
| 116 2717 | 333   | 6    | 116 5397 | 198   | 8    | 116 7052 | 305   | 36   |
| 116 2727 | 107   | 64   | 116 5397 | 200   | 9    | 116 7153 | 198   | 24   |
| 116 2740 | 194   | 7    | 116 5397 | 202   | 24   | 116 7153 | 200   | 25   |
| 116 2820 | 300   | 83   | 116 5788 | 75    | 1    | 116 7158 | 128   | 23   |
| 116 2851 | 86    | 2    | 116 5789 | 74    | 5    | 116 7161 | 131   | 33   |
| 116 2924 | 211   | 30   | 116 5799 | 311   | 9    | 116 7164 | 130   | 8    |
| 116 2930 | 110   | 40   | 116 5799 | 312   | 9    | 116 7169 | 148   | 13   |
| 116 3008 | 90    | 1    | 116 5827 | 293   | 285  | 116 7169 | 149   | 13   |
| 116 3163 | 276   | 88   | 116 5827 | 298   | 294  | 116 7180 | 247   | 7    |
| 116 3204 | 211   | 29   | 116 5830 | 139   | 32   | 116 7193 | 197   | 17   |
| 116 3522 | 249   | 13   | 116 5836 | 128   | 7    | 116 7193 | 247   | 29   |
| 116 3642 | 116   | 57   | 116 5836 | 130   | 16   | 116 7193 | 323   | 24   |
| 116 3642 | 118   | 78   | 116 5842 | 293   | 282  | 116 7193 | 326   | 35   |
| 116 3642 | 121   | 57   | 116 5842 | 297   | 291  | 116 7193 | 327   | 29   |
| 116 3642 | 123   | 78   | 116 5851 | 107   | 28   | 116 7194 | 130   | 3    |
| 116 3730 | 213   | 22   | 116 5975 | 44    | 2    | 116 7194 | 188   | 11   |
| 116 3730 | 214   | 77   | 116 5997 | 129   | 33   | 116 7194 | 189   | 17   |
| 116 3730 | 215   | 22   | 116 6000 | 114   | 28   | 116 7194 | 261   | 5    |
| 116 3916 | 213   | 11   | 116 6000 | 115   | 14   | 116 7194 | 269   | 4    |
| 116 3916 | 215   | 11   | 116 6000 | 120   | 14   | 116 7194 | 274   | 13   |
| 116 3917 | 213   | 30   | 116 6002 | 62    | 2    | 116 7194 | 290   | 4    |
| 116 3918 | 213   | 31   | 116 6006 | 124   | 8    | 116 7204 | 150   | 8    |
| 116 3919 | 213   | 13   | 116 6006 | 125   | 12   | 116 7204 | 267   | 10   |
| 116 3920 | 213   | 8    | 116 6015 | 275   | 8    | 116 7214 | 270   | 1    |
| 116 3920 | 215   | 8    | 116 6015 | 277   | 8    | 116 7218 | 107   | 17   |
| 116 3921 | 213   | 29   | 116 6016 | 331   | 50   | 116 7222 | 107   | 68   |
| 116 3921 | 215   | 29   | 116 6016 | 334   | 50   | 116 7223 | 107   | 38   |
| 116 3922 | 213   | 6    | 116 6033 | 275   | 14   | 116 7223 | 110   | 2    |
| 116 3922 | 215   | 6    | 116 6033 | 277   | 14   | 116 7239 | 126   | 34   |
| 116 3942 | 42    | 4    | 116 6059 | 291   | 51   | 116 7261 | 131   | 31   |
| 116 3952 | 213   | 25   | 116 6059 | 296   | 51   | 116 7266 | 34    | 9    |
| 116 3952 | 215   | 25   | 116 6080 | 282   | 24   | 116 7308 | 249   | 7    |
| 116 3980 | 218   | 34   | 116 6080 | 284   | 9    | 116 7311 | 249   | 5    |
| 116 3984 | 86    | 1    | 116 6110 | 37    | 4    | 116 7311 | 292   | 224  |
| 116 3985 | 85    | 1    | 116 6110 | 40    | 2    | 116 7311 | 297   | 224  |
| 116 3993 | 110   | 35   | 116 6121 | 108   | 78   | 116 7312 | 249   | 8    |
| 116 4011 | 214   | 69   | 116 6121 | 111   | 71   | 116 7314 | 249   | 4    |
| 116 4153 | 302   | 12   | 116 6126 | 107   | 59   | 116 7315 | 249   | 12   |
| 116 4377 | 203   | 8    | 116 6126 | 111   | 61   | 116 7316 | 249   | 1    |
| 116 4377 | 212   | 52   | 116 6343 | 115   | 31   | 116 7320 | 302   | 19   |

| TEILE-NR | SEITE | BILD | TEILE-NR | SEITE | BILD | TEILE-NR | SEITE | BILD |
|----------|-------|------|----------|-------|------|----------|-------|------|
| 116 7323 | 249   | 9    | 116 8559 | 248   | 35   | 116 9689 | 110   | 9    |
| 116 7325 | 102   | 9    | 116 8681 | 130   | 25   | 116 9689 | 117   | 33   |
| 116 7325 | 103   | 20   | 116 8682 | 130   | 22   | 116 9689 | 122   | 33   |
| 116 7325 | 104   | 20   | 116 8683 | 130   | 12   | 116 9689 | 125   | 9    |
| 116 7326 | 212   | 53   | 116 8684 | 130   | 14   | 116 9689 | 134   | 14   |
| 116 7333 | 249   | 2    | 116 8713 | 111   | 112  | 116 9689 | 155   | 7    |
| 116 7412 | 212   | 42   | 116 8715 | 270   | 2    | 116 9689 | 188   | 7    |
| 116 7421 | 224   | 8    | 116 8717 | 114   | 30   | 116 9689 | 189   | 14   |
| 116 7425 | 78    | 10   | 116 8730 | 114   | 17   | 116 9689 | 197   | 8    |
| 116 7425 | 82    | 10   | 116 8738 | 107   | 11   | 116 9689 | 201   | 8    |
| 116 7425 | 212   | 64   | 116 8738 | 111   | 90   | 116 9689 | 204   | 8    |
| 116 7427 | 189   | 12   | 116 8741 | 110   | 24   | 116 9689 | 235   | 14   |
| 116 7498 | 270   | 21   | 116 8744 | 107   | 47   | 116 9689 | 247   | 11   |
| 116 7498 | 272   | 21   | 116 8749 | 126   | 16   | 116 9689 | 290   | 8    |
| 116 7503 | 126   | 4    | 116 8761 | 110   | 30   | 116 9689 | 295   | 8    |
| 116 7917 | 302   | 1    | 116 8762 | 110   | 3    | 116 9694 | 102   | 1    |
| 116 7962 | 280   | 75   | 116 8764 | 111   | 111  | 116 9694 | 107   | 74   |
| 116 7971 | 280   | 77   | 116 8778 | 126   | 17   | 116 9694 | 111   | 59   |
| 116 8145 | 331   | 80   | 116 8791 | 107   | 27   | 116 9694 | 156   | 12   |
| 116 8145 | 334   | 80   | 116 8792 | 107   | 2    | 116 9694 | 168   | 7    |
| 116 8224 | 97    | 12   | 116 8817 | 55    | 5    | 116 9694 | 231   | 65   |
| 116 8224 | 99    | 7    | 116 8863 | 251   | 2    | 116 9694 | 233   | 26   |
| 116 8224 | 308   | 7    | 116 8865 | 251   | 1    | 116 9694 | 235   | 3    |
| 116 8224 | 309   | 7    | 116 8869 | 252   | 2    | 116 9694 | 299   | 5    |
| 116 8224 | 310   | 7    | 116 8871 | 252   | 3    | 116 9695 | 102   | 3    |
| 116 8224 | 311   | 10   | 116 8880 | 252   | 8    | 116 9695 | 102   | 23   |
| 116 8224 | 312   | 10   | 116 8881 | 252   | 12   | 116 9695 | 131   | 36   |
| 116 8224 | 315   | 41   | 116 8964 | 211   | 9    | 116 9696 | 102   | 2    |
| 116 8224 | 316   | 3    | 116 9028 | 212   | 87   | 116 9696 | 181   | 4    |
| 116 8225 | 97    | 16   | 116 9030 | 211   | 23   | 116 9696 | 183   | 8    |
| 116 8225 | 98    | 16   | 116 9031 | 249   | 10   | 116 9696 | 186   | 5    |
| 116 8225 | 99    | 41   | 116 9032 | 249   | 11   | 116 9697 | 130   | 6    |
| 116 8225 | 101   | 41   | 116 9062 | 212   | 76   | 116 9697 | 336   | 5    |
| 116 8225 | 139   | 39   | 116 9062 | 221   | 16   | 116 9738 | 326   | 64   |
| 116 8225 | 148   | 25   | 116 9062 | 222   | 16   | 116 9740 | 270   | 45   |
| 116 8225 | 149   | 25   | 116 9065 | 203   | 6    | 116 9761 | 323   | 12   |
| 116 8225 | 156   | 21   | 116 9070 | 214   | 61   | 116 9761 | 325   | 22   |
| 116 8225 | 160   | 2    | 116 9070 | 216   | 61   | 116 9761 | 327   | 25   |
| 116 8225 | 161   | 23   | 116 9070 | 226   | 8    | 116 9763 | 323   | 14   |
| 116 8225 | 162   | 23   | 116 9070 | 227   | 21   | 116 9763 | 325   | 26   |
| 116 8225 | 163   | 16   | 116 9070 | 331   | 34   | 116 9763 | 327   | 30   |
| 116 8225 | 164   | 16   | 116 9070 | 334   | 34   | 116 9763 | 329   | 3    |
| 116 8225 | 171   | 14   | 116 9232 | 213   | 10   | 116 9764 | 323   | 13   |
| 116 8225 | 173   | 19   | 116 9232 | 215   | 10   | 116 9764 | 325   | 25   |
| 116 8225 | 175   | 17   | 116 9304 | 211   | 20   | 116 9764 | 327   | 28   |
| 116 8225 | 183   | 34   | 116 9338 | 216   | 82   | 116 9764 | 329   | 2    |
| 116 8225 | 186   | 11   | 116 9436 | 212   | 67   | 116 9835 | 280   | 42   |
| 116 8225 | 187   | 64   | 116 9436 | 212   | 77   | 116 9865 | 287   | 53   |
| 116 8225 | 187   | 98   | 116 9436 | 213   | 23   | 116 9947 | 252   | 17   |
| 116 8225 | 258   | 25   | 116 9436 | 215   | 23   | 117 0426 | 212   | 37   |
| 116 8226 | 153   | 86   | 116 9436 | 219   | 11   | 117 0485 | 282   | 38   |
| 116 8226 | 153   | 155  | 116 9436 | 221   | 17   | 117 0485 | 284   | 19   |
| 116 8227 | 105   | 14   | 116 9436 | 222   | 17   | 117 0580 | 49    | 7    |
| 116 8227 | 137   | 6    | 116 9479 | 130   | 5    | 117 0600 | 107   | 67   |
| 116 8227 | 169   | 15   | 116 9587 | 280   | 56   | 117 0642 | 70    | 6    |
| 116 8227 | 171   | 15   | 116 9588 | 139   | 23   | 117 0652 | 88    | 1    |
| 116 8227 | 173   | 20   | 116 9594 | 275   | 41   | 117 1244 | 302   | 24   |
| 116 8227 | 175   | 18   | 116 9594 | 277   | 41   | 117 1411 | 216   | 69   |
| 116 8229 | 157   | 8    | 116 9634 | 34    | 16   | 117 1916 | 216   | 93   |
| 116 8255 | 169   | 14   | 116 9672 | 300   | 86   | 117 1918 | 216   | 94   |
| 116 8255 | 187   | 85   | 116 9689 | 60    | 3    | 117 2065 | 212   | 85   |
| 116 8501 | 92    | 1    | 116 9689 | 107   | 7    | 117 2223 | 271   | 52   |



| TEILE-NR | SEITE | BILD | TEILE-NR | SEITE | BILD | TEILE-NR | SEITE | BILD |
|----------|-------|------|----------|-------|------|----------|-------|------|
| 117 2223 | 273   | 56   | 121 1590 | 267   | 11   | 121 6500 | 63    | 2    |
| 117 2278 | 276   | 93   | 121 1650 | 265   | 17   | 121 6511 | 64    | 3    |
| 117 2278 | 278   | 93   | 121 1692 | 138   | 9    | 121 6512 | 63    | 3    |
| 117 2311 | 54    | 958  | 121 1693 | 138   | 10   | 121 6884 | 58    | 3    |
| 117 2312 | 54    | 957  | 121 2263 | 265   | 10   | 121 6889 | 248   | 37   |
| 117 2313 | 54    | 959  | 121 2263 | 267   | 13   | 121 7068 | 265   | 16   |
| 121 0091 | 265   | 12   | 121 2742 | 331   | 77   | 121 7068 | 268   | 25   |
| 121 0091 | 267   | 20   | 121 2742 | 334   | 77   | 121 8017 | 190   | 7    |
| 121 0197 | 248   | 48   | 121 2896 | 213   | 15   | 121 8017 | 265   | 8    |
| 121 0432 | 211   | 10   | 121 2896 | 215   | 15   | 121 8034 | 260   | 4    |
| 121 0566 | 213   | 20   | 121 2994 | 191   | 52   | 121 8410 | 252   | 24   |
| 121 0566 | 215   | 20   | 121 2994 | 265   | 6    | 121 8425 | 272   | 28   |
| 121 0566 | 263   | 12   | 121 2995 | 191   | 53   | 121 8437 | 139   | 51   |
| 121 0596 | 275   | 49   | 121 2995 | 265   | 5    | 121 9657 | 125   | 18   |
| 121 0596 | 278   | 49   | 121 2996 | 191   | 54   | 123 5136 | 333   | 4    |
| 121 0622 | 265   | 13   | 121 2996 | 265   | 4    | 123 6290 | 43    | 2    |
| 121 0622 | 267   | 21   | 121 3282 | 185   | 75   | 123 6291 | 43    | 1    |
| 121 0622 | 299   | 35   | 121 3712 | 265   | 18   | 124 3184 | 71    | 3    |
| 121 0622 | 300   | 35   | 121 3712 | 267   | 22   | 124 4823 | 194   | 16   |
| 121 0643 | 266   | 954  | 121 3712 | 274   | 20   | 126 0070 | 95    | 11   |
| 121 0643 | 268   | 954  | 121 3748 | 267   | 2    | 126 0634 | 332   | 97   |
| 121 0643 | 299   | 36   | 121 4375 | 315   | 11   | 126 0634 | 334   | 100  |
| 121 0643 | 300   | 36   | 121 4582 | 193   | 76   | 126 2510 | 121   | 66   |
| 121 0644 | 265   | 951  | 121 4582 | 191   | 77   | 126 2510 | 123   | 87   |
| 121 0644 | 268   | 951  | 121 4679 | 263   | 15   | 126 2637 | 275   | 67   |
| 121 0644 | 299   | 37   | 121 4737 | 267   | 3    | 126 2637 | 278   | 67   |
| 121 0644 | 300   | 37   | 121 4950 | 267   | 5    | 126 2639 | 276   | 68   |
| 121 0645 | 266   | 953  | 121 4951 | 267   | 9    | 126 2639 | 278   | 68   |
| 121 0645 | 268   | 953  | 121 4952 | 267   | 8    | 126 6006 | 279   | 26   |
| 121 0645 | 299   | 38   | 121 4988 | 34    | 3    | 126 6159 | 71    | 4    |
| 121 0645 | 300   | 38   | 121 4995 | 267   | 17   | 126 6161 | 195   | 9    |
| 121 0646 | 265   | 952  | 121 4996 | 267   | 15   | 126 6161 | 196   | 9    |
| 121 0646 | 268   | 952  | 121 4997 | 268   | 28   | 126 6401 | 94    | 36   |
| 121 0646 | 299   | 39   | 121 4998 | 267   | 16   | 126 6675 | 280   | 60   |
| 121 0646 | 300   | 39   | 121 4999 | 267   | 14   | 126 6675 | 302   | 5    |
| 121 0647 | 265   | 950  | 121 5235 | 34    | 5    | 127 6020 | 220   | 26   |
| 121 0647 | 268   | 950  | 121 5500 | 55    | 9    | 127 6020 | 221   | 27   |
| 121 0647 | 299   | 40   | 121 5748 | 87    | 8    | 127 6020 | 223   | 28   |
| 121 0647 | 300   | 40   | 121 5749 | 87    | 9    | 127 6020 | 225   | 25   |
| 121 0674 | 190   | 29   | 121 5850 | 78    | 3    | 127 6024 | 223   | 23   |
| 121 0674 | 222   | 21   | 121 5850 | 81    | 4    | 129 8473 | 276   | 101  |
| 121 0674 | 267   | 6    | 121 5850 | 82    | 3    | 129 8473 | 278   | 101  |
| 121 0675 | 190   | 6    | 121 5909 | 136   | 13   | 129 8722 | 276   | 102  |
| 121 0675 | 265   | 7    | 121 5993 | 174   | 42   | 129 8722 | 278   | 102  |
| 121 0752 | 265   | 11   | 121 5993 | 175   | 42   | 130 0154 | 276   | 100  |
| 121 0790 | 190   | 30   | 121 6035 | 134   | 62   | 130 0154 | 278   | 100  |
| 121 0790 | 192   | 30   | 121 6055 | 131   | 32   | 130 0174 | 276   | 103  |
| 121 0873 | 95    | 24   | 121 6057 | 108   | 102  | 130 0174 | 278   | 103  |
| 121 0937 | 114   | 16   | 121 6057 | 111   | 66   | 139 0702 | 228   | 11   |
| 121 1000 | 267   | 7    | 121 6080 | 59    | 7    | 139 3288 | 332   | 93   |
| 121 1098 | 190   | 12   | 121 6107 | 34    | 17   | 139 3288 | 334   | 98   |
| 121 1098 | 192   | 12   | 121 6110 | 87    | 16   | 140 0680 | 202   | 3    |
| 121 1099 | 190   | 23   | 121 6119 | 49    | 5    | 140 0962 | 42    | 3    |
| 121 1100 | 190   | 34   | 121 6124 | 252   | 27   | 210 1006 | 36    | 2    |
| 121 1206 | 67    | 1    | 121 6128 | 50    | 3    | 210 1007 | 36    | 3    |
| 121 1206 | 87    | 10   | 121 6143 | 195   | 11   | 210 1221 | 68    | 4    |
| 121 1299 | 194   | 20   | 121 6143 | 196   | 11   | 210 1222 | 58    | 1    |
| 121 1590 | 197   | 20   | 121 6185 | 126   | 26   | 210 1292 | 42    | 1    |
| 121 1590 | 198   | 13   | 121 6189 | 107   | 77   | 210 1390 | 47    | 6    |
| 121 1590 | 199   | 14   | 121 6240 | 34    | 8    | 210 1679 | 56    | 958  |
| 121 1590 | 200   | 23   | 121 6307 | 57    | 2    | 210 1680 | 56    | 959  |
| 121 1590 | 265   | 9    | 121 6492 | 73    | 4    | 210 1681 | 55    | 21   |

| TEILE-NR | SEITE | BILD | TEILE-NR | SEITE | BILD | TEILE-NR | SEITE | BILD |
|----------|-------|------|----------|-------|------|----------|-------|------|
| 210 1698 | 82    | 9    | 213 7096 | 55    | 17   | 223 0637 | 49    | 955  |
| 210 1700 | 79    | 5    | 213 7300 | 55    | 7    | 223 0849 | 59    | 13   |
| 210 1702 | 80    | 1    | 213 7301 | 55    | 8    | 223 0850 | 59    | 17   |
| 210 1802 | 79    | 1    | 213 7302 | 55    | 12   | 223 0851 | 59    | 20   |
| 210 1805 | 78    | 11   | 213 7303 | 56    | 955  | 223 1082 | 34    | 10   |
| 210 1937 | 42    | 2    | 213 7304 | 56    | 956  | 223 1154 | 55    | 1    |
| 210 2217 | 81    | 1    | 213 7305 | 56    | 957  | 223 1362 | 76    | 14   |
| 210 2238 | 201   | 1    | 213 7306 | 55    | 11   | 223 1363 | 76    | 1    |
| 210 2239 | 202   | 1    | 213 7307 | 56    | 952  | 223 1469 | 53    | 955  |
| 210 2528 | 201   | 12   | 213 7308 | 56    | 953  | 223 1470 | 53    | 956  |
| 210 2528 | 202   | 20   | 213 7309 | 56    | 954  | 223 1844 | 48    | 2    |
| 210 2529 | 201   | 13   | 213 7358 | 77    | 1    | 223 1924 | 48    | 1    |
| 210 2529 | 202   | 21   | 213 7519 | 72    | 1    | 223 1975 | 48    | 950  |
| 210 2530 | 201   | 14   | 213 7568 | 68    | 2    | 224 2031 | 84    | 4    |
| 210 2530 | 202   | 22   | 213 7580 | 55    | 16   | 230 0244 | 157   | 19   |
| 210 2531 | 201   | 15   | 213 7591 | 55    | 14   | 230 0750 | 331   | 52   |
| 210 2531 | 202   | 23   | 213 7737 | 49    | 950  | 230 0750 | 334   | 52   |
| 210 2532 | 201   | 16   | 213 7738 | 49    | 951  | 230 0897 | 282   | 13   |
| 210 2536 | 201   | 17   | 213 7750 | 52    | 4    | 230 0897 | 284   | 16   |
| 210 3307 | 335   | 106  | 213 7754 | 52    | 950  | 230 0899 | 282   | 18   |
| 213 0375 | 60    | 4    | 213 7758 | 52    | 951  | 230 0899 | 284   | 10   |
| 213 0440 | 60    | 1    | 213 7762 | 52    | 952  | 230 0901 | 282   | 28   |
| 213 0498 | 219   | 12   | 213 7766 | 52    | 953  | 230 0901 | 284   | 22   |
| 213 0507 | 45    | 1    | 213 7770 | 52    | 954  | 230 0903 | 282   | 3    |
| 213 1081 | 51    | 3    | 213 7774 | 52    | 955  | 230 0903 | 284   | 2    |
| 213 1081 | 65    | 3    | 213 7842 | 34    | 21   | 230 0906 | 282   | 1    |
| 213 1611 | 46    | 7    | 213 7912 | 68    | 3    | 230 0906 | 290   | 41   |
| 213 3557 | 195   | 17   | 213 7916 | 70    | 1    | 230 0906 | 295   | 41   |
| 213 3557 | 196   | 17   | 213 7917 | 70    | 2    | 230 1124 | 331   | 67   |
| 213 3558 | 195   | 15   | 213 7918 | 70    | 3    | 230 1124 | 334   | 67   |
| 213 3558 | 196   | 15   | 213 7996 | 73    | 1    | 230 1129 | 332   | 95   |
| 213 3559 | 195   | 18   | 213 8184 | 34    | 18   | 230 1129 | 334   | 96   |
| 213 3559 | 196   | 18   | 213 8185 | 34    | 19   | 230 1131 | 332   | 92   |
| 213 3560 | 195   | 19   | 213 9284 | 67    | 3    | 230 1131 | 334   | 95   |
| 213 3560 | 196   | 19   | 213 9287 | 67    | 4    | 230 1137 | 279   | 1    |
| 213 3561 | 195   | 20   | 213 9600 | 59    | 19   | 230 1139 | 280   | 51   |
| 213 3561 | 196   | 20   | 213 9737 | 34    | 14   | 230 1158 | 181   | 21   |
| 213 3562 | 195   | 16   | 216 0782 | 65    | 1    | 230 1172 | 111   | 106  |
| 213 3562 | 196   | 16   | 216 2497 | 51    | 1    | 230 1206 | 111   | 105  |
| 213 3633 | 76    | 4    | 216 3249 | 205   | 9    | 230 1216 | 124   | 18   |
| 213 3636 | 76    | 8    | 216 5716 | 63    | 1    | 230 1230 | 303   | 17   |
| 213 3781 | 37    | 3    | 216 6129 | 87    | 1    | 230 1230 | 305   | 17   |
| 213 3809 | 53    | 4    | 216 6479 | 203   | 1    | 230 1250 | 292   | 177  |
| 213 3871 | 52    | 5    | 216 6516 | 87    | 2    | 230 1250 | 292   | 265  |
| 213 3985 | 59    | 2    | 216 6522 | 89    | 1    | 230 1250 | 297   | 177  |
| 213 4336 | 331   | 53   | 216 8564 | 201   | 2    | 230 1250 | 297   | 273  |
| 213 4336 | 334   | 53   | 223 0134 | 49    | 9    | 230 1251 | 291   | 48   |
| 213 4337 | 50    | 1    | 223 0170 | 34    | 13   | 230 1251 | 292   | 264  |
| 213 5002 | 66    | 1    | 223 0172 | 35    | 960  | 230 1251 | 296   | 48   |
| 213 5335 | 61    | 5    | 223 0173 | 35    | 961  | 230 1251 | 297   | 272  |
| 213 5532 | 74    | 6    | 223 0174 | 35    | 962  | 230 1355 | 303   | 1    |
| 213 5902 | 76    | 7    | 223 0175 | 35    | 963  | 230 1355 | 305   | 1    |
| 213 5910 | 57    | 5    | 223 0181 | 34    | 12   | 230 1362 | 311   | 8    |
| 213 6027 | 37    | 1    | 223 0182 | 35    | 956  | 230 1362 | 312   | 8    |
| 213 6101 | 52    | 2    | 223 0183 | 35    | 957  | 230 1363 | 311   | 2    |
| 213 6359 | 62    | 1    | 223 0184 | 35    | 958  | 230 1363 | 312   | 2    |
| 213 6526 | 52    | 1    | 223 0185 | 35    | 959  | 230 1364 | 311   | 18   |
| 213 6596 | 55    | 18   | 223 0292 | 53    | 951  | 230 1364 | 312   | 18   |
| 213 6596 | 55    | 20   | 223 0526 | 34    | 1    | 230 1365 | 311   | 11   |
| 213 6928 | 49    | 1    | 223 0634 | 49    | 952  | 230 1365 | 312   | 11   |
| 213 6952 | 53    | 1    | 223 0635 | 49    | 953  | 230 1501 | 117   | 10   |
| 213 6958 | 53    | 950  | 223 0636 | 49    | 954  | 230 1502 | 117   | 16   |

| TEILE-NR | SEITE | BILD | TEILE-NR | SEITE | BILD | TEILE-NR | SEITE | BILD |
|----------|-------|------|----------|-------|------|----------|-------|------|
| 230 1515 | 167   | 2    | 230 4111 | 247   | 3    | 230 6227 | 139   | 28   |
| 230 1516 | 182   | 42   | 230 4112 | 247   | 4    | 230 6235 | 138   | 20   |
| 230 1516 | 186   | 42   | 230 4120 | 231   | 25   | 230 6238 | 139   | 27   |
| 230 1561 | 142   | 13   | 230 4120 | 233   | 6    | 230 6240 | 139   | 35   |
| 230 1561 | 143   | 13   | 230 4160 | 190   | 18   | 230 6241 | 139   | 36   |
| 230 1603 | 186   | 18   | 230 4160 | 192   | 18   | 230 6242 | 139   | 29   |
| 230 1711 | 272   | 9    | 230 4188 | 190   | 19   | 230 6244 | 139   | 30   |
| 230 1712 | 273   | 950  | 230 4188 | 192   | 19   | 230 6245 | 142   | 11   |
| 230 1713 | 273   | 951  | 230 4189 | 190   | 21   | 230 6245 | 143   | 11   |
| 230 1714 | 273   | 952  | 230 4189 | 192   | 21   | 230 6246 | 142   | 9    |
| 230 1715 | 273   | 953  | 230 4190 | 190   | 22   | 230 6246 | 143   | 9    |
| 230 1716 | 273   | 954  | 230 4190 | 192   | 22   | 230 6247 | 142   | 10   |
| 230 1717 | 273   | 955  | 230 4203 | 190   | 13   | 230 6247 | 143   | 10   |
| 230 1853 | 111   | 107  | 230 4203 | 192   | 13   | 230 6251 | 142   | 8    |
| 230 1889 | 110   | 10   | 230 4481 | 247   | 17   | 230 6256 | 142   | 12   |
| 230 1891 | 110   | 33   | 230 4486 | 212   | 65   | 230 6256 | 143   | 12   |
| 230 1895 | 110   | 15   | 230 4514 | 188   | 8    | 230 6257 | 142   | 6    |
| 230 1896 | 110   | 13   | 230 4514 | 189   | 15   | 230 6257 | 143   | 6    |
| 230 1897 | 110   | 28   | 230 4564 | 189   | 2    | 230 6258 | 142   | 5    |
| 230 2045 | 110   | 27   | 230 4568 | 190   | 9    | 230 6258 | 143   | 5    |
| 230 2046 | 111   | 958  | 230 4568 | 192   | 9    | 230 6262 | 162   | 18   |
| 230 2047 | 111   | 959  | 230 4865 | 247   | 1    | 230 6262 | 164   | 29   |
| 230 2048 | 111   | 960  | 230 4920 | 234   | 30   | 230 6264 | 162   | 17   |
| 230 2049 | 112   | 961  | 230 4946 | 230   | 3    | 230 6264 | 164   | 20   |
| 230 2050 | 112   | 962  | 230 4947 | 230   | 4    | 230 6266 | 162   | 15   |
| 230 2051 | 112   | 963  | 230 4958 | 231   | 30   | 230 6267 | 162   | 14   |
| 230 2055 | 110   | 7    | 230 4958 | 234   | 29   | 230 6292 | 313   | 24   |
| 230 2056 | 111   | 950  | 230 4962 | 232   | 85   | 230 6294 | 139   | 26   |
| 230 2057 | 111   | 951  | 230 4980 | 231   | 34   | 230 6297 | 138   | 16   |
| 230 2058 | 111   | 952  | 230 4980 | 233   | 15   | 230 6304 | 338   | 1    |
| 230 2059 | 111   | 953  | 230 4981 | 231   | 35   | 230 6306 | 338   | 2    |
| 230 2060 | 111   | 954  | 230 4981 | 233   | 16   | 230 6322 | 269   | 1    |
| 230 2061 | 111   | 955  | 230 4987 | 230   | 40   | 230 6326 | 220   | 3    |
| 230 2062 | 111   | 956  | 230 4987 | 231   | 40   | 230 6326 | 221   | 3    |
| 230 2063 | 111   | 957  | 230 4987 | 234   | 40   | 230 6326 | 222   | 3    |
| 230 2119 | 124   | 14   | 230 5008 | 159   | 3    | 230 6327 | 220   | 4    |
| 230 2123 | 124   | 23   | 230 5009 | 159   | 4    | 230 6327 | 221   | 4    |
| 230 2205 | 240   | 6    | 230 5010 | 159   | 6    | 230 6327 | 222   | 4    |
| 230 2205 | 241   | 8    | 230 5011 | 159   | 5    | 230 6328 | 220   | 5    |
| 230 2212 | 117   | 35   | 230 5217 | 225   | 21   | 230 6328 | 221   | 5    |
| 230 2212 | 122   | 35   | 230 5218 | 225   | 22   | 230 6336 | 226   | 13   |
| 230 2213 | 117   | 36   | 230 5219 | 225   | 24   | 230 6337 | 226   | 14   |
| 230 2213 | 122   | 36   | 230 5220 | 225   | 26   | 230 6338 | 226   | 3    |
| 230 2258 | 148   | 9    | 230 5221 | 225   | 28   | 230 6339 | 226   | 1    |
| 230 2258 | 149   | 9    | 230 5223 | 225   | 30   | 230 6341 | 226   | 15   |
| 230 2259 | 148   | 11   | 230 5224 | 225   | 62   | 230 6341 | 229   | 9    |
| 230 2259 | 149   | 11   | 230 5289 | 95    | 2    | 230 6342 | 227   | 20   |
| 230 2351 | 110   | 20   | 230 5290 | 95    | 3    | 230 6342 | 229   | 7    |
| 230 2352 | 110   | 52   | 230 5291 | 95    | 6    | 230 6343 | 226   | 7    |
| 230 2353 | 110   | 17   | 230 5293 | 95    | 7    | 230 6343 | 228   | 7    |
| 230 2386 | 110   | 14   | 230 5296 | 95    | 9    | 230 6525 | 290   | 27   |
| 230 2835 | 212   | 80   | 230 5298 | 95    | 12   | 230 6525 | 295   | 27   |
| 230 3194 | 117   | 40   | 230 5299 | 95    | 14   | 230 6574 | 291   | 97   |
| 230 3194 | 122   | 40   | 230 5301 | 309   | 13   | 230 6574 | 296   | 97   |
| 230 3354 | 276   | 69   | 230 5301 | 310   | 13   | 230 6576 | 282   | 37   |
| 230 3440 | 110   | 45   | 230 5306 | 309   | 12   | 230 6576 | 284   | 20   |
| 230 3557 | 299   | 1    | 230 5306 | 310   | 12   | 230 6581 | 293   | 305  |
| 230 3566 | 110   | 18   | 230 5312 | 303   | 28   | 230 6581 | 298   | 300  |
| 230 3570 | 110   | 16   | 230 5367 | 95    | 10   | 230 6597 | 293   | 284  |
| 230 3572 | 115   | 12   | 230 5367 | 101   | 10   | 230 6597 | 298   | 293  |
| 230 3581 | 265   | 2    | 230 6223 | 139   | 47   | 230 6602 | 292   | 167  |
| 230 3582 | 265   | 1    | 230 6225 | 138   | 8    | 230 6602 | 297   | 167  |

| TEILE-NR | SEITE | BILD | TEILE-NR | SEITE | BILD | TEILE-NR  | SEITE | BILD |
|----------|-------|------|----------|-------|------|-----------|-------|------|
| 230 6604 | 290   | 13   | 230 6973 | 155   | 14   | 230 925 2 | 112   | 964  |
| 230 6604 | 295   | 13   | 230 7055 | 93    | 31   | 230 929 8 | 97    | 22   |
| 230 6631 | 226   | 12   | 230 7055 | 96    | 44   | 230 929 8 | 100   | 72   |
| 230 6632 | 226   | 11   | 230 7064 | 96    | 42   | 230 930 6 | 169   | 8    |
| 230 6705 | 99    | 9    | 230 7083 | 155   | 15   | 230 938 6 | 167   | 8    |
| 230 6705 | 101   | 9    | 230 7084 | 155   | 20   | 230 951 7 | 148   | 8    |
| 230 6730 | 140   | 989  | 230 7084 | 155   | 20   | 230 951 7 | 149   | 8    |
| 230 6732 | 140   | 985  | 230 7085 | 155   | 17   | 230 964 7 | 93    | 28   |
| 230 6733 | 140   | 986  | 230 7086 | 155   | 18   | 230 964 8 | 93    | 16   |
| 230 6734 | 140   | 987  | 230 7087 | 155   | 21   | 230 964 9 | 93    | 30   |
| 230 6735 | 140   | 988  | 230 7088 | 155   | 22   | 230 965 0 | 93    | 17   |
| 230 6739 | 138   | 17   | 230 7268 | 110   | 32   | 230 965 2 | 93    | 32   |
| 230 6739 | 139   | 950  | 230 7445 | 139   | 43   | 230 965 3 | 93    | 19   |
| 230 6740 | 139   | 951  | 230 7519 | 133   | 24   | 230 965 4 | 94    | 43   |
| 230 6740 | 140   | 984  | 230 7567 | 270   | 37   | 230 965 5 | 93    | 21   |
| 230 6741 | 139   | 952  | 230 7571 | 111   | 69   | 230 965 6 | 93    | 29   |
| 230 6742 | 139   | 953  | 230 7578 | 272   | 5    | 230 965 7 | 93    | 22   |
| 230 6743 | 139   | 954  | 230 7580 | 272   | 7    | 230 965 8 | 93    | 24   |
| 230 6745 | 139   | 955  | 230 7582 | 102   | 15   | 230 968 2 | 273   | 47   |
| 230 6746 | 140   | 956  | 230 7582 | 271   | 49   | 230 968 3 | 273   | 48   |
| 230 6747 | 140   | 957  | 230 7582 | 272   | 10   | 230 968 3 | 273   | 48   |
| 230 6748 | 140   | 958  | 230 7582 | 272   | 16   | 230 969 7 | 108   | 95   |
| 230 6749 | 140   | 959  | 230 7589 | 272   | 16   | 230 969 8 | 108   | 96   |
| 230 6750 | 140   | 960  | 230 7592 | 272   | 26   | 230 974 3 | 184   | 2    |
| 230 6751 | 140   | 961  | 230 7597 | 272   | 31   | 230 974 6 | 185   | 70   |
| 230 6752 | 140   | 962  | 230 7600 | 117   | 48   | 230 975 9 | 132   | 2    |
| 230 6753 | 140   | 963  | 230 7600 | 122   | 48   | 230 977 6 | 184   | 16   |
| 230 6754 | 140   | 964  | 230 7623 | 94    | 40   | 230 977 7 | 184   | 24   |
| 230 6755 | 140   | 965  | 230 7623 | 96    | 65   | 230 977 9 | 184   | 35   |
| 230 6756 | 140   | 966  | 230 7627 | 94    | 39   | 230 977 9 | 184   | 35   |
| 230 6797 | 253   | 2    | 230 7627 | 96    | 64   | 230 978 0 | 185   | 43   |
| 230 6798 | 269   | 6    | 230 7628 | 93    | 15   | 230 978 1 | 185   | 45   |
| 230 6803 | 253   | 1    | 230 7628 | 96    | 43   | 230 978 3 | 185   | 52   |
| 230 6850 | 132   | 29   | 230 7630 | 96    | 54   | 230 978 4 | 185   | 53   |
| 230 6852 | 132   | 31   | 230 7631 | 96    | 55   | 230 978 5 | 185   | 54   |
| 230 6856 | 132   | 35   | 230 7632 | 96    | 56   | 230 978 6 | 185   | 55   |
| 230 6864 | 207   | 5    | 230 7633 | 96    | 57   | 230 979 0 | 185   | 950  |
| 230 6864 | 208   | 10   | 230 7635 | 96    | 61   | 230 979 1 | 185   | 951  |
| 230 6908 | 226   | 2    | 230 7636 | 96    | 60   | 230 979 2 | 185   | 952  |
| 230 6919 | 221   | 1    | 230 7637 | 95    | 35   | 230 980 9 | 308   | 12   |
| 230 6921 | 261   | 1    | 230 7638 | 95    | 36   | 230 980 9 | 326   | 66   |
| 230 6932 | 134   | 29   | 230 7639 | 93    | 23   | 231 008 0 | 243   | 26   |
| 230 6938 | 139   | 56   | 230 7639 | 95    | 39   | 231 008 0 | 246   | 37   |
| 230 6939 | 140   | 967  | 230 7640 | 95    | 40   | 231 057 5 | 141   | 4    |
| 230 6940 | 140   | 968  | 230 7641 | 96    | 52   | 231 057 6 | 141   | 10   |
| 230 6941 | 140   | 969  | 230 7702 | 102   | 31   | 231 057 8 | 141   | 8    |
| 230 6942 | 140   | 970  | 230 7739 | 125   | 17   | 231 057 9 | 141   | 9    |
| 230 6943 | 140   | 971  | 230 7743 | 125   | 16   | 231 058 2 | 141   | 12   |
| 230 6944 | 140   | 972  | 230 7777 | 110   | 46   | 231 088 8 | 194   | 12   |
| 230 6945 | 140   | 973  | 230 7909 | 273   | 44   | 231 091 8 | 239   | 15   |
| 230 6946 | 140   | 974  | 230 7910 | 273   | 45   | 231 091 8 | 242   | 56   |
| 230 6947 | 140   | 975  | 230 7911 | 273   | 42   | 231 091 8 | 243   | 23   |
| 230 6948 | 140   | 976  | 230 7912 | 273   | 43   | 231 091 8 | 246   | 27   |
| 230 6949 | 140   | 977  | 230 8040 | 253   | 3    | 231 095 1 | 139   | 38   |
| 230 6950 | 140   | 978  | 230 8077 | 182   | 46   | 231 095 6 | 268   | 24   |
| 230 6951 | 140   | 979  | 230 8077 | 187   | 57   | 231 095 9 | 265   | 15   |
| 230 6952 | 140   | 980  | 230 8112 | 105   | 3    | 231 098 9 | 177   | 10   |
| 230 6953 | 140   | 981  | 230 8168 | 263   | 1    | 231 099 4 | 177   | 2    |
| 230 6954 | 140   | 982  | 230 8169 | 263   | 2    | 231 099 6 | 177   | 8    |
| 230 6955 | 140   | 983  | 230 9176 | 125   | 5    | 231 099 8 | 178   | 29   |
| 230 6957 | 223   | 2    | 230 9178 | 125   | 10   | 231 100 0 | 177   | 18   |
| 230 6958 | 223   | 1    | 230 9180 | 125   | 6    | 231 100 0 | 180   | 62   |
|          |       |      | 230 9181 | 125   | 13   | 231 100 6 | 177   | 27   |
|          |       |      | 230 9183 | 125   | 7    | 231 100 7 | 178   | 28   |

| TEILE-NR | SEITE | BILD | TEILE-NR | SEITE | BILD | TEILE-NR | SEITE | BILD |
|----------|-------|------|----------|-------|------|----------|-------|------|
| 231 1051 | 205   | 1    | 231 1230 | 178   | 955  | 231 2039 | 297   | 179  |
| 231 1114 | 274   | 18   | 231 1230 | 180   | 951  | 231 2040 | 292   | 196  |
| 231 1118 | 151   | 24   | 231 1231 | 178   | 956  | 231 2108 | 303   | 33   |
| 231 1120 | 153   | 160  | 231 1231 | 180   | 952  | 231 2111 | 311   | 19   |
| 231 1121 | 153   | 125  | 231 1232 | 178   | 957  | 231 2111 | 312   | 19   |
| 231 1124 | 151   | 4    | 231 1232 | 180   | 953  | 231 2112 | 311   | 6    |
| 231 1127 | 152   | 43   | 231 1233 | 178   | 958  | 231 2112 | 312   | 6    |
| 231 1128 | 152   | 44   | 231 1233 | 180   | 954  | 231 2113 | 311   | 3    |
| 231 1129 | 152   | 76   | 231 1234 | 178   | 959  | 231 2113 | 312   | 3    |
| 231 1131 | 152   | 52   | 231 1234 | 180   | 955  | 231 2166 | 291   | 106  |
| 231 1134 | 152   | 77   | 231 1251 | 184   | 33   | 231 2166 | 296   | 106  |
| 231 1139 | 152   | 32   | 231 1262 | 185   | 62   | 231 2185 | 292   | 134  |
| 231 1140 | 152   | 21   | 231 1284 | 117   | 49   | 231 2185 | 297   | 134  |
| 231 1141 | 151   | 12   | 231 1284 | 122   | 49   | 231 2186 | 292   | 137  |
| 231 1144 | 152   | 29   | 231 1292 | 270   | 43   | 231 2186 | 297   | 137  |
| 231 1147 | 152   | 24   | 231 1294 | 270   | 41   | 231 2241 | 308   | 4    |
| 231 1148 | 151   | 11   | 231 1319 | 94    | 38   | 231 2246 | 308   | 6    |
| 231 1149 | 151   | 27   | 231 1380 | 133   | 26   | 231 2286 | 243   | 5    |
| 231 1151 | 151   | 9    | 231 1404 | 133   | 25   | 231 2286 | 245   | 5    |
| 231 1153 | 152   | 66   | 231 1411 | 194   | 8    | 231 2296 | 311   | 5    |
| 231 1154 | 151   | 8    | 231 1488 | 189   | 9    | 231 2296 | 312   | 5    |
| 231 1155 | 152   | 25   | 231 1490 | 211   | 5    | 231 2565 | 94    | 37   |
| 231 1156 | 152   | 46   | 231 1492 | 249   | 6    | 231 2574 | 94    | 35   |
| 231 1157 | 152   | 27   | 231 1507 | 110   | 48   | 231 2598 | 99    | 33   |
| 231 1159 | 152   | 61   | 231 1552 | 190   | 32   | 231 2588 | 101   | 33   |
| 231 1160 | 152   | 20   | 231 1552 | 192   | 32   | 231 2618 | 194   | 11   |
| 231 1161 | 152   | 64   | 231 1568 | 114   | 18   | 231 2619 | 194   | 13   |
| 231 1162 | 152   | 63   | 231 1569 | 114   | 13   | 231 2681 | 205   | 4    |
| 231 1163 | 152   | 41   | 231 1632 | 212   | 43   | 231 2766 | 321   | 16   |
| 231 1164 | 151   | 22   | 231 1637 | 161   | 4    | 231 2767 | 321   | 4    |
| 231 1165 | 153   | 165  | 231 1637 | 162   | 4    | 231 2770 | 321   | 1    |
| 231 1166 | 151   | 19   | 231 1637 | 163   | 4    | 231 2779 | 321   | 6    |
| 231 1167 | 152   | 58   | 231 1637 | 164   | 4    | 231 2781 | 321   | 2    |
| 231 1168 | 152   | 57   | 231 1673 | 119   | 52   | 231 2792 | 322   | 51   |
| 231 1170 | 152   | 70   | 231 1679 | 119   | 53   | 231 2799 | 321   | 3    |
| 231 1171 | 151   | 25   | 231 1681 | 265   | 3    | 231 2828 | 321   | 23   |
| 231 1172 | 153   | 162  | 231 1684 | 114   | 34   | 231 3037 | 288   | 5    |
| 231 1173 | 151   | 26   | 231 1696 | 194   | 5    | 231 3039 | 281   | 21   |
| 231 1174 | 152   | 79   | 231 1716 | 177   | 21   | 231 3039 | 286   | 21   |
| 231 1177 | 152   | 80   | 231 1721 | 177   | 7    | 231 3039 | 288   | 1    |
| 231 1178 | 152   | 65   | 231 1730 | 274   | 19   | 231 3111 | 279   | 4    |
| 231 1179 | 152   | 74   | 231 1752 | 119   | 54   | 231 3118 | 280   | 71   |
| 231 1180 | 151   | 14   | 231 1755 | 119   | 58   | 231 3119 | 279   | 3    |
| 231 1182 | 153   | 166  | 231 1756 | 119   | 60   | 231 3122 | 279   | 6    |
| 231 1182 | 154   | 170  | 231 1762 | 119   | 62   | 231 3126 | 279   | 7    |
| 231 1183 | 152   | 78   | 231 1763 | 119   | 65   | 231 3139 | 279   | 31   |
| 231 1184 | 152   | 42   | 231 1764 | 119   | 63   | 231 3151 | 286   | 25   |
| 231 1186 | 154   | 180  | 231 1766 | 127   | 50   | 231 3157 | 286   | 34   |
| 231 1187 | 154   | 182  | 231 1778 | 95    | 27   | 231 3179 | 287   | 44   |
| 231 1188 | 154   | 183  | 231 1920 | 323   | 31   | 231 3372 | 321   | 36   |
| 231 1190 | 152   | 40   | 231 1920 | 326   | 47   | 231 3377 | 321   | 37   |
| 231 1193 | 152   | 62   | 231 1920 | 327   | 24   | 231 3385 | 322   | 39   |
| 231 1194 | 152   | 29   | 231 1975 | 293   | 273  | 231 3396 | 330   | 29   |
| 231 1195 | 151   | 23   | 231 1980 | 303   | 15   | 231 3396 | 334   | 29   |
| 231 1196 | 151   | 10   | 231 1980 | 305   | 15   | 231 3397 | 333   | 19   |
| 231 1197 | 152   | 47   | 231 1981 | 303   | 14   | 231 3419 | 96    | 53   |
| 231 1198 | 152   | 48   | 231 1981 | 305   | 14   | 231 3420 | 95    | 37   |
| 231 1201 | 153   | 88   | 231 1984 | 292   | 178  | 231 3564 | 117   | 67   |
| 231 1202 | 153   | 164  | 231 1985 | 293   | 271  | 231 3564 | 122   | 67   |
| 231 1203 | 152   | 56   | 231 1986 | 293   | 272  | 231 3568 | 118   | 69   |
| 231 1229 | 178   | 954  | 231 1987 | 293   | 274  | 231 3568 | 122   | 69   |
| 231 1229 | 180   | 950  | 231 2039 | 292   | 179  | 231 3631 | 118   | 71   |

| TEILE-NR | SEITE | BILD | TEILE-NR | SEITE | BILD | TEILE-NR | SEITE | BILD |
|----------|-------|------|----------|-------|------|----------|-------|------|
| 231 3631 | 122   | 71   | 231 5173 | 185   | 97   | 231 6498 | 115   | 1    |
| 231 3685 | 124   | 23   | 231 5174 | 185   | 66   | 231 6746 | 93    | 26   |
| 231 3803 | 271   | 46   | 231 5175 | 185   | 64   | 231 6746 | 96    | 47   |
| 231 3810 | 212   | 50   | 231 5176 | 185   | 69   | 231 6768 | 93    | 2    |
| 231 3813 | 337   | 4    | 231 5249 | 235   | 6    | 231 6769 | 95    | 33   |
| 231 3817 | 337   | 3    | 231 5250 | 235   | 7    | 231 6787 | 153   | 153  |
| 231 3855 | 155   | 6    | 231 5251 | 235   | 8    | 231 6796 | 118   | 73   |
| 231 3858 | 155   | 12   | 231 5252 | 235   | 9    | 231 6796 | 123   | 73   |
| 231 3884 | 263   | 10   | 231 5254 | 235   | 10   | 231 6926 | 111   | 108  |
| 231 3903 | 155   | 1    | 231 5262 | 169   | 40   | 231 6972 | 118   | 77   |
| 231 3904 | 155   | 2    | 231 5361 | 183   | 10   | 231 6972 | 123   | 77   |
| 231 3911 | 205   | 3    | 231 5361 | 186   | 53   | 231 6983 | 128   | 6    |
| 231 4169 | 174   | 29   | 231 5400 | 138   | 4    | 231 6994 | 130   | 13   |
| 231 4169 | 175   | 26   | 231 5416 | 141   | 2    | 231 7206 | 301   | 17   |
| 231 4547 | 241   | 41   | 231 5417 | 141   | 3    | 231 8008 | 256   | 1    |
| 231 4547 | 243   | 10   | 231 5418 | 141   | 5    | 231 8190 | 185   | 63   |
| 231 4603 | 185   | 56   | 231 5419 | 141   | 6    | 231 8528 | 326   | 51   |
| 231 4627 | 94    | 41   | 231 5420 | 141   | 7    | 231 8528 | 328   | 37   |
| 231 4627 | 96    | 67   | 231 5423 | 142   | 22   | 231 8930 | 323   | 35   |
| 231 4628 | 94    | 42   | 231 5423 | 143   | 22   | 231 9173 | 311   | 30   |
| 231 4628 | 96    | 68   | 231 5424 | 142   | 23   | 231 9173 | 312   | 30   |
| 231 4739 | 292   | 141  | 231 5424 | 143   | 23   | 231 9175 | 311   | 31   |
| 231 4739 | 297   | 141  | 231 5425 | 142   | 24   | 231 9175 | 312   | 31   |
| 231 4745 | 308   | 5    | 231 5425 | 143   | 24   | 231 9363 | 281   | 9    |
| 231 4780 | 292   | 189  | 231 5434 | 240   | 2    | 231 9363 | 286   | 9    |
| 231 4780 | 297   | 189  | 231 5435 | 241   | 7    | 231 9364 | 281   | 7    |
| 231 4848 | 308   | 10   | 231 5451 | 199   | 16   | 231 9364 | 286   | 7    |
| 231 4868 | 301   | 18   | 231 5451 | 200   | 14   | 231 9366 | 281   | 6    |
| 231 4870 | 301   | 19   | 231 5451 | 202   | 12   | 231 9366 | 286   | 6    |
| 231 4872 | 292   | 194  | 231 5525 | 207   | 11   | 231 9508 | 199   | 20   |
| 231 4872 | 297   | 194  | 231 5526 | 207   | 16   | 231 9524 | 138   | 6    |
| 231 4874 | 292   | 193  | 231 5529 | 208   | 8    | 231 9525 | 139   | 55   |
| 231 4874 | 297   | 193  | 231 5545 | 207   | 10   | 231 9546 | 266   | 955  |
| 231 5139 | 184   | 8    | 231 5612 | 132   | 9    | 231 9546 | 268   | 955  |
| 231 5140 | 184   | 9    | 231 5688 | 153   | 156  | 231 9547 | 266   | 956  |
| 231 5142 | 184   | 12   | 231 5697 | 191   | 50   | 231 9547 | 268   | 956  |
| 231 5143 | 184   | 15   | 231 5697 | 192   | 50   | 231 9548 | 266   | 957  |
| 231 5144 | 184   | 17   | 231 5752 | 265   | 14   | 231 9548 | 268   | 957  |
| 231 5145 | 184   | 18   | 231 5752 | 267   | 23   | 231 9551 | 189   | 6    |
| 231 5146 | 184   | 19   | 231 5857 | 199   | 4    | 231 9677 | 211   | 11   |
| 231 5147 | 184   | 20   | 231 5897 | 197   | 4    | 231 9689 | 161   | 2    |
| 231 5148 | 184   | 21   | 231 5923 | 148   | 30   | 231 9689 | 162   | 2    |
| 231 5149 | 184   | 23   | 231 5923 | 149   | 30   | 231 9689 | 163   | 1    |
| 231 5150 | 184   | 26   | 231 5925 | 148   | 31   | 231 9689 | 164   | 1    |
| 231 5151 | 184   | 27   | 231 5925 | 149   | 31   | 231 9690 | 161   | 1    |
| 231 5152 | 184   | 28   | 231 5962 | 148   | 5    | 231 9690 | 162   | 1    |
| 231 5153 | 184   | 29   | 231 5962 | 149   | 5    | 231 9690 | 163   | 2    |
| 231 5154 | 184   | 30   | 231 5967 | 197   | 14   | 231 9690 | 164   | 2    |
| 231 5155 | 184   | 31   | 231 5967 | 198   | 10   | 231 9713 | 194   | 1    |
| 231 5156 | 185   | 33   | 231 5968 | 197   | 15   | 231 9764 | 291   | 74   |
| 231 5157 | 184   | 34   | 231 5968 | 198   | 11   | 231 9764 | 296   | 74   |
| 231 5158 | 185   | 26   | 231 5980 | 138   | 5    | 231 9777 | 281   | 2    |
| 231 5159 | 185   | 38   | 231 5981 | 138   | 7    | 231 9777 | 286   | 2    |
| 231 5160 | 185   | 39   | 231 5982 | 151   | 3    | 231 9833 | 332   | 91   |
| 231 5161 | 185   | 40   | 231 5984 | 151   | 2    | 231 9833 | 334   | 91   |
| 231 5162 | 185   | 41   | 231 6013 | 212   | 39   | 231 9834 | 334   | 94   |
| 231 5164 | 185   | 48   | 231 6032 | 199   | 21   | 231 9838 | 332   | 99   |
| 231 5165 | 185   | 49   | 231 6043 | 153   | 102  | 231 9838 | 334   | 93   |
| 231 5168 | 185   | 57   | 231 6048 | 189   | 5    | 231 9839 | 332   | 96   |
| 231 5169 | 185   | 64   | 231 6231 | 138   | 1    | 231 9839 | 334   | 99   |
| 231 5170 | 185   | 95   | 231 6441 | 155   | 12   | 231 9844 | 331   | 55   |
| 231 5172 | 185   | 96   | 231 6469 | 155   | 16   | 231 9844 | 334   | 55   |

| TEILE-NR | SEITE | BILD | TEILE-NR | SEITE | BILD | TEILE-NR  | SEITE | BILD |
|----------|-------|------|----------|-------|------|-----------|-------|------|
| 231 9876 | 331   | 57   | 232 1225 | 223   | 22   | 232 466 0 | 179   | 28   |
| 231 9876 | 334   | 57   | 232 1227 | 225   | 23   | 232 466 2 | 180   | 71   |
| 231 9885 | 331   | 49   | 232 1228 | 223   | 24   | 232 466 3 | 238   | 8    |
| 231 9885 | 334   | 49   | 232 1229 | 223   | 26   | 232 469 1 | 179   | 39   |
| 231 9905 | 332   | 111  | 232 1229 | 225   | 27   | 232 479 7 | 179   | 4    |
| 231 9905 | 335   | 111  | 232 1230 | 223   | 27   | 232 482 1 | 223   | 11   |
| 231 9907 | 332   | 112  | 232 1232 | 223   | 29   | 232 482 2 | 223   | 12   |
| 231 9907 | 335   | 112  | 232 1305 | 281   | 3    | 232 491 2 | 179   | 33   |
| 231 9909 | 331   | 56   | 232 1305 | 286   | 3    | 232 491 3 | 179   | 1    |
| 231 9909 | 334   | 56   | 232 1415 | 119   | 74   | 232 506 2 | 119   | 90   |
| 231 9922 | 330   | 19   | 232 1417 | 119   | 950  | 232 541 6 | 102   | 14   |
| 231 9925 | 331   | 54   | 232 1504 | 102   | 17   | 232 548 1 | 248   | 25   |
| 231 9925 | 334   | 54   | 232 1504 | 271   | 51   | 232 555 1 | 153   | 110  |
| 231 9939 | 331   | 63   | 232 1571 | 119   | 75   | 232 556 5 | 240   | 1    |
| 231 9939 | 334   | 63   | 232 1627 | 119   | 76   | 232 556 8 | 132   | 22   |
| 231 9951 | 313   | 27   | 232 1955 | 182   | 44   | 232 558 8 | 241   | 31   |
| 231 9953 | 313   | 28   | 232 1955 | 183   | 1    | 232 559 6 | 161   | 36   |
| 232 0095 | 293   | 293  | 232 1955 | 186   | 55   | 232 559 6 | 162   | 36   |
| 232 0095 | 298   | 306  | 232 1958 | 241   | 2    | 232 559 6 | 164   | 19   |
| 232 0096 | 293   | 294  | 232 1971 | 137   | 11   | 232 563 5 | 197   | 1    |
| 232 0096 | 298   | 307  | 232 1974 | 137   | 8    | 232 564 7 | 168   | 4    |
| 232 0098 | 293   | 288  | 232 1981 | 153   | 108  | 232 564 9 | 168   | 3    |
| 232 0098 | 298   | 295  | 232 1992 | 182   | 47   | 232 566 1 | 138   | 2    |
| 232 0445 | 304   | 42   | 232 1992 | 183   | 21   | 232 569 0 | 189   | 1    |
| 232 0445 | 306   | 46   | 232 1992 | 187   | 59   | 232 572 9 | 197   | 23   |
| 232 0492 | 291   | 93   | 232 2287 | 311   | 33   | 232 573 7 | 153   | 161  |
| 232 0492 | 296   | 93   | 232 2287 | 312   | 33   | 232 576 8 | 210   | 2    |
| 232 0760 | 97    | 4    | 232 2538 | 278   | 80   | 232 576 9 | 210   | 1    |
| 232 0760 | 98    | 4    | 232 2599 | 154   | 951  | 232 579 0 | 153   | 111  |
| 232 0779 | 93    | 5    | 232 2600 | 154   | 950  | 232 579 1 | 153   | 113  |
| 232 0780 | 93    | 7    | 232 2665 | 160   | 7    | 232 579 2 | 153   | 114  |
| 232 0826 | 162   | 13   | 232 2673 | 207   | 29   | 232 579 3 | 153   | 115  |
| 232 0830 | 183   | 3    | 232 2673 | 208   | 9    | 232 579 4 | 153   | 116  |
| 232 0840 | 183   | 5    | 232 2921 | 197   | 5    | 232 579 5 | 153   | 117  |
| 232 0876 | 161   | 6    | 232 2921 | 199   | 5    | 232 579 6 | 153   | 118  |
| 232 0876 | 162   | 6    | 232 2941 | 96    | 48   | 232 579 7 | 102   | 26   |
| 232 0877 | 161   | 12   | 232 2943 | 96    | 49   | 232 579 8 | 102   | 27   |
| 232 0877 | 162   | 12   | 232 2947 | 93    | 27   | 232 587 0 | 121   | 59   |
| 232 0881 | 241   | 27   | 232 2983 | 230   | 6    | 232 587 2 | 120   | 2    |
| 232 0882 | 241   | 26   | 232 2986 | 234   | 41   | 232 587 7 | 161   | 39   |
| 232 0884 | 204   | 2    | 232 3005 | 232   | 83   | 232 587 7 | 162   | 39   |
| 232 0892 | 161   | 27   | 232 3006 | 232   | 84   | 232 587 7 | 163   | 11   |
| 232 0892 | 162   | 27   | 232 3037 | 254   | 7    | 232 587 7 | 164   | 11   |
| 232 0892 | 163   | 12   | 232 3037 | 255   | 7    | 232 587 7 | 331   | 83   |
| 232 0892 | 164   | 12   | 232 3081 | 231   | 54   | 232 587 7 | 334   | 83   |
| 232 0894 | 204   | 1    | 232 3082 | 231   | 51   | 232 587 9 | 156   | 38   |
| 232 0896 | 204   | 12   | 232 3083 | 231   | 52   | 232 588 4 | 156   | 36   |
| 232 1004 | 241   | 3    | 232 3210 | 254   | 8    | 232 588 7 | 156   | 35   |
| 232 1011 | 241   | 29   | 232 3210 | 255   | 8    | 232 598 1 | 199   | 24   |
| 232 1012 | 241   | 30   | 232 3218 | 254   | 10   | 232 598 4 | 199   | 1    |
| 232 1015 | 161   | 38   | 232 3218 | 255   | 10   | 232 605 1 | 199   | 15   |
| 232 1015 | 162   | 38   | 232 3719 | 299   | 44   | 232 605 2 | 132   | 26   |
| 232 1015 | 163   | 18   | 232 3719 | 300   | 44   | 232 607 5 | 148   | 14   |
| 232 1015 | 164   | 18   | 232 3749 | 278   | 79   | 232 607 7 | 148   | 6    |
| 232 1018 | 188   | 12   | 232 4196 | 258   | 17   | 232 607 7 | 149   | 6    |
| 232 1018 | 189   | 10   | 232 4347 | 332   | 98   | 232 608 1 | 148   | 33   |
| 232 1074 | 302   | 22   | 232 4372 | 321   | 15   | 232 608 2 | 148   | 32   |
| 232 1075 | 302   | 23   | 232 4386 | 322   | 38   | 232 608 7 | 160   | 4    |
| 232 1187 | 241   | 39   | 232 4393 | 321   | 8    | 232 608 8 | 160   | 5    |
| 232 1187 | 243   | 8    | 232 4654 | 179   | 14   | 232 608 9 | 160   | 11   |
| 232 1190 | 223   | 21   | 232 4657 | 180   | 63   | 232 609 0 | 263   | 16   |
| 232 1213 | 334   | 102  | 232 4658 | 179   | 41   | 232 679 0 | 291   | 120  |

| TEILF-NR | SEITE | BILD | TEILE-NR | SEITE | BILD | TEILE-NR | SEITE | BILD |
|----------|-------|------|----------|-------|------|----------|-------|------|
| 232 6790 | 296   | 120  | 233 0304 | 232   | 73   | 233 1567 | 298   | 308  |
| 232 7268 | 264   | 6    | 233 0304 | 234   | 42   | 233 1817 | 292   | 210  |
| 232 7271 | 264   | 1    | 233 0305 | 230   | 74   | 233 1817 | 297   | 210  |
| 232 7346 | 260   | 1    | 233 0305 | 232   | 74   | 233 1959 | 293   | 291  |
| 232 7947 | 238   | 1    | 233 0305 | 234   | 43   | 233 1959 | 297   | 286  |
| 232 7948 | 238   | 2    | 233 0369 | 153   | 152  | 233 2036 | 302   | 3    |
| 232 7949 | 238   | 3    | 233 0371 | 153   | 145  | 233 2038 | 302   | 11   |
| 232 7950 | 238   | 4    | 233 0372 | 154   | 172  | 233 2083 | 302   | 4    |
| 232 7950 | 239   | 4    | 233 0763 | 212   | 70   | 233 2188 | 221   | 21   |
| 232 7951 | 238   | 5    | 233 0764 | 207   | 30   | 233 2189 | 220   | 22   |
| 232 7952 | 238   | 6    | 233 0768 | 204   | 17   | 233 2189 | 221   | 22   |
| 232 7952 | 239   | 6    | 233 0793 | 97    | 20   | 233 2190 | 220   | 24   |
| 232 9192 | 332   | 54   | 233 0793 | 99    | 70   | 233 2190 | 221   | 24   |
| 232 9194 | 335   | 122  | 233 0834 | 169   | 34   | 233 2192 | 221   | 25   |
| 232 9208 | 331   | 68   | 233 0834 | 171   | 34   | 233 2194 | 227   | 35   |
| 232 9208 | 334   | 68   | 233 0834 | 175   | 39   | 233 2195 | 227   | 42   |
| 232 9211 | 331   | 69   | 233 0836 | 170   | 950  | 233 2196 | 227   | 43   |
| 232 9211 | 334   | 69   | 233 0836 | 172   | 950  | 233 2197 | 227   | 34   |
| 232 9242 | 330   | 23   | 233 0836 | 176   | 950  | 233 2199 | 227   | 31   |
| 232 9242 | 333   | 23   | 233 0837 | 170   | 951  | 233 2200 | 227   | 32   |
| 232 9247 | 330   | 24   | 233 0837 | 172   | 951  | 233 2204 | 227   | 33   |
| 232 9243 | 333   | 24   | 233 0837 | 176   | 951  | 233 2205 | 227   | 37   |
| 232 9244 | 331   | 64   | 233 0857 | 258   | 2    | 233 2206 | 227   | 36   |
| 232 9245 | 331   | 65   | 233 0858 | 258   | 1    | 233 2386 | 188   | 15   |
| 232 9248 | 271   | 48   | 233 0863 | 258   | 8    | 233 2429 | 166   | 1    |
| 232 9248 | 273   | 53   | 233 1059 | 220   | 10   | 233 2431 | 166   | 12   |
| 232 9252 | 331   | 74   | 233 1059 | 221   | 10   | 233 2431 | 167   | 14   |
| 232 9260 | 332   | 116  | 233 1059 | 222   | 10   | 233 2477 | 163   | 3    |
| 232 9260 | 335   | 116  | 233 1121 | 254   | 1    | 233 2477 | 164   | 3    |
| 232 9262 | 332   | 117  | 233 1122 | 254   | 2    | 233 2555 | 194   | 19   |
| 232 9262 | 335   | 117  | 233 1122 | 255   | 2    | 233 2628 | 195   | 2    |
| 232 9263 | 334   | 76   | 233 1124 | 254   | 4    | 233 2632 | 195   | 1    |
| 232 9536 | 118   | 79   | 233 1124 | 255   | 4    | 233 2632 | 196   | 1    |
| 232 9536 | 123   | 79   | 233 1126 | 254   | 5    | 233 2644 | 161   | 44   |
| 232 9538 | 118   | 80   | 233 1126 | 255   | 5    | 233 2644 | 162   | 44   |
| 232 9538 | 123   | 80   | 233 1127 | 254   | 6    | 233 2644 | 163   | 19   |
| 232 9540 | 119   | 81   | 233 1127 | 255   | 6    | 233 2644 | 165   | 36   |
| 232 9547 | 163   | 5    | 233 1128 | 254   | 3    | 233 2648 | 161   | 43   |
| 232 9617 | 102   | 6    | 233 1128 | 255   | 3    | 233 2648 | 162   | 43   |
| 232 9620 | 134   | 68   | 233 1132 | 232   | 81   | 233 2674 | 160   | 10   |
| 232 9645 | 114   | 11   | 233 1133 | 232   | 82   | 233 2675 | 160   | 13   |
| 232 9646 | 114   | 8    | 233 1138 | 232   | 88   | 233 2741 | 121   | 61   |
| 232 9647 | 114   | 10   | 233 1139 | 232   | 89   | 233 2751 | 121   | 60   |
| 232 9648 | 114   | 12   | 233 1140 | 232   | 86   | 233 2754 | 163   | 6    |
| 232 9654 | 108   | 101  | 233 1141 | 232   | 87   | 233 2755 | 163   | 7    |
| 232 9664 | 114   | 29   | 233 1263 | 210   | 7    | 233 2771 | 159   | 2    |
| 232 9665 | 114   | 31   | 233 1264 | 213   | 14   | 233 2798 | 99    | 57   |
| 232 9913 | 116   | 58   | 233 1281 | 203   | 9    | 233 2798 | 101   | 57   |
| 232 9913 | 121   | 58   | 233 1282 | 263   | 11   | 233 2820 | 302   | 6    |
| 233 0166 | 99    | 59   | 233 1289 | 97    | 19   | 233 2876 | 213   | 12   |
| 233 0166 | 101   | 59   | 233 1294 | 100   | 71   | 233 2876 | 215   | 12   |
| 233 0170 | 123   | 84   | 233 1300 | 215   | 33   | 233 2893 | 144   | 2    |
| 233 0180 | 99    | 60   | 233 1300 | 217   | 1    | 233 2893 | 146   | 2    |
| 233 0180 | 101   | 60   | 233 1345 | 291   | 112  | 233 2895 | 144   | 1    |
| 233 0268 | 97    | 18   | 233 1345 | 296   | 112  | 233 2895 | 146   | 1    |
| 233 0268 | 98    | 18   | 233 1376 | 213   | 27   | 233 2899 | 214   | 81   |
| 233 0268 | 99    | 68   | 233 1376 | 215   | 27   | 233 2900 | 203   | 3    |
| 233 0268 | 101   | 68   | 233 1394 | 211   | 18   | 233 2900 | 214   | 82   |
| 233 0271 | 99    | 58   | 233 1395 | 211   | 27   | 233 2900 | 216   | 63   |
| 233 0283 | 195   | 14   | 233 1564 | 292   | 206  | 233 2900 | 217   | 2    |
| 233 0283 | 196   | 14   | 233 1564 | 297   | 206  | 233 2900 | 219   | 9    |
| 233 0304 | 230   | 73   | 233 1567 | 293   | 295  | 233 2954 | 214   | 83   |



| TEILE-NR | SEITE | BILD | TEILE-NR | SEITE | BILD | TEILE-NR | SEITE | BILD |
|----------|-------|------|----------|-------|------|----------|-------|------|
| 233 2954 | 217   | 6    | 233 3817 | 159   | 9    | 233 5361 | 221   | 15   |
| 233 2955 | 214   | 84   | 233 3818 | 159   | 10   | 233 5361 | 222   | 15   |
| 233 2955 | 217   | 7    | 233 3862 | 276   | 89   | 233 5398 | 157   | 1    |
| 233 2956 | 214   | 85   | 233 3865 | 278   | 78   | 233 5399 | 157   | 2    |
| 233 2956 | 217   | 8    | 233 3869 | 276   | 71   | 233 5403 | 224   | 12   |
| 233 2958 | 203   | 4    | 233 3955 | 134   | 32   | 233 5406 | 224   | 2    |
| 233 2958 | 217   | 10   | 233 3957 | 136   | 21   | 233 5413 | 258   | 26   |
| 233 2981 | 157   | 4    | 233 3995 | 114   | 32   | 233 5414 | 258   | 27   |
| 233 2983 | 157   | 9    | 233 4004 | 111   | 102  | 233 5812 | 214   | 75   |
| 233 2988 | 183   | 2    | 233 4005 | 111   | 103  | 233 5812 | 216   | 75   |
| 233 2995 | 213   | 28   | 233 4006 | 110   | 43   | 233 5822 | 212   | 68   |
| 233 3053 | 304   | 41   | 233 4037 | 167   | 1    | 233 5861 | 179   | 15   |
| 233 3053 | 306   | 47   | 233 4039 | 213   | 1    | 233 5869 | 179   | 11   |
| 233 3054 | 303   | 35   | 233 4039 | 215   | 1    | 233 5921 | 179   | 29   |
| 233 3054 | 305   | 35   | 233 4058 | 211   | 24   | 233 5926 | 187   | 97   |
| 233 3056 | 304   | 44   | 233 4210 | 191   | 82   | 233 5927 | 182   | 51   |
| 233 3056 | 306   | 48   | 233 4210 | 192   | 63   | 233 5932 | 111   | 117  |
| 233 3194 | 254   | 9    | 233 4251 | 258   | 9    | 233 5947 | 146   | 3    |
| 233 3194 | 255   | 9    | 233 4403 | 187   | 58   | 233 5947 | 147   | 3    |
| 233 3215 | 211   | 35   | 233 4428 | 168   | 5    | 233 5948 | 146   | 4    |
| 233 3216 | 211   | 26   | 233 4457 | 283   | 40   | 233 5948 | 147   | 4    |
| 233 3239 | 201   | 3    | 233 4457 | 284   | 25   | 233 5951 | 111   | 116  |
| 233 3242 | 201   | 4    | 233 4468 | 293   | 290  | 233 6405 | 111   | 114  |
| 233 3248 | 201   | 9    | 233 4503 | 193   | 67   | 233 7887 | 248   | 45   |
| 233 3263 | 334   | 64   | 233 4503 | 191   | 80   | 233 7892 | 208   | 3    |
| 233 3279 | 334   | 97   | 233 4504 | 193   | 65   | 233 7893 | 209   | 32   |
| 233 3280 | 334   | 84   | 233 4504 | 191   | 81   | 233 8048 | 242   | 43   |
| 233 3286 | 258   | 7    | 233 4506 | 254   | 11   | 233 8048 | 243   | 15   |
| 233 3404 | 111   | 91   | 233 4506 | 255   | 11   | 233 8049 | 242   | 55   |
| 233 3405 | 111   | 81   | 233 4523 | 230   | 77   | 233 8052 | 242   | 49   |
| 233 3406 | 114   | 33   | 233 4546 | 190   | 3    | 233 8053 | 242   | 50   |
| 233 3413 | 111   | 104  | 233 4548 | 190   | 1    | 233 8053 | 243   | 2    |
| 233 3425 | 111   | 89   | 233 4549 | 190   | 2    | 233 8053 | 245   | 2    |
| 233 3433 | 242   | 46   | 233 4603 | 181   | 13   | 233 8054 | 242   | 59   |
| 233 3437 | 242   | 53   | 233 4604 | 181   | 14   | 233 8054 | 243   | 3    |
| 233 3437 | 242   | 58   | 233 4605 | 181   | 19   | 233 8055 | 242   | 60   |
| 233 3440 | 241   | 34   | 233 4614 | 185   | 77   | 233 8055 | 243   | 4    |
| 233 3444 | 242   | 57   | 233 4616 | 185   | 98   | 233 8056 | 242   | 61   |
| 233 3444 | 243   | 24   | 233 4617 | 185   | 99   | 233 8083 | 202   | 5    |
| 233 3444 | 246   | 35   | 233 4619 | 185   | 76   | 233 8139 | 157   | 11   |
| 233 3446 | 241   | 36   | 233 4655 | 225   | 32   | 233 8140 | 157   | 12   |
| 233 3447 | 241   | 37   | 233 4686 | 118   | 91   | 233 8141 | 157   | 13   |
| 233 3447 | 243   | 6    | 233 4686 | 123   | 91   | 233 8142 | 157   | 14   |
| 233 3447 | 245   | 6    | 233 4688 | 119   | 92   | 233 8143 | 157   | 15   |
| 233 3448 | 241   | 42   | 233 4695 | 135   | 77   | 233 8144 | 158   | 39   |
| 233 3448 | 243   | 11   | 233 4848 | 211   | 6    | 233 8145 | 158   | 40   |
| 233 3448 | 245   | 11   | 233 4897 | 286   | 11   | 233 8244 | 211   | 13   |
| 233 3475 | 225   | 31   | 233 4899 | 286   | 12   | 233 8268 | 203   | 2    |
| 233 3716 | 303   | 34   | 233 4989 | 220   | 9    | 233 8379 | 279   | 40   |
| 233 3716 | 305   | 34   | 233 5203 | 181   | 20   | 233 8751 | 182   | 59   |
| 233 3721 | 326   | 54   | 233 5209 | 185   | 78   | 233 8761 | 187   | 93   |
| 233 3721 | 328   | 36   | 233 5240 | 291   | 50   | 233 8763 | 183   | 33   |
| 233 3723 | 323   | 37   | 233 5240 | 296   | 50   | 233 8763 | 186   | 10   |
| 233 3726 | 325   | 1    | 233 5258 | 292   | 220  | 233 8763 | 187   | 63   |
| 233 3728 | 323   | 1    | 233 5278 | 134   | 33   | 233 8763 | 187   | 84   |
| 233 3730 | 327   | 1    | 233 5333 | 311   | 36   | 233 8834 | 299   | 52   |
| 233 3797 | 159   | 8    | 233 5334 | 309   | 14   | 233 8960 | 190   | 31   |
| 233 3801 | 214   | 86   | 233 5351 | 278   | 83   | 233 8960 | 192   | 31   |
| 233 3801 | 217   | 11   | 233 5360 | 212   | 74   | 233 8979 | 258   | 14   |
| 233 3810 | 164   | 27   | 233 5360 | 221   | 14   | 233 9016 | 335   | 121  |
| 233 3811 | 164   | 28   | 233 5360 | 222   | 14   | 233 9255 | 95    | 26   |
| 233 3812 | 164   | 26   | 233 5361 | 212   | 75   | 233 9257 | 153   | 119  |

| TEILE-NR | SEITE | BILD | TEILE-NR | SEITE | BILD | TEILE-NR | SEITE | BILD |
|----------|-------|------|----------|-------|------|----------|-------|------|
| 233 9263 | 116   | 65   | 237 0588 | 225   | 51   | 237 3603 | 191   | 59   |
| 233 9263 | 121   | 65   | 237 0589 | 225   | 52   | 237 3603 | 192   | 59   |
| 233 9345 | 153   | 154  | 237 0830 | 160   | 36   | 237 3604 | 191   | 60   |
| 233 9601 | 217   | 13   | 237 0832 | 98    | 25   | 237 3604 | 192   | 60   |
| 233 9602 | 217   | 12   | 237 0832 | 101   | 74   | 237 3605 | 191   | 61   |
| 233 9602 | 219   | 8    | 237 0833 | 98    | 26   | 237 3605 | 192   | 61   |
| 233 9680 | 283   | 39   | 237 0833 | 101   | 75   | 237 3606 | 191   | 62   |
| 233 9812 | 197   | 21   | 237 0844 | 97    | 21   | 237 3606 | 192   | 62   |
| 233 9812 | 198   | 3    | 237 0844 | 100   | 73   | 237 3628 | 205   | 12   |
| 233 9812 | 199   | 22   | 237 0851 | 200   | 11   | 237 3628 | 206   | 12   |
| 233 9812 | 200   | 3    | 237 0851 | 202   | 13   | 237 3632 | 233   | 4    |
| 233 9813 | 197   | 22   | 237 0852 | 202   | 18   | 237 3633 | 233   | 5    |
| 233 9813 | 198   | 4    | 237 0870 | 204   | 18   | 237 4004 | 282   | 11   |
| 233 9813 | 199   | 23   | 237 0870 | 205   | 11   | 237 4004 | 284   | 15   |
| 233 9813 | 200   | 4    | 237 0870 | 206   | 11   | 237 4346 | 182   | 60   |
| 233 9818 | 160   | 33   | 237 0872 | 98    | 24   | 237 4363 | 159   | 7    |
| 233 9821 | 214   | 79   | 237 0872 | 101   | 76   | 237 4596 | 216   | 84   |
| 233 9821 | 216   | 79   | 237 0877 | 164   | 32   | 237 4611 | 216   | 87   |
| 233 9827 | 216   | 80   | 237 1094 | 315   | 1    | 237 4896 | 198   | 6    |
| 233 9827 | 217   | 21   | 237 1122 | 293   | 301  | 237 4896 | 200   | 6    |
| 233 9828 | 214   | 87   | 237 1122 | 297   | 284  | 237 4903 | 200   | 1    |
| 233 9828 | 217   | 14   | 237 1202 | 258   | 13   | 237 4909 | 200   | 8    |
| 233 9829 | 214   | 88   | 237 1395 | 143   | 31   | 237 4915 | 198   | 25   |
| 233 9829 | 217   | 15   | 237 1399 | 143   | 30   | 237 4918 | 198   | 1    |
| 233 9830 | 214   | 89   | 237 1583 | 293   | 299  | 237 4921 | 198   | 12   |
| 233 9830 | 217   | 16   | 237 1583 | 297   | 282  | 237 4927 | 263   | 14   |
| 233 9837 | 160   | 30   | 237 1658 | 189   | 21   | 237 4943 | 245   | 20   |
| 233 9914 | 313   | 24   | 237 1927 | 228   | 17   | 237 4944 | 245   | 21   |
| 233 9914 | 314   | 9    | 237 1927 | 229   | 17   | 237 4945 | 245   | 22   |
| 233 9915 | 313   | 35   | 237 2170 | 148   | 40   | 237 4946 | 245   | 12   |
| 233 9915 | 314   | 10   | 237 2170 | 149   | 40   | 237 4948 | 245   | 16   |
| 233 9918 | 250   | 1    | 237 2174 | 153   | 121  | 237 4951 | 245   | 24   |
| 233 9920 | 259   | 2    | 237 2175 | 153   | 122  | 237 4952 | 245   | 26   |
| 233 9934 | 259   | 7    | 237 2441 | 164   | 30   | 237 4954 | 246   | 29   |
| 235 2348 | 225   | 29   | 237 2442 | 164   | 31   | 237 4955 | 246   | 30   |
| 237 0100 | 276   | 92   | 237 2443 | 164   | 33   | 237 4956 | 246   | 31   |
| 237 0130 | 280   | 63   | 237 2476 | 87    | 13   | 237 4957 | 246   | 33   |
| 237 0314 | 281   | 27   | 237 2476 | 212   | 82   | 237 5057 | 200   | 26   |
| 237 0331 | 287   | 51   | 237 2477 | 332   | 86   | 237 5197 | 177   | 1    |
| 237 0332 | 287   | 52   | 237 2542 | 315   | 34   | 237 5329 | 313   | 36   |
| 237 0335 | 287   | 57   | 237 2587 | 315   | 35   | 237 5329 | 314   | 12   |
| 237 0350 | 281   | 11   | 237 2588 | 315   | 36   | 237 5476 | 293   | 298  |
| 237 0359 | 281   | 1    | 237 2589 | 315   | 33   | 237 5476 | 297   | 281  |
| 237 0359 | 286   | 1    | 237 2591 | 315   | 32   | 237 5478 | 292   | 241  |
| 237 0407 | 208   | 1    | 237 2606 | 315   | 31   | 237 5478 | 297   | 241  |
| 237 0408 | 208   | 2    | 237 2732 | 263   | 13   | 237 5479 | 293   | 300  |
| 237 0410 | 208   | 6    | 237 2747 | 215   | 35   | 237 5479 | 297   | 283  |
| 237 0411 | 208   | 4    | 237 2778 | 198   | 5    | 237 5588 | 219   | 7    |
| 237 0412 | 209   | 29   | 237 2778 | 200   | 5    | 237 5589 | 219   | 6    |
| 237 0419 | 209   | 28   | 237 2956 | 236   | 1    | 237 5590 | 219   | 4    |
| 237 0572 | 225   | 53   | 237 2957 | 236   | 2    | 237 5591 | 219   | 3    |
| 237 0573 | 225   | 55   | 237 2959 | 236   | 3    | 237 5592 | 219   | 5    |
| 237 0574 | 225   | 56   | 237 2960 | 236   | 4    | 237 5799 | 228   | 5    |
| 237 0575 | 225   | 57   | 237 2972 | 247   | 21   | 237 6233 | 169   | 37   |
| 237 0583 | 220   | 27   | 237 2997 | 182   | 53   | 237 6233 | 171   | 37   |
| 237 0583 | 221   | 28   | 237 3279 | 281   | 8    | 237 6233 | 174   | 43   |
| 237 0584 | 220   | 28   | 237 3279 | 286   | 8    | 237 6233 | 176   | 43   |
| 237 0584 | 221   | 29   | 237 3286 | 315   | 37   | 237 6244 | 247   | 26   |
| 237 0585 | 220   | 25   | 237 3460 | 181   | 8    | 237 6248 | 101   | 79   |
| 237 0585 | 221   | 26   | 237 3460 | 182   | 43   | 237 6358 | 284   | 30   |
| 237 0586 | 220   | 21   | 237 3524 | 153   | 123  | 237 6570 | 258   | 15   |
| 237 0587 | 220   | 29   | 237 3584 | 316   | 8    | 237 6571 | 258   | 16   |

| TEILE-NR | SEITE | BILD | TEILE-NR | SEITE | BILD | TEILE-NR | SEITE | BILD |
|----------|-------|------|----------|-------|------|----------|-------|------|
| 237 6738 | 217   | 17   | 237 8583 | 320   | 1    | 238 1087 | 112   | 975  |
| 237 6749 | 196   | 2    | 237 8592 | 320   | 7    | 238 1088 | 112   | 976  |
| 237 6769 | 183   | 4    | 237 8595 | 319   | 1    | 238 1111 | 145   | 17   |
| 237 6769 | 183   | 9    | 237 8617 | 316   | 1    | 238 1111 | 147   | 14   |
| 237 6770 | 154   | 176  | 237 8618 | 316   | 2    | 238 1112 | 145   | 18   |
| 237 6837 | 315   | 3    | 237 8619 | 316   | 9    | 238 1112 | 147   | 15   |
| 237 7012 | 193   | 74   | 237 8620 | 316   | 14   | 238 1184 | 132   | 32   |
| 237 7012 | 191   | 75   | 237 8621 | 316   | 12   | 238 1193 | 182   | 50   |
| 237 7014 | 193   | 70   | 237 8634 | 317   | 25   | 238 1195 | 181   | 11   |
| 237 7014 | 191   | 71   | 237 8634 | 318   | 25   | 238 1195 | 181   | 23   |
| 237 7119 | 166   | 15   | 237 8635 | 317   | 21   | 238 1196 | 181   | 24   |
| 237 7119 | 167   | 16   | 237 8635 | 318   | 21   | 238 1197 | 181   | 12   |
| 237 7120 | 166   | 18   | 237 8645 | 317   | 16   | 238 1199 | 186   | 1    |
| 237 7120 | 167   | 19   | 237 8645 | 318   | 17   | 238 1200 | 186   | 2    |
| 237 7133 | 229   | 4    | 237 8647 | 317   | 24   | 238 1201 | 182   | 49   |
| 237 7135 | 229   | 3    | 237 8647 | 318   | 24   | 238 1202 | 187   | 91   |
| 237 7137 | 229   | 2    | 237 8881 | 149   | 49   | 238 1203 | 187   | 92   |
| 237 7139 | 229   | 1    | 237 8910 | 103   | 28   | 238 1204 | 187   | 81   |
| 237 7173 | 282   | 12   | 237 8913 | 104   | 29   | 238 1205 | 187   | 82   |
| 237 7174 | 282   | 14   | 237 8916 | 149   | 57   | 238 1206 | 186   | 4    |
| 237 7175 | 282   | 17   | 237 8921 | 149   | 56   | 238 1207 | 186   | 3    |
| 237 7175 | 284   | 78   | 237 8924 | 149   | 58   | 238 1210 | 267   | 1    |
| 237 7200 | 292   | 261  | 237 8933 | 153   | 157  | 238 1211 | 268   | 26   |
| 237 7200 | 297   | 274  | 237 8935 | 153   | 158  | 238 1212 | 267   | 4    |
| 237 7448 | 228   | 1    | 237 8936 | 153   | 159  | 238 1213 | 269   | 27   |
| 237 7450 | 228   | 2    | 237 8938 | 154   | 174  | 238 1214 | 267   | 19   |
| 237 7452 | 228   | 3    | 237 8939 | 151   | 13   | 238 1215 | 267   | 18   |
| 237 7453 | 228   | 8    | 237 8943 | 154   | 171  | 238 1373 | 170   | 48   |
| 237 7453 | 229   | 8    | 237 8947 | 197   | 24   | 238 1373 | 171   | 39   |
| 237 7464 | 250   | 2    | 237 8947 | 199   | 25   | 238 1373 | 174   | 48   |
| 237 7465 | 250   | 3    | 237 8948 | 154   | 173  | 238 1373 | 176   | 45   |
| 237 7480 | 292   | 242  | 237 8968 | 151   | 16   | 238 1381 | 170   | 47   |
| 237 7480 | 297   | 242  | 237 9114 | 293   | 297  | 238 1381 | 171   | 38   |
| 237 7485 | 303   | 29   | 237 9114 | 297   | 280  | 238 1381 | 174   | 47   |
| 237 7485 | 305   | 29   | 237 9157 | 200   | 10   | 238 1381 | 176   | 44   |
| 237 7511 | 318   | 8    | 237 9157 | 202   | 2    | 238 1386 | 171   | 40   |
| 237 7512 | 317   | 6    | 237 9161 | 198   | 23   | 238 1391 | 176   | 50   |
| 237 7512 | 318   | 6    | 237 9161 | 200   | 24   | 238 1576 | 252   | 40   |
| 237 7512 | 319   | 3    | 237 9168 | 216   | 88   | 238 1587 | 154   | 177  |
| 237 7512 | 320   | 3    | 237 9647 | 284   | 27   | 238 1650 | 228   | 12   |
| 237 7513 | 317   | 8    | 237 9649 | 284   | 18   | 238 1651 | 228   | 13   |
| 237 7514 | 318   | 7    | 237 9661 | 284   | 1    | 238 1652 | 228   | 14   |
| 237 7646 | 207   | 23   | 237 9661 | 297   | 266  | 238 1652 | 229   | 22   |
| 237 7738 | 317   | 3    | 237 9675 | 317   | 7    | 238 1653 | 228   | 15   |
| 237 7749 | 317   | 2    | 237 9684 | 297   | 247  | 238 1653 | 229   | 20   |
| 237 7751 | 318   | 3    | 238 0014 | 293   | 302  | 238 1654 | 228   | 16   |
| 237 7753 | 318   | 2    | 238 0014 | 297   | 285  | 238 1654 | 229   | 15   |
| 237 7756 | 317   | 5    | 238 0163 | 216   | 95   | 238 1657 | 229   | 21   |
| 237 7756 | 318   | 5    | 238 0194 | 216   | 90   | 238 1659 | 228   | 18   |
| 237 7756 | 319   | 2    | 238 0547 | 300   | 84   | 238 1661 | 229   | 19   |
| 237 7756 | 320   | 2    | 238 0723 | 305   | 41   | 238 1663 | 229   | 13   |
| 237 7757 | 318   | 4    | 238 0723 | 307   | 2    | 238 1664 | 228   | 19   |
| 237 7758 | 317   | 4    | 238 0742 | 280   | 57   | 238 1664 | 229   | 14   |
| 237 7894 | 105   | 25   | 238 0742 | 290   | 14   | 238 1665 | 229   | 18   |
| 237 8096 | 317   | 1    | 238 0742 | 295   | 14   | 238 1822 | 247   | 25   |
| 237 8098 | 318   | 1    | 238 0742 | 302   | 7    | 238 1833 | 247   | 28   |
| 237 8235 | 316   | 7    | 238 1081 | 111   | 113  | 238 1948 | 98    | 27   |
| 237 8273 | 316   | 4    | 238 1082 | 112   | 970  | 238 1951 | 101   | 80   |
| 237 8541 | 237   | 1    | 238 1083 | 112   | 971  | 238 1955 | 262   | 7    |
| 237 8542 | 237   | 2    | 238 1084 | 112   | 972  | 238 1956 | 262   | 8    |
| 237 8553 | 237   | 6    | 238 1085 | 112   | 973  | 238 2022 | 154   | 193  |
| 237 8577 | 315   | 6    | 238 1086 | 112   | 974  | 238 2025 | 154   | 195  |

| TEILE-NR | SEITE | BILD | TEILE-NR | SEITE | BILD | TEILE-NR  | SEITE | BILD |
|----------|-------|------|----------|-------|------|-----------|-------|------|
| 238 2233 | 298   | 297  | 238 6548 | 132   | 21   | 336 238 2 | 35    | 952  |
| 238 2415 | 193   | 64   | 238 6617 | 248   | 13   | 336 238 3 | 35    | 953  |
| 238 2416 | 193   | 68   | 238 6619 | 248   | 14   | 336 238 4 | 35    | 954  |
| 238 2417 | 193   | 66   | 238 6621 | 248   | 11   | 336 238 5 | 35    | 955  |
| 238 2473 | 300   | 80   | 238 6623 | 248   | 10   | 336 2498  | 44    | 1    |
| 238 2491 | 297   | 256  | 238 6710 | 239   | 12   | 336 2504  | 40    | 1    |
| 238 2756 | 186   | 46   | 238 6710 | 244   | 28   | 336 2504  | 41    | 1    |
| 238 2758 | 181   | 31   | 238 6710 | 245   | 23   | 336 2505  | 37    | 7    |
| 238 2761 | 181   | 27   | 238 6711 | 239   | 13   | 336 2510  | 39    | 1    |
| 238 2763 | 186   | 50   | 238 6712 | 239   | 14   | 336 2538  | 36    | 5    |
| 238 2765 | 186   | 48   | 238 6714 | 239   | 16   | 336 2541  | 36    | 4    |
| 238 2769 | 206   | 1    | 238 6973 | 243   | 21   | 336 2573  | 46    | 5    |
| 238 2774 | 181   | 28   | 238 6973 | 245   | 19   | 336 2573  | 47    | 3    |
| 238 2777 | 181   | 23   | 238 6974 | 245   | 15   | 336 2737  | 49    | 2    |
| 238 2782 | 186   | 44   | 238 6975 | 243   | 16   | 336 2983  | 61    | 1    |
| 238 2789 | 206   | 3    | 238 6976 | 132   | 26   | 336 3064  | 63    | 9    |
| 238 2799 | 246   | 47   | 238 6978 | 243   | 27   | 336 3069  | 64    | 2    |
| 238 2800 | 244   | 29   | 238 6978 | 246   | 40   | 336 3070  | 64    | 1    |
| 238 2801 | 240   | 9    | 238 6991 | 246   | 36   | 336 3502  | 201   | 19   |
| 238 2803 | 269   | 7    | 238 6982 | 243   | 25   | 336 3503  | 201   | 20   |
| 238 2881 | 310   | 19   | 238 6985 | 246   | 42   | 336 3505  | 201   | 21   |
| 238 2881 | 312   | 39   | 238 6986 | 246   | 43   | 336 3511  | 201   | 18   |
| 238 2887 | 307   | 1    | 238 6987 | 246   | 44   | 336 3646  | 331   | 51   |
| 238 2905 | 305   | 40   | 238 6989 | 244   | 46   | 336 3646  | 334   | 51   |
| 238 2905 | 307   | 4    | 238 7266 | 233   | 14   | 336 3658  | 76    | 2    |
| 238 3036 | 222   | 20   | 238 7267 | 233   | 11   | 336 3913  | 83    | 4    |
| 238 4202 | 273   | 54   | 238 8060 | 123   | 85   | 336 3929  | 205   | 5    |
| 238 4203 | 270   | 28   | 238 8062 | 123   | 86   | 336 3929  | 206   | 4    |
| 238 4203 | 273   | 55   | 238 8144 | 121   | 67   | 336 3977  | 87    | 17   |
| 238 4204 | 270   | 28   | 238 8144 | 123   | 88   | 336 4291  | 275   | 13   |
| 238 4210 | 139   | 24   | 238 8686 | 193   | 69   | 336 4291  | 277   | 13   |
| 238 4365 | 305   | 42   | 238 8686 | 191   | 70   | 336 5861  | 59    | 15   |
| 238 4366 | 306   | 43   | 238 8887 | 160   | 47   | 336 7789  | 58    | 2    |
| 238 4619 | 300   | 87   | 238 8889 | 160   | 48   | 336 9305  | 55    | 6    |
| 238 4642 | 285   | 24   | 238 9034 | 304   | 51   | 337 1612  | 52    | 3    |
| 238 4654 | 297   | 263  | 238 9034 | 306   | 50   | 337 1650  | 53    | 2    |
| 238 4775 | 216   | 96   | 238 9220 | 216   | 86   | 337 1666  | 56    | 22   |
| 238 4799 | 160   | 45   | 238 9528 | 229   | 5    | 337 1689  | 74    | 1    |
| 238 4813 | 166   | 19   | 296 2779 | 179   | 7    | 337 1689  | 83    | 1    |
| 238 4813 | 167   | 20   | 330 8925 | 156   | 2    | 337 1689  | 84    | 1    |
| 238 5142 | 315   | 9    | 331 5353 | 291   | 42   | 337 1692  | 57    | 4    |
| 238 5248 | 177   | 15   | 331 5353 | 295   | 42   | 337 1748  | 55    | 4    |
| 238 5441 | 133   | 4    | 331 6466 | 83    | 3    | 337 1761  | 55    | 10   |
| 238 5450 | 133   | 29   | 331 6466 | 84    | 3    | 337 1866  | 59    | 10   |
| 238 5576 | 159   | 11   | 331 6466 | 205   | 6    | 337 1867  | 59    | 11   |
| 238 5576 | 160   | 46   | 331 6466 | 206   | 7    | 337 1876  | 59    | 5    |
| 238 5579 | 159   | 1    | 332 7796 | 144   | 13   | 337 1881  | 59    | 3    |
| 238 5878 | 238   | 7    | 332 7796 | 145   | 13   | 337 1885  | 59    | 1    |
| 238 5878 | 239   | 7    | 332 7796 | 146   | 13   | 337 1887  | 59    | 4    |
| 238 5879 | 239   | 11   | 332 7796 | 147   | 13   | 337 2164  | 68    | 1    |
| 238 6000 | 105   | 26   | 334 9653 | 158   | 25   | 337 2269  | 70    | 4    |
| 238 6039 | 285   | 23   | 335 1864 | 261   | 2    | 338 6499  | 224   | 1    |
| 238 6341 | 255   | 15   | 335 1864 | 262   | 2    | 338 6770  | 115   | 21   |
| 238 6353 | 234   | 33   | 336 1809 | 77    | 5    | 338 6770  | 117   | 22   |
| 238 6354 | 234   | 34   | 336 2279 | 34    | 15   | 338 6770  | 119   | 22   |
| 238 6360 | 234   | 31   | 336 2293 | 39    | 3    | 338 6770  | 120   | 21   |
| 238 6361 | 234   | 32   | 336 2294 | 39    | 4    | 338 6770  | 122   | 22   |
| 238 6382 | 233   | 1    | 336 2295 | 39    | 5    | 338 6770  | 125   | 4    |
| 238 6383 | 233   | 3    | 336 2337 | 35    | 22   | 338 6770  | 126   | 28   |
| 238 6384 | 233   | 2    | 336 2379 | 34    | 2    | 338 6862  | 166   | 3    |
| 238 6503 | 198   | 26   | 336 2380 | 35    | 950  | 338 6958  | 161   | 22   |
| 238 6503 | 200   | 27   | 336 2381 | 35    | 951  | 338 6958  | 162   | 22   |

| TEILE-NR | SEITE | BILD | TEILE-NR | SEITE | BILD | TEILE-NR | SEITE | BILD |
|----------|-------|------|----------|-------|------|----------|-------|------|
| 33E 6958 | 163   | 15   | 338 8928 | 156   | 6    | 338 9326 | 173   | 6    |
| 33E 6958 | 164   | 15   | 338 8929 | 142   | 3    | 338 9326 | 175   | 1    |
| 33E 6962 | 169   | 23   | 338 8929 | 143   | 3    | 338 932E | 173   | 7    |
| 33E 6962 | 173   | 27   | 338 8929 | 156   | 7    | 338 932E | 175   | 2    |
| 33E 7157 | 269   | 3    | 338 8930 | 156   | 11   | 338 9331 | 169   | 1    |
| 33E 7158 | 269   | 2    | 338 8954 | 166   | 2    | 338 9331 | 171   | 1    |
| 33E 7372 | 169   | 38   | 338 8966 | 177   | 6    | 338 9333 | 170   | 52   |
| 33E 7372 | 171   | 25   | 338 8969 | 177   | 12   | 338 9333 | 172   | 48   |
| 33E 7372 | 173   | 4    | 338 8970 | 177   | 13   | 338 9333 | 174   | 35   |
| 33E 7372 | 175   | 28   | 338 8971 | 177   | 14   | 338 9333 | 176   | 53   |
| 33E 7406 | 177   | 23   | 338 8973 | 177   | 16   | 338 9335 | 170   | 53   |
| 33E 7406 | 179   | 32   | 338 8973 | 180   | 61   | 338 9335 | 172   | 49   |
| 33E 7415 | 177   | 3    | 338 8975 | 177   | 25   | 338 9335 | 174   | 36   |
| 33E 7574 | 322   | 53   | 338 8977 | 178   | 950  | 338 9335 | 176   | 54   |
| 33E 7577 | 322   | 52   | 338 8978 | 178   | 951  | 338 9438 | 211   | 7    |
| 33E 7582 | 260   | 3    | 338 8979 | 178   | 952  | 338 9460 | 211   | 15   |
| 33E 7583 | 260   | 2    | 338 8980 | 178   | 953  | 338 9468 | 230   | 11   |
| 33E 7604 | 137   | 4    | 338 9040 | 204   | 4    | 338 9469 | 230   | 12   |
| 33E 7606 | 144   | 12   | 338 9041 | 204   | 5    | 338 9484 | 235   | 1    |
| 33E 7606 | 145   | 12   | 338 9042 | 204   | 9    | 338 9485 | 235   | 2    |
| 33E 7614 | 256   | 6    | 338 9073 | 214   | 25   | 338 9517 | 274   | 2    |
| 33E 7614 | 314   | 4    | 338 9107 | 212   | 38   | 338 9709 | 230   | 10   |
| 33E 7615 | 313   | 25   | 338 9239 | 274   | 5    | 338 9898 | 258   | 20   |
| 33E 7615 | 321   | 19   | 338 9261 | 93    | 10   | 338 9902 | 274   | 1    |
| 33E 7618 | 256   | 4    | 338 9261 | 95    | 19   | 339 0246 | 224   | 7    |
| 33E 7618 | 258   | 6    | 338 9261 | 321   | 13   | 339 0416 | 124   | 4    |
| 33E 7618 | 321   | 24   | 338 9276 | 105   | 4    | 339 0419 | 128   | 17   |
| 33E 7742 | 156   | 14   | 338 9292 | 156   | 15   | 339 0425 | 129   | 35   |
| 33E 7776 | 97    | 10   | 338 9301 | 166   | 4    | 339 0427 | 128   | 18   |
| 33E 7776 | 98    | 10   | 338 9303 | 169   | 7    | 339 0428 | 128   | 27   |
| 33E 7776 | 156   | 19   | 338 9303 | 171   | 7    | 339 0428 | 131   | 34   |
| 33E 7776 | 161   | 26   | 338 9303 | 173   | 13   | 339 0433 | 128   | 8    |
| 33E 7776 | 162   | 26   | 338 9303 | 175   | 11   | 339 0470 | 169   | 18   |
| 33E 7776 | 163   | 14   | 338 9306 | 171   | 8    | 339 0470 | 171   | 18   |
| 33E 7776 | 164   | 14   | 338 9306 | 173   | 14   | 339 0470 | 173   | 23   |
| 33E 7849 | 177   | 24   | 338 9306 | 175   | 12   | 339 0470 | 175   | 22   |
| 33E 7849 | 179   | 31   | 338 9308 | 169   | 16   | 339 0472 | 169   | 17   |
| 33E 7850 | 177   | 22   | 338 9308 | 173   | 21   | 339 0472 | 171   | 17   |
| 33E 7869 | 182   | 48   | 338 9309 | 171   | 19   | 339 0472 | 173   | 22   |
| 33E 7869 | 183   | 22   | 338 9309 | 173   | 24   | 339 0472 | 175   | 21   |
| 33E 7869 | 187   | 60   | 338 9309 | 175   | 23   | 339 0826 | 186   | 7    |
| 33E 7988 | 211   | 21   | 338 9310 | 173   | 5    | 339 0829 | 185   | 91   |
| 33E 7988 | 302   | 10   | 338 9314 | 169   | 39   | 339 0951 | 99    | 64   |
| 33E 8085 | 223   | 4    | 338 9314 | 172   | 45   | 339 0951 | 101   | 64   |
| 33E 8086 | 223   | 5    | 338 9314 | 174   | 32   | 339 1356 | 179   | 13   |
| 33E 8203 | 258   | 11   | 338 9314 | 176   | 47   | 339 1784 | 177   | 17   |
| 33E 8292 | 201   | 22   | 338 9319 | 169   | 2    | 339 1788 | 179   | 34   |
| 33E 8292 | 202   | 16   | 338 9319 | 171   | 2    | 339 1789 | 179   | 35   |
| 33E 8321 | 207   | 12   | 338 9319 | 173   | 10   | 339 1790 | 179   | 36   |
| 33E 8321 | 209   | 30   | 338 9319 | 175   | 5    | 339 1791 | 179   | 37   |
| 33E 8444 | 169   | 11   | 338 9320 | 169   | 3    | 339 1856 | 107   | 43   |
| 33E 8444 | 171   | 11   | 338 9320 | 171   | 3    | 339 1875 | 108   | 950  |
| 33E 8444 | 173   | 16   | 338 9320 | 173   | 11   | 339 1875 | 112   | 965  |
| 33E 8444 | 175   | 14   | 338 9320 | 175   | 6    | 339 1876 | 108   | 951  |
| 33E 8449 | 169   | 9    | 338 9321 | 170   | 50   | 339 1876 | 112   | 966  |
| 33E 8449 | 171   | 9    | 338 9321 | 172   | 46   | 339 1877 | 108   | 952  |
| 33E 8449 | 173   | 15   | 338 9321 | 174   | 33   | 339 1877 | 112   | 967  |
| 33E 8449 | 175   | 13   | 338 9321 | 176   | 51   | 339 1878 | 108   | 953  |
| 33E 8584 | 247   | 19   | 338 9323 | 170   | 51   | 339 1878 | 112   | 968  |
| 33E 8595 | 194   | 2    | 338 9323 | 172   | 47   | 339 1879 | 108   | 954  |
| 33E 8928 | 142   | 4    | 338 9323 | 174   | 34   | 339 1879 | 112   | 969  |
| 33E 8928 | 143   | 4    | 338 9323 | 176   | 52   | 339 1880 | 107   | 52   |

| TEILE-NR | SEITE | BILD | TEILE-NR | SEITE | BILD | TEILE-NR | SEITE | BILD |
|----------|-------|------|----------|-------|------|----------|-------|------|
| 339 1880 | 110   | 58   | 339 2087 | 144   | 10   | 339 2336 | 136   | 9    |
| 339 1926 | 116   | 43   | 339 2087 | 145   | 10   | 339 2340 | 136   | 9    |
| 339 1926 | 121   | 43   | 339 2087 | 146   | 10   | 339 2341 | 136   | 11   |
| 339 1929 | 115   | 17   | 339 2087 | 147   | 10   | 339 2343 | 136   | 20   |
| 339 1929 | 117   | 12   | 339 2087 | 148   | 21   | 339 2345 | 136   | 15   |
| 339 1929 | 120   | 17   | 339 2100 | 155   | 3    | 339 2346 | 144   | 4    |
| 339 1929 | 122   | 12   | 339 2102 | 155   | 5    | 339 2346 | 145   | 4    |
| 339 1933 | 115   | 33   | 339 2118 | 157   | 18   | 339 2347 | 144   | 3    |
| 339 1933 | 120   | 23   | 339 2119 | 157   | 17   | 339 2347 | 145   | 3    |
| 339 1935 | 115   | 2    | 339 2123 | 157   | 20   | 339 2351 | 108   | 92   |
| 339 1935 | 120   | 1    | 339 2124 | 157   | 21   | 339 2354 | 134   | 3    |
| 339 1937 | 115   | 15   | 339 2125 | 158   | 22   | 339 2355 | 134   | 4    |
| 339 1943 | 115   | 13   | 339 2126 | 158   | 23   | 339 2361 | 136   | 3    |
| 339 1943 | 117   | 11   | 339 2127 | 158   | 24   | 339 2365 | 136   | 18   |
| 339 1943 | 120   | 13   | 339 2130 | 158   | 30   | 339 2366 | 136   | 17   |
| 339 1943 | 122   | 11   | 339 2133 | 158   | 32   | 339 2375 | 144   | 5    |
| 339 1944 | 115   | 32   | 339 2138 | 157   | 16   | 339 2375 | 145   | 5    |
| 339 1944 | 117   | 19   | 339 2153 | 270   | 11   | 339 2377 | 144   | 15   |
| 339 1944 | 120   | 32   | 339 2192 | 107   | 12   | 339 2377 | 145   | 15   |
| 339 1944 | 122   | 19   | 339 2201 | 107   | 18   | 339 2378 | 144   | 11   |
| 339 1950 | 115   | 25   | 339 2202 | 107   | 19   | 339 2378 | 145   | 11   |
| 339 1950 | 120   | 25   | 339 2206 | 107   | 21   | 339 2383 | 158   | 29   |
| 339 1955 | 124   | 9    | 339 2207 | 107   | 13   | 339 2391 | 102   | 13   |
| 339 1955 | 323   | 40   | 339 2213 | 107   | 29   | 339 2425 | 108   | 97   |
| 339 1955 | 326   | 55   | 339 2219 | 107   | 42   | 339 2440 | 108   | 98   |
| 339 1955 | 328   | 41   | 339 2221 | 107   | 44   | 339 2440 | 111   | 72   |
| 339 1965 | 126   | 6    | 339 2223 | 107   | 45   | 339 2442 | 108   | 103  |
| 339 1966 | 126   | 7    | 339 2224 | 108   | 54   | 339 2442 | 111   | 65   |
| 339 1969 | 126   | 22   | 339 2225 | 107   | 48   | 339 2443 | 108   | 93   |
| 339 1970 | 126   | 5    | 339 2233 | 107   | 62   | 339 2443 | 111   | 68   |
| 339 1971 | 126   | 9    | 339 2235 | 107   | 65   | 339 2471 | 115   | 4    |
| 339 1974 | 126   | 25   | 339 2235 | 111   | 77   | 339 2471 | 120   | 4    |
| 339 1976 | 126   | 33   | 339 2236 | 107   | 66   | 339 2477 | 115   | 36   |
| 339 1977 | 126   | 35   | 339 2237 | 107   | 5    | 339 2477 | 120   | 36   |
| 339 1985 | 126   | 38   | 339 2239 | 107   | 22   | 339 2478 | 116   | 37   |
| 339 1985 | 127   | 963  | 339 2243 | 107   | 35   | 339 2478 | 120   | 37   |
| 339 1986 | 127   | 950  | 339 2245 | 107   | 34   | 339 2480 | 116   | 42   |
| 339 1987 | 127   | 951  | 339 2246 | 107   | 33   | 339 2480 | 121   | 42   |
| 339 1988 | 127   | 952  | 339 2256 | 107   | 15   | 339 2494 | 134   | 12   |
| 339 1989 | 127   | 953  | 339 2257 | 107   | 23   | 339 2497 | 134   | 27   |
| 339 1990 | 127   | 954  | 339 2258 | 107   | 24   | 339 2503 | 134   | 11   |
| 339 1991 | 127   | 955  | 339 2261 | 116   | 39   | 339 2504 | 135   | 950  |
| 339 1992 | 127   | 956  | 339 2261 | 121   | 39   | 339 2505 | 135   | 951  |
| 339 1993 | 127   | 957  | 339 2264 | 116   | 41   | 339 2506 | 135   | 952  |
| 339 1995 | 127   | 958  | 339 2270 | 272   | 29   | 339 2508 | 135   | 953  |
| 339 1996 | 127   | 959  | 339 2271 | 130   | 1    | 339 2511 | 135   | 954  |
| 339 1997 | 127   | 960  | 339 2273 | 130   | 4    | 339 2513 | 135   | 955  |
| 339 1998 | 127   | 961  | 339 2275 | 130   | 9    | 339 2522 | 135   | 956  |
| 339 1999 | 127   | 962  | 339 2276 | 130   | 10   | 339 2540 | 137   | 1    |
| 339 2000 | 127   | 51   | 339 2277 | 130   | 11   | 339 2547 | 146   | 8    |
| 339 2001 | 127   | 54   | 339 2280 | 130   | 17   | 339 2547 | 147   | 8    |
| 339 2002 | 128   | 1    | 339 2282 | 130   | 15   | 339 2553 | 146   | 7    |
| 339 2004 | 128   | 4    | 339 2285 | 130   | 24   | 339 2553 | 147   | 7    |
| 339 2007 | 128   | 21   | 339 2287 | 130   | 26   | 339 2556 | 157   | 3    |
| 339 2009 | 129   | 950  | 339 2288 | 131   | 29   | 339 2599 | 331   | 43   |
| 339 2010 | 129   | 951  | 339 2292 | 131   | 950  | 339 3176 | 124   | 17   |
| 339 2011 | 129   | 952  | 339 2293 | 131   | 951  | 339 3176 | 125   | 11   |
| 339 2013 | 129   | 953  | 339 2294 | 131   | 952  | 339 3268 | 148   | 28   |
| 339 2015 | 129   | 954  | 339 2295 | 131   | 953  | 339 3268 | 149   | 28   |
| 339 2016 | 129   | 955  | 339 2296 | 131   | 954  | 339 9309 | 169   | 19   |
| 339 2017 | 129   | 956  | 339 2304 | 130   | 23   | 339 9777 | 308   | 1    |
| 339 2069 | 136   | 14   | 339 2325 | 136   | 5    | 339 9990 | 314   | 3    |

| TEILE-NR | SEITE | BILD | TEILE-NR | SEITE | BILD | TEILE-NR  | SEITE | BILD |
|----------|-------|------|----------|-------|------|-----------|-------|------|
| 340 0021 | 293   | 306  | 340 0937 | 333   | 14   | 340 135 0 | 327   | 18   |
| 340 0021 | 298   | 301  | 340 0943 | 332   | 100  | 340 135 1 | 325   | 5    |
| 340 0133 | 291   | 108  | 340 0945 | 331   | 33   | 340 135 1 | 327   | 4    |
| 340 0133 | 296   | 108  | 340 1061 | 313   | 9    | 340 135 2 | 325   | 11   |
| 340 0134 | 291   | 109  | 340 1280 | 282   | 6    | 340 135 2 | 328   | 31   |
| 340 0134 | 296   | 109  | 340 1280 | 284   | 6    | 340 135 5 | 325   | 14   |
| 340 0135 | 291   | 111  | 340 1281 | 301   | 6    | 340 135 6 | 325   | 15   |
| 340 0135 | 296   | 111  | 340 1282 | 291   | 47   | 340 135 7 | 325   | 16   |
| 340 0143 | 291   | 110  | 340 1282 | 292   | 263  | 340 135 8 | 325   | 17   |
| 340 0143 | 296   | 110  | 340 1282 | 296   | 47   | 340 135 8 | 327   | 10   |
| 340 0162 | 291   | 118  | 340 1282 | 297   | 271  | 340 135 9 | 325   | 18   |
| 340 0162 | 296   | 118  | 340 1283 | 329   | 1    | 340 135 9 | 327   | 14   |
| 340 0205 | 303   | 10   | 340 1287 | 290   | 5    | 340 136 0 | 325   | 19   |
| 340 0205 | 305   | 10   | 340 1287 | 295   | 5    | 340 136 0 | 327   | 11   |
| 340 0220 | 303   | 20   | 340 1288 | 290   | 6    | 340 136 7 | 301   | 7    |
| 340 0220 | 305   | 20   | 340 1288 | 295   | 6    | 340 136 8 | 301   | 9    |
| 340 0220 | 313   | 8    | 340 1297 | 291   | 49   | 340 137 8 | 291   | 65   |
| 340 0259 | 314   | 1    | 340 1297 | 296   | 49   | 340 137 8 | 296   | 65   |
| 340 0301 | 336   | 1    | 340 1303 | 291   | 121  | 340 139 0 | 291   | 87   |
| 340 0302 | 336   | 950  | 340 1303 | 296   | 121  | 340 139 0 | 296   | 87   |
| 340 0303 | 336   | 951  | 340 1306 | 282   | 4    | 340 139 1 | 291   | 88   |
| 340 0304 | 336   | 952  | 340 1306 | 284   | 5    | 340 139 1 | 296   | 88   |
| 340 0341 | 308   | 9    | 340 1307 | 282   | 9    | 340 139 2 | 280   | 72   |
| 340 0342 | 314   | 2    | 340 1307 | 284   | 12   | 340 139 2 | 291   | 94   |
| 340 0412 | 304   | 52   | 340 1309 | 282   | 15   | 340 139 2 | 296   | 94   |
| 340 0412 | 306   | 51   | 340 1309 | 284   | 26   | 340 139 8 | 301   | 12   |
| 340 0495 | 334   | 23   | 340 1320 | 290   | 26   | 340 140 0 | 291   | 72   |
| 340 0561 | 275   | 2    | 340 1320 | 295   | 26   | 340 140 0 | 296   | 72   |
| 340 0561 | 277   | 2    | 340 1321 | 293   | 281  | 340 140 1 | 291   | 73   |
| 340 0563 | 275   | 5    | 340 1321 | 297   | 290  | 340 140 1 | 296   | 73   |
| 340 0563 | 277   | 5    | 340 1325 | 283   | 41   | 340 140 2 | 291   | 75   |
| 340 0601 | 304   | 45   | 340 1325 | 285   | 35   | 340 140 2 | 296   | 75   |
| 340 0601 | 306   | 49   | 340 1325 | 290   | 40   | 340 140 4 | 291   | 78   |
| 340 0705 | 330   | 27   | 340 1325 | 295   | 40   | 340 140 4 | 296   | 78   |
| 340 0705 | 333   | 27   | 340 1326 | 292   | 140  | 340 140 5 | 291   | 80   |
| 340 0736 | 275   | 15   | 340 1326 | 297   | 140  | 340 140 5 | 296   | 80   |
| 340 0736 | 277   | 15   | 340 1327 | 291   | 44   | 340 140 6 | 291   | 81   |
| 340 0761 | 277   | 29   | 340 1327 | 295   | 44   | 340 140 6 | 296   | 81   |
| 340 0802 | 280   | 54   | 340 1328 | 291   | 64   | 340 140 7 | 291   | 83   |
| 340 0803 | 280   | 64   | 340 1328 | 296   | 64   | 340 140 7 | 296   | 83   |
| 340 0806 | 280   | 53   | 340 1334 | 323   | 2    | 340 140 8 | 291   | 84   |
| 340 0816 | 280   | 55   | 340 1335 | 323   | 3    | 340 140 8 | 296   | 84   |
| 340 0825 | 326   | 61   | 340 1337 | 323   | 5    | 340 140 9 | 291   | 92   |
| 340 0827 | 326   | 62   | 340 1338 | 323   | 6    | 340 140 9 | 296   | 92   |
| 340 0828 | 326   | 63   | 340 1340 | 323   | 9    | 340 141 1 | 301   | 11   |
| 340 0829 | 326   | 65   | 340 1340 | 325   | 7    | 340 141 2 | 301   | 3    |
| 340 0830 | 290   | 27   | 340 1340 | 327   | 20   | 340 142 1 | 291   | 89   |
| 340 0830 | 295   | 27   | 340 1342 | 323   | 11   | 340 142 1 | 296   | 89   |
| 340 0830 | 325   | 24   | 340 1343 | 323   | 15   | 340 144 2 | 309   | 2    |
| 340 0835 | 303   | 9    | 340 1343 | 325   | 9    | 340 144 2 | 310   | 2    |
| 340 0835 | 305   | 9    | 340 1343 | 327   | 21   | 340 180 4 | 313   | 33   |
| 340 0865 | 313   | 13   | 340 1344 | 323   | 16   | 346 959 6 | 62    | 3    |
| 340 0865 | 321   | 17   | 340 1344 | 325   | 8    | 347 107 6 | 207   | 13   |
| 340 0866 | 313   | 14   | 340 1344 | 327   | 7    | 347 107 6 | 209   | 31   |
| 340 0867 | 313   | 15   | 340 1345 | 323   | 17   | 347 108 5 | 263   | 3    |
| 340 0869 | 313   | 23   | 340 1345 | 325   | 6    | 347 112 2 | 137   | 3    |
| 340 0871 | 313   | 11   | 340 1345 | 327   | 19   | 347 112 3 | 137   | 7    |
| 340 0874 | 313   | 19   | 340 1348 | 325   | 2    | 347 126 5 | 281   | 5    |
| 340 0922 | 331   | 25   | 340 1348 | 327   | 17   | 347 126 5 | 286   | 5    |
| 340 0923 | 331   | 27   | 340 1349 | 325   | 3    | 347 126 8 | 303   | 8    |
| 340 0935 | 334   | 101  | 340 1349 | 327   | 3    | 347 126 8 | 305   | 8    |
| 340 0937 | 330   | 14   | 340 1350 | 325   | 4    | 347 126 9 | 304   | 43   |

| TEILE-NR | SEITE | BILD |
|----------|-------|------|
| 347 1269 | 306   | 45   |
| 347 1270 | 303   | 26   |
| 347 1270 | 305   | 26   |
| 347 1291 | 292   | 235  |
| 347 1291 | 297   | 235  |
| 347 1292 | 292   | 151  |
| 347 1292 | 297   | 151  |
| 347 1298 | 292   | 126  |
| 347 1298 | 296   | 126  |
| 347 1299 | 292   | 128  |
| 347 1299 | 296   | 128  |
| 347 1301 | 292   | 130  |
| 347 1301 | 297   | 130  |
| 347 1303 | 292   | 131  |
| 347 1304 | 292   | 133  |
| 347 1304 | 297   | 133  |
| 347 1305 | 293   | 283  |
| 347 1305 | 298   | 292  |
| 347 1306 | 293   | 289  |
| 347 1306 | 298   | 296  |
| 347 1307 | 292   | 138  |
| 347 1307 | 297   | 138  |
| 347 4284 | 275   | 25   |
| 347 4299 | 292   | 129  |
| 347 4299 | 297   | 129  |
| 347 5079 | 263   | 17   |
| 347 5234 | 292   | 132  |
| 347 5234 | 297   | 132  |

TEILE-NR SEITE BILD

TEILE-NR SEITE BILD



Remarks

|         |   |           |
|---------|---|-----------|
| B 001 = | From axle No.   |           |
| B 002 = | From axle No. ....  | item      |
| B 003 = | From chassis No.  |           |
| B 004 = | From chassis No. ....   | item      |
| B 005 = | From gearbox No.  |           |
| B 006 = | From gearbox No. ....   | item      |
| B 007 = | From engine ser.No.   |           |
| B 008 = | From engine ser.No. ....  | see chart |
| B 009 = | Four-wheel drive  |           |
| B 010 = | Amperes   |           |
| B 011 = | Design  |           |
| B 012 = | Exhaust upwards   |           |
| B 013 = | External  |           |
| B 014 = | Outer dia.  |           |
| B 015 = | Old item No.  |           |
| B 025 = | Up to axle No.  |           |
| B 026 = | Up to axle No.  | item      |
| B 027 = | Up to chassis No.   |           |
| B 028 = | Up to chassis No. ....  | item      |
| B 029 = | Up to gearbox No.   |           |
| B 030 = | Up to gearbox No. ....  | item      |
| B 031 = | Up to engine ser.No.  |           |
| B 032 = | Up to engine ser.No. ....   | see chart |
| B 033 = | For design with blinker light   |           |
| B 034 = | For design with two-speed PTO shaft   |           |
| B 035 = | For design with short guide rail  |           |
| B 036 = | For design with stand. dual clutch  |           |
| B 037 = | For design with IPTO dual clutch  |           |
| B 038 = | For design with tank level indicator  |           |
| B 039 = | For design with ground speed PTO shaft  |           |
| B 040 = | With retractable steering wheel, w/o three-point linkage, w/o pivoted drawbar |           |
| B 041 = | For intitial replacement item ... to be supplied                              |           |
| B 042 = | For initial replacement supply item ... up to chassis No. ....                |           |
| B 043 = | For hydr. steering  |           |
| B 044 = | For hydrostatic steering  |           |

- B 045 = With headlamps, top
- B 046 = With headlamps, outer
- B 047 = For version with item .....
- B 048 = For version without item .....
- B 049 = On Type ....., only for version with differential
- B 050 = Consisting of item .....
- B 060 = Canada design
- B 061 = Illustration
- B 062 = German
- B 063 = Diameter
- B 064 = Double
- B 070 = Single
- B 071 = English
- B 072 = Spare part No.
- B 073 = Use up stock first
- B 074 = Replacement for item .....
- B 075 = Replaced by item .....
- B 076 = For single parts see item .....
- B 079 = for mechanical and hydrostatic steering systems
- B 080 = French
- B 081 = For air intake from above
- B 082 = For standard exhaust system and head lights
- B 083 = For exhaust upwards and standard head lights
- B 084 = For design with 1 KHD interm. control unit and 1 Westinghouse flange-type unit
- B 085 = For design w. 2 interm. units and 1 KHD terminal unit
- B 086 = For design w. 1 KHD interm. unit, 1 adapter plate, 1 Westinghouse interm. unit and 1 Westinghouse flange-type unit
- B 087 = For design w. 2 KHD interm. units 1 adapter plate and 1 Westinghouse flange-type unit
- B 088 = For design w. 2 KHD interm. units and 1 term.plate or 1 KHD interm. unit and 1 term.plate
- B 089 = For design w. 1 KHD terminal unit or 1 KHD interm. unit and 1 term. plate
- B 090 = For design w. 1 adapter plate and 1 Westinghouse flange-type unit
- B 091 = For design w. 1 adapter plate, 1 Westinghouse interm. unit and 1 Westinghouse flange-type unit
- B 092 = For design with hydr. lift
- B 093 = For design w/o hydr. lift
- B 094 = For tyres

- B 095 = For twin filament bulb
- B 096 = For brake pedal
- B 097 = For twin filter
- B 098 = For dual clutch
- B 099 = For alternator
- B 100 = For three-point linkage
- B 101 = For differeential lock
- B 102 = For single filter
- B 103 = For gas pedal
- B 104 = For housing cover
- B 105 = For dynamo
- B 106 = Hydr. steering
- B 107 = For cabin
- B 108 = For clutch
- B 109 = For creep gear design
- B 110 = For engine hood w/o head fights
- B 111 = For windscreen wiper
- B 112 = For head light
- B 113 = For synchronized transmission
- B 114 = For PTO shaft
- B 115 = For pivoted drawbar
- B 116 = For charging control
- B 117 = For oil pressure control
- B 118 = For filter control
- B 119 = For main beam control
- B 120 = Temperature indicator
- B 121 = For air blower
- B 122 = For trailer blinker
- B 123 = For tractor blinker
- B 124 = For head lamp, outer
- B 125 = For longhole
- B 126 = For version with 1 KHD intermediate controlunit and 1 adapter plate
- B 127 = Chassis No. like item .....
- B 128 = For final drive
- B 129 = For telescopic axle
- B 130 = For standard axle

- B 131 = For standard exhaust and head lamps, intake at front
- B 132 = For exhaust and intake stack, standard head lamp
- B 133 = For ordinary TPO-shaft
- B 134 = For ground-speed PTO-shaft
- B 135 = For trailer socket
- B 136 = For work lamp
- B 137 = For number plate
- B 138 = For mechanical and hydro-steering system
- B 139 = For Dry-type Air Cleaner
- B 140 = For Oil Bath Air Cleaner
- B 141 = Gear
- B 142 = On transmission end
- B 143 = Large
- B 144 = Assembly
- B 145 = Yellow
- B 150 = Rear
- B 151 = Rear, LH
- B 152 = Rear, RH
- B 153 = Dutch
- B 154 = Hydro-actuation
- B 161 = Inside
- B 162 = Inner dia.
- B 163 = Italian
- B 171 = Category
- B 172 = Kilogram
- B 173 = Mudguard, rear
- B 174 = Mudguard, rear LH
- B 175 = Mudguard, rear RH
- B 176 = Mudguard, front
- B 177 = Mudguard, front LH
- B 178 = Mudguard, front RH
- B 179 = Creep gear
- B 180 = Cubic centimeter
- B 181 = Cubic decimeter
- B 182 = short
- B 183 = Hydraulic Lift-Hydro-Steering System
- B 190 = Long
- B 191 = Slow
- B 192 = Light
- B 193 = Specification

- B 194 = Left half
- B 195 = LH
- B 196 = LH thread
- B 197 = LH cpl.
- B 198 = Left and right
- B 199 = Litre
- B 204 = Available by the meter
- B 205 = With adapter plate
- B 206 = With flange-type unit
- B 207 = With trailer socket
- B 208 = With starting lock
- B 209 = With external head light
- B 210 = With crank
- B 211 = With item .....
- B 212 = With two-speed PTO shaft
- B 213 = With PTO shaft
- B 214 = Millimeter
- B 215 = Middle
- B 216 = On engine end
- B 217 = Middle, left
- B 218 = Middle, right
- B 219 = With blinker lamp, without fuel level gauge
- B 220 = With angle plate
- B 221 = With spigot
- B 222 = With groove
- B 223 = With blinker lamp
- B 224 = As required
- B 225 = Cancel after using up
- B 226 = Standard
- B 227 = Standard wheel
- B 228 = Only for semi-mounted plough
- B 229 = Only for perm. dimmer light
- B 230 = Only for head light flasher
- B 231 = Only for plantation tractor
- B 232 = Only available with item .....
- B 233 = Use only with item .....
- B 234 = Only for standard clutch
- B 235 = Only for dual clutch
- B 236 = Only in case of short guide rail

- B 241 = Oil tank - Hydro-steering system
- B 242 = At top
- B 243 = At top, LH
- B 244 = At top, RH
- B 245 = Upper part
- B 246 = Or item .....
- B 247 = w/o item .....
- B 248 = w/o cabin
- B 249 = w/o mowing attachment
- B 250 = Without blinker lamp, without tank level gauge
- B 251 = Without blinker lamp
- B 252 = Top part - for cab
- B 253 = Without headlamp, exhaust normal
- B 254 = Without headlamp, exhaust upwards
- B 255 = Without headlamp, exhaust normal, intake above
- B 256 = Without headlamp, exhaust and intake above
- B 257 = Plantation tractor
- B 258 = Item .....
- B 265 = Wheelbase
- B 266 = Right hall
- B 267 = RH
- B 268 = RH, cpl.
- B 269 = Repair set
- B 270 = Reverse
- B 271 = Reverse gear
- B 272 = Round
- B 273 = Round, diameter
- B 281 = Collective package
- B 282 = Set
- B 283 = Self-locking
- B 284 = See illustration
- B 285 = See item
- B 286 = See chart No.
- B 287 = See description
- B 288 = Tractor
- B 289 = Narrow gauge
- B 290 = High-speed
- B 291 = High-speed gear
- B 292 = Heavy
- B 293 = Tail/stop/blinker/number plate lights

- B 294 = Tail/stop/blinker lights
- B 295 = Tail/stop/number plate lights
- B 296 = Tail/stop lights
- B 297 = Synchronous
- B 298 = Spanish
- B 299 = Adjustable-gauge wheel
- B 300 = Headlamp, right
- B 301 = Headlamp, left
- B 302 = Headlamp, top
- B 303 = Tubeless
- B 310 = Chart No.
- B 311 = Part
- B 312 = Part No.
- B 313 = Part number list sheet
- B 314 = Telescopic, unsprung
- B 321 = Oversize see item .....
- B 322 = Rev. per min.
- B 323 = Independent
- B 324 = At bottom
- B 325 = At bottom, LH
- B 326 = At bottom, RH
- B 327 = Undersize see item .....
- B 328 = Unsprung
- B 335 = Version
- B 336 = Use with item .....
- B 337 = Complete
- B 338 = Complete, LH
- B 339 = Complete, RH
- B 340 = Complete, at top
- B 341 = Complete, at bottom
- B 342 = Complete, rear
- B 343 = Complete, front
- B 344 = Fully synchronized
- B 345 = Fully synchronized with two-speed PTO shaft
- B 346 = Front
- B 347 = Complete with item .....
- B 348 = Front, left
- B 349 = Front, right
- B 350 = REINFORCED

- B 355 = Item ..... at option
- B 356 = Westinghouse
- B 357 = Water-proof
- B 365 = No. of teeth
- B 366 = Together with item ....
- B 367 = To item .....
- B 380 = With front drive
- B 381 = With tube
- B 382 = Mesh-width
- B 383 = Without front drive



## Observations

- B 001 = A partir de l'essieu n°
- B 002 = A partir de l'essieu n° ..... poste
- B 003 = A partir du châssis n°
- B 004 = A partir du châssis n° ..... poste
- B 005 = A partir de la boîte de vitesses n°
- B 006 = A partir de la boîte de vitesses n° poste
- B 007 = A partir du moteur n°
- B 008 = A partir du moteur n° voir planche
- B 009 = Exécution toutes roues motrices
- B 010 = Ampères
- B 011 = Exécution
- B 012 = Echappement vers le haut
- B 013 = Extérieur (e) (s) (es)
- B 014 = Diamètre extérieur
- B 015 = Ancien poste n°
- B 025 = Jusqu'à l'essieu n°
- B 026 = Jusqu'à l'essieu n° poste
- B 027 = Jusqu'au châssis n°
- B 028 = Jusqu'au châssis n° poste
- B 029 = Jusqu'à la boîte de vitesses n°
- B 030 = Jusqu'à la boîte de vitesses n° poste
- B 031 = Jusqu'au moteur n°
- B 032 = Jusqu'au moteur n°
- B 033 = En cas d'exécution avec clignotant
- B 034 = En cas d'exécution avec prise de force à 2 régimes
- B 035 = En cas d'exécution avec barre d'attelage courte
- B 036 = En cas d'exécution avec embrayage pour prise de force indépendante
- B 037 = En cas d'exécution avec embrayage pour prise de force autonome
- B 038 = En cas d'exécution avec indication du niveau du réservoir
- B 039 = En cas d'exécution avec de force proportionnelle
- B 040 = Sur bras inf. rétractible sans trois points, sans barre oscillante
- B 041 = Lors du premier remplacement fournir également poste .....
- B 042 = Lors du premier remplacement fournir également poste ..... jusqu'au châssis n° .....

- B 043 = Pour direction hydro-assistée
- B 044 = Pour direction hydrostatique
- B 045 = Pour phare en haut
- B 046 = Pour phare à l'extérieur
- B 047 = Pour exécution avec rep. ....
- B 048 = Pour exécution sans rep. ....
- B 049 = Pour type ....., seulement pour exécution avec différentiel
- B 050 = Comprenant rep. ....
- B 060 = Version Canada
- B 061 = Représentation
- B 062 = Allemand
- B 063 = Diamètre
- B 064 = Double
- B 070 = Simple
- B 071 = Anglais
- B 072 = Piece de rechange n°
- B 073 = Utiliser d'abord le stock
- B 074 = Remplacement pour rép. ....
- B 075 = Remplacé par rep. ....
- B 076 = Pièces détachées voir rep. ....
- B 079 = p. Direction mécanique et Hydrostatique
- B 080 = Français
- B 081 = Pour aspiration par le haut
- B 082 = Pour échappement et phares standard
- B 083 = Pour échappement vers le haut et phares standard
- B 084 = Pour exécution avec 1 distributeur intermédiaire KHD et un distributeur bridé Westinghouse
- B 085 = Pour exécution avec 2 distributeurs intermédiaires et 1 distributeur terminal KHD
- B 086 = Pour exécution avec 1 distributeur intermédiaire KHD, 1 plaque d'adaptation, 1 distributeur intermédiaire Westinghouse et 1 distributeur bridé Westinghouse
- B 087 = Pour exécution avec 2 distributeurs intermédiaires KHD, 1 plaque d'adaptation et 1 distributeur bridé Westinghouse
- B 088 = Pour exécution avec 2 distributeurs intermédiaires KHD et une plaque d'extrémité ou 1 distributeur intermédiaire KHD et 1 plaque d'extrémité
- B 089 = Pour exécution avec 1 distributeur terminal KHD ou 1 distributeur intermédiaire KHD et 1 plaque d'extrémité
- B 090 = Pour exécution avec 1 plaque d'adaptation et 1 distributeur bridé Westinghouse

- B 091 = Pour exécution avec 1 plaque d'adaptation, 1 distributeur intermédiaire Westinghouse et 1 distributeur bride Westinghouse
- B 092 = Pour exécution avec bloc de relevage
- B 093 = Pour exécution sans bloc de relevage
- B 094 = Pour pneumatiques
- B 095 = Pour ampoule phare-code
- B 096 = Pour pédale de frein
- B 097 = Pour filtre double
- B 098 = Pour double accouplement
- B 099 = Pour alternateur
- B 100 = Pour accouplement trois points
- B 101 = Pour blocage de différentiel
- B 102 = Pour filtre simple
- B 103 = Pour pédale d'accélération
- B 104 = Pour couvercle de carter
- B 105 = Pour dynamo
- B 106 = Direction hydro-assistée
- B 107 = Pour cabine
- B 108 = Pour accouplement
- B 109 = Pour exécution avec vitesse ultra-lente
- B 110 = Pour capot moteur sans phares
- B 111 = Pour essuie-glace
- B 112 = Pour phares
- B 113 = Pour exécution synchrone
- B 114 = Pour prise de force
- B 115 = Pour barre oscillante
- B 116 = Pour controle de charge
- B 117 = Pour controle de pression d'huile
- B 118 = Pour controle de filtre
- B 119 = Pour controle lumière route
- B 120 = Indication de température
- B 121 = Pour soufflante
- B 122 = Pour clignoteur de remorque
- B 123 = Pour clignoteur de tracteur
- B 124 = Pour phare extérieur
- B 125 = Pour trou oblong
- B 126 = Pour exécution avec 1 distributeur intermédiaire KHD et 1 plaque d'adaptation

- B 127 = No. de chassis comme pour rep. ....
- B 128 = Pour renvoi
- B 129 = Pour essieu télescopique
- B 130 = Pour essieu normal
- B 131 = Pour échappement et phares normaux, aspiration à l'avant
- B 132 = Pour échappement et aspiration en haut, phares normaux
- B 133 = Pour prise de force normale
- B 134 = Pour prise de force proportionnelle
- B 135 = Pour prise de courant de remorque
- B 136 = Pour phare de travail
- B 137 = Pour plaque d'immatriculation
- B 138 = Pour direction mécanique et hydro-assistée
- B 139 = Pour Epurateur d'air du type sec
- B 140 = Pour Epurateur d'air à bain d'huile
- B 141 = Vitesse
- B 142 = Coté boîte de vitesses
- B 143 = Grand (e)
- B 144 = Groupe
- B 145 = Jaune
- B 150 = Arrière
- B 151 = Arrière gauche
- B 152 = Arrière droit (e)
- B 153 = Hollandaes
- B 154 = Actionnement hydraulique
- B 161 = à l'intérieur / intérieur
- B 162 = Diamètre intérieur
- B 163 = Italien
- B 171 = Catégorie
- B 172 = Kilogrammes
- B 173 = Aile arrière
- B 174 = Aile arrière gauche
- B 175 = Aile arrière droite
- B 176 = Aile avant
- B 177 = Aile avant gauche
- B 178 = Aile avant droite
- B 179 = Vitesse ultra-lente
- B 180 = Centimètres cube  $\text{cm}^3$
- B 181 = Décimètres cube  $\text{dm}^3$
- B 182 = Court(e) (s)
- B 183 = Bloec de relevage-direction hydroassistée
- B 190 = Long(ue) (s)
- B 191 = Lent(e)
- B 192 = Léger (légère) (s)

- B 193 = Etendue de fourniture
- B 194 = Moitié gauche
- B 195 = Gauche
- B 196 = Filet gauche
- B 197 = Gauche, compl.
- B 198 = A gauche et à droite
- B 199 = Litre
- B 204 = au mètre
- B 205 = Avec plaque d'adaptation
- B 206 = Avec distributeur bridé
- B 207 = Avec prise de courant remorque
- B 208 = Avec blocage de démarrage
- B 209 = Avec phares extérieurs
- B 210 = Avec manivelle
- B 211 = Avec poste .....
- B 212 = Avec prise de force à deux régimes
- B 213 = Avec prise de force
- B 214 = Millimètres
- B 215 = Milieu / centre
- B 216 = Coté moteur
- B 217 = Centre gauche
- B 218 = Centre droit
- B 219 = Avec clignoteur, sans indicateur de niveau de réservoir
- B 220 = Avec équerre
- B 221 = Avec tenon
- B 222 = Avec rainure
- B 223 = Avec clignoteur
- B 224 = Selon besoins
- B 225 = Supprimer après épuisement des stocks
- B 226 = Standard / normal
- B 227 = Roue standard
- B 228 = Seulement pour charrue semi-portée
- B 229 = Seulement pour code permanent
- B 230 = Seulement pour avertisseur lumineux
- B 231 = Seulement pour tracteur à voie étroite
- B 232 = Seulement livrable avec poste .....
- B 233 = A utiliser seulement avec poste .....

- B 234 = Seulement pour accouplement a simple effet
- B 235 = Seulement pour accouplement a double effet
- B 236 = Seulement pour barre de guidage courte
- B 241 = Tanque de aceite - servo-direccion hidraulica
- B 242 = En haut / supérieur
- B 243 = En haut et a gauche / supérieur gauche
- B 244 = En haut et a droite / supérieur droit(e)
- B 245 = Partie supérieure
- B 246 = ou poste .....
- B 247 = sans poste .....
- B 248 = sans cabine
- B 249 = sans barre faucheuse
- B 250 = Sans clignoteur, sans indicateur de niveau du réservoir
- B 251 = Sans clignoteur
- B 252 = Partie supérieure - pour cabine
- B 253 = Sans phare, échappement normal
- B 254 = Sans phare, échappement vers le haut
- B 255 = Sans phare, échappement normal, aspiration en haut
- B 256 = Sans phare, échappement et aspiration en haut
- B 257 = Tracteur a voie étroite
- B 258 = Poste .....
- B 265 = Empattement
- B 266 = Moitié droite
- B 267 = Droite(e) / a droite
- B 268 = Droite(e) compl.
- B 269 = Lot réparation
- B 270 = Arrière
- B 271 = Vitesse arrière
- B 272 = Rond
- B 273 = Rond, diamètre  $\emptyset$
- B 281 = Emballage collectif
- B 282 = Jeu
- B 283 = Auto-freinant
- B 284 = Voir figure
- B 285 = Voir poste
- B 286 = Voir planche n°
- B 287 = Voir explications
- B 288 = Tracteur
- B 289 = Voie étroite

- B 290 = Rapide
- B 291 = Vitesse rapide
- B 292 = Lourd(e)
- B 293 = Feu combiné AR-stop-clignotant-de plaque d'immatriculation
- B 294 = Feu combiné AR-stop-clignotant
- B 295 = Feu combiné AR-stop-de plaque d'immatriculation
- B 296 = Feu combiné AR-stop
- B 297 = Synchrone
- B 298 = Espagnol
- B 299 = Roue à réglage de voie
- B 300 = Phare - droit
- B 301 = Phare - gauche
- B 302 = Phare - en haut
- B 303 = Sans chambre à air
- B 310 = Planche n°
- B 311 = Pièce
- B 312 = Pièce n°
- B 313 = Feuille de liste de numéros de pièce
- B 314 = Télescopique - sans suspension
- B 321 = Cote surdimensionnée voir poste .....
- B 322 = Tours/minute
- B 323 = Indépendant
- B 324 = en bas / inférieur
- B 325 = Inférieur gauche
- B 326 = Inférieur droit(e)
- B 327 = Cote sousdimensionnée voir poste .....
- B 328 = Sans suspension
- B 335 = Variante
- B 336 = Utiliser avec poste .....
- B 337 = Compl.
- B 338 = Compl., gauche
- B 339 = Compl., droit(e)
- B 340 = Compl., supérieur(e)
- B 341 = Compl., inférieur(e)
- B 342 = Compl., arrière
- B 343 = Compl., avant
- B 344 = Entièrement synchronisé
- B 345 = Entièrement synchronisé avec prise de force à 2 régimes

- B 346 = Avant
- B 347 = Compl. avec rep. ....
- B 348 = Avant - a gauche
- B 349 = Avant - a droite
- B 350 = RENFORCE
- B 355 = Au choix poste .....
- B 356 = Westinghouse
- B 357 = Etanche a l'eau
- B 365 = Nombre de dents
- B 366 = Ensemble avec poste .....
- B 367 = Pour poste .....
- B 380 = A traction avant
- B 381 = Avec tuyau
- B 382 = Ouverture de maille
- B 383 = Sans essieu avant moteur



## O b s e r v a c i o n e s

- B 001 = A partir eje No.
- B 002 = A partir eje No. Pos.
- B 003 = A partir chasis No.
- B 004 = A partir chasis No. Pos.
- B 005 = A partir transmisión No.
- B 006 = A partir transmisión No. Pos.
- B 007 = A partir motor No.
- B 008 = A partir motor No. véase grabado
- B 009 = Versión de tracción universal
- B 010 = Amperios
- B 011 = Ejecución
- B 012 = Escape hacia arriba
- B 013 = Exterior
- B 014 = Diámetro exterior
- B 015 = Antiguo No. de Pos.
- B 025 = Hasta eje No.
- B 026 = Hasta eje No. Pos.
- B 027 = Hasta chasis No.
- B 028 = Hasta chasis No. Pos.
- B 029 = Hasta transmisión No.
- B 030 = Hasta transmisión No. Pos.
- B 031 = Hasta motor No.
- B 032 = Hasta motor No. véase grabado
- B 033 = En la versión con intermitentes
- B 034 = En la versión con toma de fuerza "Duo"
- B 035 = En la versión con carril de guía corto
- B 036 = En la versión con embrague doble dependiente del motor
- B 037 = En la versión con embrague doble independiente
- B 038 = En la versión con indicador de nivel del tanque
- B 039 = En la versión con toma de fuerza dependiente del avance
- B 040 = Existiendo guías telescópicas, sin acoplamiento en tres puntos, sind péndulo de tracción
- B 041 = En el primer suministro de repuestos acompañar Pos. ....
- B 042 = En el primer suministro de repuestos hasta chasis No. ....  
acompañar Pos. ....
- B 043 = Existiendo servo-dirección hidráulica
- B 044 = Existiendo dirección hidrostática

- B 045 = Existiendo faros superiores
- B 046 = Existiendo faros exteriores
- B 047 = En la ejecución con Pos. ....
- B 048 = En la ejecución sin Pos. ....
- B 049 = En tipo ..... sólo para ejecución con diferencial
- B 050 = Consistiendo en Pos. ....
- B 060 = Versión "Canada"
- B 061 = Representación
- B 062 = Alemán
- B 063 = Diámetro
- B 064 = Doble
- B 070 = Simple
- B 071 = Inglés
- B 072 = Lista de repuestos No.
- B 073 = Agotar primero existencias en almacén
- B 074 = Sustituye a Pos. ....
- B 075 = Sustitución por Pos. ....
- B 076 = Partes individuales véase Pos. ....
- B 079 = p. Direccion mecanica y hidrostática
- B 080 = Francés
- B 081 = Para aspiración desde arriba
- B 082 = Para escape y faros versión normal
- B 083 = Para escape hacia arriba y faros versión normal
- B 084 = Para versión con un aparato de mando intermedio KHD y un aparato de mando abridado Westinghouse
- B 085 = Para versión con dos aparatos de mando intermedio y un aparato de mando final KHD
- B 086 = Para versión con un aparato de mando intermedio KHD, una placa de adaptación, un aparato de mando intermedio Westinghouse y un aparato de mando abridado Westinghouse
- B 087 = Para versión con dos aparatos de mando intermedios KHD, una placa de adaptación y un aparato de mando abridado Westinghouse
- B 088 = Para versión con dos aparatos de mando intermedios KHD y una placa final, o un aparato de mando intermedio KHD y una placa final
- B 089 = Para versión con un aparato de mando final KHD o un aparato de mando intermedio KHD y una placa final
- B 090 = Para versión con una placa de adaptación y un aparato de mando abridado Westinghouse
- B 091 = Para versión con una placa de adaptación, un aparato de mando intermedio Westinghouse y un aparato de mando abridado Westinghouse

- B 092 = Para versión con elevador hidráulico
- B 093 = Para versión sin elevador hidráulico
- B 094 = Para neumáticos
- B 095 = Para lámpara Bilux
- B 096 = Para pedal de freno
- B 097 = Para filtro doble
- B 098 = Para embrague doble
- B 099 = Para generatriz de corriente trifásica
- B 100 = Para acoplamiento en tres puntos
- B 101 = Para bloqueo de diferencial
- B 102 = Para filtro simple
- B 103 = Para pedal acelerador
- B 104 = Para tapa de caja
- B 105 = Para generatriz de corriente continua
- B 106 = Servo-dirección hidráulica
- B 107 = Para cabina
- B 108 = Para embrague
- B 109 = Para versión con marchas ultralentas
- B 110 = Para capot de motor sin faros incorporados
- S 111 = Para limpia-parabrisas
- B 112 = Para faros
- B 113 = Para versión sincronizada
- B 114 = Para árbol toma de fuerza
- B 115 = Para péndulo de tracción
- B 116 = Para control de carga
- B 117 = Para control de presión de aceite
- B 118 = Para control de filtro
- B 119 = Para control para luz de carretera
- B 120 = Indicador de temperatura
- B 121 = Para ventilador
- B 122 = Para luces intermitentes para remolques
- B 123 = Para luces intermitentes para tractor
- B 124 = Para faros exteriores
- B 125 = Para orificio alargado
- B 126 = Para ejecución con 1 aparato de mando intermedio KHD y 1 placa intermedia
- B 127 = Chasis No. como Pos. ....
- B 128 = Para transmisión
- B 129 = Para eje telescópico

- B 130 = Para eje normal
- B 131 = Para escape y faros normales, admisión delante
- B 132 = Para escape y admisión arriba, faros normales
- B 133 = Para árbol toma de fuerza dependiente del embrague
- B 134 = Para árbol toma de fuerza dependiente de la rodadura
- B 135 = Para caja de enchufe para remolque
- B 136 = Para faros de trabajo
- B 137 = Para matricula
- B 138 = Para dirección mecánica y servodirección hidráulica
- B 139 = Para Filtro de aire en seco
- B 140 = Para Filtro de aire en bano de aceite
- B 141 = Marcha
- B 142 = Lado del cambio
- B 143 = Grande
- B 144 = Grupo
- B 145 = Amarillo
- B 150 = Atrás
- B 151 = Atrás-izquierda
- B 152 = Atrás-derecha
- B 153 = Holandés
- B 154 = Accionamiento hidráulico
- B 161 = Interior
- B 162 = Diámetro interior
- B 163 = Italiano
- B 171 = Categoría
- B 172 = Kilogramos
- B 173 = Guardabárros-atrás
- B 174 = Guardabarros-atrás-izquierda
- B 175 = Guardabarros-atrás-derecha
- B 176 = Guardabarros-delante
- B 177 = Guardabarros-delante-izquierda
- B 178 = Guardabarros-delante-derecha
- B 179 = Marcha ultralenta
- B 180 = Centímetros cúbicos (cm<sup>3</sup>)
- B 181 = Decímetros cúbicos (dm<sup>3</sup>)
- B 182 = Corto
- B 183 = Elevador hidráulico-servo-direc
  
- B 190 = Largo
- B 191 = Lento
- B 192 = Liviano
- B 193 = Volumen de suministro

- B 194 = Mitad izquierda
- B 195 = Izquierda
- B 196 = Rosca paso a izquierda
- B 197 = Izquierda, compl.
- B 198 = Izquierda y derecha
- B 199 = Litros
- B 204 = Por metros
- B 205 = Con placa de adaptación
- B 206 = Con aparato de mando abridado
- B 207 = Con caja de enchufe para remolque
- B 208 = Con bloqueo contra arranque
- B 209 = Con faros exteriores
- B 210 = Con manivela
- B 211 = Con Pos. ....
- B 212 = Con toma de fuerza "Duo"
- B 213 = Con árbol toma de fuerza
- B 214 = Milímetros
- B 215 = Control
- B 216 = Lado motor
- B 217 = Centro - izquierda
- B 218 = Centro - derecha
- B 219 = Con intermitentes, sin indicador para contenido del tanque
- B 220 = Con ángulo
- B 221 = Con munón
- B 222 = Con ranura
- B 223 = Con intermitentes
- B 224 = Según necesidad
- B 225 = Tachar después de consumirse
- B 226 = Normal
- B 227 = Rueda normal
- B 228 = Sólo para arado con tercer punto móvil
- B 229 = Sólo para constante luz de cruce
- B 230 = Sólo para bocina luminosa
- B 231 = Sólo para tractor de cultivo
- B 232 = Sólo suministrable con Pos. ....
- B 233 = Sólo utilizable con Pos. ....
- B 234 = Sólo existiendo embrague simple

- B 235 = Sólo existiendo embrague doble
- B 241 = Reservoir d'huile - direction hydro-assistée
- B 242 = Arriba
- B 243 = Arriba-izquierda
- B 244 = Arriba-derecha
- B 245 = Parte superior
- B 246 = O Pos. ....
- B 247 = Sin Pos. ....
- B 248 = Sin cabina
- B 249 = Sin segadora
- B 250 = Sin intermitentes, sin indicador para contenido del tanque
- B 251 = Sin intermitentes
- B 252 = Parte superior - cabina
- B 253 = Sin faros, escape normal
- B 254 = Sin faros, escape hacia arriba
- B 255 = Sin faros, escape normal admisión desde arriba
- B 256 = Sin faros, escape y admisión arriba
- B 257 = Tractor de cultivo
- B 258 = Fos. ....
- B 265 = Distancia entre ejes
- B 266 = Mitad derecha
- B 267 = Derecha
- B 268 = Derecha, compl.
- B 269 = Lote de reparación
- B 270 = Atrás
- B 271 = Marcha atrás
- B 272 = Redondo
- B 273 = Redondo, diámetro ( $\emptyset$ )
- B 281 = Paquete colectivo
- B 282 = Lote
- B 283 = Autoafianzador
- B 284 = Véase Fig.
- B 285 = Véase Pos.
- B 286 = Véase grabado No.
- B 287 = Véase aclaración
- B 288 = Tractor

- B 289 = Via estrecha
- B 290 = Rápido
- B 291 = Marcha rápida
- B 292 = Pesado
- B 293 = Luz piloto con luz de frenado, intermitente y alumbrado de matrícula
- B 294 = Luz piloto con luz de alumbrado e intermitente
- B 295 = Luz piloto con luz de frenado y alumbrado de matrícula
- B 296 = Luz piloto con luz de frenado
- B 297 = Sincronizado
- B 298 = Espanol
- B 299 = Rueda de modificación de ancho de rodada
- B 300 = Faro - derecha
- B 301 = Faro - izquierda
- B 302 = Faros - superiores
- B 303 = Sin cámara
- B 310 = Grabado No.
- B 311 = Pieza
- B 312 = Pieza No.
- B 313 = Hoja de lista de Nos. de piezas
- B 314 = Telescópico - sin suspensión elástica
- B 321 = Medida de desgaste véase Pos. ....
- B 322 = Revoluciones por minuto
- B 323 = Independiente
- B 324 = Abajo
- B 325 = Abajo-izquierda
- B 326 = Abajo-derecha
- B 327 = Medida de desgaste véase Pos. ....
- B 328 = Sin suspensión elástica
- B 335 = Variante
- B 336 = Utilizar con Pos. ....
- B 337 = Completo
- B 338 = Completo, izquierda
- B 339 = Completo, derecha
- B 340 = Completo, arriba
- B 341 = Completo, abajo
- B 342 = Completo, atrás
- B 343 = Completo, delante

- B 344 = Con sincronización total
- B 345 = Con sincronización total, con toma de fuerza "Duo"
- B 346 = Delante
- B 347 = Compl. con Pos.
- B 348 = Delante - izquierda
- B 349 = Delante - derecha
- B 350 = REFORZADO/A
- B 355 = Opcionalmente Pos. ....
- B 356 = Westinghouse
- B 357 = A Prueba de Agua
- B 365 = No. de dientes
- B 366 = Junto con Pos. ....
- B 367 = Para Pos. ....
- B 380 = Con propulsión delantera
- B 381 = Con tubo
- B 382 = Luz de malla
- B 383 = Sin propulsión delantera



Für diese Zeichnung behalten wir uns alle Rechte nach DIN 34 vor.

Die  Maße werden vom Besteller (Empfänger) besonders beachtet Maßzahlen in Klammern (76) gelten nicht für die Kontrolle.

Motorhaube

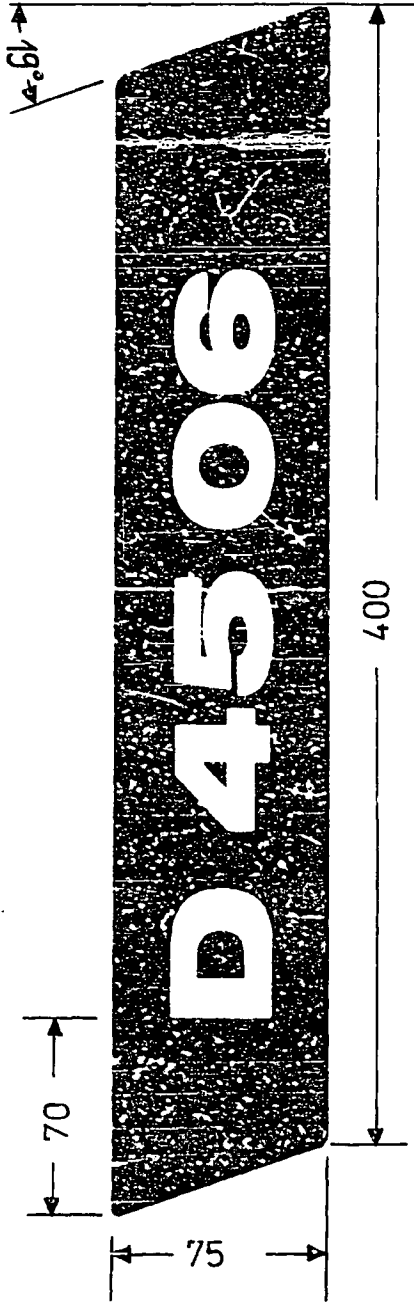

Ähnlichkeit-Schlüssel-Nr.

Angaben:

1. Alle Eckradien = 5 mm
2. Konstr. - Nr. 4314009 auf dem rückseitigen Schutzpapier gut lesbar angebracht
3. Folienfarbe: schwarzblau, RAL 5004; Schrift: silber, matt
4. Ausführung: selbstklebende Polyesterfolie nach Liefervorschrift 8025-02-6504
5. Bei Herstellung KHD-Vorlage verwenden

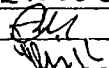
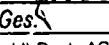
|                       |   |  |   |                            |
|-----------------------|---|--|---|----------------------------|
| Bauart<br><b>1004</b> | Freimaßtoleranzen<br>C, mittel<br>DIN 7168<br>Kanten graffrei | Oberflächen-<br>Kennzeichng.<br>nach<br>DIN 3142   | Maßstab<br><b>1 : 2,5</b>               | Gewicht                    |
|                       |   |  | Werkstoff<br>Rohteil-Nr.<br><b>S.O.</b> |                            |
|                       | Datum   | Name   | Benennung                               |                            |
|                       | Bearb. <b>15-5-77</b>   | <b>EHUNDS</b>  | <b>TYPSCHILD</b>                        |                            |
|                       | Gepr.   |       |   |                            |
|                       | Norm  |  |   |                            |
|                       | Abt. <b>SR</b>  | Ges.  |   |                            |
|                       | Klöckner-Humboldt-Deutz AG                                    |  | Nr.<br><b>4314009 EE 1004 -71</b>       | Blatt<br>von Bl.           |
| Zust.                 | Änderung  | Datum  | Name                                    | Urspr. <b>M 1002-00-13</b> |
|                       |   |  |   | Ers. für:                  |
|                       |   |  |   | Ers. durch:                |



Für diese Zeichnung behalten wir uns alle Rechte nach DIN 34 vor.  
 Die Maße werden vom Besteller (Empfänger) besonders beachtet. Maßzahlen in Klammern (76) gelten nicht für die Kontrolle.

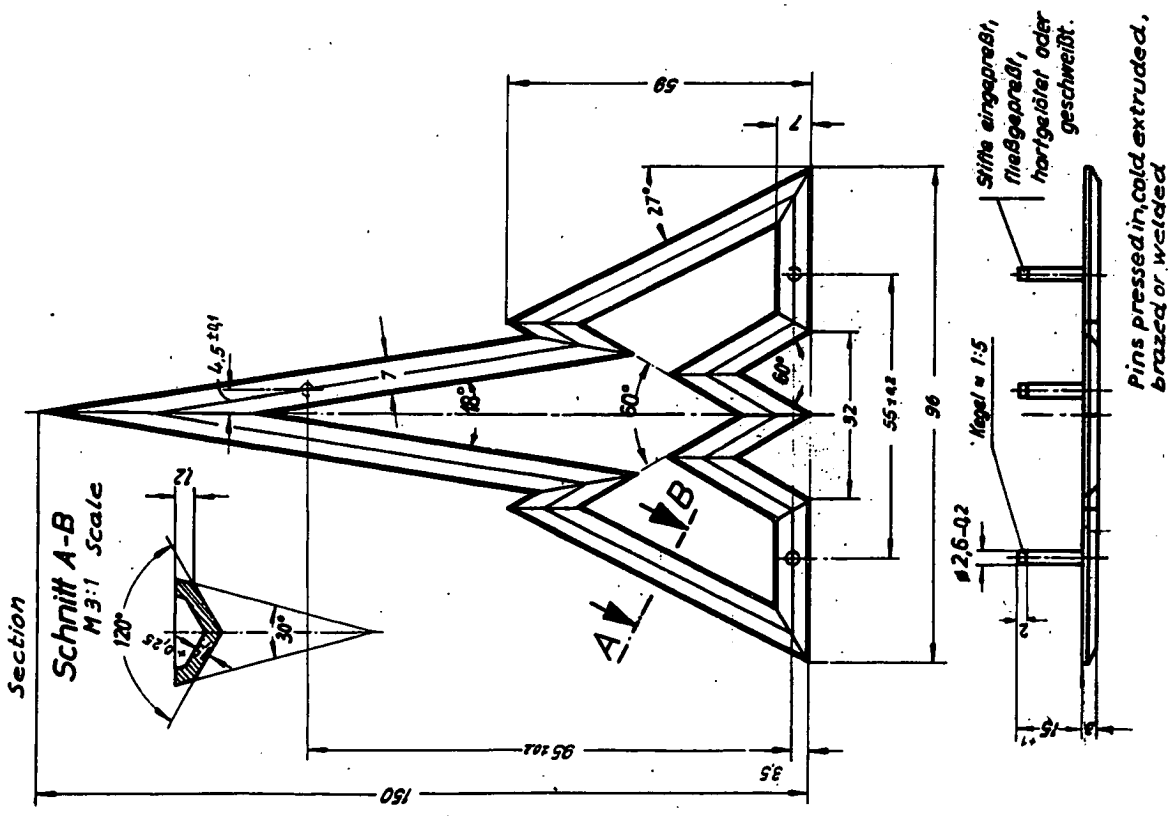

Einbrennlackierung  
 Farbe: schwarz RAL 9005 nach Lieferschrift 8025-01-9223  
 Stoved lacquering Colour: Black RAL 9005 as per instructions

(4315 A 9)

LI 33  
 LI 10  
 LI 13



|   |                                     |  |                               |
|---|-------------------------------------|--|-------------------------------|
| Bezeichnung<br><b>1001 bis 1009<br/>1013 / 1016</b> | Freischweisart<br>mitel<br>DIN 7160 | Überflächen<br>Reihe 2<br>DIN 314<br>gestrichelt | Material<br>3:1<br>Gewicht    |
|   | Beard<br>2.5-74                     | Stift<br>1001                                    | Werkstoff<br>Al 99.8 DIN 1712 |
|   | Norm<br>AM. AZN                     | Gez.<br>1001                                     | Rechenmaß<br>Rechenmaß        |
|   | Urspr.<br>M 1001-71-07              | KHD<br>KHD-Werkzeugmaschinen AG                  | Benennung<br>Trade mark       |
| Zust.   | Änderung                            | Datum  | Wartung                       |
|   |                                     |  | Firmenbildzeichen             |
|   |                                     |  | Nr.<br>121 4951 ED 8943 - 15  |
|   |                                     |  | Erz. durch:<br>von R.         |

|                       |  |  |  |
|-----------------------|--|--|--|
| Kundent-Schlüssel-Nr. |  |  |  |
|                       |  |  |  |

Archiv



Für diese Zeichnung behalten wir uns alle Rechte nach DIN 34 vor.  
Die Maße werden vom Besteller (Empfänger) besonders beachtet. Maßzahlen in Klammern (16) gelten nicht für die Kontrolle.

|  |  |  |  |  |
|--|--|--|--|--|
|  |  |  |  |  |
|  |  |  |  |  |
|  |  |  |  |  |
|  |  |  |  |  |

| Ähnlichkeit-Schlüssel-Nr. |  |  |  |
|---------------------------|--|--|--|
|                           |  |  |  |

Kotflügel hinten

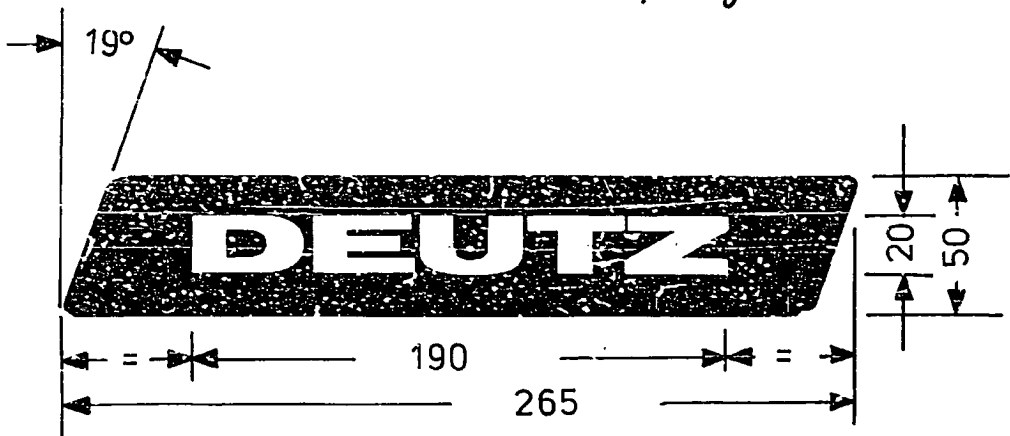

**Angaben:**

1. Alle Eckradien = 5 mm
2. Konstr.-Nr. 4311592 auf dem rückseitigen Schutzpapier gut lesbar angebracht
3. Folienfarbe: schwarzblau, RAL 5004; Schrift: silber, matt
4. Ausführung: selbstklebende Polyesterfolie nach Liefervorschrift 8025-02-6504
5. Bei Herstellung KHD-Vorlage verwenden
5. lors de la fabrication utiliser modèle KHD

Li 13  
Li 12

|   |  |  |  |                    |           |             |
|---|--|--|--|--------------------|-----------|-------------|
| Bauart 1002, 1003, 1004, 1005, 1006, 1009, 1016 | Freimaßtoleranzen<br>C mittel<br>DIN 7168<br>Kanten gratfrei | Oberflächen-<br>Kennzeichng.<br>nach<br>DIN 3142 | Maßstab 1:2,5  | Gewicht            |           |             |
|   | Datum  | Name   | Werkstoff  | Rohteil-Nr.        |           |             |
|   | Bearb. 18-8-77   | EHUNDIS  | S.O.   |                    |           |             |
|   | Gep.   | EM   | Benennung<br><b>Plaque à renseignement<br/>PRODUKTSCHILD<br/>conc. produit</b> |                    |           |             |
|   | Norm   | SM   |  |                    |           |             |
|   | Abt. SR  | Ges.   |  |                    |           |             |
|   | Klöckner-Humboldt-Deutz AG                                   |  | Nr.  | Blatt              |           |             |
|   |  |  | 4311592 EE 1002-71   | von Bl.            |           |             |
| Zust.   | Änderung   | Datum  | Name   | Urspr. H1002-71-02 | Ers. für: | Ers. durch: |



# MANITOU

Gültig ab Triebwerk No.

Effective from Transmission No.

Valable a partir de la Transmission No.

Valida a partir transmission No.

7542/0001

**Ersatzteil-Nummernliste**

**Spare Parts Nos. List**

**Liste des repères numériques  
des pièces de rechange**

**Lista de Nos. de repuestos**

**500 0653 1003-99**

Ersatzteil-Nummernliste  
Spare Parts/Nos. List  
Liste de n<sup>os</sup> de pièces de rechange  
Lista de Nos. de repuestos.

500 0653 1003-99

Diese Druckschrift ist für unseren Ersatzteildienst bestimmt und darf weder ganz noch auszugsweise weitergegeben oder zu anderen Zwecken, als denen sie dem Empfänger anvertraut wurde, benutzt werden.

This list is intended to be used solely for our Spare Parts Service and may not be distributed in part or whole, nor used for purposes other than for which it was issued to the receiver.

Cette brochure est destinée à notre service de fourniture des pièces de rechange. Son détenteur ne devra en aucun cas permettre à des tiers d'en pendre connaissance même partiellement ou l'utiliser à des fins autres que celles pour lesquelles elle lui a été confiée.

Esta lista está destinada a nuestro servicio de suministro de repuestos, no debiendo transmitirla su tenedor, total o parcialmente a terceros, ni emplearla en otros fines que para los que le ha sido confiada.

**Die Druckschrift bleibt unser Eigentum.**

**This book remains our property.**

**Cette brochure reste notre propriété.**

**Esta lista sigue siendo propiedad nuestra.**

**Klöckner-Humboldt-Deutz  
Aktiengesellschaft**

# MANITOU

Gültig ab Triewerk No.

Effective from Transmission No.

Valable a partir de la transmission No. 7542/0001

Valida a partir transmission No.

Ersatzteil-Nummernliste

Spare Parts Nos. List

Liste de n<sup>os</sup> de pièces de rechange

Lista de Nos. de repuestos

500 0653 1003-99

Klöckner-Humboldt-Deutz AG



**KHD**



ETK DEUTSCH  
01 TEIL VORDRINGLICH AUF LAGER HALTEN

ETK ENGLISH  
01 STOCK AS PRIORITY PART

ETK FRANCAIS  
01 Pièce a tenir en stock en première urgence

ETK ESPANOL  
01 PIEZA A MANTENER CON PRIORIDAD EN STOCK

Notizen

---

### Bei Ersatzteilbestellungen

erwarten Sie unsere richtige Lieferung; dazu brauchen wir von Ihnen folgende Angaben:

1. **Typenbezeichnung** (z.B. D 100 06)
2. **Variantenbezeichnung** (z.B. NULD)
3. **Traktor- u. Motornummer**
4. **Nummer der Ersatzteil-Nummernliste** (z.B. 580 1213)
5. **Seite**
6. **Bild-Nummer des gewünschten Teiles, wie in der Tafel abgebildet**
7. **Stückzahl des gewünschten Teiles**
8. **Benennung des gewünschten Teiles**

### Bestellbeispiel

Brieflich:

Für Traktor D 100 06 / NULD

Traktor-Nr. 7859/413 Motor-Nr. 8 775 493

Ersatzteil-Nummernliste 580 1213, Seite 11, Bild-Nr. 41

bitte 1 Kolben

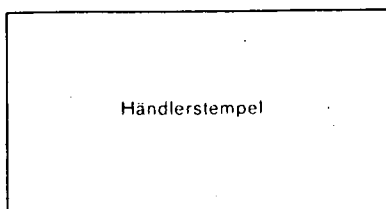

Händlerstempel

**Ihre Ersatzteilbestellung richten Sie bitte an:**

**Ihren zuständigen Vertragshändler.**

### With regard to spare parts orders,

you expect us to ensure correct supply; for this purpose, please quote the following

1. **type designation** (e.g. D 100 06,
2. **variant designation** (e.g. NULD)
3. **tractor No. and engine No.**
4. **No. of spare part numbers list** (e.g. 580 1213)
5. **page**
6. **Fig. No. identifying the part requested, as shown in the illustration**
7. **quantity of the part requested**
8. **denomination of the part requested**

### Example for ordering spare parts

By letter:

For tractor D 100 06 / NULD

tractor No. 7859/413 engine No. 8 775 493

spare part numbers list 580 1213, page 11, Fig. No. 41

1 piston please

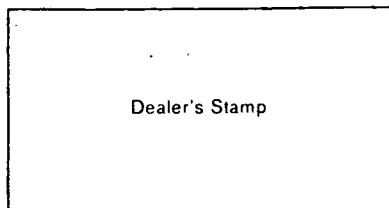

Dealer's Stamp

**Please address your spare parts order to:**

**Our representation competent for you.**

### Pour les commandes de pièces de rechange

vous attendez notre livraison correcte; pour cela nous avons besoin des renseignements suivants:

1. **Désignation du type** (par exemple D 100 06)
2. **Désignation de la variante** (par exemple NULD)
3. **Numéros de tracteur et de moteur**
4. **Numéro du catalogue de pièces de rechange.** (par exemple 580 1213)
5. **Page**
6. **Numéro de figure de la pièce souhaitée, telle que représentée dans la planche**
7. **Quantités de pièces souhaitées**
8. **Désignation de la pièce souhaitées**

### Exemple de commande

Par lettre:

pour tracteur D 100 06 / NULD  
tracteur n° 7859/413 moteur n° 8 775 493  
catalogue de numéros de pièces 580 1213, page 11, fig. 41  
1 piston S.V.P.

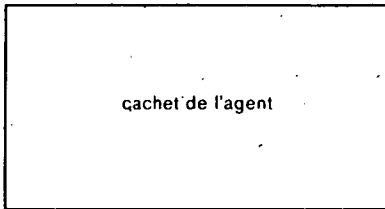

**Veillez adresser votre commande de pièces de rechange à:**

notre représentation compétente pour vous.

### Al pedir repuestos

esperan Uds. un correcto suministro por parte de nosotros, a cuyo objeto necesitamos que Uds. nos indiquen los siguientes datos:

1. **Denominación de tipo** (p. ej D 100 06)
2. **Denominación de la variante** (p. ej. NULD)
3. **Nos. del tractor y del motor**
4. **No. de la lista de Nos. de repuestos** (p. ej. 580 1213)
5. **No. de la página correspondiente**
6. **Fig. No. de la pieza deseada, según representación en el grabado**
7. **Cantidad de la pieza deseada**
8. **Denominación de la pieza deseada**

### Ejemplo para un pedido:

(por escrito)

Para tractor D 100 06 / NULD  
tractor No. 7859/413, motor No. 8 775 493  
lista de Nos. de repuestos 580 1213, página 11, Fig. No. 41  
solicitamos 1 émbolo

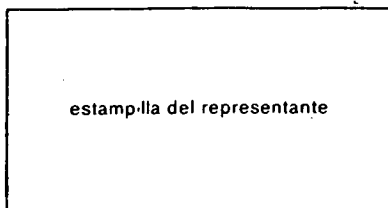

**Rogamos dirijan sus pedidos por repuestos a:**

nuestra representación competente para Vds.

## Kurzzeichen in der Spalte "Stückzahl"

- DS = Dichtungssatz  
Handelt es sich bei der in Spalte 23 angegebenen Nummer um die Teilenummer eines Dichtungssatzes, so wird linksbündig "DS" eingetragen.
- IP = Informationsposition  
Ist ein Teil ungültig, oder wird es als Ersatzteil nicht geliefert, die Teilenummer jedoch zur Information in Spalte 23 angeben, so wird linksbündig "IP" eingetragen.
- MTR = Meterware  
Wird in Spalte 23 nicht die Teilenummer des dargestellten Teiles, sondern die Halbzeugteilenummer der Meterware (z.B. bei Schläuchen) angegeben, so wird "MTR" eingetragen.
- NB = Nach Bedarf  
Kann die erforderliche Stückzahl nicht angegeben werden, z.B. bei Übermaßstufen, so wird linksbündig "NB" eingetragen.
- RS = Reparatursatz  
Handelt es sich bei der in Spalte 23 angegebenen Nummer um die Teilenummer eines Reparatursatzes, so wird linksbündig "RS" eingetragen.
- SP = Sammelpackung  
Handelt es sich bei der in Spalte 23 angegebenen Nummer um die Teilenummer einer Sammelpackung, so wird linksbündig "SP" eingetragen.
- SZ = Satz  
Handelt es sich bei der in Spalte 23 angegebenen Nummer um die Teilenummer eines ganzen Satzes z.B. Ausgleichscheiben, so wird linksbündig "SZ" eingetragen.
- TN = Teilenummern-Listen-Blatt  
Ist unter einer Bild-Nummer eine Komplettierung dargestellt, die auf einem eigenen Teilenummern-Listen-Blatt (Ersatzteil-Nummernlisten-Blatt) aufgegliedert ist, so wird linksbündig "TN" eingetragen.

CODES IN THE COLUMN "STÜCKZAHL"/"QUANTITY"

- DS = Dichtungssatz/Set of gaskets  
If the number quoted in the column "Teile-No." is the part number of a set of gaskets, "DS" will be entered at the left of the column.
- IP = Informationsposition/Information item  
If a part is obsolete or if it is not delivered as spare parts but the part number is quoted in the column "Teile-No." for information, "IP" will be entered at the left of the column.
- MTR = Meterware/Goods by the metre  
If the column "Teile-No." does not include the part number of the illustrated part but the part number of the semi-finished goods by the metre (e.g. in the case of hoses), "MTR" will be entered.
- NB = Nach Bedarf/According to requirement  
If the required quantity cannot be indicated, e.g. in the case of oversizes, "NB" will be entered at the left.
- RS = Reparateursatz/Repair kit  
If the number quoted in the column "Teile-No." is the part number of a repair kit, "RS" will be entered at the left.
- SP = Sammelpackung/Collective package  
If the part number quoted in the column "Teile-No." is the part number of a collective package, "SP" will be entered at the left.
- SZ = Satz/Set  
If the number quoted in the column "Teile-No." is the part number of a complete set, e.g. shims, "SZ" will be entered at the left.
- TN = Teilenummern-Listen-Blatt/Part Numbers List Sheet  
If, under a figure number, a complete sub-assembly is illustrated, which is itemized on a separate part numbers list sheet (spare parts numbers list sheet), "TN" will be entered at the left.

Abréviations dans la colonne " Stückzahl ".

---

- DS = Jeu de joints  
Si le numéro mentionné dans la colonne " Teile Nr." est le no. de fabrication d'un jeu de joints, l'abréviation "DS" est inscrite à gauche.
- IP = Poste d'information  
Si une pièce est annulée, ou n'est pas livrable comme pièce de rechange, le no. de fabrication est indiqué dans la colonne "Teile Nr." à titre d'information. L'abréviation à gauche est alors IP.
- MTR = Articles au mètre  
Si la colonne "Teile Nr." ne mentionne pas le no. de fabrication de la pièce représentée, mais bien le no. de fabrication de l'article semi-fini au mètre (par ex. cas des flexibles) l'abréviation à gauche est MTR.
- NB = Selon besoin  
Si le nombre de pièces nécessaires ne peut être donné par ex. dans le cas de cote réparation, l'abréviation à gauche est NB.
- RS = Ensemble de réparation  
Si le numéro indiqué dans la colonne "Teile Nr." est le no. de fabrication d'un ensemble de réparation, l'abréviation à gauche est RS.
- SP = Lot de pièces  
Si le numéro indiqué dans la colonne "Teile Nr." est le numéro de fabrication d'un lot de pièces, l'abréviation à gauche est SP.
- SZ = Jeu  
Si le numéro indiqué dans la colonne "Teile Nr." est le numéro de fabrication d'un jeu complet, par ex. rondelles d'épaisseur, l'abréviation à gauche est SZ.
- TN = Page de liste de numéros de fabrication  
Si un sous-ensemble est représenté sous un no. de figure dont le détail est donné à part sur une page de la liste des numéros de fabrication (liste des numéros de pièces de rechange) l'abréviation à gauche est TN.

## Abreviaciones en la columna "Cantidad"

---

- DS = Juego de juntas  
Si se trata en el número indicado en la columna "No. de pieza" del número de pieza correspondiente a un juego de juntas, se registra "DS" en la columna "Cantidad", a la izquierda.
- IP = Posición informativa  
Si una pieza no corresponde o no se suministra más como repuesto, indicándose a título informativo su número de pieza en la columna "No. de pieza", se registra "IP" en la columna "Cantidad", a la izquierda.
- MTR = Material por metros lineares  
Si no se indica en la columna "No. de pieza" el número respectivo de la pieza representada, sino el del semiproducto correspondiente al material en metros (p.ej. al tratarse de mangueras), se registra "MTR"
- NB = Según necesidad  
Si no es posible indicar la cantidad necesaria, p.ej. en el caso de medidas de desgaste, se registra "NB" en la columna "Cantidad", a la izquierda.
- RS = Lote para reparaciones  
Si se trata en el número indicado en la columna "No. de pieza" del número de pieza de un lote para reparaciones, se registra "RS" en la columna "Cantidad", a la izquierda.
- SP = Paquete colectivo  
Si se trata en el número indicado en la columna "No. de pieza" del número de pieza para un paquete colectivo, se registra "SP" en la columna "Cantidad", a la izquierda.
- SZ = Juego  
Si se trata en el número indicado en la columna "No. de pieza" del número de pieza correspondiente a un juego completo, p.ej. arandelas de compensación, se registra "SZ" en la columna "Cantidad", a la izquierda.
- TN = Hoja de lista de Nos. de pieza  
Si bajo un No. de fig. queda representada una completación, desglosada por separado en una hoja de lista de Nos. de pieza (hoja de lista de Nos. de repuestos), se registra "TN" en la columna "Cantidad", a la izquierda.

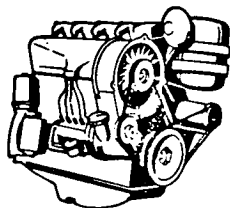

Baugruppen - Verzeichnis  
Index of Construction Groups  
Index des Groupes de Construction  
Indice de los Grupos de Construcción





| Baugruppe: Constr. Group: Groupe/Grupo Constr.:  |  | S./P. |
|--|--|-------|
|  | <b>01</b> Kurbelgehäuse-Oberteil<br>Crankcase<br>Bâti-cylindres<br>Bloque motor  | 26    |
|  | <b>01</b> Zwischenradlagerung<br>Idler gear bearing<br>Tourillon de pignon intermédiaire<br>Soporte para rueda intermedia  | 28    |
|  | <b>01</b> Vorderer Deckel<br>Front cover<br>Couvercle avant<br>Tapa delantera  | 29    |
|  | <b>01</b> Befestigungsteile<br>Fastening parts<br>Pièces de fixation<br>Partes de fijación   | 30    |
|  | <b>01</b> Deckel mit Spannrolle<br>Cover with idler pulley<br>Couvercle avec galet tendeur<br>Tapa con polea tensora   |       |
|  | <b>01</b> Verschluß für Nockenwellenantrieb<br>Camshaft drive cover<br>Pièces obturatrices pour arbre à cames<br>Cierre para accionamiento del árbol de levas                | 31    |
|  | <b>01</b> Verschlußdeckel für Spritzversteller<br>Cover for advance/retard unit<br>Couvercle pour avance automatique<br>Tapa de cierre para graduador de avance de inyección | 32    |
|  | <b>01</b> Deckel<br>Cover<br>Couvercle<br>Tapa   | 33    |
|  | <b>01</b> Spritzdüse<br>Spray nozzle<br>Pulvérisateur<br>Tobera de dispersión  |       |
|  | <b>01</b> Entlüftungsrohr<br>Vent pipe<br>Tuyau de désaération<br>Tubo de purga de aire  | 34    |
|  | <b>01</b> Motorenentlüftung<br>Engine breather<br>Évent du moteur<br>Ventilación del motor   |       |
|  | <b>01</b> Öleinfüllung<br>Oil filler neck<br>Tubulure de remplissage d'huile<br>Tubuladura de llenado  |       |
|  | <b>01</b> Öleinfüllverschluß<br>Oil filler cap<br>Couvercle de cheminée de remplissage d'huile<br>Tapón de llenado de aceite   | 35    |
| <b>01</b> Ölmeßstab<br>Oil dipstick<br>Jauge de niveau d'huile<br>Varilla de sondeo para nivel de aceite | 36   |       |



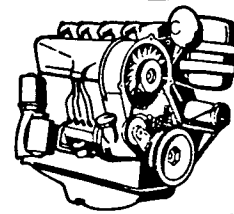

Baugruppen - Verzeichnis  
 Index of Construction Groups  
 Index des Groupes de Construction  
 Indice de los Grupos de Construcción

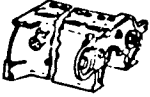

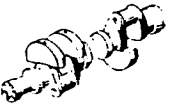

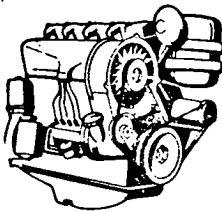



| Baugruppe: Constr. Group: Groupe/Grupo Constr.:                                     |   | S./P. |
|---|---|-------|
|    | <b>01</b> Verschlussbeile<br>Locking parts<br>Pièces de fermeture<br>Partes de cierre   | 37    |
|   | <b>01</b> Ölmeßvorrichtung<br>Oil gauge fitting<br>Dispositif de mesure du niveau d'huile<br>Dispositivo de medición de nivel de aceite |       |
|   |   |       |
|   |   |       |
|    | <b>02</b> Ölwanne<br>Oil pan<br>Carter d'huile<br>Sumidero de aceite  | 38    |
|   | <b>02</b> Verschlussbeile<br>Locking parts<br>Pièces de fermeture<br>Partes de cierre   |       |
|   | <b>02</b> Öltablaß<br>Oil drain<br>Bouchon de vidange d'huile<br>Sistema de vaciado de aceite   |       |
|   | <b>02</b> Öleinfüllung<br>Oil filler neck<br>Tubulure de remplissage d'huile<br>Tubuladura de llenado                                   |       |
|   | <b>02</b> Ölmeßstab<br>Oil dipstick<br>Jauge de niveau d'huile<br>Varilla de sondeo para nivel de aceite                                |       |
|   |   |       |
|  | <b>04</b> Zylinder<br>Cylinder<br>Cylindre<br>Cilindro  | 39    |
|   |   |       |
|  | <b>05</b> Kurbelwelle<br>Crankshaft<br>Vilebrequin<br>Cigüeñal  | 40    |
|   | <b>05</b> Keilriemenscheibe<br>V-belt pulley<br>Poulie de courroie trapézoïdale<br>Polea acanalada                                      | 41    |



Baugruppen - Verzeichnis  
 Index of Construction Groups  
 Index des Groupes de Construction  
 Indice de los Grupos de Construcción

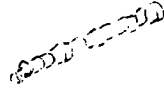



| Baugruppe: Constr. Group: Groupe/Grupo Constr.:                                     |  | S./P. |
|---|--|-------|
|    | <b>05</b> Schwingungsdämpfer<br>Vibration damper<br>Amortisseur de vibrations<br>Amortiguador de vibraciones                       |       |
|   | <b>05</b> Schwungrad<br>Flywheel<br>Volant<br>Volante  | 42    |
|   | <b>05</b> Zahnkranz<br>Ring gear<br>Couronne dentée<br>Corona dentada  |       |
|   |  |       |
|    | <b>06</b> Pleuelstange<br>Connecting rod<br>Bielle<br>Biela  | 43    |
|  | <b>07</b> Kolben<br>Piston<br>Piston<br>Embolo   | 44    |
|  | <b>08</b> Zylinderkopf<br>Cylinder head<br>Culasse<br>Culata   | 46    |
|   | <b>08</b> Zylinderkopfhaube<br>Rocker chamber cover<br>Culasse<br>Caperuza de culata   | 48    |
|   |  |       |
|  | <b>10</b> Nockenwelle<br>Camshaft<br>Arbre à cames<br>Árbol de levas   | 49    |
|   | <b>10</b> Nockenwellen Abtrieb<br>Camshaft drive<br>Prise de mouvement sur arbre à cames<br>Entrega de fuerza en el árbol de levas |       |
|   |  |       |
|  | <b>11</b> Steuerungsteile<br>Timing gears<br>Organes de distribution<br>Partes de distribución                                     | 50    |
|  | <b>14</b> Schmierölpumpe<br>Lube oil pump<br>Pompe d'huile de graissage<br>Bomba de aceite lubricante                              | 51    |

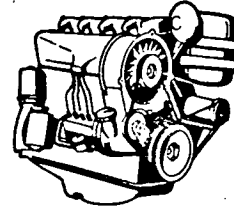

Baugruppen - Verzeichnis  
 Index of Construction Groups  
 Index des Groupes de Construction  
 Indice de los Grupos de Construccion





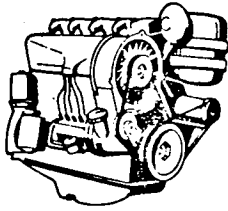

| Baugruppe: Constr. Group: Groupe/Grupo Constr.:                                     |   | S./P. |
|---|---|-------|
|    | <b>14</b><br>Absaugpumpe<br>Drain pump<br>Pompe de renvoi<br>Bomba recuperac  |       |
|    | <b>15</b><br>Schmierölfilter<br>Lube oil filter<br>Filtre à huile-moteur<br>Filtro de aceite lubricante   | 52    |
|   | <b>15</b><br>Nebenstromfeinfilter<br>By-pass microfilter<br>Filtre fin en dérivation<br>Microfiltro en corriente secundaria                                 |       |
|   | <b>15</b><br>Filterpatrone<br>Filter cartridge<br>Cartouche de filtre<br>Cartucho de filtro   |       |
|   | <b>15</b><br>Spaltfilteranbau<br>Edge-type filter mounting<br>Pièces de fixation pour filtre à nettoyage mécanique<br>Sistema de montaje de filtro mecánico |       |
|   | <b>15</b><br>Flansch mit Befestigung<br>Flange with fastenings<br>Flasque et fixation<br>Brida con elementos de fijación                                    |       |
|   | <b>15</b><br>Ventil<br>Valve<br>Vanne<br>Válvula  |       |
|   | <b>15</b><br>Schmierölkühler<br>Lube oil cooler<br>Radiateur d'huile de graissage<br>Refrigerador de aceite lubricante                                      |       |
|   | <b>15</b><br>Wandlerölkühler<br>Torque converter oil cooler<br>Refroidisseur d'huile de convertisseur<br>Refrigerador de aceite de convertidor              |       |
|   | <b>15</b><br>Hohlschraube<br>Banjo bolt<br>Vis banjo<br>Tornillo racor  |       |
|   |   |       |
|  | <b>16</b><br>Öldruckrohr<br>Oil delivery pipe<br>Tube de refoulement d'huile<br>Tubo de presión de aceite   | 53    |
|   | <b>16</b><br>Schmierölansaugleitung<br>Lube oil suction pipe<br>Tuyau d'aspiration d'huile<br>Tuberia de aspiración de aceite lubricante                    | 54    |
|   | <b>16</b><br>Schmierölleitung<br>Lube oil pipe<br>Conduite d'huile de graissage<br>Tuberia de aceite lubricante   |       |

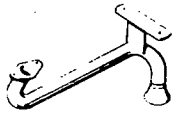

Baugruppen - Verzeichnis  
 Index of Construction Groups  
 Index des Groupes de Construction  
 Indice de los Grupos de Construcción



| Baugruppe: Constr. Group: Groupe/Grupo Constr.:                                     |   | S./P. |
|---|---|-------|
|    | <b>16</b> Kurzschlußleitung<br>By-pass line<br>Conduite de by-pass<br>Tubería by-pass   | 55    |
|   |   |       |
|    | <b>17</b> Einspritzpumpe<br>Injection pump<br>Pompe d'injection<br>Bomba de inyección   | 56    |
|   | <b>17</b> Verteilereinspritzpumpe<br>Distributor injection pump<br>Pompe distributrice d'injection<br>Bomba de inyección, de pistón de distribución |       |
|   | <b>17</b> Überströmventil<br>Overflow valve<br>Valve de décharge<br>Válvula de rebosamiento   | 57    |
|   | <b>17</b> Drehzahlverstellung<br>Speed control<br>Changement de vitesse<br>Graduación de revoluciones   |       |
|   | <b>17</b> Rohrleitung<br>Piping<br>Tuyauteries<br>Tuberías  |       |
|  | <b>18</b> Spritzversteller<br>Advance / retard unit<br>Avance automatique<br>Graduador de avance de inyección                                       |       |
|   | <b>18</b> Einspritzpumpenantrieb<br>Injection pump drive<br>Entraînement de pompe d'injection<br>Accionamiento para bomba de inyección              | 58    |
|   |   |       |
|  | <b>19</b> Einspritzventil<br>Injector<br>Injecteur<br>Inyector  | 59    |
|   |   |       |
|  | <b>20</b> Kraftstofffilter<br>Fuel filter<br>Filtre nourrice<br>Filtro de combustible   | 60    |
|   | <b>20</b> Konsole mit Befestigung<br>Bracket with fastenings<br>Console avec fixation<br>Consola con elementos de fijación                          |       |



Baugruppen - Verzeichnis  
 Index of Construction Groups  
 Index des Groupes de Construction  
 Indice de los Grupos de Construccion

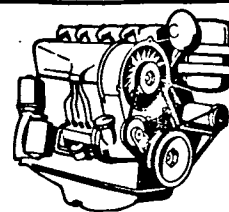

Baugruppe: Constr. Group: Groupe/Grupo Constr.:



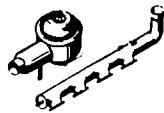

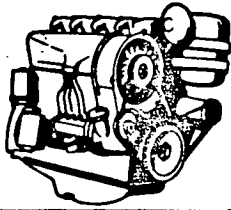
S./P.

|   |   |    |
|---|---|----|
|   |   |    |
|    | <b>21</b> Einspritzleitungen<br>Injection pipes<br>Tuyauteries de injection<br>Tuberias de inyección  | 61 |
|   | <b>21</b> Überströmventil<br>Overflow valve<br>Valve de décharge<br>Válvula de rebosamiento   |    |
|   | <b>21</b> Kraftstoffleitungen<br>Fuel pipes<br>Tuyauteries à combustible<br>Tuberias de combustible   | 62 |
|   | <b>21</b> Kraftstoffleitungen<br>Fuel pipes<br>Tuyauteries à combustible<br>Tuberias de combustible   |    |
|   | <b>21</b> Überströmleitung<br>Overflow pipe<br>Conduit de décharge<br>Tuberia de rebosamiento   | 63 |
|   | <b>21</b> Leckölleitungen<br>Leak oil pipes<br>Tuyauteries des fuites<br>Tuberias de combustible sobrante   | 64 |
|   | <b>21</b> Kraftstoffbehälter mit Befestigung<br>Fuel tank with fastenings<br>Réservoir à gas-oil avec attaches<br>Tanque de combustible con elementos de fijación                 |    |
|   | <b>21</b> Tragschiene mit Befestigung<br>Carrier rail with fastenings<br>Barrette-support avec fixation<br>Carril de soporte con elementos de fijación                            |    |
|  | <b>22</b> Luftansaugrohr<br>Air intake manifold<br>Tuyau d'admission d'air<br>Tubo de aspiración de aire  | 65 |
|   | <b>22</b> Anschlußkrümmer<br>Connecting elbow<br>Coude raccord<br>Codo de empalme   |    |
|   | <b>22</b> Ölbadluftfilter<br>Oil bath air cleaner<br>Épurateur d'air à bain d'huile<br>Filtro de aire en baño de aceite   |    |
|   | <b>22</b> Ölbadluftfilterbefestigung<br>Oil-bath air cleaner fixation<br>Fixation d'épurateur d'air à bain d'huile<br>Elementos de fijación para filtro de aire en baño de aceite |    |



Baugruppen - Verzeichnis  
Index of Construction Groups  
Index des Groupes de Construction  
Indice de los Grupos de Construccion



| Baugruppe: Constr. Group: Groupe/Grupo Constr.:                                     |   | S./P. |
|---|---|-------|
|    | <b>33</b> Verschußteile<br>Locking parts<br>Pièces de fermeture<br>Partes de cierre   | 66    |
|   | <b>33</b> Anbauteile für Luftpresse<br>Mounting parts for air compressor<br>Pièces de fixation de compresseur d'air<br>Partes de montaje para compresor de aire |       |
|   |   |       |
|    | <b>35</b> Armaturenkasten<br>Instrument panel<br>Tableau de bord<br>Caja de instrumentos  |       |
|   | <b>35</b> Konsole<br>Bracket<br>Console<br>Consola  |       |
|   |   |       |
|  | <b>39</b> Kühlgebläse<br>Cooling air blower<br>Turbine de refroidissement<br>Ventilador de refrigeración  | 67    |
|   | <b>39</b> Keilriemen<br>V-belt<br>Courroie trapézoidale<br>Correa trapezoidal   |       |
|   |   |       |
|  | <b>40</b> Luftführungsleiste<br>Baffle mounting plate<br>Plinthe de hotte de guidage d'air<br>Listón guía de aire   | 68    |
|   | <b>40</b> Luftführungshaube<br>Air cowling<br>Manche d'air<br>Manga guía de aire  |       |
|   | <b>40</b> Verschußblech<br>Closing sheet<br>Tôle d'obturation<br>Chapa de cierre  |       |
|   | <b>40</b> Standblech (hinten)<br>Stay plate, rear<br>Tôle verticale (AR)<br>Chapa vertical (atrás)  | 69    |
|   | <b>40</b> Luftführungsunterteil<br>Air cowling base<br>Partie inférieure hotte guidage d'air<br>Parte inferior de guía de aire                                  | 70    |



Baugruppen - Verzeichnis  
 Index of Construction Groups  
 Index des Groupes de Construction  
 Índice de los Grupos de Construcción

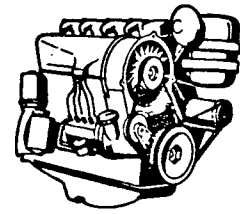

Baugruppe: Constr. Group: Groupe/Grupo Constr.:

S./P.

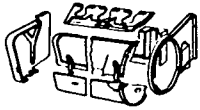

**40** Luftführungsblech  
 Air guide plate  
 Tôle déflectrice d'air  
 Chapa guía de aire 71

**40** Luftführungsblech  
 Air guide plate  
 Tôle déflectrice d'air  
 Chapa guía de aire

**40** Abluftkasten  
 Air discharge frame  
 Hotte de départ d'air vicié  
 Caja de evacuación de aire

**40** Seitendeckel  
 Side cover  
 Couvercle latéral  
 Tapa lateral

**40** Verschlussdeckel  
 Cover  
 Couvercle  
 Tapa

**40** Abschirmblech  
 Air shield  
 Tôle déflectrice  
 Chapa deflectora 72

**40** Standblech (vorne)  
 Stay plate, front  
 Tôle verticale (AV)  
 Chapa vertical (delante) 73

**40** Heizkasten  
 Heater box  
 Boite de chauffage  
 Caja de calefacción

**40** Luftzuführungsring  
 Air guide ring  
 Bague d'arrivée d'air  
 Aro de entrada de aire

**40** Abdichtbürste  
 Sealing brush  
 Brosse de colerette  
 Cepillo de hermetización

**40** Kühlluftführung für Generator  
 Cooling air duct for generator  
 Gaine d'air de refroidissement pour l'alternateur  
 Conducción de aire para generatriz

**40** Abluftteile  
 Exhaust-air cowling parts  
 Tôlerie de sortie d'air  
 Partes para sistema de desviación de aire



**41** Auspuffsammelrohr  
 Exh. manifold  
 Collecteur d'échappement  
 Colector de escape 74

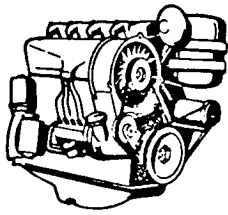

Baugruppen - Verzeichnis  
 Index of Construction Groups  
 Index des Groupes de Construction  
 Indice de los Grupos de Construcción



| Baugruppe: Constr. Group: Groupe/Grupo Constr.: |   | S./P. |
|---|---|-------|
|   | <b>41</b> Auspuffschalldämpfer<br>Exhaust silencer<br>Silencieux d'échappement<br>Silencioso de escape                        |       |
|   | <b>41</b> Auspuffsammeldämpfer<br>Exh. silencing manifold<br>Collecteur silencieux d'échappement<br>Silenciador de escape     |       |
|   | <b>41</b> Gegenflansch<br>Counterflange<br>Contre-bride<br>Contrabrida  | 75    |
|   | <b>41</b> Befestigungsteile<br>Fastening parts<br>Pièces de fixation<br>Partes de fijación                                    |       |
|   | <b>41</b> Auspuffrohrverbindung<br>Exhaust manifold connection<br>Raccord de tuyau d'échappement<br>Unión para tubo de escape |       |
|   | <b>41</b> Reduzierstück<br>Reducer<br>Pièce de réduction<br>Reductor  |       |
|   |   |       |
|   | <b>44</b> Lichtmaschine<br>Dynamo<br>Dynamo<br>Generatriz   | 76    |
|   | <b>44</b> Antriebsteile<br>Driving parts<br>Pièces d'entraînement<br>Piezas de accionamiento                                  | 77    |
|   | <b>44</b> Befestigungsteile<br>Fastening parts<br>Pièces de fixation<br>Partes de fijación                                    | 78    |
|   | <b>44</b> Keilriemenscheibe<br>V-belt pulley<br>Poulie de courroie trapézoïdale<br>Polea acanalada                            |       |
|   | <b>44</b> Keilriemen<br>V-belt<br>Courroie trapézoïdale<br>Correa trapezoidal   | 79    |
|   | <b>44</b> Abschirmblech<br>Air shield<br>Tôle défectrice<br>Chapa deflectora  | 80    |
|   | <b>44</b> Reglerschalter<br>Regulator cutout<br>Disjoncteur-régulateur<br>Disyuntor   | 81    |





Baugruppen - Verzeichnis  
 Index of Construction Groups  
 Index des Groupes de Construction  
 Indice de los Grupos de Construcción

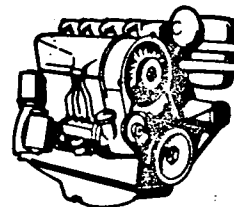

Baugruppe: Constr. Group: Groupe/Grupo Constr.:

S./P.



**44** Steckverbindung  
 Plug & socket connection  
 Prise et fiche  
 Unión de enchufe

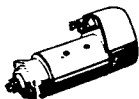

**44** Elektr. Anlasser  
 Electr. starter motor  
 Démarreur électr.  
 Arrancador eléctrico

82

**44** Schutzkappe  
 Protective cape  
 Chapeau de protection  
 Sombrerete de protección



**46** Motoraufhängung  
 Engine suspension.  
 Suspension du moteur  
 Suspensión del motor



**48** Elektrische Leitungen  
 Wiring  
 Câbles  
 Cables

83

**48** Öl druckschalter  
 Oil press. switch  
 Commutateur à pression d'huile  
 Conmutador para presión de aceite

**48** Öl druckgeber  
 Oil pressure switch  
 Mano-contact d'huile  
 Transmisor de presión de aceite

**48** Elektrisches Grundzubehör  
 Basic electr. accessories  
 Accessoires électr. de base  
 Accesorios eléctricos básicos

**48** Glühlampen  
 Bulbs  
 Lampes à incandescence  
 Bombillas

**48** Anschlußteile  
 Connecting parts  
 Pièces d'adaptation  
 Piezas de conexión

**48** Kabellochband  
 Punched tape  
 Ruban de câble à boutonnières  
 Cinta perforada atacable

84

**48** Batterie-Umschalter  
 Battery changeover switch  
 Commutateur de batterie  
 Conmutador de batería





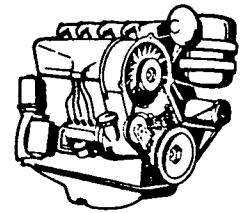



Baugruppen - Verzeichnis  
 Index of Construction Groups  
 Index des Groupes de Construction  
 Índice de los Grupos de Construcción



| Baugruppe: Constr. Group: Groupe/Grupo Constr.: |   | S./P. |
|---|---|-------|
|   | <b>51</b> Temperaturkontaktgeber<br>Temp. contact maker<br>Transmetteur de contact de température<br>Transmisor de contacto de temperatura                            | 85    |
|   | <b>51</b> Temperaturmessung<br>Temp. measurement<br>Mesure de la température<br>Medición de temperatura   | 86    |
|   | <b>51</b> Betriebsstundenzähler<br>Service hourmeter<br>Horamètre<br>Totalizador de horas de servicio   |       |
|   | <b>51</b> Öldruckschalter<br>Oil press. switch<br>Commutateur à pression d'huile<br>Conmutador para presión de aceite   |       |
|   |   |       |
|   | <b>52</b> Anschlußgehäuse<br>Adapter housing<br>Carter d'adaptation<br>Caja de conexión   |       |
|   | <b>52</b> Anbauteile<br>Attachments<br>Accessoires<br>Partes de adosamiento   |       |
|   | <b>52</b> Befestigungsteile<br>Fastening parts<br>Pièces de fixation<br>Partes de fijación  |       |
|   | <b>52</b> Anflanschaußenlager<br>Power take-off flange type<br>Palier extérieur à bride<br>Soporte exterior de brida  |       |
|   | <b>52</b> Flanschkupplung<br>Flange coupling<br>Accouplement à bride<br>Acoplamiento a brida  |       |
|   | <b>52</b> Scheibenkupplung<br>Disc clutch<br>Embrayage à disque<br>Embrague de lâminas  |       |
|   | <b>52</b> Twin-Disc-Kupplung<br>Twin-Disc clutch<br>Embrayage Twin-Disc<br>Embrague Twin-Disc   |       |
|   | <b>52</b> Planox Kupplung<br>Planox clutch<br>Embrayage Planox<br>Embrague Planox   |       |
|   | <b>83</b> Verschlußteile zur Hydraulikpumpe<br>Locking parts for hydraulic pump<br>Pièces d'obturation de pompe hydraulique<br>Partes de cierre para bomba hidráulica | 87    |

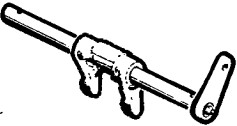
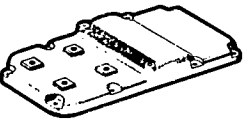
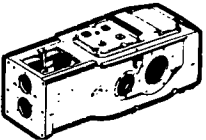
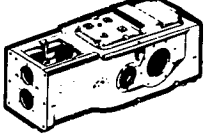
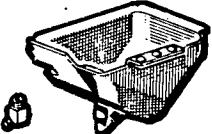

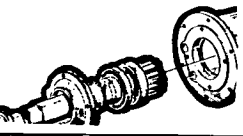
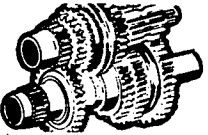



Baugruppen - Verzeichnis  
 Index of Construction Groups  
 Index des Groupes de Construction  
 Indice de los Grupos de Construcción

| Baugruppe: Constr. Group: Groupe/Grupo Constr.:                                     |   | S./P. |
|---|---|-------|
|    | 02 Wechselkupplung mit Ausrücker<br>Selective Clutch with Disengager<br>Coupleur inverseur avec débrayeur<br>Embrague inversor con desinbragador  | 88    |
|    | 02 Wechselkupplung<br>Selective Clutch<br>Coupleur inverseur<br>Embrague inversor   | 89    |
|    | 03 Kupplungsbetätigung<br>Clutch Control Assembly<br>Actionnement d'embrayage<br>Accionamiento del embrague   | 91    |
|    | 08 Gehäusedeckel<br>Housing Cover<br>Couver de Carter<br>Tapa del Carter  | 92    |
|   | TW 50.3<br>08 <b>Getriebegehäuse</b><br><b>Transmission Case</b><br><b>Carter de transmission</b><br><b>Caja del tren de engranajes</b>   | 93    |
|  | TW 50.3<br>08 <b>Getriebegehäuse (Allrad)</b><br><b>Transmission Case - Four Wheel Drive</b><br><b>Carter de transmission - toutes roues motrices</b><br><b>Caja de la transmisión - tracción en las 4 ruedas</b> | 94    |
|  | 09 Kupplungsgehäuse - Befestigungsteile<br>Clutch Housing - Securing Parts<br>Cloche d'embrayage - Attaches<br>Caja del ambrague - Partes del fijación  | 95    |
|  | 09 <b>Kupplungsgehäuse</b><br><b>Clutch Housing</b><br><b>Cloche d'embrayage</b><br><b>Caja del ambrague</b>  | 96    |
|  | 09 Zwischengetriebe<br>Intermediate - Gear Box<br>Boîte à Vitesses - intermédiaire<br>Caja de cambios de velocid. - intermedia  | 97    |
|  | 11 <b>Wechselgetriebe</b><br><b>Change-speed Gearbox</b><br><b>Boîte de vitesses</b><br><b>Cambio de marchas</b>  | 98    |
|  | 12 <b>Schaltung zum Wechselgetriebe</b><br><b>Gear-shift Assembly</b><br><b>Organes d'actionnement de la boîte de vitesses</b><br><b>Mando para caja de velocidades</b>   | 102   |

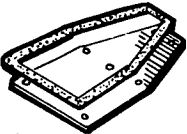
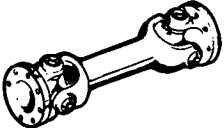
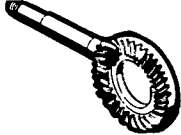

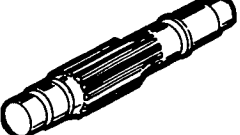

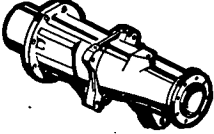
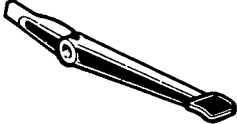
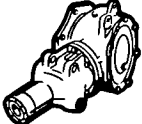
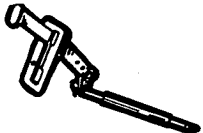

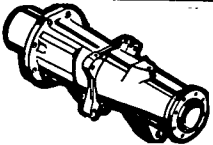
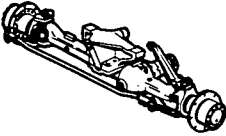
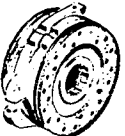
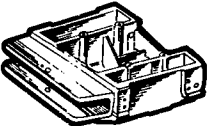
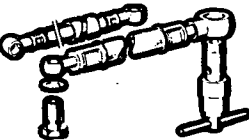

Baugruppen - Verzeichnis  
 Index of Construction Groups  
 Index des Groupes de Construction  
 Indice de los Grupos de Construcción

| Baugruppe: Constr. Group: Groupe/Grupo Constr.:                                     |   | S./P. |
|---|---|-------|
|    | 14<br>Verschlußdeckel - (Zapfw.-Schaltung)<br>Closing Cover - (PTO Control Assembly)<br>Couvercle de ferm - (Comm. d. prise d. force)<br>Cierre de tapa - (Mando para árbol toma de fuerza) | 104   |
|    | 17<br>Verschlußdeckel - (Mähbalkenantrieb)<br>Closing Cover - (Mower Drive)<br>Couvercle de ferm - (Mécanisme d. comm. barre d. coupe)<br>Cierre de tapa - (Accionamiento d. segadora)      | 105   |
|    | 21<br>Gelenkwelle<br>Joint Shaft<br>Arbre à cardans<br>Arbol cárden   | 106   |
|    | 23<br>Kegetrieb<br>Bevel Drive<br>Couple conique<br>Grupo cónico  | 107   |
|   | 23<br>Zwischenwelle<br>Intermediate Shaft<br>Arbre Intermédiaire<br>Eje Intermedio  | 108   |
|  | 23<br>Zwischenwelle - kurz<br>Intermediate Shaft - short<br>Arbre Intermédiaire - court<br>Eje intermedio - corto   | 109   |
|  | 24<br>Ausgleichgetriebe<br>Differential Unit<br>Différentiel<br>Diferencial   | 110   |
|  | 25<br>Verschlußteile (Hinterachse)<br>Blanking Parts for Rear Axle<br>Obturations (Pont Arrière)<br>Piezas de cierre (eje trasero)  | 112   |
|  | 25<br>Ausgleichgetriebeesperre<br>Differential Lock<br>Blocage du différentiel<br>Bloqueo del diferencial   | 113   |
|  | 26<br>Vorderradantrieb<br>Front Wheel Drive<br>Commande des roues AV<br>Propulsión delantera  | 114   |
|  | 26<br>Schaltung für Vorderradantrieb<br>Front Wheel Drive Control Assembly<br>Commande du pont-moteur AV<br>Conexión para tracción delantera  | 117   |

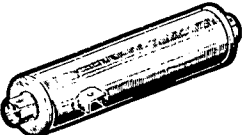
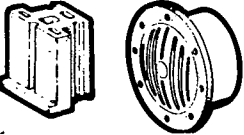

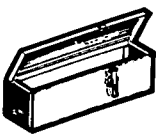
Baugruppen - Verzeichnis  
 Index of Construction Groups  
 Index des Groupes de Construction  
 Indice de los Grupos de Construcción

| Baugruppe: Constr. Group: Groupe/Grupo Constr.:                                     |  | S./P. |
|---|--|-------|
|    | 27<br><b>Hinterachse - Scheibenbremse</b><br><b>Standard Rear Axle-Disc Brake</b><br><b>Train AR-Frein à disque</b><br><b>Puente trasero-Freno de disco</b>                            | 118   |
|    | 28<br><b>Angetriebene Vorderachse</b><br><b>Driven Front Axle</b><br><b>Essieu AV moteur</b><br><b>Eje delantero con accionamiento</b>   | 120   |
|    | 30<br><b>Scheibenbremse</b><br><b>Disc Brakes</b><br><b>Frein à disque</b><br><b>Freno de disco</b>  | 125   |
|    | 32<br><b>Vorderachslagerbock</b><br><b>Front Axle Bracket</b><br><b>Berceau de l'essieu AV</b><br><b>Caballote de soporte del eje delantero</b>  | 127   |
|   | 42<br><b>Teile zum Kraftstoffbehälter</b><br><b>Accessories for Fuel Tank</b><br><b>Pièces diverses appartenant au réservoir à gas-oil</b><br><b>Partes para tanque de combustible</b> | 128   |
|  | 43<br><b>Trockenluftfilter</b><br><b>Dry-type Air Cleaner</b><br><b>Epurateur d'air du type sec</b><br><b>Filtro de aire en seco</b>   | 129   |
|  | 44<br><b>Auspufftopf</b><br><b>Exhaust Silencer</b><br><b>Pot d' Echappement</b><br><b>Silencioso Estape</b>   | 130   |
|  | 49<br><b>Teile zur Eektr.-Ausrüstung</b><br><b>Accessories for Electrical Equipment</b><br><b>Pièces diverses de l'équipement électrique</b><br><b>Partes para equipo eléctrico</b>    | 131   |
|  | 57<br><b>Verschlußstopfen</b><br><b>Screw Plug</b><br><b>Bouchon d'obturation</b><br><b>Tapón roscado</b>  | 132   |
|  | 60<br><b>Werkzeugkasten</b><br><b>Toolbox</b><br><b>Coffret à outils</b><br><b>Caja de herramientas</b>  | 133   |
|  | 77<br><b>Verschlußdeckel - (Zapfwelle)</b><br><b>Closing Cover - (PTO Shaft)</b><br><b>Couvercle de ferm - (Prise de force,</b><br><b>Cierre de tapa - (Arbol toma de fuerza)</b>      | 134   |



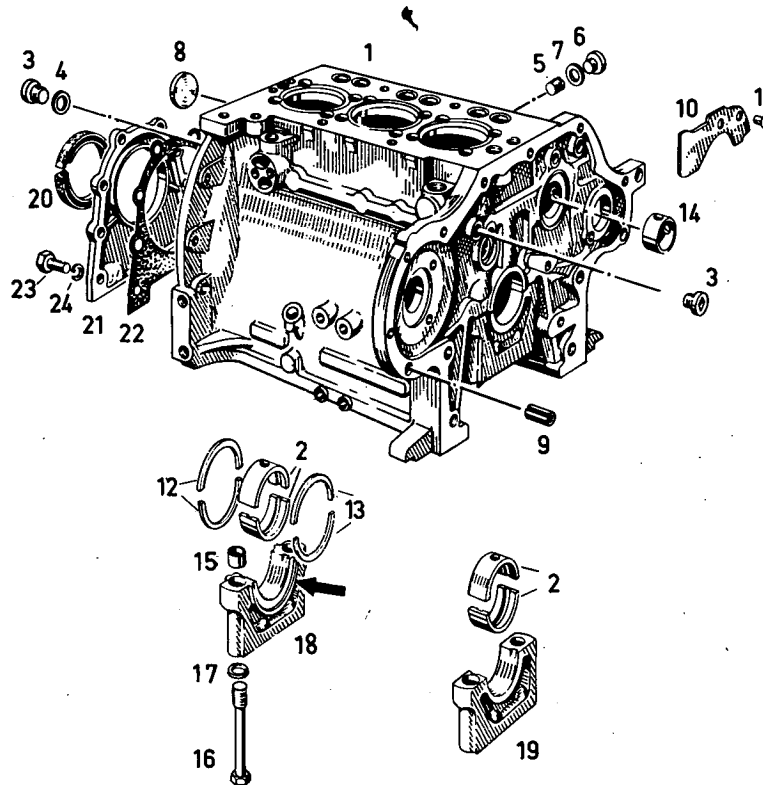
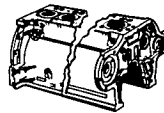

0150-01 500 6748

| Bild Nr. | Teile-Nr. | Stück-Zahl | Deutsch             | English         | Français           | Español            | Numer / Bemerkung   | ETK |
|----------|-----------|------------|---------------------|-----------------|--------------------|--------------------|---|-----|
| 1        | 223 0526  | 1          | KURBELGEH. OBERTEIL | CRANKCASE       | CARTER SUPERIEUR   | BLOQUE MOTOR       | BEST.AUS POS.3-11.14  |     |
| 2        | 336 2379  | 4          | KURBELWELLENLAGER   | MAIN BEARING    | PALIER LIGNE ARBRE | COJ.BANCADA        | 0150-01-27.59/61<br>NORMAL 70.00 MM RD(2.7559 IN)<br>UNTERMASSTUFEN 950-955 | 01  |
| 3        | 121 4988  | 2          | VERSCHLUSSSCHRAUBE  | SCREW PLUG      | BOUCHON FILETE     | TAPON ROSCADO      | 2 827 A 3   |     |
| 4        | 111 8707  | 2          | DICHRING            | WASHER          | BAGUE D'ETANCHEITE | ANILLO DE JUNTA    | A 16 X 22 DIN 7603-CU   |     |
| 5        | 121 5235  | 4          | SCHLITZSTOPFEN      | SLOTTED PLUG    | BOUCHON FENDU      | TAPON RANURADO     | 860 B   |     |
| 6        | 112 2350  | 3          | VERSCHLUSSSCHRAUBE  | SCREW PLUG      | BOUCHON FILETE     | TAPON ROSCADO      | M12X1,5 DIN 908 PHOSPH  |     |
| 7        | 111 8673  | 3          | DICHRING            | WASHER          | BAGUE D'ETANCHEITE | ANILLO DE JUNTA    | A 12 X 15,5 DIN 7603-CU   |     |
| 8        | 121 6240  | 1          | VERSCHLUSSSCHEIBE   | DISHED PLUG     | RONDELLE OBTURAT.  | ARANDELA CIERRE    | 2 872 A 1   |     |
| 9        | 116 7266  | 2          | SPANNBUCHSE         | CLAMPING BUSH   | DOUILLE DE SERRAGE | CASQUILLO FIADOR   | 811X16H 2341  |     |
| 10       | 223 1082  | 1          | PRALLBLECH          | DEFLECTOR PLATE | CHICANE            | CHAPA DE CHOQUE    |   |     |
| 11       | 111 5333  | 2          | HALBRUNDKERBNAGEL   | NOTCHED NAIL    | ERGOT A ENCOCHE    | CLAVIJA RANURADA   | 6 X10 DIN 1476 VZKC   |     |
| 12       | 223 0181  | 1          | ANLAUFRING          | STOP RING       | BAGUE BUTEE        | ANILLO TOPE        | NORMAL 3,00 MM (0.1181 IN)<br>UEBERMASSTUFEN 956-959                        | 01  |
| 13       | 223 0170  | 1          | ANLAUFRING          | STOP RING       | BAGUE BUTEE        | ANILLO TOPE        | NORMAL 3,00 MM (0.1181 IN)<br>UEBERMASSTUFEN 960-963                        | 01  |
| 14       | 213 9737  | 1          | BUCHSE              | BUSH            | DOUILLE            | CASQUILLO          |   |     |
| 15       | 336 2279  | 8          | PASSBUCHSE          | DOWEL BUSH      | DOUILLE CENTRAGE   | CASQ.AJUSTE        | 0150-01-01.87   |     |
| 16       | 116 9634  | 8          | SKT.DEHNSCHRAUBE    | WAISTED BOLT    | VIS EXTENS 6 PANS  | TORN.HEX.EXPANSION | M14 X110 H 803-10.9   | 01  |
| 17       | 121 6107  | 8          | SCHEIBE             | DISC/PANE/PLATE | RONDELLE/DISQUE    | DISCO/CRISTAL/PLAT | 2 308 A 11  |     |
| 18       | 213 8184  | 1          | LAGERDECKEL         | BEARING CAP     | CHAPEAU DE PALIER  | TAPA SOPORTE       | PASSLAGER   |     |
| 19       | 213 8185  | 3          | LAGERDECKEL         | BEARING CAP     | CHAPEAU DE PALIER  | TAPA SOPORTE       | NORMAL  |     |
| 20       | 116 0097  | 1          | WELLENDICHRING      | SHAFT SEAL      | JOINT D'ARBRE      | ANILLO HERMET.EJE  | L 115X140 X16 H 2940-SI   | 01  |
| 21       | 213 7842  | 1          | DECKEL              | COVER           | COUVERCLE          | TAPA               |   |     |

| Bld<br>Nr. | Teil-Nr. | Stück-<br>Zahl | Deutsch           | English           | Français           | Español            | Nummer/Bemerkung  | ETK |
|------------|----------|----------------|-------------------|-------------------|--------------------|--------------------|---|-----|
| 22         | 336 2337 | 1              | DICHTUNG          | GASKET            | GARNITURE/JOINT    | JUNTA              | 0150-01-20.03   |     |
| 23         | 111 2322 | 8              | SECHSKANTSCHRAUBE | HEX.BOLT          | VIS 6 PANS         | TORNILLO HEXAGONAL | M 8 X 20 DIN 933- 8.8-A4C                                   |     |
| 24         | 110 2799 | 8              | FEDERING          | SPRING LOCKWASHER | RONDELLE GROWER    | ARANDELA ELASTICA  | A 8 DIN 128 A4C   |     |
| 950        | 336 2380 | 4              | KURBELWELLENLAGER | MAIN BEARING      | PALIER LIGNE ARBRE | COJ.BANCADA        | 0150-01-27.62/63<br>1.UNTERMASST.69,75 MM RD<br>(2.7459 IN) |     |
| 951        | 336 2381 | 4              | KURBELWELLENLAGER | MAIN BEARING      | PALIER LIGNE ARBRE | COJ.BANCADA        | 0150-01-27.64/65<br>2.UNTERMASST.69,50 MM RD<br>(2.7362 IN) |     |
| 952        | 336 2382 | 4              | KURBELWELLENLAGER | MAIN BEARING      | PALIER LIGNE ARBRE | COJ.BANCADA        | 0150-01-27.66/67<br>3.UNTERMASST.69,25 MM RD<br>(2.7263 IN) |     |
| 953        | 336 2383 | 4              | KURBELWELLENLAGER | MAIN BEARING      | PALIER LIGNE ARBRE | COJ.BANCADA        | 0150-01-27.68/69<br>4.UNTERMASST.69,00 MM RD<br>(2.7165 IN) |     |
| 954        | 336 2384 | 4              | KURBELWELLENLAGER | MAIN BEARING      | PALIER LIGNE ARBRE | COJ.BANCADA        | 0150-01-27.71/72<br>5.UNTERMASST.68,75 MM RD<br>(2.7066 IN) |     |
| 955        | 336 2385 | 4              | KURBELWELLENLAGER | MAIN BEARING      | PALIER LIGNE ARBRE | COJ.BANCADA        | 0150-01-27.73/74<br>6.UNTERMASST.68,50 MM RD<br>(2.6968 IN) |     |
| 956        | 223 0182 | 1              | ANLAUFRING        | STOP RING         | BAGUE BUTEE        | ANILLO TOPE        | 1.UEBERMASST.3,25 MM<br>(0.1279 IN)                         |     |
| 957        | 223 0183 | 1              | ANLAUFRING        | STOP RING         | BAGUE BUTEE        | ANILLO TOPE        | 2.UEBERMASST.3,50 MM<br>(0.1378 IN)                         |     |
| 958        | 223 0184 | 1              | ANLAUFRING        | STOP RING         | BAGUE BUTEE        | ANILLO TOPE        | 3.UEBERMASST.3,75 MM<br>(0.1476 IN)                         |     |
| 959        | 223 0185 | 1              | ANLAUFRING        | STOP RING         | BAGUE BUTEE        | ANILLO TOPE        | 4.UEBERMASST.4,00 MM<br>(0.1575 IN)                         |     |
| 960        | 223 0172 | 1              | ANLAUFRING        | STOP RING         | BAGUE BUTEE        | ANILLO TOPE        | 1.UEBERMASST.3,25 MM<br>(0.1279 IN)                         |     |
| 961        | 223 0173 | 1              | ANLAUFRING        | STOP RING         | BAGUE BUTEE        | ANILLO TOPE        |   |     |
| 962        | 223 0174 | 1              | ANLAUFRING        | STOP RING         | BAGUE BUTEE        | ANILLO TOPE        | 3.UEBERMASST.3,75 MM<br>(0.1476 IN)                         |     |
| 963        | 223 0175 | 1              | ANLAUFRING        | STOP RING         | BAGUE BUTEE        | ANILLO TOPE        | 4.UEBERMASST.4,00 MM<br>(0.1575 IN)                         |     |



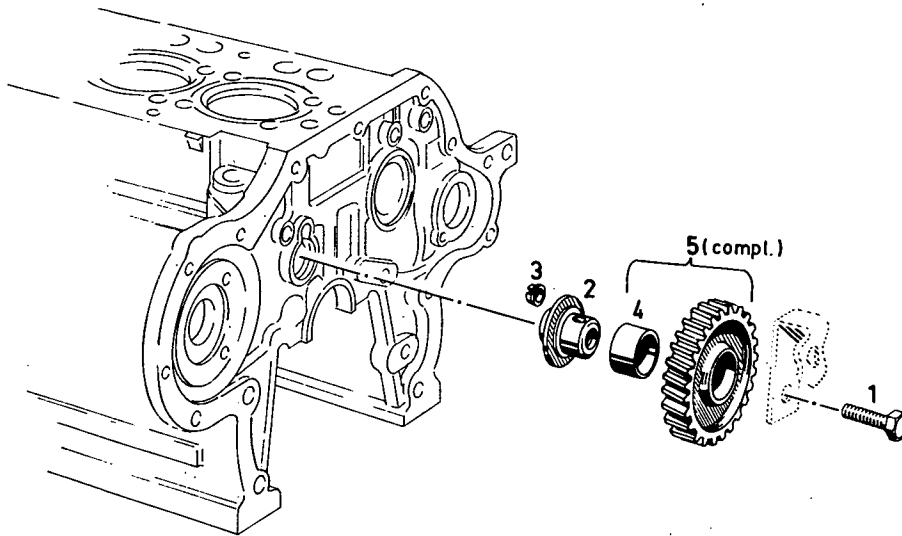
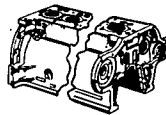

0150-01 500 3301

| Bild Nr. | Teile-Nr. | Stück-Zahl | Deutsch           | English       | Français           | Español            | Nummer/Bemerkung         | ETK |
|----------|-----------|------------|-------------------|---------------|--------------------|--------------------|--------------------------|-----|
| 1        | 110 3076  | 1          | SECHSKANTSCHRAUBE | HEX.BOLT      | VIS 6 PANS         | TORNILLO HEXAGONAL | M10x 60 DIN 933-10.9-A4C |     |
| 2        | 210 1006  | 1          | LAGERZAPFEN       | JOURNAL       | TOURILLON/MANETON  | MUNON SOPORTE      | 0150-01-45.08            |     |
| 3        | 210 1007  | 1          | SPANNBUCHSE       | CLAMPING BUSH | DOUILLE DE SERRAGE | CASQUILLO FIADOR   | 0150-01-45.09            |     |
| 4        | 336 2538  | 1          | BUECHSE           | BUSH          | BOITE              | CASQUILLO          | 0150-01-74.02            |     |
| 5        | 336 2541  | 1          | ZAHNRAD           | GEAR          | ROUE DENTEE        | RUEDA DENTADA      | 0150-01-74.20            |     |

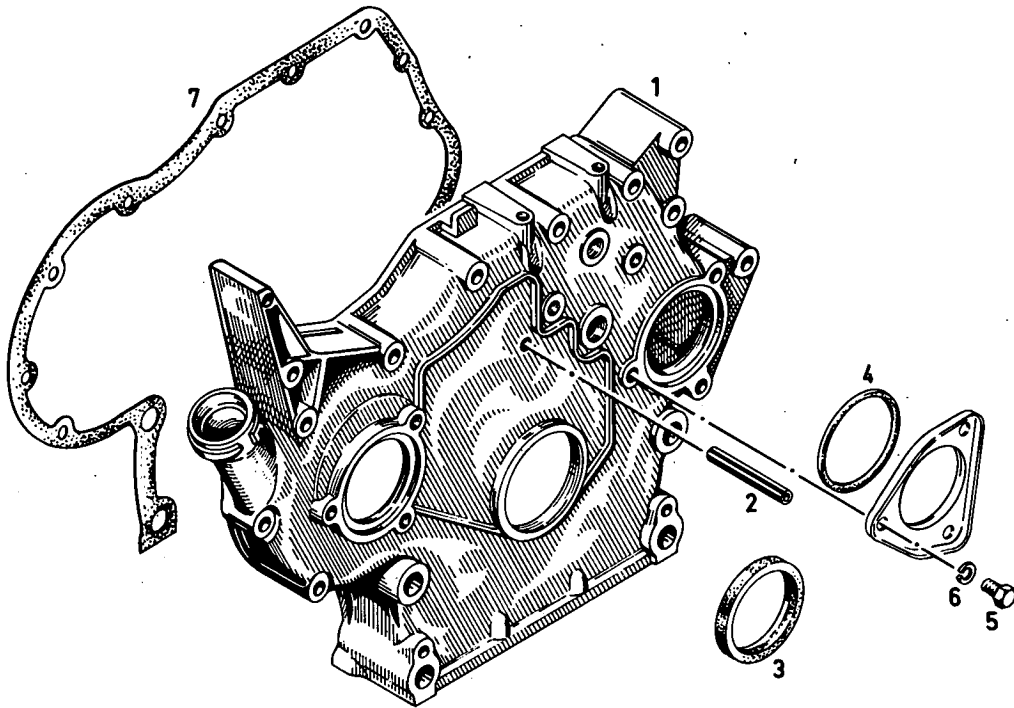
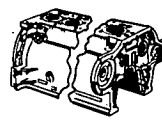

0150-01 500 4555

| Bild Nr. | Teil-Nr. | Stück-Zahl | Deutsch           | English           | Français        | Español            | Nummer/Bemerkung         | ETK |
|----------|----------|------------|-------------------|-------------------|-----------------|--------------------|--------------------------|-----|
| 1        | 213 6027 | 1          | VORDERER-DECKEL   | FRONT COVER       | COUVERCLE AV    | TAPA DELANTERA     |                          |     |
| 2        | 111 5459 | 1          | SPANNHUELSE       | DOWEL SLEEVE      | DOUILLE SERRAGE | CASQUILLO FIADOR   | 6 X 45DIN 1481           |     |
| 3        | 213 3781 | 1          | WELLENDICHTRING   | SHAFT SEAL        | JOINT D'ARBRE   | ANILLO HERMET.EJE  |                          | 01  |
| 4        | 116 6110 | 1          | RUNDGUMMRING      | O-SEAL            | ANNEAU TORIQUE  | ANILLO GOMA REDOND | 80 X 3 M 721             |     |
| 5        | 111 2295 | 1          | SECHSKANTSCHRAUBE | HEX. BOLT         | VIS 6 PANS      | TORNILLO HEXAGONAL | M 8X 10 DIN 933- 8.8-A4C |     |
| 6        | 110 2799 | 1          | FEDERRING         | SPRING LOCKWASHER | RONDELLE GROVER | ARANDELA ELASTICA  | A 8 DIN 128 A4C          |     |
| 7        | 336 2505 | 1          | DICHTUNG          | GASKET            | GARNITURE/JOINT | JUNTA              | 0150-01-54.12            | 01  |

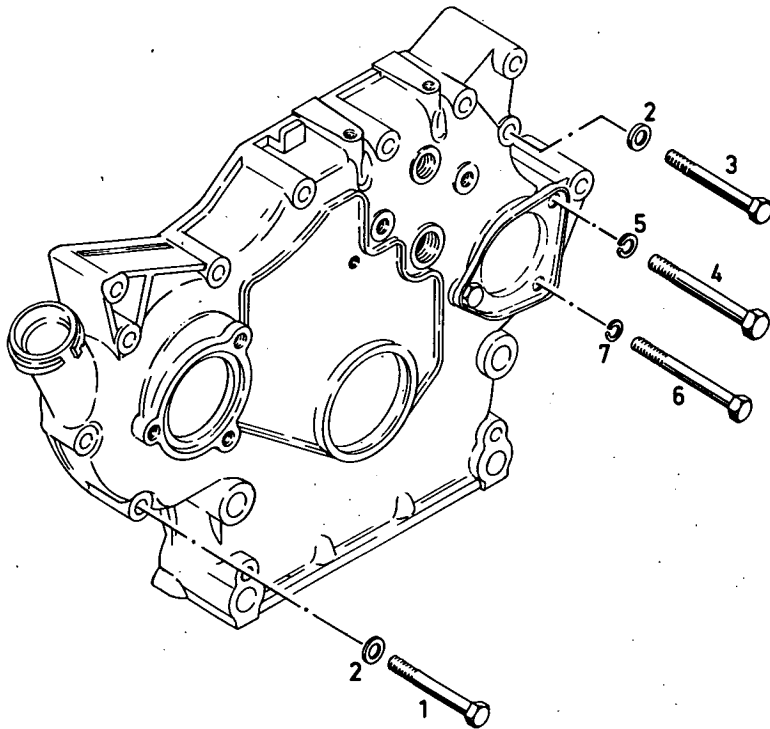

0150-01 500 6842

| Bild Nr. | Teile-Nr. | Stück-Zahl | Deutsch           | English           | Français        | Español            | Nummer / Bemerkung       | ETK |
|----------|-----------|------------|-------------------|-------------------|-----------------|--------------------|--------------------------|-----|
| 1        | 111 1166  | 2          | SECHSKANTSCHRAUBE | HEX.BOLT          | VIS 6 PANS      | TORNILLO HEXAGONAL | M 8X 60 DIN 931- 8.8     |     |
| 2        | 110 7101  | 3          | SCHEIBE           | DISC/PANE/PLATE   | RONDELLE/DISQUE | DISCO/CRISTAL/PLAT | A 8,4DIN 125-ST-A4C      |     |
| 3        | 111 1179  | 1          | SECHSKANTSCHRAUBE | HEX.BOLT          | VIS 6 PANS      | TORNILLO HEXAGONAL | M 8X 70 DIN 931- 8.8-A4C |     |
| 4        | 111 1334  | 1          | SECHSKANTSCHRAUBE | HEX.BOLT          | VIS 6 PANS      | TORNILLO HEXAGONAL | M10X 75 DIN 931- 8.8     |     |
| 5        | 110 2800  | 1          | FEDERRING         | SPRING LOCKWASHER | RONDELLE GROVER | ARANDELA ELASTICA  | A 10 DIN 128 A4C         |     |
| 6        | 111 1195  | 1          | SECHSKANTSCHRAUBE | HEX.BOLT          | VIS 6 PANS      | TORNILLO HEXAGONAL | M 8X 85 DIN 931- 8.8     |     |
| 7        | 110 2799  | 1          | FEDERRING         | SPRING LOCKWASHER | RONDELLE GROVER | ARANDELA ELASTICA  | A 8 DIN 128 A4C          |     |

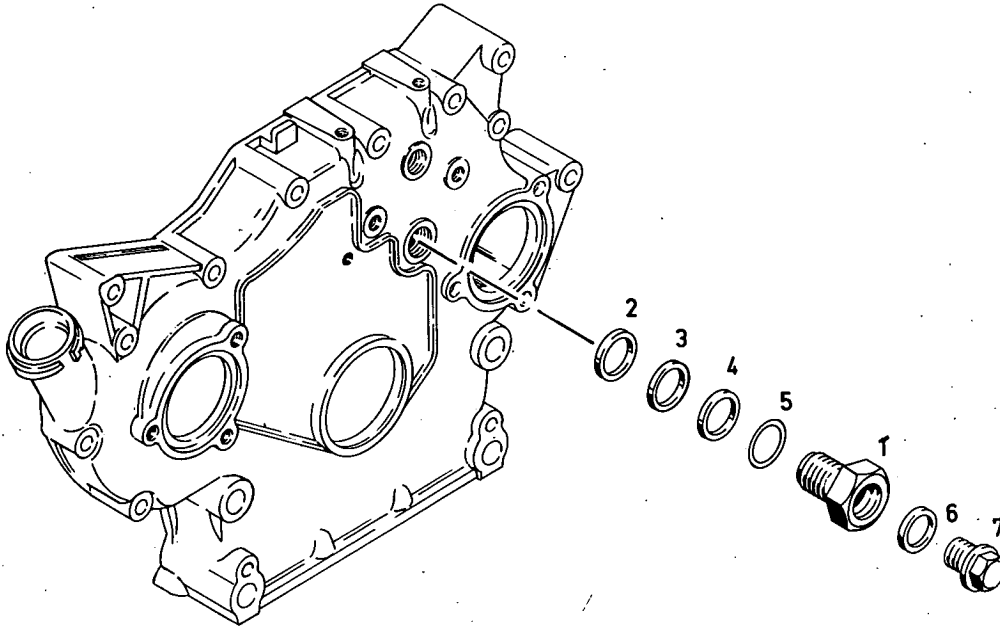
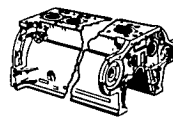

0150-01 500 3307

| Bild Nr. | Teil-Nr. | Stück-Zahl | Deutsch            | English         | Français           | Español            | Nummer / Bemerkung     | ETK |
|----------|----------|------------|--------------------|-----------------|--------------------|--------------------|------------------------|-----|
| 1        | 336 2510 | 1          | VERSCHLUSSSCHRAUBE | SCREW PLUG      | BOUCHON FILETE     | TAPON ROSCADO      | 0150-01-62.03          |     |
| 2        | 111 8750 | 1          | DICHTRING          | WASHER          | BAGUE D'ETANCHEITE | ANILLO DE JUNTA    | A 24 X 30 DIN 7603-ALU |     |
| 3        | 336 2293 | 1          | SCHEIBE            | DISC/PANE/PLATE | RONDELLE/DISQUE    | DISCO/CRISTAL/PLAT | 0150-01-07.08          |     |
| 4        | 336 2294 | 1          | SCHEIBE            | DISC/PANE/PLATE | RONDELLE/DISQUE    | DISCO/CRISTAL/PLAT | 0150-01-07.09          |     |
| 5        | 336 2295 | 2          | SCHEIBE            | DISC/PANE/PLATE | RONDELLE/DISQUE    | DISCO/CRISTAL/PLAT | 0150-01-07.11          |     |
| 6        | 111 8713 | 1          | DICHTRING          | WASHER          | BAGUE D'ETANCHEITE | ANILLO DE JUNTA    | A 18 X 22 DIN 7603-CU  |     |
| 7        | 111 8970 | 1          | VERSCHLUSSSCHRAUBE | SCREW PLUG      | BOUCHON FILETE     | TAPON ROSCADO      | AM18X1,5 DIN 7604      |     |

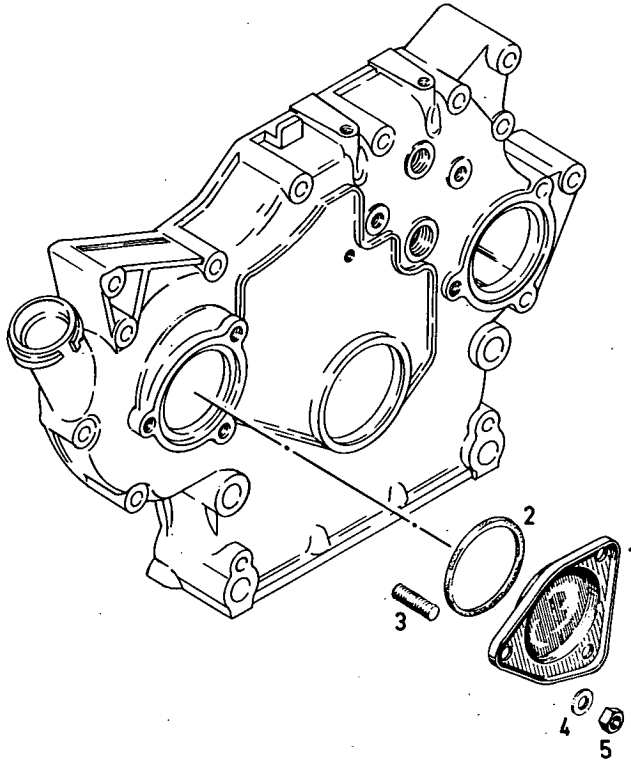
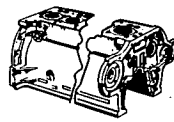

0150-01 500 3331

| Bild Nr. | Teil-Nr. | Stück-Zahl | Deutsch         | English         | Français        | Español            | Nummer/Bemerkung               | ETK |
|----------|----------|------------|-----------------|-----------------|-----------------|--------------------|--------------------------------|-----|
| 1        | 336 2504 | 1          | DECKEL          | COVER           | COUVERCLE       | TAPA               | 0150-01-54.05                  |     |
| 2        | 116 6110 | 1          | RUNDGUMMRING    | O-SEAL          | ANNEAU TORIQUE  | ANILLO GOMA REDOND | 80 X 3 H 721                   |     |
| 3        | 110 2295 | 3          | STIFTSCHRAUBE   | STUD            | GOUJON          | ESPARRAGO          | M 8 X 15 SN4 DIN 835- 6.8 VZKC |     |
| 4        | 110 7101 | 3          | SCHEIBE         | DISC/PANE/PLATE | RONDELLE/DISQUE | DISCO/CRISTAL/PLAT | A 8,4DIN 125-ST-A4C            |     |
| 5        | 111 2824 | 3          | SECHSKANTMUTTER | HEX.NUT         | ECROU 6 PANS    | TUERCA HEXAGONAL   | M 8 DIN 934-M 8 A4C            |     |

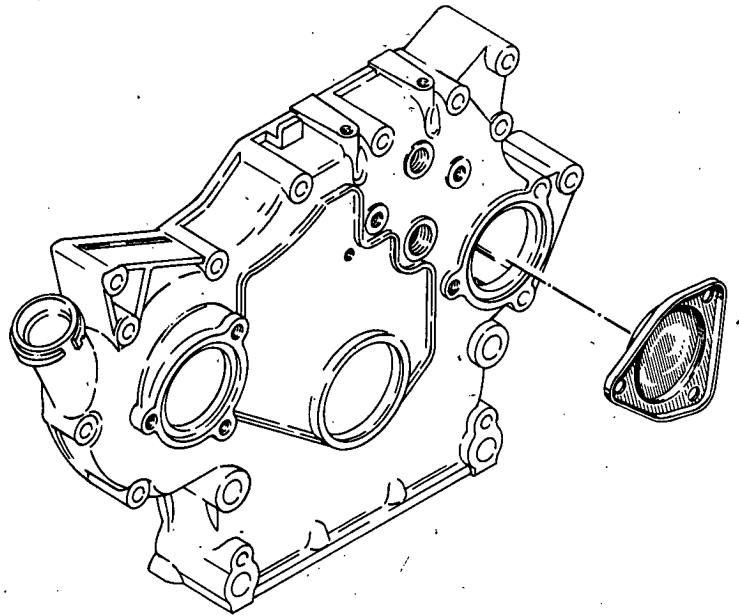
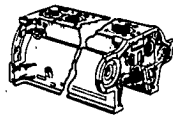

0150-01 500 3326

| Bild Nr. | Teile-Nr. | Stück-Zahl | Deutsch | English | Français  | Español | Nummer/Bemerkung | ETK |
|----------|-----------|------------|---------|---------|-----------|---------|------------------|-----|
| 1        | 336 2504  | 1          | DECKEL  | COVER   | COUVERCLE | TAPA    |                  |     |

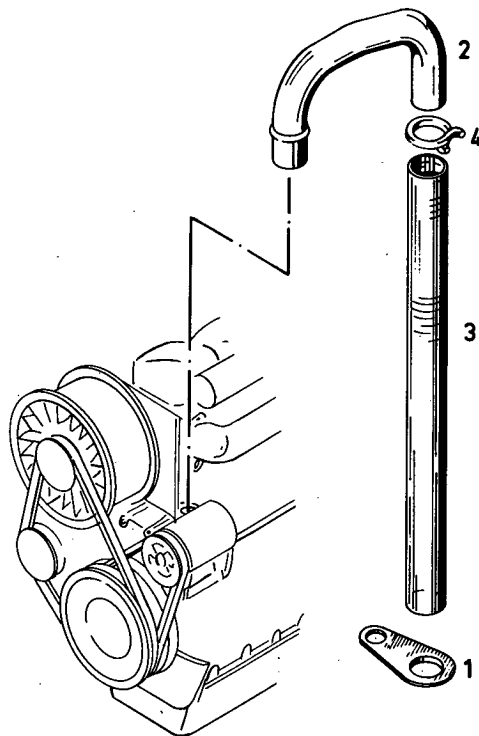
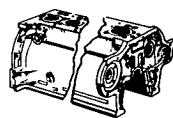

0150-01 500 3333

| Bild Nr. | Teile-Nr. | Stück-Zahl | Deutsch        | English         | Français           | Español        | Nummer/Bemerkung | ETK |
|----------|-----------|------------|----------------|-----------------|--------------------|----------------|------------------|-----|
| 1        | 210 1292  | 1          | HALTEBLECH     | RETAINING PLATE | TOLE DE RETENUE    | CHAPA SUJECION | 0150-01-416.04   |     |
| 2        | 210 1937  | 1          | ROHR           | PIPE/TUBE       | TUBE/TUYAU         | TUBO           | 0150-01-416.01   |     |
| 3        | 210 2046  | 1          | SCHLAUCH       | HOSE            | FLEXIBLE           | MANGUERA       | 0150-01-416.03   |     |
| 4        | 116 3942  | 1          | SCHLAUCHKLEMME | HOSE CLIP       | COLLIER A FLEXIBLE | PINZA MANGUERA | SK 33 H 735      |     |

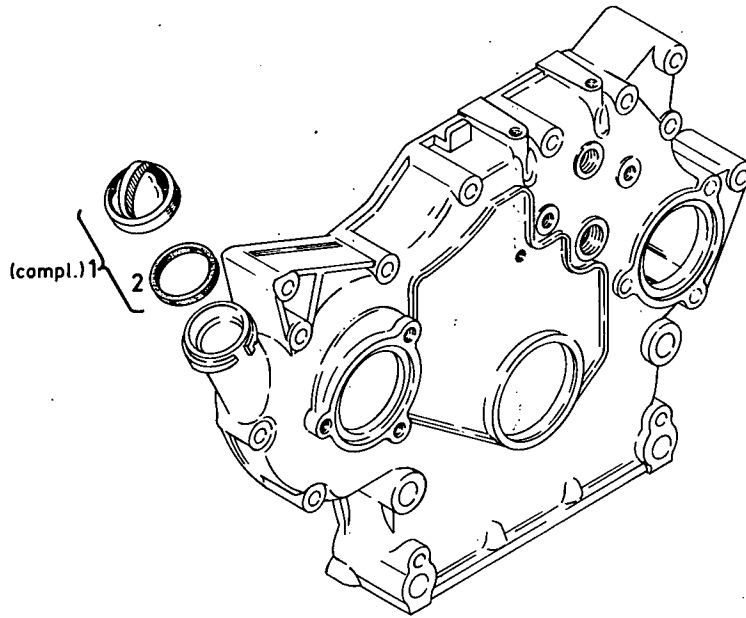
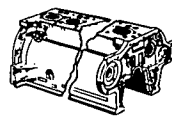

0150-01 500 3320

| Bild Nr. | Teile-Nr. | Stück-Zahl | Deutsch   | English | Français           | Español         | Nummer/Bemerkung | ETK |
|----------|-----------|------------|-----------|---------|--------------------|-----------------|------------------|-----|
| 1        | 123 6291  | 1          | DECKEL    | COVER   | COUVERCLE          | TAPA            | 8928-75-007.010  |     |
| 2        | 123 6290  | 1          | DICHTRING | WASHER  | BAGUE D'ETANCHEITE | ANILLO DE JUNTA | 8928-75-007.002  | 01  |



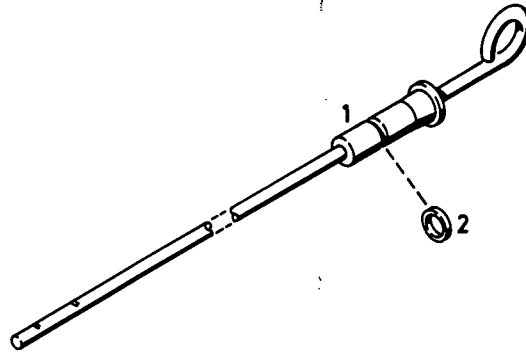
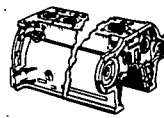

| Bild Nr. | Teile-Nr. | Stück-Zahl | Deutsch       | English      | Français       | Español            | 0150-01 500 4439<br>Nummer/Bemerkung | ETK |
|----------|-----------|------------|---------------|--------------|----------------|--------------------|--------------------------------------|-----|
| 1        | 336 2499  | 1          | ÖLMESSSTAB    | OIL DIPSTICK | JAUGE D'HUILE  | VARIL.NIVEL ACEITE | 0150-01-52.280                       |     |
| 2        | 116 5975  | 1          | RUNDGUMMIRING | O-SEAL       | ANNEAU TORIQUE | ANILLO GOMA REDOND | 5 X 2 H 721                          | 01  |

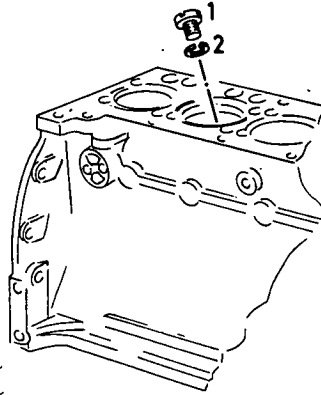
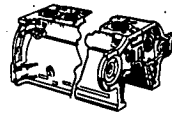

0150-01 500 6781

| Bild Nr. | Teile-Nr. | Stück-Zahl | Deutsch           | English           | Français        | Español           | Nummer / Bemerkung | ETK |
|----------|-----------|------------|-------------------|-------------------|-----------------|-------------------|--------------------|-----|
| 1        | 213 0507  | 1          | VERSCHLUSSSTOPFEN | NIPPLE            | BOUCHON         | TAPON OBTURADOR   |                    |     |
| 2        | 111 9611  | 1          | FEDERRING         | SPRING LOCKWASHER | RONDELLE GROWER | ARANDELA ELASTICA | 8 DIN 7980 VZKC    |     |

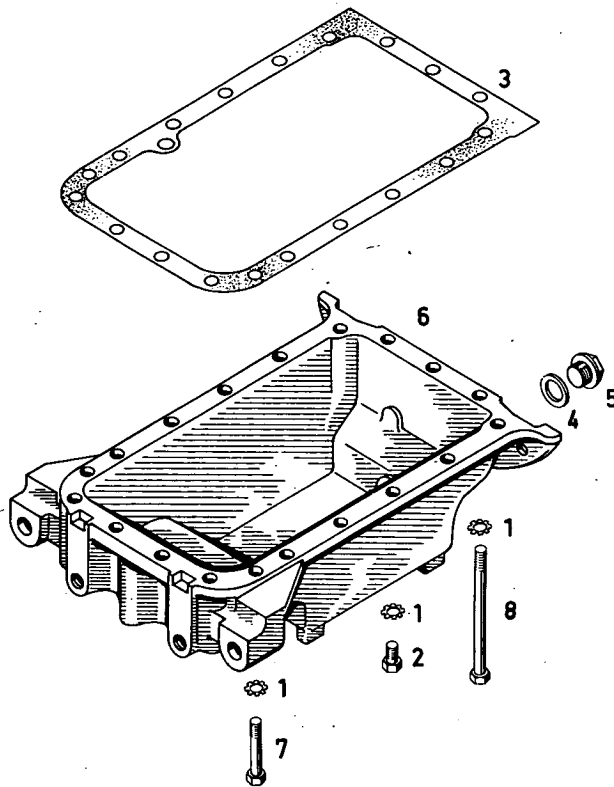
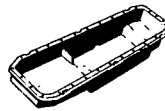

0150-02 500 6742

| Bild Nr. | Teile-Nr. | Stück-Zahl | Deutsch            | English        | Français           | Español            | Nummer/Bemerkung         | ETK |
|----------|-----------|------------|--------------------|----------------|--------------------|--------------------|--------------------------|-----|
| 1        | 110 1490  | 19         | ZAHNSCHEIBE        | TOOTHED WASHER | RONDELLE DENTÉE    | ARANDELA DENTADA   | A 8,2 DIN 6797           |     |
| 2        | 111 2337  | 12         | SECHSKANTSCHRAUBE  | HEX. BOLT      | VIS 6 PANS         | TORNILLO HEXAGONAL | M 8 X 30 DIN 933- 8.8    |     |
| 3        | 336 2573  | 1          | DICHTUNG           | GASKET         | GARNITURE/JOINT    | JUNTA              | 0150-02-01.02            | 01  |
| 4        | 111 8783  | 1          | DICHTRING          | WASHER         | BAGUE D'ÉTANCHEITE | ANILLO DE JUNTA    | A 30 X 36 DIN 7603-ALU   | 01  |
| 5        | 111 8989  | 1          | VERSCHLUSSSCHRAUBE | SCREW PLUG     | BOUCHON FILETÉ     | TAPON ROSCADO      | M 30 X 1,5 DIN 7604 VZKC | 01  |
| 6        | 210 1390  | 1          | ÖLWANNE            | OIL SUMP       | CUVE A HUILE       | SUMIDERO ACEITE    | 0150-02-18.26            |     |
| 7        | 111 1151  | 2          | SECHSKANTSCHRAUBE  | HEX. BOLT      | VIS 6 PANS         | TORNILLO HEXAGONAL | M 8 X 45 DIN 931- 8.8    |     |
| 8        | 111 1212  | 5          | SECHSKANTSCHRAUBE  | HEX. BOLT      | VIS 6 PANS         | TORNILLO HEXAGONAL | M 8 X 110 DIN 931- 8.8   |     |

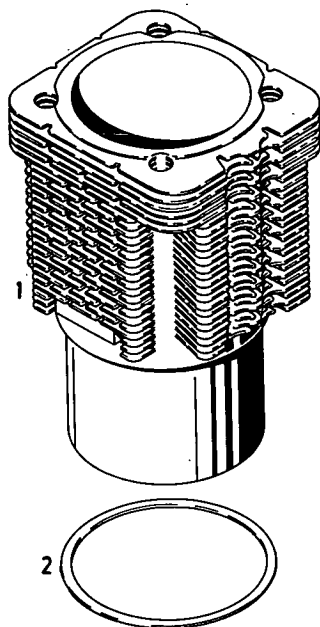

0150-04 500 3353

| Bild Nr. | Teile-Nr. | Stück-Zahl | Deutsch       | English      | Français         | Español          | Nummer/Bemerkung                 | ETK |
|----------|-----------|------------|---------------|--------------|------------------|------------------|----------------------------------|-----|
| 1        | 213 7828  | 1          | ZYLINDER      | CYLINDER/RAM | CYLINDRE         | CILINDRO         | WW PDS.950                       | 01  |
| 2        | 213 7256  | NB         | AUSGLEICHRING | SHIM         | ANNEAU COMPENSAT | ARO COMPENSACION |                                  | 01  |
| 950      | 210 1175  | 1          | ZYLINDER      | CYLINDER/RAM | CYLINDRE         | CILINDRO         | 0155-04-11.01<br>WAHLWEISE PDS.1 |     |

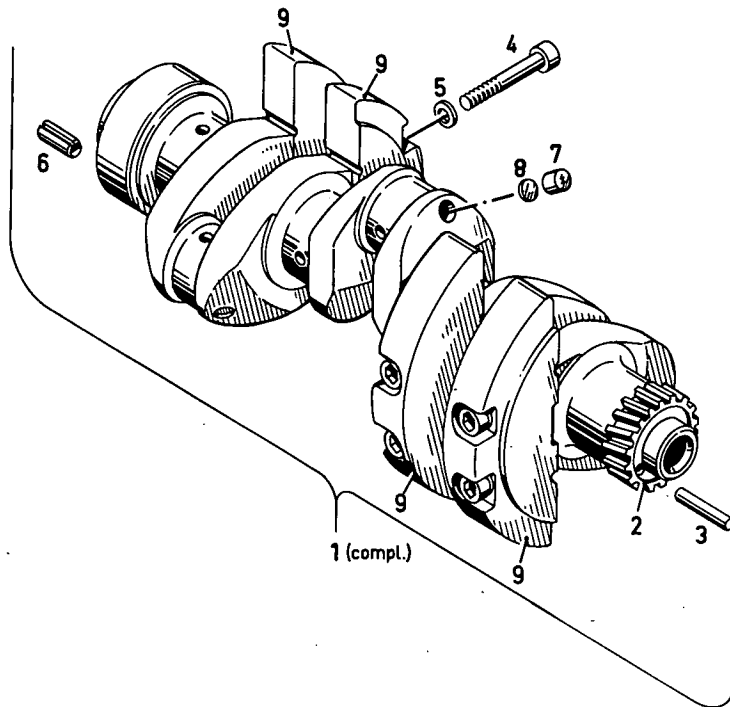

| Bild Nr | Teile-Nr. | Stück-Zahl | Deutsch          | English           | Français          | Español            | 0150-05 500 6730<br>Nummer/Bemerkung | ETP |
|---------|-----------|------------|------------------|-------------------|-------------------|--------------------|--------------------------------------|-----|
| 1       | 213 6928  | 1          | KURBELWELLE      | CRANKSHAFT        | VILEBREQUIN       | CIGUENAL           |                                      |     |
| 2       | 336 2737  | 1          | ZAHNRAD          | GEAR              | ROUE DENTEE       | RUEDA DENTADA      | 0150-05-16.14                        |     |
| 3       | 110 5166  | 1          | ZYLINDERSTIFT    | PARALLEL PIN      | GOUPILLE CYLINDR. | PERNO CILINDRICO   | 8 M 6X 45DIN 7                       |     |
| 4       | 112 4778  | 8          | ZYLINDERSCHRAUBE | CHEESE-HEAD SCREW | VIS TETE CYLINDR. | TORN.CBZA.CILIND.  | M12X 60DIN 912-10.9 A4C              |     |
| 5       | 121 6119  | 8          | SCHEIBE          | DISC/PANE/PLATE   | RONDELLE/DISQUE   | DISCO/CRISTAL/PLAT | 2 308 A 29                           |     |
| 6       | 111 5464  | 1          | SPANNHUELSE      | DOWEL SLEEVE      | DOUILLE SERRAGE   | CASQUILLO FIADOR   | 8 X 18DIN 1481                       |     |
| 7       | 117 0580  | 3          | STOPFEN          | PLUG              | BOUCHON           | TAPDN              | A 8 H 2855                           |     |
| 8       | 116 7010  | 3          | SCHEIBE          | DISC/PANE/PLATE   | RONDELLE/DISQUE   | DISCO/CRISTAL/PLAT | A 7,5X 1 H 984                       |     |
| 9       | 223 0134  | 4          | BEGENGEWICHT     | COUNTERWEIGHT     | CONTRE-POIDS      | CONTRAPESO         |                                      |     |

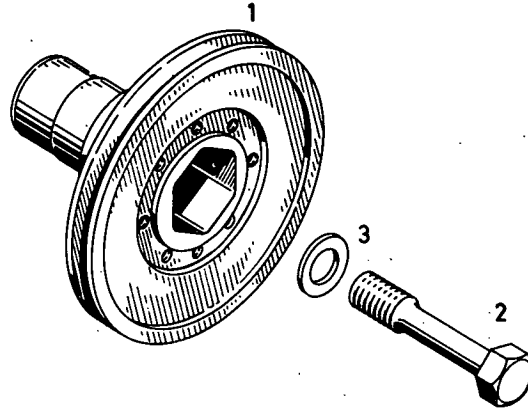

0150-05 500 4550

| Bild Nr. | Teile-Nr. | Stück-Zahl | Deutsch            | English         | Français          | Español              | Nummer/Bemerkung           | ETK |
|----------|-----------|------------|--------------------|-----------------|-------------------|----------------------|----------------------------|-----|
| 1        | 213 4336  | 1          | KEILRIEMENSCHLEIBE | V-BELT PULLE    | POULIE COURR TRAP | POLEA ACANALADA      |                            |     |
| 2        | 116 6951  | 1          | SKT. DEHNSCHRAUBE  | WAISTED BOLT    | VIS EXTENS 6 PANS | TORN. HEX. EXPANSION | M24X2 LINKSX110 H 803-10.9 |     |
| 3        | 121 6128  | 1          | SCHLEIBE           | DISC/PANE/PLATE | RONDELLE/DISQUE   | DISCO/CRISTAL/PLAT   | 2 308 A 40                 |     |

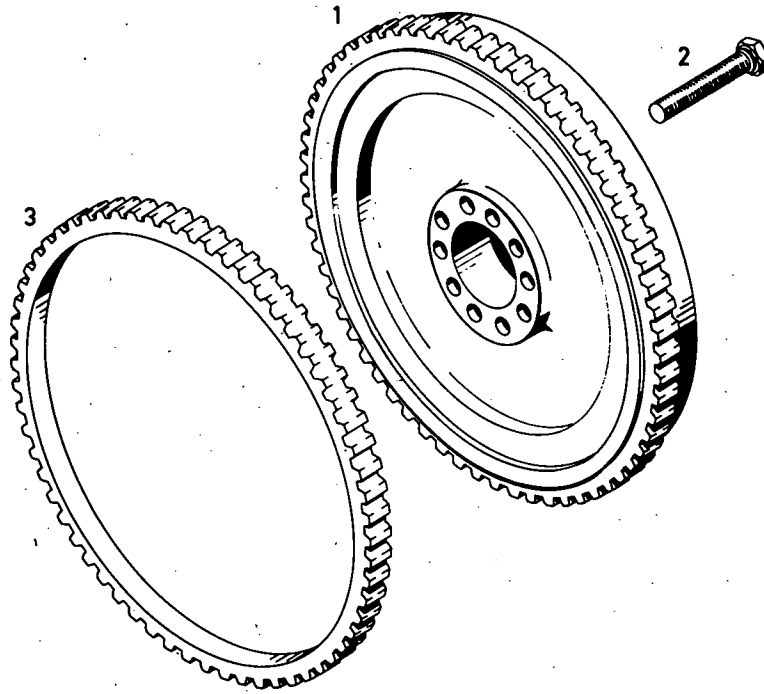

0150-05 500 6903

| Bild Nr. | Teile-Nr. | Stück-Zahl | Deutsch           | English   | Français        | Español            | Nummer/Bemerkung         | ETK |
|----------|-----------|------------|-------------------|-----------|-----------------|--------------------|--------------------------|-----|
| X 1      | 216 8371  | 1          | SCHWUNGRAD        | FLYWHEEL  | VOLANT          | VOLANTE            | MIT BILD NR. 3           |     |
| 2        | 110 4845  | 10         | SECHSKANTSCHRAUBE | HEX.BOLT  | VIS 6 PANS      | TORNILLO HEXAGONAL | M10X135 DIN 961-10.9-A4C |     |
| 3        | 213 1081  | 1          | ZAHNKRANZ         | RING GEAR | COURONNE DENTEE | CORONA DENTADA     |                          |     |

X wird nur einzeln geliefert  
Schwungrad = 216 8724  
Zahnkranz = 213 1081



Pleuelstange  
Connecting rod  
Bielle  
Biela

Stück/Zyl.-Einheit  
Pieces/cyl. unit  
Qté/cylindre  
Cantid./unid. cilind.



0150-06-500 4310

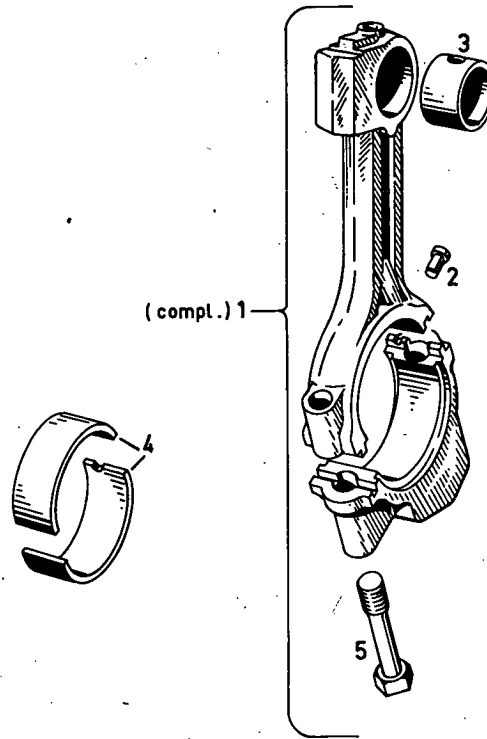

0150-06 500 4310

| Bild Nr. | Teile-Nr. | Stück-Zahl | Deutsch          | English         | Français          | Español            | Nummer/Bemerkung  | ETK |
|----------|-----------|------------|------------------|-----------------|-------------------|--------------------|---|-----|
| 1        | 213 6526  | 1          | PLEUELSTANGE     | CONNECTING ROD  | BIELLE            | BIELA              |   |     |
| 2        | 213 6101  | 1          | STIFT            | PIN             | CHEVILLE/GOUPILLE | PERNO/PASADOR      |   | 01  |
| 3        | 337 1612  | 1          | KOLBENBUCHSE     | BARREL          | CYL DE PLONGEUR   | CASO.EMBLO/PISTON  | 0155-06-05.05   | 01  |
| 4        | 213 7750  | 1          | PLEUELLAGER      | BIG-END BEARING | COUSS TETE BIELLE | COJINETE BIELA     | NORMAL 60,00MM RD(2,3622 IN.)<br>UNTERMASST.POS.950-955 | 01  |
| 5        | 213 3871  | 2          | SKT.DEHNSCHRAUBE | WAISTED BOLT    | VIS EXTENS 6 PANS | TORN.HEX.EXPANSION |   | 01  |
| 950      | 213 7754  | NB         | PLEUELLAGER      | BIG-END BEARING | COUSS TETE BIELLE | COJINETE BIELA     | 1.UNTERMASST.59,75MM RD<br>(2,3523 IN.)                 |     |
| 951      | 213 7758  | NB         | PLEUELLAGER      | BIG-END BEARING | COUSS TETE BIELLE | COJINETE BIELA     | 2.UNTERMASST.59,50MM RD<br>(2,3425 IN.)                 |     |
| 952      | 213 7762  | NB         | PLEUELLAGER      | BIG-END BEARING | COUSS TETE BIELLE | COJINETE BIELA     | 3.UNTERMASST.59,25MM RD<br>(2,3327 IN.)                 |     |
| 953      | 213 7766  | NB         | PLEUELLAGER      | BIG-END BEARING | COUSS TETE BIELLE | COJINETE BIELA     | 4.UNTERMASST.59,00MM RD<br>(2,3228 IN.)                 |     |
| 954      | 213 7770  | NB         | PLEUELLAGER      | BIG-END BEARING | COUSS TETE BIELLE | COJINETE BIELA     | 5.UNTERMASST.58,75MM RD<br>(2,3130 IN.)                 |     |
| 955      | 213 7774  | NB         | PLEUELLAGER      | BIG-END BEARING | COUSS TETE BIELLE | COJINETE BIELA     | 6.UNTERMASST.58,50MM RD<br>(2,3031 IN.)                 |     |



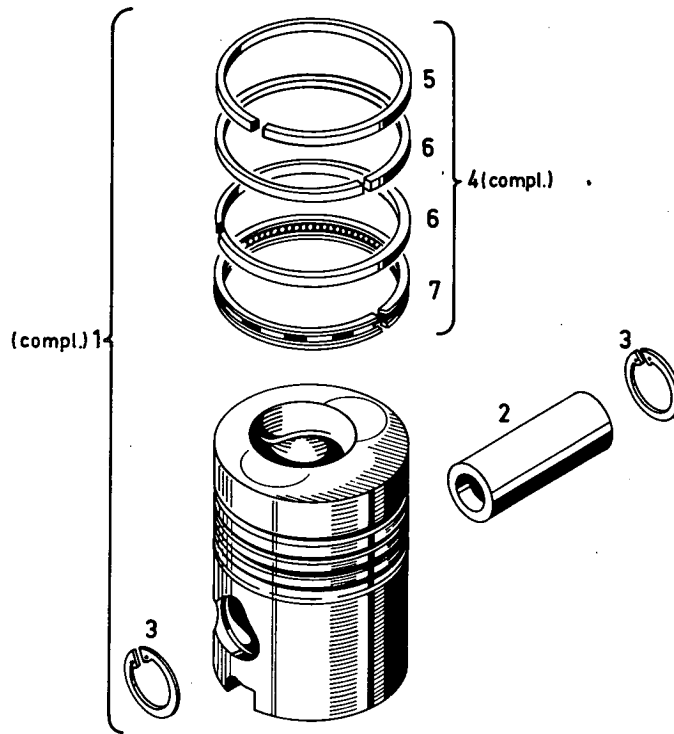

| Bld Nr. | Teile-Nr. | Stück-Zahl | Deutsch        | English          | Français           | Español            | 0150-07 500 3387<br>Nummer/Bemerkung   | ETK |
|---------|-----------|------------|----------------|------------------|--------------------|--------------------|--|-----|
| 1       | 213 6952  | 1          | KOLBEN         | PISTON/PLUNGER   | PISTON             | EMBOLO/PISTON      | NORMAL 100,00MM RD(3,9370IN.)<br>UEBERMASSTUFE POS.950                               | 01  |
| 2       | 337 1660  | 1          | KOLBENBOLZEN   | PISTON PIN       | AXE DE PISTON      | PERNO DE EMBOLO    | 0155-07-10.22  |     |
| 3       | 110 7821  | 2          | SICHERUNGSRING | CIRCLIP          | CIRCLIP            | CIRCLIP            | 35X1,5 DIN 472   |     |
| 4       | 213 3807  | SZ         | KOLBENRING     | PISTON RING      | SEGMENT PISTON     | ARD EMBOLO/PISTON  | NORMAL 100,00MM RD(3,9370IN.)<br>UEBERMASSTUFE POS.951                               | 01  |
| 5       | 116 2303  | 1          | TRAPEZRING     | TRAPEZOIDAL RING | SEGMENT TRAPEZ.    | ANIL.SECC.TRAPEC.  | D 100 X 91,4X3 H 2962 K-CR<br>NORMAL 100,00MM RD(3,9370IN.)<br>UEBERMASSTUFE POS.952 |     |
| 6       | 116 1084  | 2          | MINUTENRING    | TAPERED RING     | SEGM BISEAUTE      | ARD BISELADO       | 100 X 91,4X 2,5H 2959 FE<br>NORMAL 100,00MM RD(3,9370IN.)<br>UEBERMASSTUFE POS.953   |     |
| 7       | 116 1089  | 1          | DELSCHLITZRING | OIL CONTRDL RING | SEG RACL HLE A LUM | AN.RANUR.RASPAACTE | SF 100 X 90,9X 5 H 2984 CR<br>NORMAL 100,00MM RD(3,9370IN.)<br>UEBERMASSTUFE POS.954 |     |
| 950     | 213 6953  | 1          | KOLBEN         | PISTON/PLUNGER   | PISTON             | EMBOLO/PISTON      | 1.UEBERMASSTUFE 100,50 MM RD<br>(3,9567 IN.)   |     |
| 951     | 223 0292  | SZ         | KOLBENRING     | PISTON RING      | SEGMENT PISTON     | ARD EMBOLO/PISTON  | 1.UEBERMASSTUFE 100,50 MM RD<br>(3,9567IN.)  |     |
| 952     | 116 2467  | 1          | TRAPEZRING     | TRAPEZOIDAL RING | SEGMENT TRAPEZ.    | ANIL.SECC.TRAPEC.  | D 100,5X 91,9X3 H 2962 K-CR<br>1.UEBERMASSTUFE 100,50 MM RD<br>(3,9567 IN.)          |     |
| 953     | 116 2104  | 2          | MINUTENRING    | TAPERED RING     | SEGM BISEAUTE      | ARD BISELADO       | 100,5X 91,9X 2,5H 2959 FE<br>1.UEBERMASSTUFE 100,50 MM RD<br>(3,9567IN.)             |     |
| 954     | 116 2103  | 1          | DELSCHLITZRING | OIL CONTRDL RING | SEG RACL HLE A LUM | AN.RANUR.RASPAACTE | SF 100,5X 91,4X 5 H 2984 CR<br>1.UEBERMASSTUFE 100,50 MM RD<br>(3,9567 IN.)          |     |
| 955     | 223 1467  | 1          | KOLBEN         | PISTON/PLUNGER   | PISTON             | EMBOLO/PISTON      | 2.UEBERMASST. 101,00MM RD<br>(3,9764 IN.)  |     |
| 956     | 223 1470  | SZ         | KOLBENRING     | PISTON RING      | SEGMENT PISTON     | ARD EMBOLO/PISTON  | 2.UEBERMASST. 101,00MM RD<br>(3,9764 IN.)  |     |

| Bid Nr. | Teile-Nr. | Stück-Zahl | Deutsch        | English          | Français           | Español            | Nummer/Bemerkung  | ETK |
|---------|-----------|------------|----------------|------------------|--------------------|--------------------|---|-----|
| 957     | 117 2312  | 1          | TRAPEZRING     | TRAPEZOIDAL RING | SEGMENT TRAPEZ.    | ANIL.SECC.TRAPEC.  | D 101 X 92,4X3 H 2962 K-CR<br>2.UEBERMASST. 101,00MM RD<br>(3,9764 IN.) |     |
| 958     | 117 2311  | 2          | MINUTENRING    | TAPERED RING     | SEGM BISEAUTE      | ARD BISELADO       | 101 X 92,4X 2,5H 2959-FE<br>2.UEBERMASST. 101,00MM RD<br>(3,9764 IN.)   |     |
| 959     | 117 2313  | 1          | DELSCHLITZRING | OIL CONTROL RING | SEG RACL HLE A LUM | AN.RANUR.RASPAACTE | SF 101 X 91,9X 5 H 2984 CR<br>2.UEBERMASST.101,00MM RD<br>(3,9764 IN.)  |     |

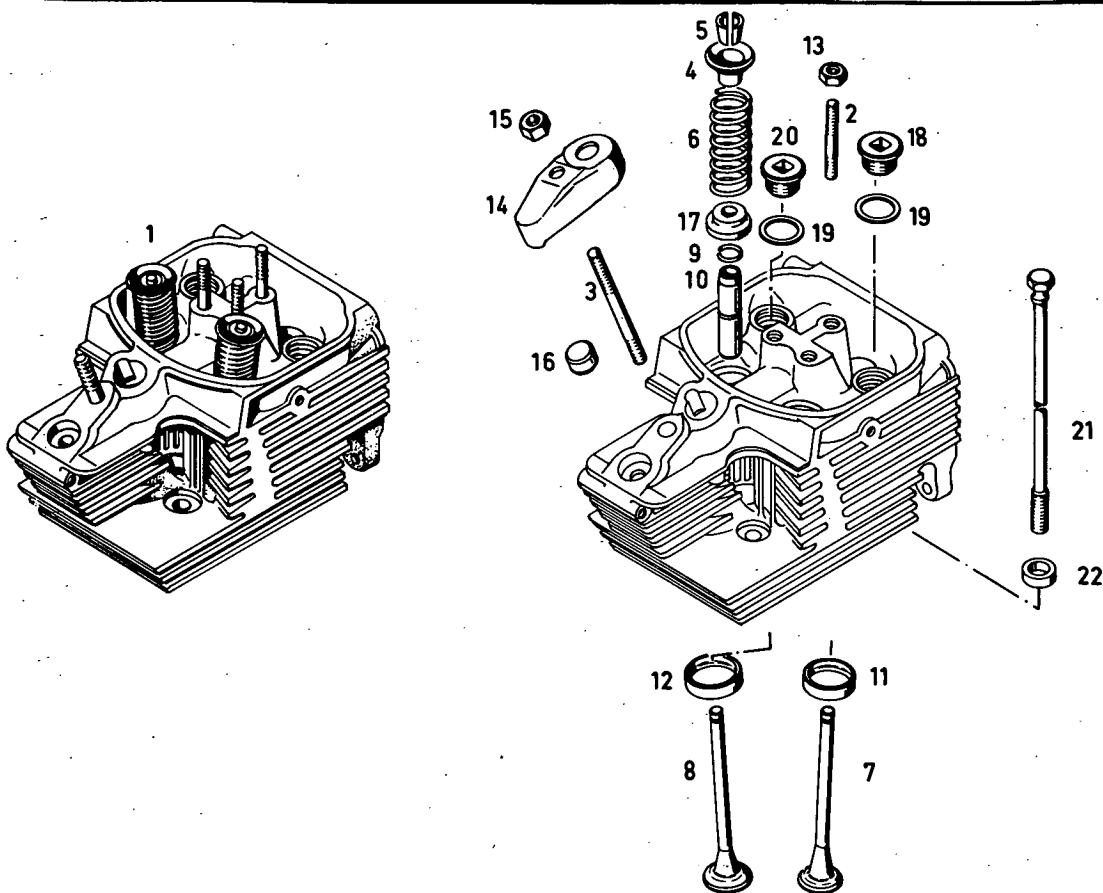

0150-08 500 6876

| Bild Nr. | Teile-Nr. | Stück-Zahl | Deutsch            | English            | Français           | Español            | Nummer / Bemerkung  | ETK |
|----------|-----------|------------|--------------------|--------------------|--------------------|--------------------|---|-----|
| 1        | 223 1154  | 1          | ZYLINDERKOPF       | CYLINDER HEAD      | CULASSE            | CULATA CILINDRO    | MONTAGETEIL   | 01  |
| 2        | 110 2046  | 3          | SCHRAUBE           | SCREW/BOLT         | VIS/BOULON         | TORNILLO           | M 8 X 55 S4 DIN 835- 8.8  |     |
| 3        | 111 0254  | 1          | SCHRAUBE           | SCREW/BOLT         | VIS/BOULON         | TORNILLO           | M10 X 65 S4 DIN 835- 6.8  |     |
| 4        | 337 1748  | 2          | FEDERTELLER        | SPRING CAP         | CUVETTE DE RESSORT | PLATO RESORTE      | 0155-08-45.23   | 01  |
| 5        | 116 8817  | 4          | VENTILKEGEL        | VALVE CONE         | CONE DE SOUPEPE    | CONO DE VALVULA    | 8H 7020   | 01  |
| 6        | 336 9305  | 2          | DRUCKFEDER         | COMPRESSION SPRING | RESSORT DE COMPR   | RESORTE PRESION    | 0154-08-42.28   | 01  |
| 7        | 213 7300  | 1          | AUSLASSVENTIL      | EXHAUST VALVE      | SOUPEPE D'ECHAPP.  | VALV.ESCAPE        |   | 01  |
| 8        | 213 7301  | 1          | EINLASSVENTIL      | INLET VALVE        | SOUP D'ADMISSION   | VALV.ADNIS.        |   | 01  |
| 9        | 121 5500  | 2          | SPRENGRING         | SNAP RING          | AGRAFE-CIRCULAIRE  | ANILLO RETENCION   | 951 K 4   |     |
| 10       | 337 1761  | 2          | VENTILFUEHRUNG     | VALVE GUIDE        | GUIDE DE SOUPEPE   | GUITA DE VALVULA   | 0195-08-50.04   |     |
| 11       | 213 7306  | 1          | VENTILSITZRING     | SEAT INSERT RING   | BAGUE-SIEGE SOUP.  | ANILLO ASIENT.VALV | FUER AUSL.NORMAL 40,16MM RD<br>(1.5811 IN.)UEB.M.POS.952-954                  |     |
| 12       | 213 7302  | 1          | VENTILSITZRING     | SEAT INSERT RING   | BAGUE-SIEGE SOUP.  | ANILLO ASIENT.VALV | 0155-08-51.02<br>F.EINLASS NDRMAL 45,66MM RD<br>(1.7976 IN.)UEB.M.POS.955-957 |     |
| 13       | 111 2824  | 3          | SECHSKANTMUTTER    | HEX.NUT            | ECROU 6 PANS       | TUERCA HEXAGONAL   | M8 DIN 934-M8-A4C   |     |
| 14       | 213 7591  | 1          | BUEGEL             | YOKE/RETAINER      | ETRIER             | ESTRIBO            |   |     |
| 15       | 110 2659  | 1          | SECHSKANTMUTTER    | HEX.NUT            | ECROU 6 PANS       | TUERCA HEXAGONAL   | M 10 DIN 934-M8-A4C   |     |
| 16       | 213 7580  | 1          | SCHLEIBE           | DISC/PANE/PLATE    | RONDELLE/DISQUE    | DISCO/CRISTAL/PLAT |   |     |
| 17       | 213 7096  | 2          | FEDERTELLER        | SPRING CAP         | CUVETTE DE RESSORT | PLATO RESORTE      |   |     |
| 18       | 213 6596  | 1          | VERSCHLUSSSCHRAUBE | SCREW PLUG         | BOUCHON FILETE     | TAPON ROSCADO      |   |     |
| 19       | 111 8760  | 2          | DICHRING           | WASHER             | BAGUE D'ETANCHEITE | ANILLO DE JUNTA    | A 26 X 31 DIN 7603-CU   |     |
| 20       | 213 6596  | 1          | VERSCHLUSSSCHRAUBE | SCREW PLUG         | BOUCHON FILETE     | TAPON ROSCADO      |   |     |
| 21       | 210 1681  | 4          | SKT.DEHNSCHRAUBE   | WAISTED BOLT       | VIS EXTENS 6 PANS  | TORN.HEX.EXPANSION | 0155-08-51.17   | 01  |
| 22       | 337 1666  | 4          | UNTERLEGSCHLEIBE   | WASHER             | RONDELLE           | ARANDELA CALCE     | 0155-08-03.28   |     |
| 952      | 213 7307  | 1          | VENTILSITZRING     | SEAT INSERT RING   | BAGUE-SIEGE SOUP.  | ANILLO ASIENT.VALV | FUER AUSL.1.UEBERMASST.<br>40,26MM RD (1.5850 IN.)                            |     |

| Bild Nr. | Teil-Nr. | Stück-Zahl | Deutsch        | English          | Français          | Español             | Nummer/Bemerkung                                    | ETK |
|----------|----------|------------|----------------|------------------|-------------------|---------------------|---|-----|
| 953      | 213 7308 | 1          | VENTILSITZRING | SEAT INSERT RING | BAGUE-SIEGE SOUP. | ANILLO ASIEN.T.VALV | FUER AUSL.2.UEBERMASST.<br>40,36MM RD (1.5890 IN.)  |     |
| 954      | 213 7309 | 1          | VENTILSITZRING | SEAT INSERT RING | BAGUE-SIEGE SOUP. | ANILLO ASIEN.T.VALV | FUER AUSL.3.UEBERMASST.<br>40,46 MM RD (1.5929 IN.) |     |
| 955      | 213 7303 | 1          | VENTILSITZRING | SEAT INSERT RING | BAGUE-SIEGE SOUP. | ANILLO ASIEN.T.VALV | FUER EINL.1.UEBERMASST.<br>45,76MM RD (1.8016 IN.)  |     |
| 956      | 213 7304 | 1          | VENTILSITZRING | SEAT INSERT RING | BAGUE-SIEGE SOUP. | ANILLO ASIEN.T.VALV | FUER EINL.2.UEBERMASST.<br>45,86MM RD (1.8055 IN.)  |     |
| 957      | 213 7305 | 1          | VENTILSITZRING | SEAT INSERT RING | BAGUE-SIEGE SOUP. | ANILLO ASIEN.T.VALV | FUER EINL.3.UEBERMASST.<br>45,96MM RD (1.8094 IN.)  |     |



Zylinderkopfhaube  
 Rocker chamber cover  
 Culasse  
 Caperuza de culata

Stück/Zyl.-Einheit  
 Pieces/cyl. unit  
 Qté/cylindre  
 Cantid./unid. cilind.



0150-08-500 6586

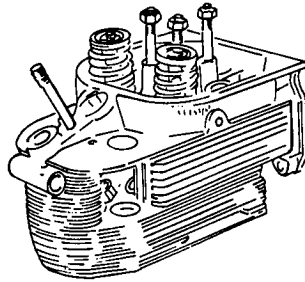
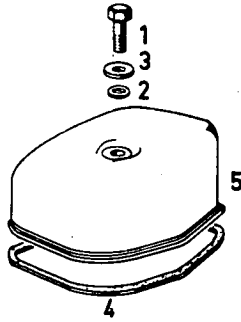

| Bild<br>Nr. | Teile-Nr. | Stück-<br>Zahl | 0150-08 500 6586  |                 |                    |                    | Nummer/Bemerkung         | ETK |
|-------------|-----------|----------------|-------------------|-----------------|--------------------|--------------------|--------------------------|-----|
|             |           |                | Deutsch           | English         | Français           | Español            |                          |     |
| 1           | 111 1132  | 1              | SECHSKANTSCHRAUBE | HEX. BOLT       | VIS 6 PANS         | TORNILLO HEXAGONAL | M 8X 30 DIN 931- 8.8-A4C |     |
| 2           | 121 6307  | 1              | DICHTRING         | WASHER          | BAGUE D'ETANCHEITE | ANILLO DE JUNTA    | 2 914 A 8                | 01  |
| 3           | 110 7101  | 1              | SCHEIBE           | DISC/PANE/PLATE | RONDELLE/DISQUE    | DISCO/CRISTAL/PLAT | A 8,4DIN 125-ST-A4C      |     |
| 4           | 337 1692  | 1              | DICHTUNG          | GASKET          | GARNITURE/JOINT    | JUNTA              | 0155-08-22.05            | 01  |
| 5           | 213 5910  | 1              | ZYLINDERKOPFHAUBE | COVER           | CHAPEAU DE CULASSE | CAPERUZA CULATA    |                          |     |

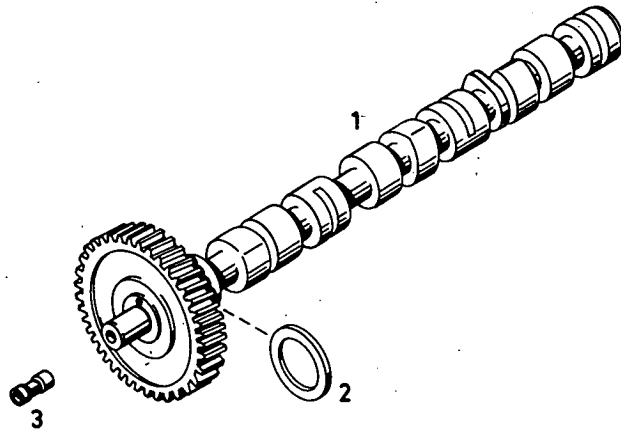

0150-10 500 6862

| Bild Nr. | Teile-Nr. | Stück-Zahl | Deutsch     | English         | Français        | Español            | Nummer/Bemerkung | ETK |
|----------|-----------|------------|-------------|-----------------|-----------------|--------------------|------------------|-----|
| 1        | 210 1222  | 1          | NOCKENWELLE | CAMSHAFT        | ARBRE A CAMES   | ARBOL DE LEVAS     | 0150-10-02.140   |     |
| 2        | 336 7789  | 1          | SCHEIBE     | DISC/PANE/PLATE | RONDELLE/DISQUE | DISCO/CRISTAL/PLAT | 0153-10-01.16    |     |
| 3        | 121 6884  | 1          | BUECHSE     | BUSH            | BOITE           | CASQUILLO          | 4 217 A          |     |

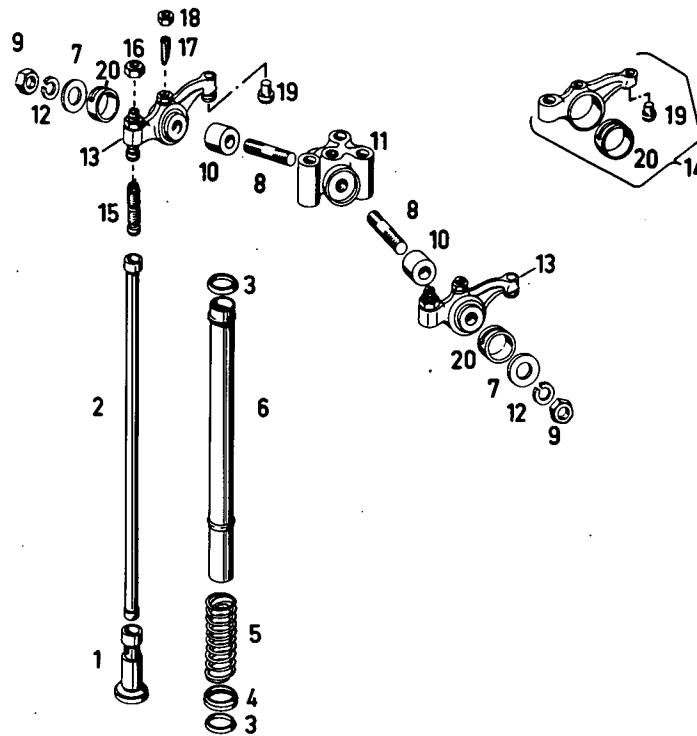
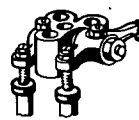

| Bild Nr. | Teile-Nr. | Stück-Zahl | Deutsch          | English           | Français           | Español            | Nummer/Bemerkung                              | ETK |
|----------|-----------|------------|------------------|-------------------|--------------------|--------------------|---|-----|
| 1        | 337 1885  | 2          | VENTILSTOESSEL   | VALVE TAPPET      | POUSSOIR           | TAQUE DE VALVULA   | 0155-11-13.01                                 |     |
| 2        | 213 3985  | 2          | STOSSSTANGE      | PUSHROD           | BARRE PARE-CHOC    | VARILLA EMPUJE     |   |     |
| 3        | 337 1881  | 4          | DICHRING         | WASHER            | BAGUE D'ETANCHEITE | ANILLO DE JUNTA    | 0155-11-10.31                                 | 01  |
| 4        | 337 1887  | 2          | KAPPE            | CAP               | CAPUCHON/CALOTTE   | SOMBRER./CAPUCHON  | 0155-11-13.05                                 |     |
| 5        | 337 1876  | 2          | SCHRAUBENFEDER   | HELICAL SPRING    | RESSORT A BOUDIN   | RESORTE HELICOIDAL | 0155-11-10.18                                 |     |
| 6        | 337 1888  | 2          | SCHUTZROHR       | COVER TUBE        | TUBE PROTECTEUR    | TUBO PROTECTOR     | 0155-11-13.12                                 |     |
| 7        | 121 6080  | 2          | SCHEIBE          | DISC/PANE/PLATE   | RONDELLE/DISQUE    | DISCO/CRISTAL/PLAT | 2 306 A 6                                     |     |
| 8        | 111 3476  | 2          | STIFTSCHRAUBE    | STUD              | GOUJON             | ESPARRAGO          | AM10 X 35 DIN 939- 8.8-A4C                    |     |
| 9        | 110 2659  | 2          | SECHSKANTMUTTER  | HEX.NUT           | ECROU 6 PANS       | TUERCA HEXAGONAL   | M10 DIN 934-M 8 A4C                           |     |
| 10       | 337 1866  | 2          | BUCHSE           | BUSH              | DOUILLE            | CASQUILLO          | 0155-11-09.09                                 |     |
| 11       | 337 1867  | 1          | KIPPHEBELBOCK    | ROCKER BRACKET    | SUPP DE CULBUTEUR  | CABALLETE BALANCIN | 0155-11-09.11                                 |     |
| 12       | 110 2800  | 2          | FEDERRING        | SPRING LOCKWASHER | RONDELLE GROWER    | ARANDELA ELASTICA  | A 10 DIN 128 A4C                              |     |
| 13       | 223 0849  | 2          | KIPPHEBEL        | ROCKER ARM        | CULBUTEUR          | BALANCIN           | VOLLST.F.EIN-U.AUSLASS<br>MIT BILD-NR.15 U.16 |     |
| 14       | 223 0852  | 2          | KIPPHEBEL        | ROCKER ARM        | CULBUTEUR          | BALANCIN           |   |     |
| 15       | 336 5861  | 2          | EINSTELLSCHRAUBE | ADJUSTING SCREW   | VIS DE REGLAGE     | TORN.GRADUACION    | 0152-11-04.08                                 | 01  |
| 16       | 111 3146  | 2          | SECHSKANTMUTTER  | HEX.NUT           | ECROU 6 PANS       | TUERCA HEXAGONAL   | M10X1 DIN 936-M55                             |     |
| 17       | 223 0850  | 2          | DELDUESE         | OIL NOZZLE        | GICLIEUR D'huile   | TOBERA ACEITE      |   |     |
| 18       | 111 2813  | 2          | SECHSKANTMUTTER  | HEX.NUT           | ECROU 6 PANS       | TUERCA HEXAGONAL   | M 6 DIN 934-M 8 A4C                           |     |
| 19       | 213 9600  | 2          | DRUCKPILZ        | THRUST PAD        | CHAMP DE POUSSEE   | SETA PRESION       |   | 01  |
| 20       | 223 0851  | 2          | BUCHSE           | BUSH              | DOUILLE            | CASQUILLO          |   |     |

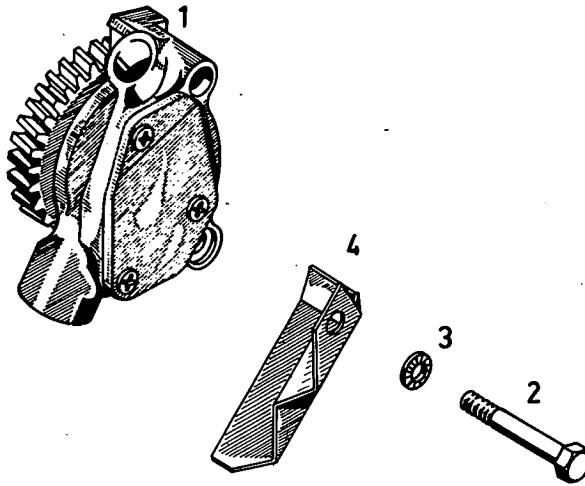

0150-14 500 4431

| Bkd Nr. | Teile-Nr. | Stück-Zahl | Deutsch           | Englisch       | Français           | Español                                      | Nummer/Bemerkung | ETK |
|---------|-----------|------------|-------------------|----------------|--------------------|--|------------------|-----|
| 1       | 213 0440  | 1          | SCHMIERÖLPUMPE    | LUBE OIL PUMP  | POMPE HUILE GRAISS | BOMBA ACEITE LUBR.                           |                  |     |
| 2       | 111 1168  | 2          | SECHSKANTSCHRAUBE | HEX.BOLT       | VIS 6 PANS         | TORNILLO HEXAGONAL M 8 X 60 DIN 931- 8.8-A4C |                  |     |
| 3       | 116 9689  | 2          | SICHERUNGSSCHEIBE | LOCKING WASHER | RONDELLE SECURITE  | ARANDELA SEGURIDAD 8 M 2203                  |                  |     |
| 4       | 213 0375  | 1          | ABSCHIRMBLECH     | SHIELD         | TOLE-ECRAN         | CHAPA PROTECTORA                             |                  |     |



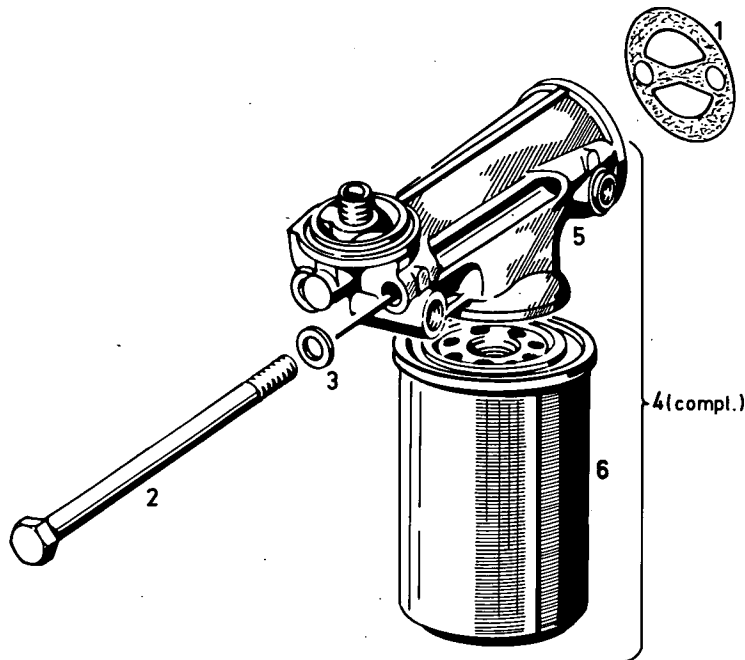

0150-15 500 4435

| Bild Nr. | Teil-Nr. | Stück-Zahl | Deutsch           | English         | Français           | Español            | Nummer/Bemerkung          | ETK |
|----------|----------|------------|-------------------|-----------------|--------------------|--------------------|---------------------------|-----|
| 1        | 336 2983 | 1          | DICHTUNG          | GASKET          | GARNITURE/JOINT    | JUNTA              | 0150-15-43.01             | 01  |
| 2        | 111 1385 | 2          | SECHSKANTSCHRAUBE | HEX.BOLT        | VIS 6 PANS         | TORNILLO HEXAGONAL | M10X 160 DIN 931- 8.8-A4C |     |
| 3        | 110 7105 | 2          | SCHEIBE           | DISC/PANE/PLATE | RONDELLE/DISQUE    | DISCO/CRISTAL/PLAT | A10,50IN 125-ST-A4C       |     |
| 4        | 210 1238 | 1          | SCHMIERÖLFILTER   | LUBE OIL FILTER | FILTRE HUILE GRAIS | FILTRO ACEITE LUBR | 0150-15-86.20             |     |
| 5        | 213 5355 | 1          | FILTERTRÄGER      | SUPPORT         | SUPPORT DE FILTRE  | PORTA-FILTRO       | 223 2097                  |     |
| 6        | 116 0024 | 1          | FILTERPATRONE     | CARTRIDGE       | CARTOUCHE FILTRANT | CARTUCHO FILTRO    | A 1 H 4123                | 01  |

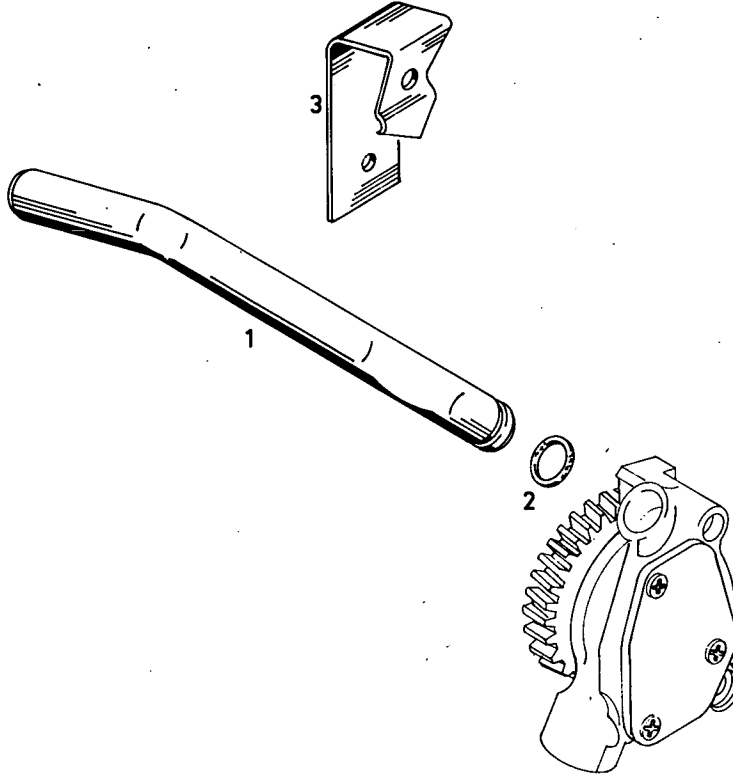

0150-16 500 3420

| Bild Nr. | Teile-Nr.           | Stück-Zahl | Deutsch     | English     | Français       | Español            | Nummer/Bemerkung | ETK      |
|----------|---------------------|------------|-------------|-------------|----------------|--------------------|------------------|----------|
| 1        | 213 6359            | 1          | ROHR        | PIPE/TUBE   | TUBE/TUYAU     | TUBO               |                  |          |
| 2        | 116 6002            | 1          | RUNDGUMRING | O-SEAL      | ANNEAU TORIQUE | ANILLO GOMA REDOND | 14 X 3 H 721-S11 |          |
| 3        | <del>346 9596</del> | 1          | BUEGELFEDER | YOKE SPRING | ETRIER-RESSORT | RESORTE ESTRIBO    | 0150-16-51.08    | 223 7494 |

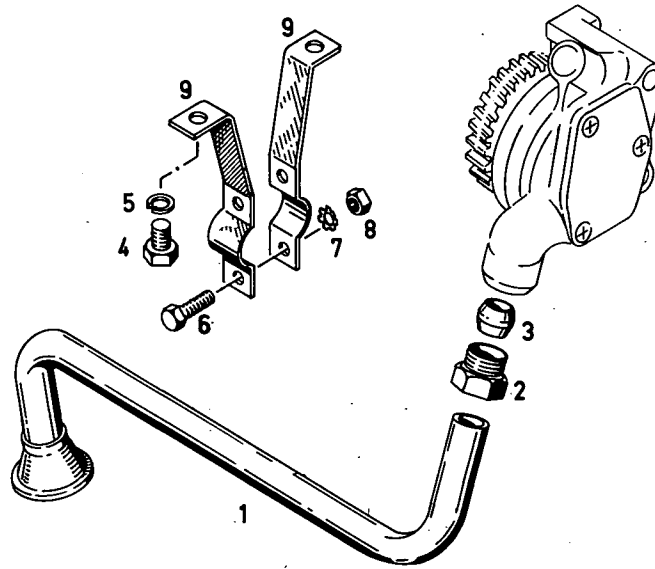
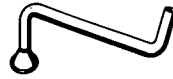

| Bild Nr. | Teile-Nr. | Stück-Zahl | Deutsch           | English           | Français           | Español            | Nummer/Bemerkung          | ETK |
|----------|-----------|------------|-------------------|-------------------|--------------------|--------------------|---------------------------|-----|
| 1        | 216 5716  | 1          | SAUGROHR          | SUCTION PIPE      | TUYAU ASPIRATION   | TUBO ASPIRACION    |                           |     |
| 2        | 121 6500  | 1          | UEBERWURFSCHRAUBE | CAP SCREW/NUT     | VIS CHAPEAU        | TORNILLO EMPALME   | 3 104 W 20                |     |
| 3        | 121 6512  | 1          | DOPPELKEILRING    | DUPLEX RING       | BAGUE CALAGE DOBLE | ANILLO CUNA DOBLE  | 3 106 W 20                | 01  |
| 4        | 111 2299  | 2          | SECHSKANTSCHRAUBE | HEX.BOLT          | VIS 6 PANS         | TORNILLO HEXAGONAL | M 8 X 12 DIN 933- 8.8-A4C |     |
| 5        | 110 2799  | 2          | FEDERRING         | SPRING LOCKWASHER | RONDILLE GROWER    | ARANDELA ELASTICA  | A 8 DIN 128 A4C           |     |
| 6        | 111 2248  | 2          | SECHSKANTSCHRAUBE | HEX.BOLT          | VIS 6 PANS         | TORNILLO HEXAGONAL | M 6 X 15 DIN 933- 8.8     |     |
| 7        | 111 7861  | 2          | ZAHNSCHEIBE       | TOOTHED WASHER    | RONDILLE DENTEE    | ARANDELA DENTADA   | A 6,4 DIN 6797            |     |
| 8        | 111 2813  | 2          | SECHSKANTMUTTER   | HEX.NUT           | ECROU 6 PANS       | TUERCA HEXAGONAL   | M 6 DIN 934-M 8 A4C       |     |
| 9        | 336 3064  | 2          | ROHRSCHELLE       | PIPE CLIP         | COLLIER PR TUBES   | ABRAZADERA DE TUBO | 0150-16-53.15             |     |



Kurzschlußleitung  
By-pass line  
Conduite de by-pass  
Tuberia by-pass

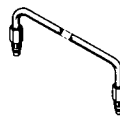

0150-16-500 6782

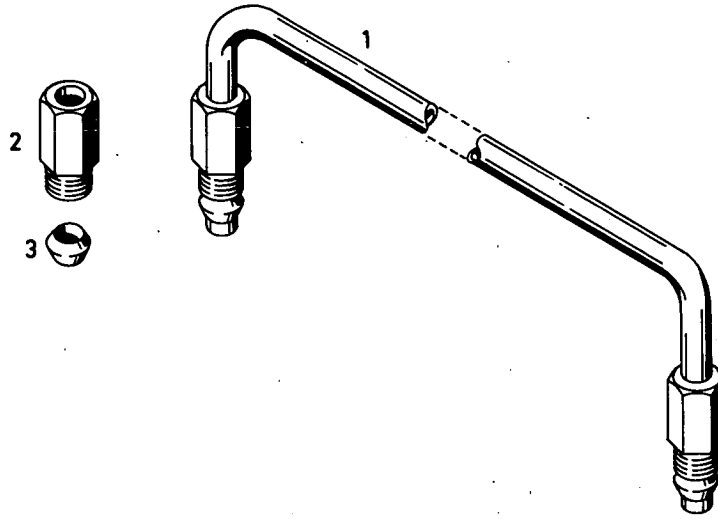

0150-16 500 6782

| Bild Nr. | Teile-Nr. | Stück-Zahl | Deutsch            | English       | Français          | Español            | Nummer/Bemerkung | ETK |
|----------|-----------|------------|--------------------|---------------|-------------------|--------------------|------------------|-----|
| 1        | 336 3070  | 1          | KURZSCHLUSSLEITUNG | BYPASS LINE   | BY-PASS           | LINEA CORTOCIRCUIT | 0150-16-60.10    |     |
| 2        | 336 3069  | 2          | HEBERWURFSCHRAUBE  | CAP SCREW/NUT | VIS CHAPEAU       | TORNILLO EMPALME   | 0150-16-60.02    |     |
| 3        | 121 6511  | 2          | DOPPELKEILRING     | DUPLEX RING   | BAGUE CALAGE DBLE | ANILLO CUNA DOBLE  | 3 106 W 18       |     |

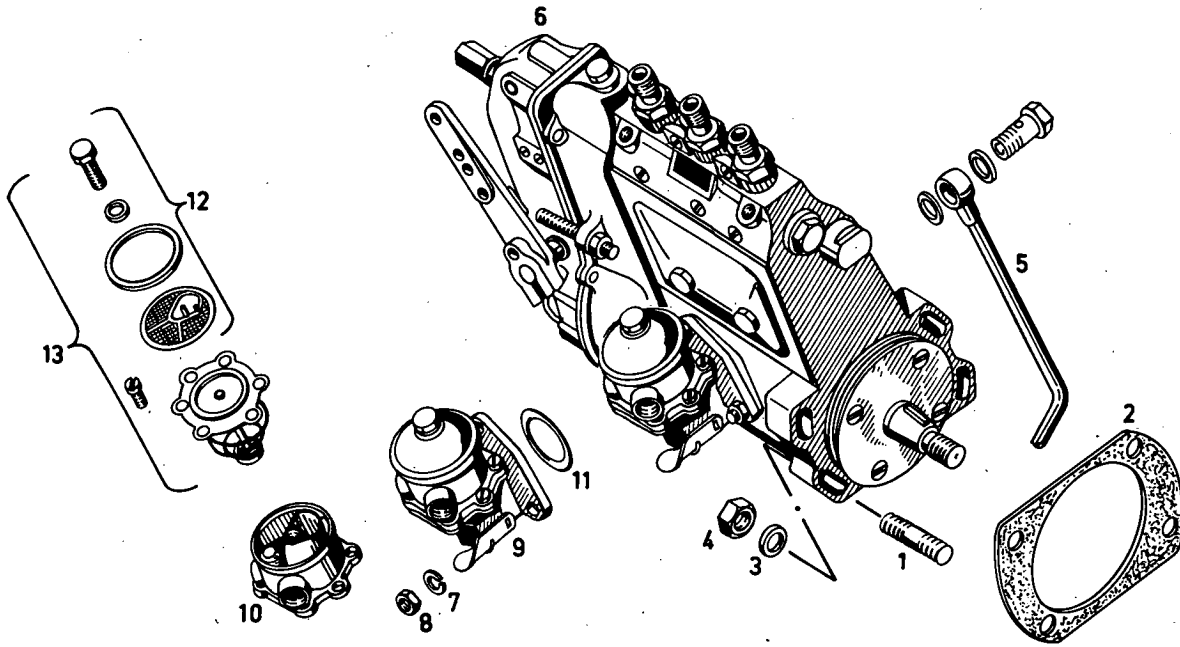
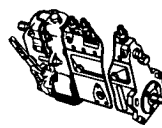

0150-17 500 1667

| Bild Nr. | Teile-Nr. | Stück-Zahl | Deutsch           | English           | Français          | Español            | Nummer/Bemerkung          | ETK |
|----------|-----------|------------|-------------------|-------------------|-------------------|--------------------|---------------------------|-----|
| 1        | 110 2301  | 4          | STIFTSCHRAUBE     | STUD              | GOUJON            | ESPARRAGO          | M10 X 30 DIN 939- 6.8-A4C |     |
| 2        | 213 6717  | 1          | DICHTUNG          | GASKET            | GARNITURE/JOINT   | JUNTA              |                           | 01  |
| 3        | 110 7105  | 4          | SCHEIBE           | DISC/PANE/PLATE   | RONDELLE/DISQUE   | DISCO/CRISTAL/PLAT | A10,5DIN 125-ST-A4C       |     |
| 4        | 110 2659  | 4          | SECHSKANTMUTTER   | HEX.NUT           | ECROU 6 PANS      | TUERCA HEXAGONAL   | M10 DIN 934-M 8 A4C       |     |
| 5        | 336 3161  | 1          | UEBERSTROMLEITUNG | OVERFLOW LINE     | CONDUITE DECHARGE | TUBERIA REBOSAMTO. | 0150-17-12.10             |     |
| 6        | 291 2696  | 1          | EINSPRITZPUMPE    | INJECTION PUMP    | POMPE D'INJECTION | BOMBA INYECCION    |                           |     |
| 7        | 110 2797  | 3          | FEDERRING         | SPRING LOCKWASHER | RONDELLE GROWER   | ARANDELA ELASTICA  | A 6 DIN 128 A4C           |     |
| 8        | 111 2813  | 3          | SECHSKANTMUTTER   | HEX.NUT           | ECROU 6 PANS      | TUERCA HEXAGONAL   | M 6 DIN 934-M 8 A4C       |     |
| 9        | 213 4511  | 1          | KRAFTSTOFFPUMPE   | FUEL PUMP         | POMPE A COMBUST   | BOMBA COMBUSTIBLE  |                           |     |
| 10       | 210 2660  | 1          | PUMPENOBERTEIL    | PUMP TOP          | PARTIE SUP POMPE  | PRTE.SUPR.BOMBA    | 0150-17-20.02             |     |
| 11       | 116 2625  | 1          | RUNDGUMMRING      | O-SEAL            | ANNEAU TORIQUE    | ANILLO GOMA REDOND | 35 X 2,5 H 2927-SGB       |     |
| 12       | 126 0049  | 1          | REPARATURSATZ     | REPAIR KIT        | LOT DE REPARATION | LOTE REPARACIONES  |                           | 01  |
| 13       | 213 0225  | 1          | REPARATURSATZ     | REPAIR KIT        | LOT DE REPARATION | LOTE REPARACIONES  |                           | 01  |



Überströmventil  
 Overflow valve  
 Valve de décharge  
 Válvula de rebosamiento

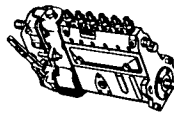

0150-17-500 3451

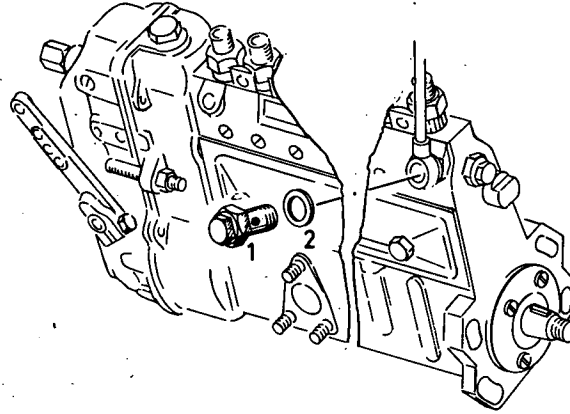

0150-17 500 3451

| Bild Nr. | Teile-Nr. | Stück-Zahl | Deutsch         | English        | Français           | Español           | Nummer / Bemerkung    | ETK |
|----------|-----------|------------|-----------------|----------------|--------------------|-------------------|-----------------------|-----|
| 1        | 213 5002  | 1          | ÜBERSTROMVENTIL | OVERFLOW VALVE | SOUPAPE DECHARGE   | VALV.REBOSAMIENTO |                       |     |
| 2        | 111 8688  | 2          | DICHTRING       | WASHER         | BAGUE D'ETANCHEITE | ANILLO DE JUNTA   | A 14 X 18 DIN 7603-CU |     |

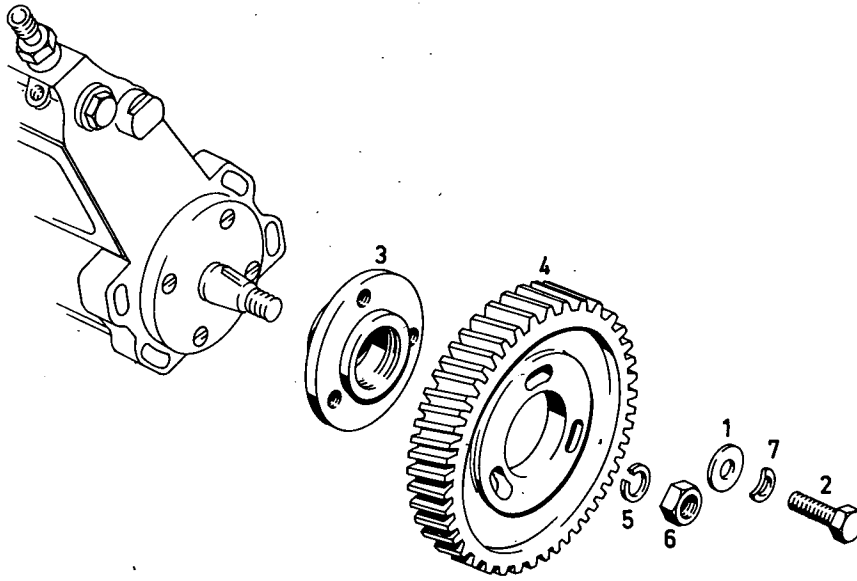

0150-18 500 5869

| Bild Nr. | Teile-Nr. | Stück-Zahl | Deutsch           | English           | Français        | Español            | Nummer / Bemerkung          | ETK |
|----------|-----------|------------|-------------------|-------------------|-----------------|--------------------|-----------------------------|-----|
| 1        | 121 1206  | 3          | SCHEIBE           | DISC/PANE/PLATE   | RONDELLE/DISQUE | DISCO/CRISTAL/PLAT | 2 308 A 51                  |     |
| 2        | 112 8196  | 3          | SECHSKANTSCHRAUBE | HEX.BOLT          | VIS 6 PANS      | TORNILLO HEXAGONAL | M 8X1 X 25 DIN 961- 8.8-A4C |     |
| 3        | 213 9284  | 1          | NABE              | HUB               | MOYEU           | CUBO               |                             |     |
| 4        | 213 9287  | 1          | ZAHNRAD           | GEAR              | ROUE DENTEE     | RUEDA DENTADA      |                             |     |
| 5        | 110 2801  | 1          | FEDERRING         | SPRING LOCKWASHER | RONDELLE GROWER | ARANDELA ELASTICA  | A 12 DIN 128 A4C            |     |
| 6        | 111 2861  | 1          | SECHSKANTMUTTER   | HEX.NUT           | ECROU 6 PANS    | TUERCA HEXAGONAL   | M12 DIN 934-M10             |     |
| 7        | 110 7281  | 3          | FEDERRING         | SPRING LOCKWASHER | RONDELLE GROWER | ARANDELA ELASTICA  | 8 8 DIN 137                 |     |



Einspritzventil  
Injector  
Injecteur  
Inyector

Stück / Zyl.-Einheit  
Pieces / cyl. unit  
Qté / cylindre  
Cantid./unid. cilind.



0150-19-500 3849

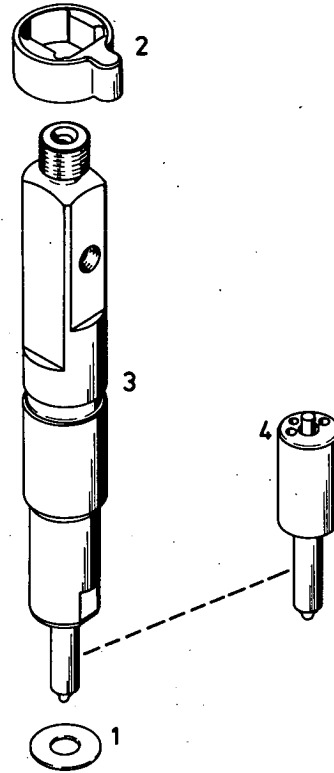

0150-19 500 3849

| Bild Nr. | Teile-Nr. | Stück-Zahl | Deutsch         | English  | Français           | Español         | Nummer/Bemerkung | ETK |
|----------|-----------|------------|-----------------|----------|--------------------|-----------------|------------------|-----|
| 1        | 337 2164  | 1          | DICHRING        | WASHER   | BAGUE D'ETANCHEITE | ANILLO DE JUNTA | 0155-19-08.06    | 01  |
| 2        | 213 7568  | 1          | BUCHSE          | BUSH     | DOUILLE            | CASQUILLO       |                  |     |
| 3        | 213 7912  | 1          | EINSPRITZVENTIL | INJECTOR | SOUPAPE D'INJECT   | INYECTOR        |                  |     |
| 4        | 210 1221  | 1          | DUESE           | NOZZLE   | INJECTEUR/GICLÉUR  | TOBERA          | 0155-19-10.03    | 01  |



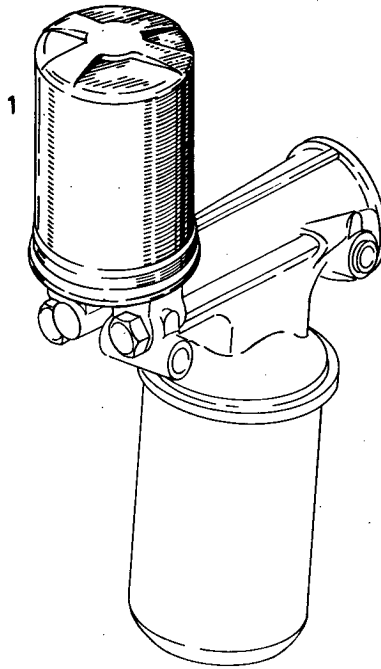

0150-20 500 3462

| Bild Nr. | Teil-Nr. | Stück-Zahl | Deutsch          | English     | Français         | Español            | Nummer/Bemerkung | ETK |
|----------|----------|------------|------------------|-------------|------------------|--------------------|------------------|-----|
| 1        | 116 0243 | 1          | KRAFTSTOFFFILTER | FUEL FILTER | FILTRE A COMBUST | FILTRD COMBUSTIBLE | Q 1 H 4117       | 01  |

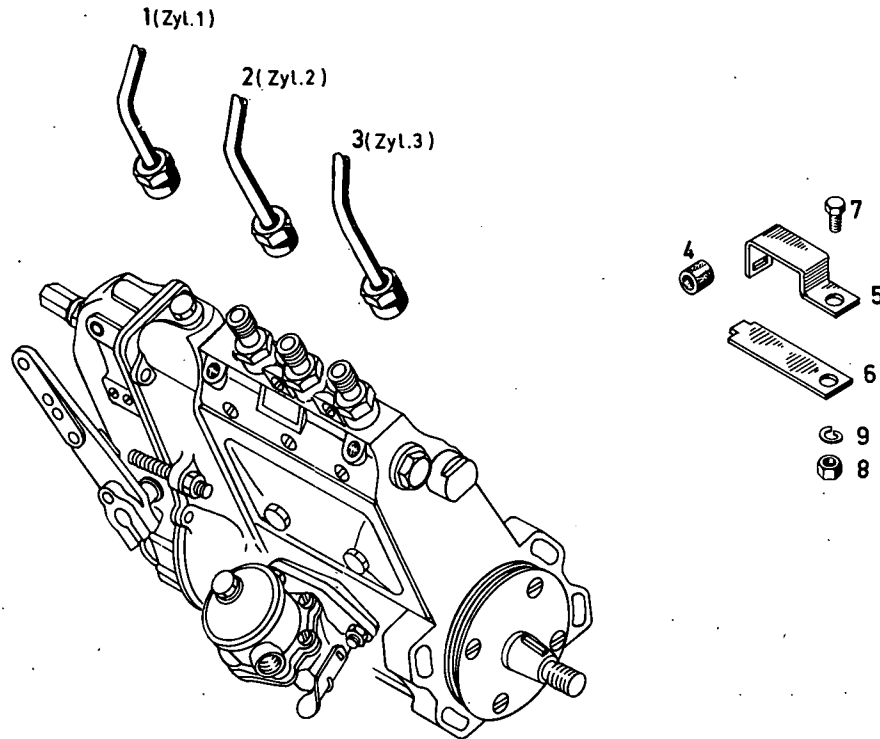
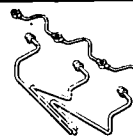

0150-21 500 6749

| Bild Nr. | Teile-Nr. | Stück-Zahl | Deutsch           | English           | Français           | Español            | Nummer/Bemerkung         | ETK |
|----------|-----------|------------|-------------------|-------------------|--------------------|--------------------|--------------------------|-----|
| 1        | 213 7916  | 1          | EINSPRITZLEITUNG  | INJECTION LINE    | CONDUITE D'INJECT  | TUBERIA INYECC.    | ZUM ZYL. 1               |     |
| 2        | 213 7917  | 1          | EINSPRITZLEITUNG  | INJECTION LINE    | CONDUITE D'INJECT  | TUBERIA INYECC.    | ZUM ZYL. 2               |     |
| 3        | 213 7918  | 1          | EINSPRITZLEITUNG  | INJECTION LINE    | CONDUITE D'INJECT  | TUBERIA INYECC.    | ZUM ZYL. 3               |     |
| 4        | 337 2269  | 2          | GUMMIUFFE         | RUBBER SLEEVE     | MANCHON CAOUTCHOUC | MANGUITO CAUCHO    | 0155-21-73.05            |     |
| 5        | 116 1469  | 1          | ROHRSCHELLE       | PIPE CLIP         | COLLIER PR TUBES   | ABRAZADERA DE TUBO | B 2X 6H 3220             |     |
| 6        | 117 0642  | 1          | SCHLUSSPLATTE     | END PLATE         | PLAQUE EXTREME     | PLACA FINAL        | C 2X 6H 3220             |     |
| 7        | 111 2240  | 1          | SECHSKANTSCHRAUBE | HEX.BOLT          | VIS 6 PANS         | TORNILLO HEXAGONAL | M 6X 12 DIN 933- 8.8-A4C |     |
| 8        | 111 2813  | 1          | SECHSKANTMUTTER   | HEX.NUT           | ECROU 6 PANS       | TUERCA HEXAGONAL   | M 6 DIN 934-M 8 A4C      |     |
| 9        | 110 2797  | 1          | FEDERRING         | SPRING LOCKWASHER | RONDELLE GROVER    | ARANDELA ELASTICA  | A 6 DIN 128 A4C          |     |

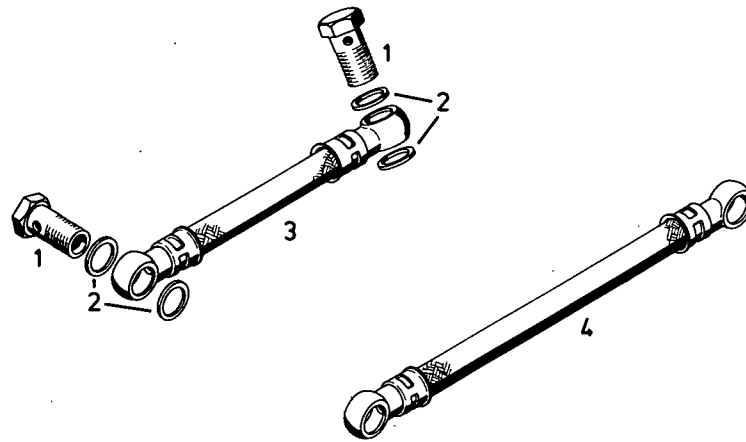
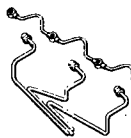

0150-21 500 6858

| Bild Nr. | Teile-Nr. | Stück-Zahl | Deutsch         | English    | Français           | Español         | Nummer/Bemerkung      | ETK |
|----------|-----------|------------|-----------------|------------|--------------------|-----------------|-----------------------|-----|
| 1        | 111 9246  | 4          | HOHLSCHRAUBE    | BANJO BOLT | VIS BANJO          | TORNILLO RACOR  | A 8 DIN 7623 VZKC     |     |
| 2        | 111 8688  | 8          | DICHRING        | WASHER     | BAGUE D'ETANCHEITE | ANILLO DE JUNTA | A 14 X 18 DIN 7603-CU |     |
| 3        | 124 3184  | 1          | SCHLAUCHLEITUNG | HOSE       | CONDUITE FLEXIBLE  | MANGUERA        |                       | 01  |
| 4        | 126 6159  | 1          | SCHLAUCHLEITUNG | HOSE       | CONDUITE FLEXIBLE  | MANGUERA        | 8734-80-03.150        | 01  |



Überströmleitung  
 Overflow pipe  
 Conduit de décharge  
 Tubería de rebosamiento



0150-21-500 4680

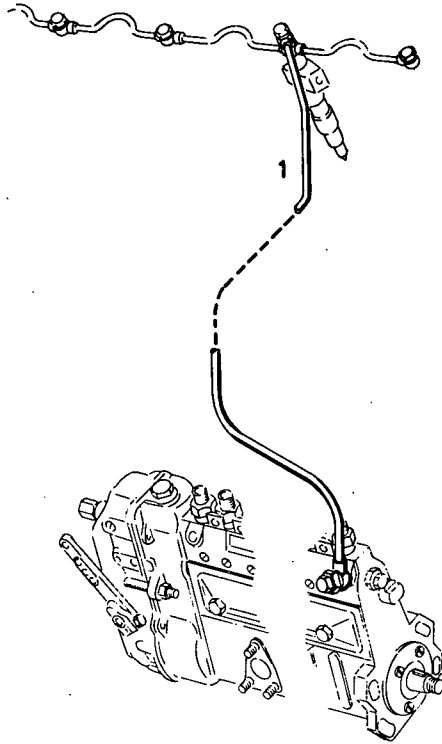

0150-21 500 4680

| Bld<br>Nr. | Teile-Nr. | Stück-<br>Zahl | Deutsch          | English       | Français          | Español            | Nummer/Bemerkung | ETK |
|------------|-----------|----------------|------------------|---------------|-------------------|--------------------|------------------|-----|
| 1          | 213 7519  | 1              | ÜBERSTROMLEITUNG | OVERFLOW LINE | CONDUITE DECHARGE | TUBERIA REBOSAMTO. |                  |     |

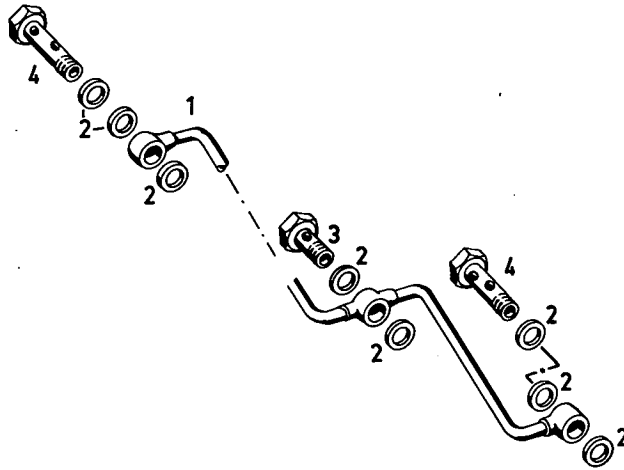
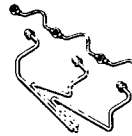

0150-21 500 6861

| Bild Nr. | Teile-Nr. | Stück-Zahl | Deutsch        | English          | Français           | Español            | Nummer/Bemerkung      | ETK |
|----------|-----------|------------|----------------|------------------|--------------------|--------------------|-----------------------|-----|
| 1        | 213 7996  | 1          | LECKDELLEITUNG | BACKLEAKAGE LINE | COND HUILE DE FUIT | TUBER.COMBUST.SOBR |                       |     |
| 2        | 111 8647  | 8          | DICHTRING      | WASHER           | BAGUE D'ÉTANCHEITE | ANILLO DE JUNTA    | A 8 X 11,5DIN 7603-CU | 01  |
| 3        | 111 9231  | 1          | HOHLSCHRAUBE   | BANJO BOLT       | VIS BANJO          | TORNILLO RACOR     | A 2-30IN 7623 VZKC    |     |
| 4        | 121 6492  | 2          | HOHLSCHRAUBE   | BANJO BOLT       | VIS BANJO          | TORNILLO RACOR     | 3 103 F 5             |     |

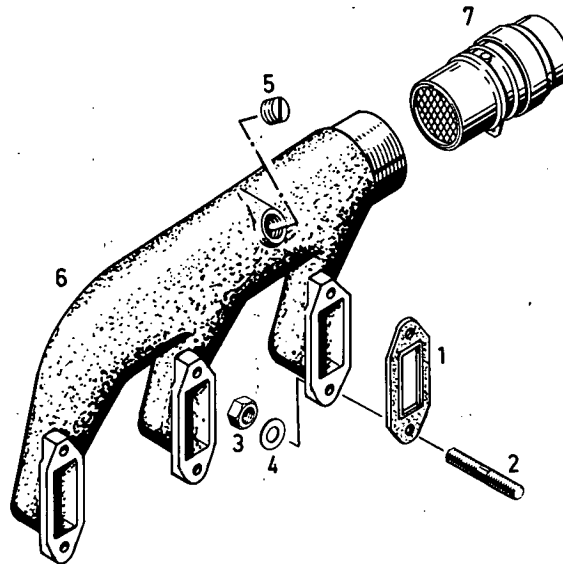

0150-22 500 6836

| Bild Nr. | Teil-Nr. | Stück-Zahl | Deutsch         | English            | Français           | Español            | Nummer/Bemerkung         | ETK |
|----------|----------|------------|-----------------|--------------------|--------------------|--------------------|--------------------------|-----|
| 1        | 337 1689 | 3          | DICHTUNG        | GASKET             | GARNITURE/JOINT    | JUNTA              | 0155-08-20.99            | 01  |
| 2        | 111 0190 | 6          | STIFTSCHRAUBE   | STUD               | GOUJON             | ESPARRAGO          | M 8X 35 SM4 DIN 835- 8.8 |     |
| 3        | 111 2824 | 6          | SECHSKANTMUTTER | HEX.NUT            | ECROU 6 PANS       | TUERCA HEXAGONAL   | M 8 DIN 934-M 8 A4C      |     |
| 4        | 110 7101 | 6          | SCHEIBE         | DISC/PANE/PLATE    | RONDELLE/DISQUE    | DISCO/CRISTAL/PLAT | A 8,40IN 125-ST-A4C      |     |
| 5        | 116 5789 | 1          | SCHLITZSTOPFEN  | SLOTTED PLUG       | BOUCHON FENDU      | TAPON RAMURADO     | M20X1,5 H 710            |     |
| 6        | 213 5532 | 1          | LUFTANSAUGROHR  | INTAKE PIPE/MANIF. | TUBE D'ASPIR D'AIR | TUBO ASPIRAC.AIRE  |                          |     |
| 7        | 116 1412 | 1          | HEIZROHR        | HEATING TUBE       | TUBE CHAUFFANT     | TUBO CALEFACCION   | H 10,5 H 7628            |     |

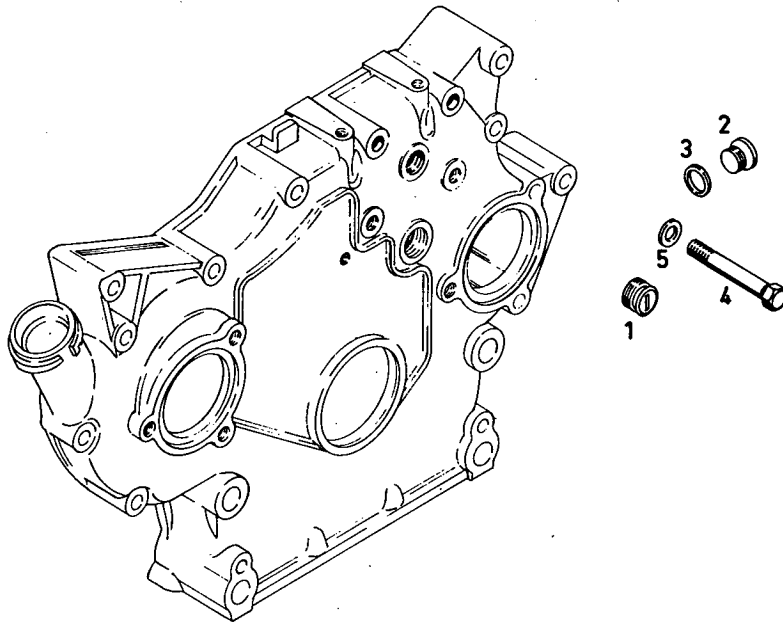

0150-33 500 3549

| Bild Nr. | Teil-Nr. | Stück-Zahl | Deutsch            | English         | Français           | Español            | Nummer/Bemerkung          | ETK |
|----------|----------|------------|--------------------|-----------------|--------------------|--------------------|---------------------------|-----|
| 1        | 116 5788 | 1          | SCHLITZSTOPFEN     | SLOTTED PLUG    | BOUCHON FENDU      | TAPON RANURADO     | M18X1,5 H 710             |     |
| 2        | 111 0422 | 1          | VERSCHLUSSSCHRAUBE | SCREW PLUG      | BOUCHON FILETE     | TAPON ROSCADO      | M12X1,5 DIN 908           |     |
| 3        | 111 8673 | 1          | DICHTRING          | WASHER          | BAGUE D'ETANCHEITE | ANILLO DE JUNTA    | A 12 X 15,5 DIN 7603-CU   |     |
| 4        | 111 1179 | 2          | SECHSKANTSCHRAUBE  | HEX. BOLT       | VIS 6 PANS         | TORNILLO HEXAGONAL | M 8 X 70 DIN 931- 8.8-A4C |     |
| 5        | 110 7101 | 2          | SCHEIBE            | DISC/PANE/PLATE | RONDELLE/DISQUE    | DISCO/CRISTAL/PLAT | A 8,4 DIN 125-ST-A4C      |     |

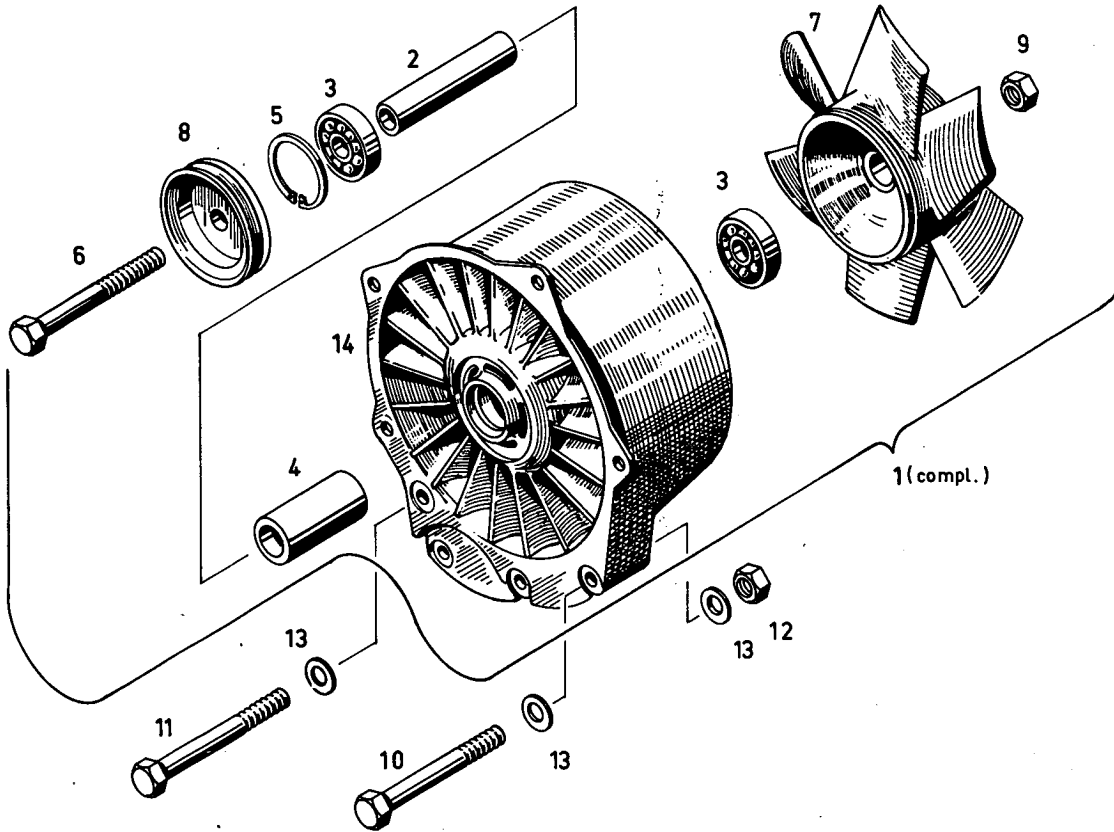

0150-39 500 4526

| Bld Nr. | Teile-Nr. | Stück-Zahl | Deutsch            | English         | Français            | Español            | Nummer/Bemerkung           | ETK |
|---------|-----------|------------|--------------------|-----------------|---------------------|--------------------|----------------------------|-----|
| 1       | 213 9852  | 1          | KUEHLGEBLAESE      | COOLING BLOWER  | SOUFFLANTE REFRROID | VENTILADOR REFRIG  |                            |     |
| 2       | 336 3658  | 1          | HOHLWELLE          | QUILL SHAFT     | ARBRE CREUX         | EJE HUECO          | 0150-39-05.03              |     |
| 3       | 110 9041  | 2          | RILLENKUGELLAGER   | BALL BEARING    | ROUL RAINURE BILLE  | COJ.BOLAS FIJO     | 6204 Z C3DIN 625           | 01  |
| 4       | 213 3633  | 1          | BUCHSE             | BUSH            | DOUILLE             | CASQUILLO          |                            |     |
| 5       | 110 7834  | 1          | SICHERUNGSRING     | CIRCLIP         | CIRCLIP             | CIRCLIP            | 47X1.75DIN 472             | 01  |
| 6       | 111 1589  | 1          | SECHSKANTSCHRAUBE  | HEX.BOLT        | VIS 6 PANS          | TORNILLO HEXAGONAL | M12X 140 DIN 931-M 8.8-A4C | 01  |
| 7       | 213 5902  | 1          | LAUFRAD            | BOTTOM ROLLER   | ROUE A AUBES/ROTOR  | ROTOR/RODILL.RODAD |                            |     |
| 8       | 213 3636  | 1          | KEILRIEMENSCHLEIBE | V-BELT PULLE    | POULTE COURR TRAP   | POLEA ACANALADA    |                            |     |
| 9       | 111 2858  | 1          | SECHSKANTMUTTER    | HEX.NUT         | ECROU 6 PANS        | TUERCA HEXAGONAL   | M12 DIN 934-M 8 A4C        |     |
| 10      | 111 1210  | 3          | SECHSKANTSCHRAUBE  | HEX.BOLT        | VIS 6 PANS          | TORNILLO HEXAGONAL | M 8X 105 DIN 931- 8.8-A4C  |     |
| 11      | 112 6979  | 1          | SECHSKANTSCHRAUBE  | HEX.BOLT        | VIS 6 PANS          | TORNILLO HEXAGONAL | M 8X 95 DIN 931- 8.8-A4C   |     |
| 12      | 111 2824  | 1          | SECHSKANTMUTTER    | HEX.NUT         | ECROU 6 PANS        | TUERCA HEXAGONAL   | M 8 DIN 934-M 8 A4C        |     |
| 13      | 110 7101  | 5          | SCHEIBE            | DISC/PANE/PLATE | RONDELLE/DISQUE     | DISCO/CRISTAL/PLAT | A 8,4DIN 125-ST-A4C        |     |
| 14      | 213 9851  | 1          | GEBLAESE           | BLOWER          | SOUFFLANTE          | SOPLANTE/VENTILAD. |                            |     |



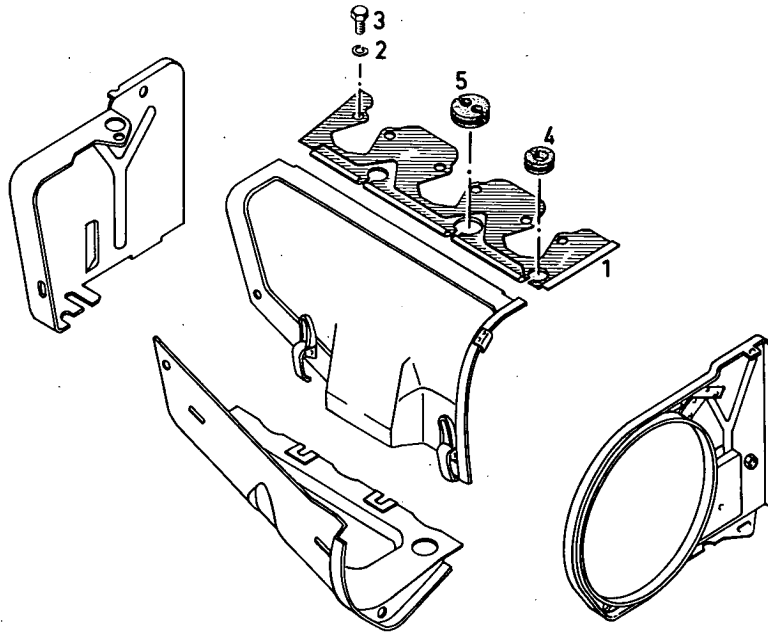

0150-40 500 6773

| Bild Nr. | Teil-Nr. | Stück-Zahl | Deutsch           | English           | Français         | Español            | Nummer/Bemerkung         | ETK |
|----------|----------|------------|-------------------|-------------------|------------------|--------------------|--------------------------|-----|
| 1        | 213 7358 | 1          | FUEHRUNGSLEISTE   | GUIDE RAIL        | BARRE CONDUCTR   | LISTON GUIA        |                          |     |
| 2        | 110 2797 | 6          | FEDERRING         | SPRING LOCKWASHER | RONDELLE GROMER  | ARANDELA ELASTICA  | A 6 DIN 128 A4C          |     |
| 3        | 111 2251 | 6          | SECHSKANTSCHRAUBE | HEX.BOLT          | VIS 6 PANS       | TORNILLO HEXAGONAL | M 6X 15 DIN 933- 8.8-A4C |     |
| 4        | 116 0592 | 2          | GUMMITUELLE       | RUBBER GROMMET    | GAINE CADUTCHOUC | FUNDA CAUCHO       | F 6,5X21 X 1,5 H 2928    |     |
| 5        | 336 1809 | 1          | GUMMITUELLE       | RUBBER GROMMET    | GAINE CADUTCHOUC | FUNDA CAUCHO       | 0146-21-03.05            |     |

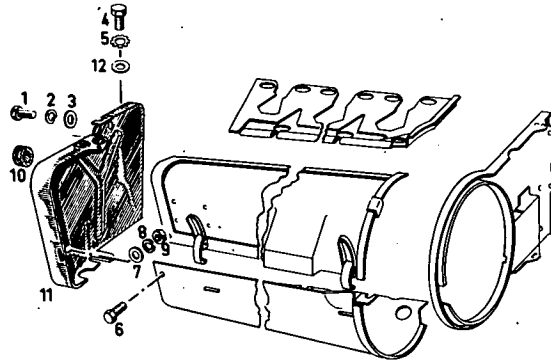
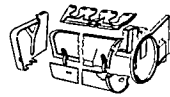

0150-40 500 3578

| Bild Nr. | Teile-Nr. | Stück-Zahl | Deutsch           | English           | Français           | Español            | Nummer/Bemerkung         | ETK |
|----------|-----------|------------|-------------------|-------------------|--------------------|--------------------|--------------------------|-----|
| 1        | 111 2240  | 1          | SECHSKANTSCHRAUBE | HEX. BOLT         | VIS 6 PANS         | TORNILLO HEXAGONAL | M 6X 12 DIN 933- 8.8-A4C |     |
| 2        | 110 2797  | 1          | FEDERRING         | SPRING LOCKWASHER | RONDELLE GROWER    | ARANDELA ELASTICA  | A 6 DIN 128 A4C          |     |
| 3        | 121 5850  | 1          | SCHEIBE           | DISC/PANE/PLATE   | RONDELLE/DISQUE    | DISCO/CRISTAL/PLAT | 1 144 D                  |     |
| 4        | 111 2299  | 1          | SECHSKANTSCHRAUBE | HEX. BOLT         | VIS 6 PANS         | TORNILLO HEXAGONAL | M 8X 12 DIN 933- 8.8-A4C |     |
| 5        | 110 7283  | 1          | FEDERSCHEIBE      | SPRING WASHER     | RONDELLE ELASTIQUE | ARANDELA ELASTICA  | B 8 DIN 137 VZKC         |     |
| 6        | 111 2240  | 1          | SECHSKANTSCHRAUBE | HEX. BOLT         | VIS 6 PANS         | TORNILLO HEXAGONAL | M 6X 12 DIN 933- 8.8-A4C |     |
| 7        | 110 7095  | 1          | SCHEIBE           | DISC/PANE/PLATE   | RONDELLE/DISQUE    | DISCO/CRISTAL/PLAT | A 8,4DIN 125-ST-A4C      |     |
| 8        | 110 2797  | 1          | FEDERRING         | SPRING LOCKWASHER | RONDELLE GROWER    | ARANDELA ELASTICA  | A 6 DIN 128 A4C          |     |
| 9        | 111 2813  | 1          | SECHSKANTMUTTER   | HEX. NUT          | ECROU 6 PANS       | TUERCA HEXAGONAL   | M 6 DIN 934-M 8 A4C      |     |
| 10       | 116 7425  | 1          | GUMMITUELLE       | RUBBER GROMMET    | GAINE CADUTCHOUC   | FUNDA CAUCHO       | D13,5X17 X 1,5 M 2928    |     |
| 11       | 210 1805  | 1          | BLECH             | PLATE             | TOLE               | CHAPA              | 0150-40-103.17           |     |
| 12       | 110 7101  | 1          | SCHEIBE           | DISC/PANE/PLATE   | RONDELLE/DISQUE    | DISCO/CRISTAL/PLAT | A 8,4DIN 125-ST-A4C      |     |

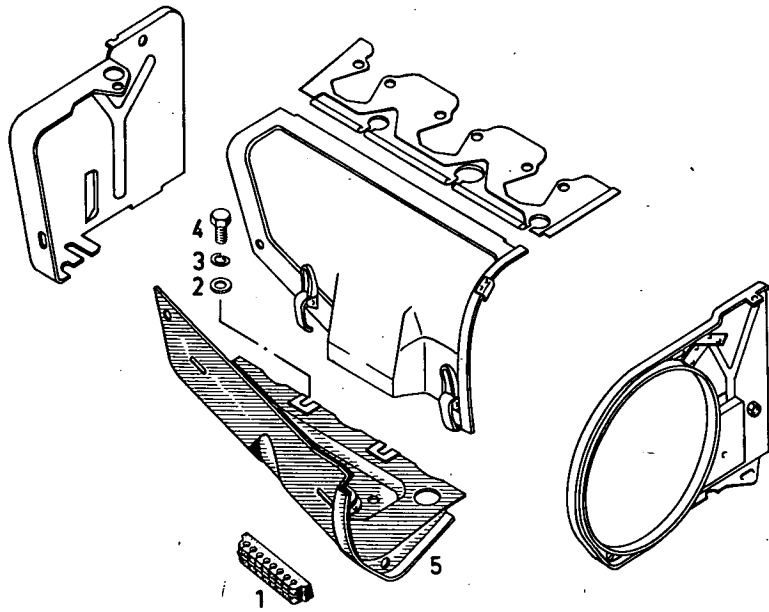
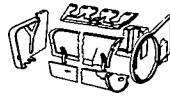

0150-40 500 6777

| Bild Nr. | Teil-Nr. | Stück-Zahl | Deutsch           | English           | Français         | Español            | Nummer/Bemerkung          | ETK |
|----------|----------|------------|-------------------|-------------------|------------------|--------------------|---------------------------|-----|
| 1        | 210 1802 | 1          | GUMMI             | RUBBER            | CAOUTCHOUC       | GORRA/CAUCHO       | 0150-40-103.51            |     |
| 2        | 110 7101 | 3          | SCHEIBE           | DISC/PANE/PLATE   | RONDELLE/DISQUE  | DISCO/CRISTAL/PLAT | A 8,4DIN 125-ST-A4C       |     |
| 3        | 110 2799 | 3          | FEDERING          | SPRING LOCKWASHER | RONDELLE GROVER  | ARANDELA ELASTICA  | A 8 DIN 120 A4C           |     |
| 4        | 111 2299 | 3          | SECHSKANTSCHRAUBE | HEX.BOLT          | VIS 6 PANS       | TORNILLO HEXAGONAL | M. 8X 12 DIN 933- 8,8-A4C |     |
| 5        | 210 1700 | 1          | LUFTFUEHRUNGSTEIL | DUCT PART         | PARTIE GUIDE-AIR | PZA.GUIA AIRE      |                           |     |

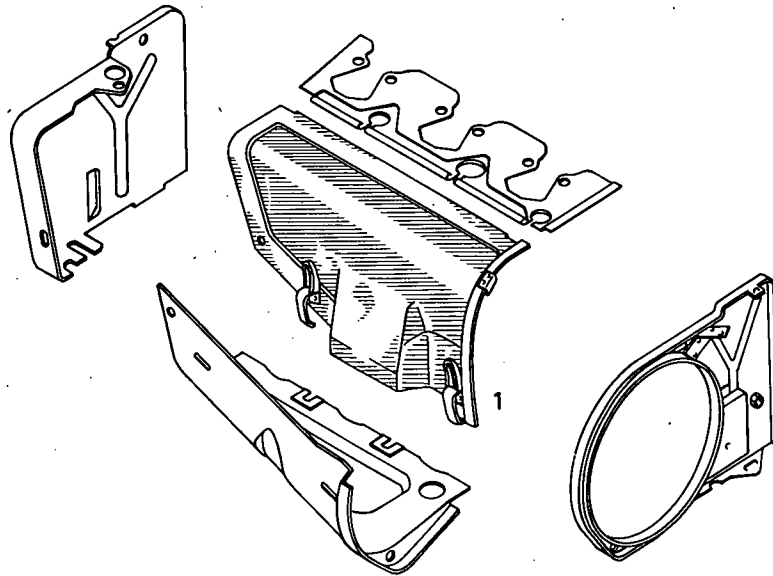
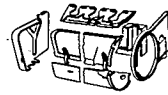

0150-40 500 6780

| Bild-Nr. | Teile-Nr. | Stück-Zahl | Deutsch          | English   | Français         | Español       | Nummer/Bemerkung | ETK |
|----------|-----------|------------|------------------|-----------|------------------|---------------|------------------|-----|
| 1        | 210 1702  | 1          | LUFTFUHRUNGSTEIL | DUCT PART | PARTIE GUIDE-AIR | PZA.GUIA AIRE | 0150-40-120.10   |     |

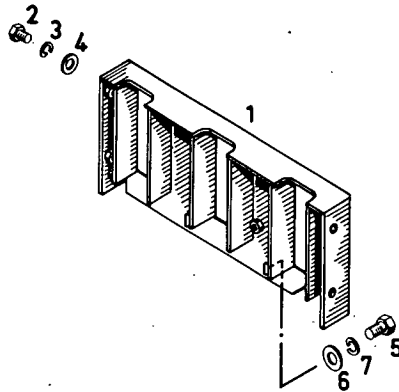
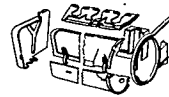

0150-40 500 6839

| Bild Nr. | Teile-Nr. | Stück-Zahl | Deutsch           | English           | Français         | Español            | Nummer/Bemerkung         | ETK |
|----------|-----------|------------|-------------------|-------------------|------------------|--------------------|--------------------------|-----|
| 1        | 210 2217  | 1          | ABSCHIRMBLECH     | SHIELD            | TÔLE-ECRAN       | CHAPA PROTECTORA   | 0150-40-121.10           |     |
| 2        | 111 2232  | 4          | SECHSKANTSCHRAUBE | HEX. BOLT         | VIS 6 PANS       | TORNILLO HEXAGONAL | M 6X 10 DIN 933- 8.8-A4C |     |
| 3        | 110 2797  | 4          | FEDERRING         | SPRING LOCKWASHER | RONDELLE GROUVER | ARANDELA ELASTICA  | A 6 DIN 128 A4C          |     |
| 4        | 121 5850  | 4          | SCHEIBE           | DISC/PANE/PLATE   | RONDELLE/DISQUE  | DISCO/CRISTAL/PLAT | 1 144 D                  |     |
| 5        | 111 2305  | 2          | SECHSKANTSCHRAUBE | HEX. BOLT         | VIS 6 PANS       | TORNILLO HEXAGONAL | M 8X 15 DIN 933- 8.8-A4C |     |
| 6        | 110 7101  | 2          | SCHEIBE           | DISC/PANE/PLATE   | RONDELLE/DISQUE  | DISCO/CRISTAL/PLAT | A 8,4DIN 125-ST-A4C      |     |
| 7        | 110 2799  | 2          | FEDERRING         | SPRING LOCKWASHER | RONDELLE GROUVER | ARANDELA ELASTICA  | A 8 DIN 128 A4C          |     |

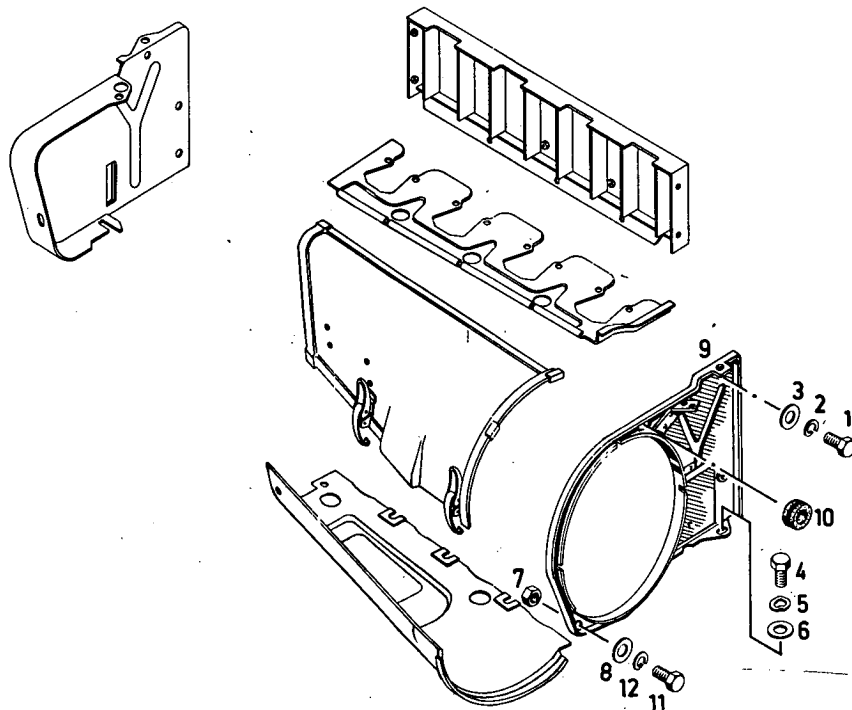

0150-40 500 4653

| Bild Nr. | Teile-Nr. | Stück-Zahl | Deutsch           | English           | Français           | Español            | Nummer/Bemerkung         | ETK |
|----------|-----------|------------|-------------------|-------------------|--------------------|--------------------|--------------------------|-----|
| 1        | 111 2240  | 1          | SECHSKANTSCHRAUBE | HEX.BOLT          | VIS 6 PANS         | TORNILLO HEXAGONAL | M 6X 12 DIN 933- 8.8-A4C |     |
| 2        | 110 2797  | 1          | FEDERRING         | SPRING LOCKWASHER | RONDELLE GROVER    | ARANDELA ELASTICA  | A 6 DIN 128 A4C          |     |
| 3        | 121 5850  | 1          | SCHEIBE           | DISC/PANE/PLATE   | RONDELLE/DISQUE    | DISCO/CRISTAL/PLAT | 1 144 D                  |     |
| 4        | 111 2299  | 1          | SECHSKANTSCHRAUBE | HEX.BOLT          | VIS 6 PANS         | TORNILLO HEXAGONAL | M 8X 12 DIN 933- 8.8-A4C |     |
| 5        | 110 7283  | 1          | FEDERSCHEIBE      | SPRING WASHER     | RONDELLE ELASTIQUE | ARANDELA ELASTICA  | 8 8 DIN 137 VZKC         |     |
| 6        | 110 7101  | 1          | SCHEIBE           | DISC/PANE/PLATE   | RONDELLE/DISQUE    | DISCO/CRISTAL/PLAT | A 8,4DIN 125-ST-A4C      |     |
| 7        | 111 2813  | 1          | SECHSKANTMUTTER   | HEX.NUT           | ECROU 6 PANS       | TUERCA HEXAGONAL   | M 6 DIN 934-M 8 A4C      |     |
| 8        | 110 7095  | 1          | SCHEIBE           | DISC/PANE/PLATE   | RONDELLE/DISQUE    | DISCO/CRISTAL/PLAT | A 6,4DIN 125-ST-A4C      |     |
| 9        | 210 1698  | 1          | BLECH             | PLATE             | TOLE               | CHAPA              |                          |     |
| 10       | 116 7425  | 1          | GUMMITUELLE       | RUBBER GROMMET    | GAINE CADUTCHOUC   | FUNDA CAUCHO       | D13,5X17 X 1,5 H 2928    |     |
| 11       | 111 2240  | 1          | SECHSKANTSCHRAUBE | HEX.BOLT          | VIS 6 PANS         | TORNILLO HEXAGONAL | M 6X 12 DIN 933- 8.8-A4C |     |
| 12       | 110 2797  | 1          | FEDERRING         | SPRING LOCKWASHER | RONDELLE GROVER    | ARANDELA ELASTICA  | A 6 DIN 128 A4C          |     |

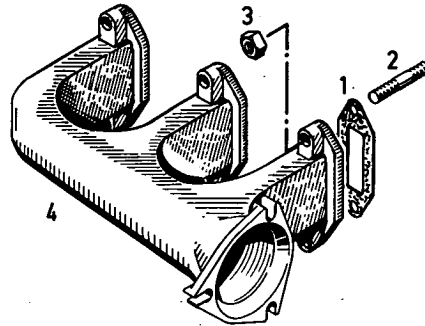

| Bild<br>Nr. | Teile-Nr. | Stück-<br>Zahl |                   |                  |                     |                  | 0150-41 500 6828         |     |
|-------------|-----------|----------------|-------------------|------------------|---------------------|------------------|--------------------------|-----|
|             |           |                | Deutsch           | English          | Français            | Español          | Nummer/Bemerkung         | ETK |
| 1           | 337 1689  | 3              | DICHTUNG          | GASKET           | GARNITURE/JOINT     | JUNTA            | 0155-08-20.99            | 01  |
| 2           | 111 0190  | 6              | STIFTSCHRAUBE     | STUD             | GOUJON              | ESPARRAGO        | M 8X 35 SN4 DIN 835- 8.8 |     |
| 3           | 331 6466  | 6              | SECHSKANTMUTTER   | HEX.NUT          | ECROU 6 PANS        | TUERCA HEXAGONAL | 236 245 D                | 01  |
| 4           | 210 2340  | 1              | AUSPUFFSAMMELROHR | EXHAUST MANIFOLD | COLLECTEUR D'ECHEPT | COLECTOR ESCAPE  | 0150-41-411.02           |     |

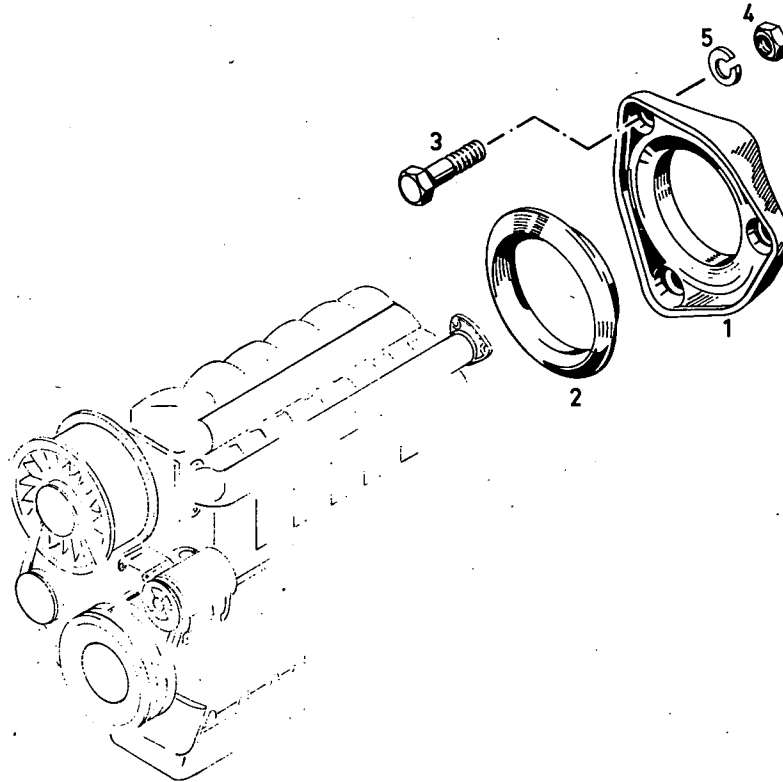
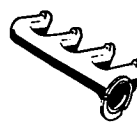

0150-41 500 3629

| Bild Nr. | Teile-Nr. | Stück-Zahl | Deutsch           | English           | Français           | Español            | Nummer/Bemerkung          | ETK |
|----------|-----------|------------|-------------------|-------------------|--------------------|--------------------|---------------------------|-----|
| 1        | 336 6951  | 1          | DREILOCHFLANSCH   | THREE-HOLE FLANGE | BRIDE A TROIS TROU | BRIDA 3 TALADROS   | 0152-41-02.06             |     |
| 2        | 334 8038  | 1          | DICHTUNGSLINSE    | GLANDULAR GASKET  | PASTILLE DE JOINT  | JUNTA LENTICULAR   | 330 61 122                | 1   |
| 3        | 111 1475  | 3          | SECHSKANTSCHRAUBE | HEX. BOLT         | VIS 6 PANS         | TORNILLO HEXAGONAL | M12X 45 DIN 931-M 8.8 A4C |     |
| 4        | 111 2058  | 3          | SECHSKANTMUTTER   | HEX. NUT          | ECROU 6 PANS       | TUERCA HEXAGONAL   | M12 DIN 934-M 8 A4C       |     |
| 5        | 110 2801  | 3          | FEDERRING         | SPRING LOCKWASHER | RONDELLE GROMER    | ARANDELA ELASTICA  | A 12 DIN 128 A4C          |     |



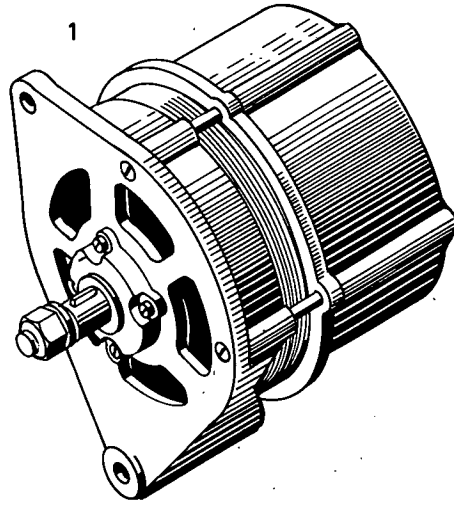

| Bild<br>Nr. | Teile-Nr. | Stück-<br>Zahl |           |           |             |           | 0150-44 500 3709  | Nummer/Bemerkung | ETK |
|-------------|-----------|----------------|-----------|-----------|-------------|-----------|-------------------|------------------|-----|
|             |           |                | Deutsch   | English   | Français    | Español   |                   |                  |     |
| 1           | 116 3985  | 1              | GENERATOR | GENERATOR | GENERATRICE | GENERADOR | J 2RL14X 28H 7612 |                  |     |

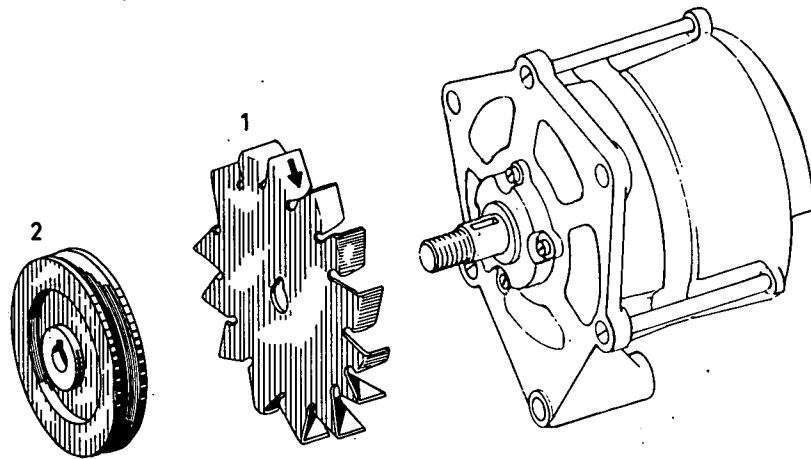

0150-44 500 4597

| Bild Nr. | Teile-Nr. | Stück-Zahl | Deutsch      | English     | Français          | Español      | Nummer/Bemerkung | ETK |
|----------|-----------|------------|--------------|-------------|-------------------|--------------|------------------|-----|
| 1        | 116 3984  | 1          | LUEFTER      | FAN         | VENTILATEUR       | VENTILADOR   | EL 6 H 7612      |     |
| 2        | 216 9842  | 1          | RIEMENSCHIBE | BELT PULLEY | POULIE A COURROIE | POLEA CORREA |                  |     |

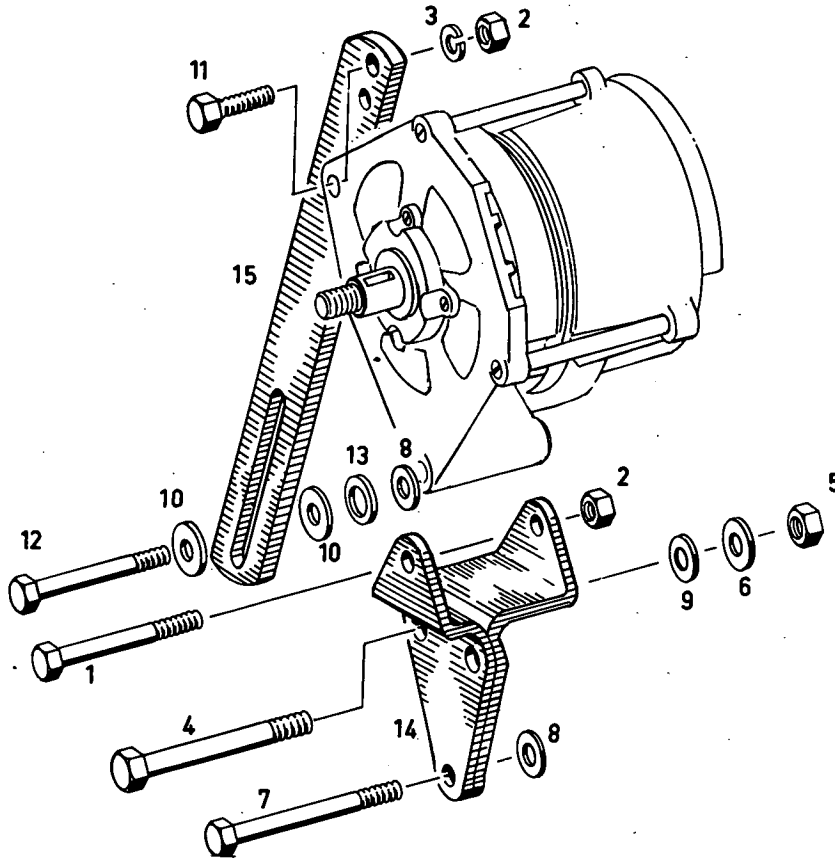

0150-44 500 4572

| Bild Nr. | Teile-Nr. | Stück-Zahl | Deutsch           | English           | Français        | Español            | Nummer/Bemerkung          | ETK |
|----------|-----------|------------|-------------------|-------------------|-----------------|--------------------|---------------------------|-----|
| 1        | 112 3718  | 1          | SECHSKANTSCHRAUBE | HEX. BOLT         | VIS 6 PANS      | TORNILLO HEXAGONAL | M 8 X 80 DIN 931-10.9     |     |
| 2        | 112 2477  | 2          | SECHSKANTMUTTER   | HEX. NUT          | ECROU 6 PANS    | TUERCA HEXAGONAL   | M 8 DIN 934-M10 VZK       |     |
| 3        | 110 2799  | 1          | FEDERING          | SPRING LOCKWASHER | RONDELLE GROMER | ARANDELA ELASTICA  | A 8 DIN 128 A4C           |     |
| 4        | 111 1339  | 1          | SECHSKANTSCHRAUBE | HEX. BOLT         | VIS 6 PANS      | TORNILLO HEXAGONAL | M10 X 80 DIN 931- 8.8-A4C |     |
| 5        | 110 2659  | 1          | SECHSKANTMUTTER   | HEX. NUT          | ECROU 6 PANS    | TUERCA HEXAGONAL   | M10 DIN 934-M 8 A4C       |     |
| 6        | 110 7105  | 1          | SCHEIBE           | DISC/PANE/PLATE   | RONDELLE/DISQUE | DISCO/CRISTAL/PLAT | A10,5DIN 125-ST-A4C       |     |
| 7        | 111 1193  | 1          | SECHSKANTSCHRAUBE | HEX. BOLT         | VIS 6 PANS      | TORNILLO HEXAGONAL | M 8 X 80 DIN 931- 8.8-A4C |     |
| 8        | 121 5748  | 6          | SCHEIBE           | DISC/PANE/PLATE   | RONDELLE/DISQUE | DISCO/CRISTAL/PLAT | 995 H 10                  |     |
| 9        | 121 5749  | 4          | SCHEIBE           | DISC/PANE/PLATE   | RONDELLE/DISQUE | DISCO/CRISTAL/PLAT | 995 H 11                  |     |
| 10       | 121 1206  | 2          | SCHEIBE           | DISC/PANE/PLATE   | RONDELLE/DISQUE | DISCO/CRISTAL/PLAT | Z 308 A 51                |     |
| 11       | 111 2333  | 1          | SECHSKANTSCHRAUBE | HEX. BOLT         | VIS 6 PANS      | TORNILLO HEXAGONAL | M 8 X 25 DIN 933- 8.8-A4C |     |
| 12       | 112 2399  | 1          | SECHSKANTSCHRAUBE | HEX. BOLT         | VIS 6 PANS      | TORNILLO HEXAGONAL | M 8 X 85 DIN 931- 8.8-A4C |     |
| 13       | 110 7101  | 1          | SCHEIBE           | DISC/PANE/PLATE   | RONDELLE/DISQUE | DISCO/CRISTAL/PLAT | A 8,4DIN 125-ST-A4C       |     |
| 14       | 216 6129  | 1          | KONSOLE           | BRACKET/CONSOLE   | CONSOLE         | CONSOLA            |                           |     |
| 15       | 216 6516  | 1          | SPANNLASCHE       | CLAMPING PLATE    | ECLISSE SERRAGE | ECLISA FIADORA     |                           |     |



Schmalkeilriemen  
 Narrow V-belt  
 Courroie trapézoidale étroite  
 Correa trapecial estrecha

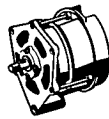

0150-44-500 4562

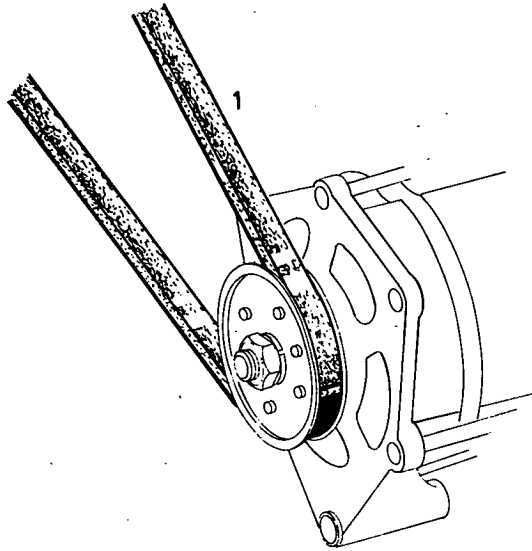

0150-44 500 4562

| Bild Nr. | Teil-Nr. | Stück-Zahl | Deutsch          | English | Français           | Español            | Nummer/Bemerkung | ETK |
|----------|----------|------------|------------------|---------|--------------------|--------------------|------------------|-----|
| 1        | 117 0652 | 1          | SCHMALKEILRIEMEN | V-BELT  | COURR TRAP ETROITE | CORR.TRAPEC.ESTREC | 9,5X1500M 3701   | 01  |

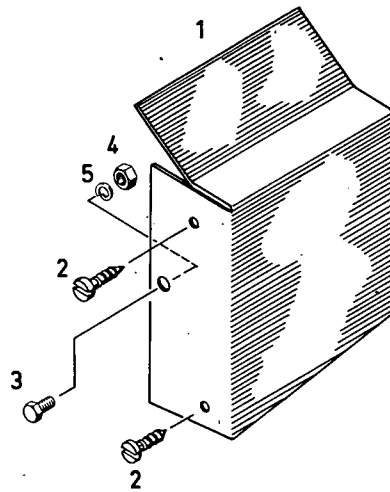

0150-44 500 4567

| Bild Nr. | Teile-Nr. | Stück-Zahl | Deutsch           | English            | Français         | Español            | Nummer/Bemerkung         | ETK |
|----------|-----------|------------|-------------------|--------------------|------------------|--------------------|--------------------------|-----|
| 1        | 216 6522  | 1          | ABSCHIRMBLECH     | SHIELD             | TOLE-ECRAN       | CHAPA PROTECTORA   |                          |     |
| 2        | 111 9302  | 2          | BLECHSCHRAUBE     | SELF-TAPPING SCREW | VIS              | TORNILLO CHAPA     | B 3,9X 9,5DIN 7971       |     |
| 3        | 111 2240  | 1          | SECHSKANTSCHRAUBE | HEX.BOLT           | VIS 6 PANS       | TORNILLO HEXAGONAL | M 6X 12 DIN 933- 8.8-A4C |     |
| 4        | 111 2813  | 1          | SECHSKANTMUTTER   | HEX.NUT            | ECROU 6 PANS     | TUERCA HEXAGONAL   | M 6. DIN 934-M 8 A4C     |     |
| 5        | 110 2797  | 1          | FEDERRING         | SPRING LOCKWASHER  | RONDELLE GROUVER | ARANDELA ELASTICA  | A 6 DIN 128 A4C          |     |



Reglerschalter  
 Regulator cutout  
 Disjoncteur-régulateur  
 Disyuntor



0150-44-500 3706

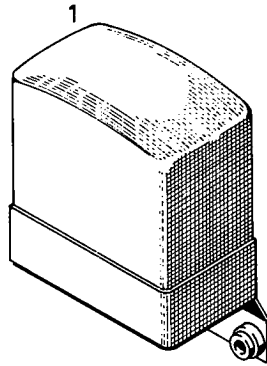

0150-44 500 3706

| Bild Nr. | Teile-Nr. | Stück-Zahl | Deutsch        | English           | Français          | Español   | Nummer / Bemerkung | ETK |
|----------|-----------|------------|----------------|-------------------|-------------------|-----------|--------------------|-----|
| 1        | 116 3008  | 1          | REGLERSCHALTER | REGULATOR/CUT-OUT | REGUL-DISJONCTEUR | DISYUNTOR | T4H 7615           |     |

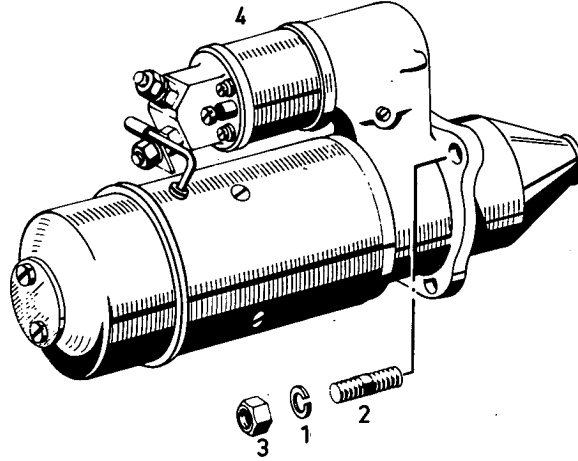
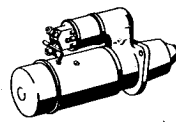

0150-44 500 3651

| Bild Nr. | Teile-Nr. | Stück-Zahl | Deutsch         | English           | Français         | Español           | Nummer/Bemerkung           | ETK |
|----------|-----------|------------|-----------------|-------------------|------------------|-------------------|----------------------------|-----|
| 1        | 11J 2800  | 3          | FEDERRING       | SPRING LOCKWASHER | RENDELLE GROUVER | ARANDELA ELASTICA | A 10 DIN 128 A4C           |     |
| 2        | 11J 2301  | 3          | STIFTSCHRAUBE   | STUD              | GOUJON           | ESPARRAGO         | AM10X 30 DIN 939- 6.8 VZKC |     |
| 3        | 11J 2659  | 3          | SECHSKANTMUTTER | HEX. NUT          | ECROU 6 PANS     | TUERCA HEXAGONAL  | M10 DIN 934-M 8 A4C        |     |
| 4        | 116 4994  | 1          | ANLASSER        | STARTER MOTOR     | DEMARREUR        | ARRANCADOR        | B2BR12X 4 H 7622           |     |



Elektrische Leitungen  
Wiring  
Cables  
Cables



0147-48-501 3458

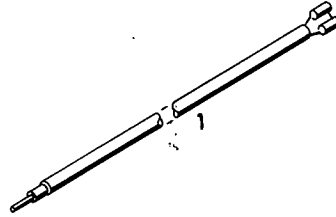

0147-48 501 3458

| Bld Nr. | Teil-Nr. | Stück-Zahl | Deutsch | English        | Français | Español          | Nummer/Bemerkung | ETK |
|---------|----------|------------|---------|----------------|----------|------------------|------------------|-----|
| 1       | 217 9493 | 1          | LEITUNG | PIPE/LINE/LEAD | CONDUITE | TUBERIA/CONDUCTO |                  |     |





2

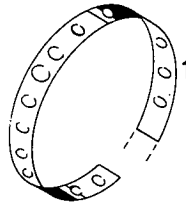

0147-48 500 2446

| Bild Nr. | Teile-Nr. | Stück-Zahl | Deutsch       | English      | Français           | Español            | Nummer/Bemerkung | ETK |
|----------|-----------|------------|---------------|--------------|--------------------|--------------------|------------------|-----|
| 1        | 117 0440  | 4          | KABELLOCHBAND | WIRE STRAP   | RUB PERFORE PR CAB | CINTA PERF.CABLE   | A 50 H 7672      |     |
| 2        | 116 9360  | 4          | LOCHBANDKNDPF | STRAP BUTTON | BOUTON A RUB PERFO | BOTON CINTA PERFOR | A 1 H 7672       |     |



Temperaturkontaktgeber  
Temp. contact maker  
Transmetteur de contact de température  
Transmisor de contacto de temperatura

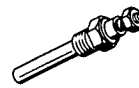

0147-51-501 3456

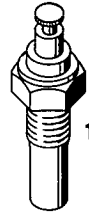

0147-51 501 3456

| Bild Nr. | Teile-Nr. | Stück-Zahl | Deutsch           | English      | Français          | Español          | Nummer/Bemerkung | ETK |
|----------|-----------|------------|-------------------|--------------|-------------------|------------------|------------------|-----|
| 1        | 240 5960  | 1          | TEMPERATURFUEHLER | THERMOSENSOR | SONDE THERMOMETR. | DETECTOR TERMICO |                  |     |



Temperatur-Anzeigegerät  
 Temperature gauge  
 Indicateur température  
 aparato indicador de temperatura

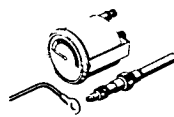

0150-51-500 6877

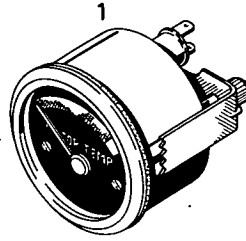

0150-51 500 6877

| Bild Nr. | Teile-Nr. | Stück-Zahl | Deutsch            | English          | Français          | Español            | Nummer/Bemerkung           | ETK |
|----------|-----------|------------|--------------------|------------------|-------------------|--------------------|----------------------------|-----|
| 1        | 116 3773  | 001        | TEMP.ANZEIGEGERAET | TEMPER.INDICATOR | INDIC.TEMPERATURE | AP.INDICAD.TEMPER. | 860X 12VX 30-150-200H 4214 |     |

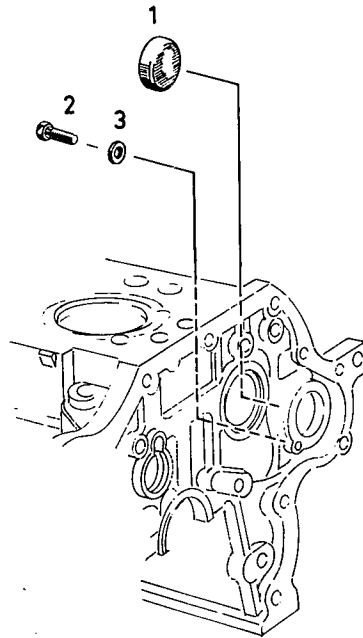
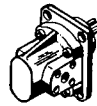

0150-83 500 3812

| Bild Nr. | Teile-Nr. | Stück-Zahl | Deutsch            | English        | Français           | Español            | Nummer/Bemerkung        | ETK |
|----------|-----------|------------|--------------------|----------------|--------------------|--------------------|-------------------------|-----|
| 1        | 116 5839  | 1          | KERNLOCHVERSCHLUSS | CORE HOLE PLUG | BOUCHON TROU DESS  | CIERRE MACHO       | 850 H 711               |     |
| 2        | 121 5567  | 1          | SECHSKANTSCHRAUBE  | HEX. BOLT      | VIS 6 PANS         | TORNILLO HEXAGONAL | 963 W 1                 |     |
| 3        | 111 8659  | 1          | DICHTRING          | WASHER         | BAGUE D'ETANCHEITE | ANILLO DE JUNTA    | A 10 X 13,50 IN 7603-CU |     |

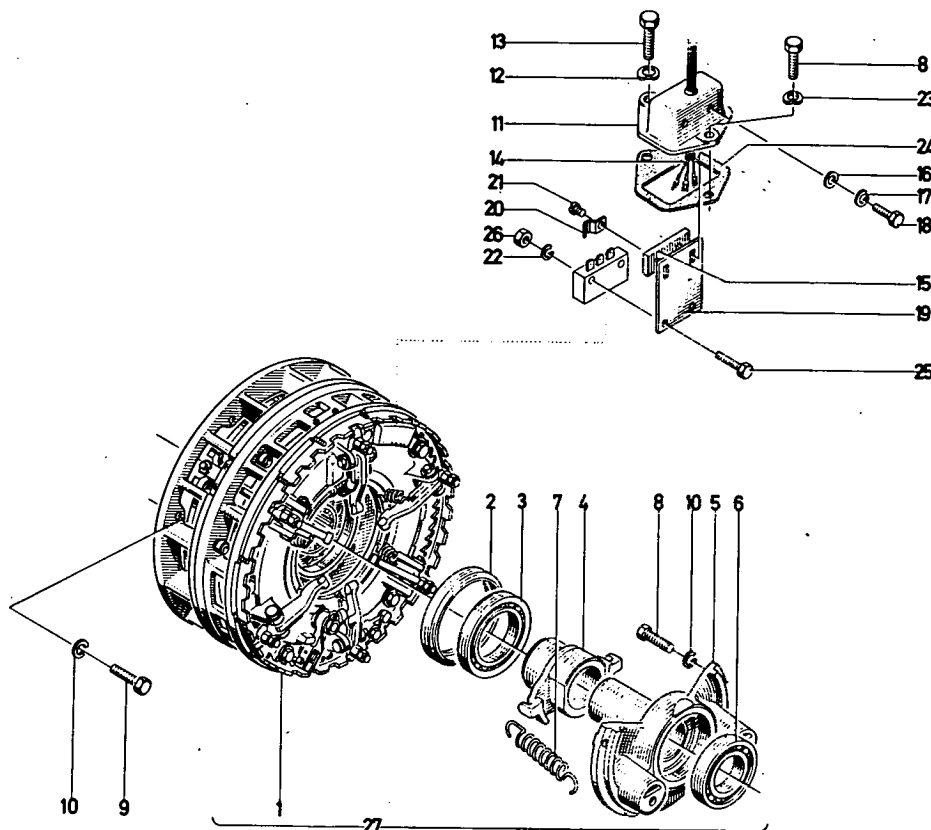

| Bld. Nr. | Teil-Nr. | Stück-Zahl | Deutsch  | English           | Français            | Español             | 1003-02<br>500 6439<br>Nummer/Bemerkung                     | ETK |
|----------|----------|------------|--|-------------------|---------------------|---------------------|---|-----|
| 1        | 232 9758 | 1          | <i>ohne lose Scheibe</i><br>KUPPLUNG<br><i>HT = 294 0229</i> | CLUTCH/COUPLING   | ACCOUPL/EMBRAYAGE   | EMBRAGUE/ACOPLE     | <b>435 0563</b><br>B286, SIEHE TAFEL NO.<br>1003-02 5017148 |     |
| 2        | 232 9760 | 1          | RING   | RING              | BAGUE/ANNEAU        | ANILLO              |   |     |
| 3        | 110 4338 | 1          | RILLENKUGELLAGER   | BALL BEARING      | ROUL. RAINURE BILLE | COJ. BOLAS FIJO     | 6012-2RS DIN 625  | 01  |
| 4        | 232 9761 | 1          | GEHÄUSE  | HOUSING/CASE      | CARTER/BOITIER      | CAJA/BLOQUE/CUERPO  |   |     |
| 5        | 232 9763 | 1          | FLANSCHBUCHSE  | FLANGED BUSH      | DOUILLE A BRIDE     | CASQUILLO BRIDA     |   |     |
| 6        | 110 4339 | 1          | RILLENKUGELLAGER   | BALL BEARING      | ROUL. RAINURE BILLE | COJ. BOLAS FIJO     | 6209-2RS DIN 625  | 01  |
| 7        | 338 9261 | 2          | ZUGFEDER   | DRAW SPRING       | RESSORT TRACTION    | RESORTE TRACCION    | 1145-02-01.06   | 01  |
| 8        | 111 2333 | 4          | SECHSKANTSCHRAUBE  | HEX. BOLT         | VIS 6 PANS          | TORNILLO HEXAGONAL  | M 8 X 25 DIN 933- 8.8-A4C                                   |     |
| 9        | 111 2338 | 6          | SECHSKANTSCHRAUBE  | HEX. BOLT         | VIS 6 PANS          | TORNILLO HEXAGONAL  | M 8 X 30 DIN 933-10.9-A4C                                   |     |
| 10       | 110 2799 | 9          | FEDERRING  | SPRING LOCKWASHER | RONDELLE GROUVER    | ARANDELA ELASTICA   | A 8 DIN 128 A4C   |     |
| 11       | 237 9265 | 1          | KLEMMDECKEL  | CLAMPING COVER    | COUVRE-BORNES       | TAPA APRIETO        | K21003-0202329757UA1003-02 23                               |     |
| 12       | 110 7289 | 1          | FEDERSCHEIBE   | SPRING WASHER     | RONDELLE ELASTIQUE  | ARANDELA ELASTICA   | B12 DIN 137 VZKC  |     |
| 13       | 111 2494 | 1          | SECHSKANTSCHRAUBE  | HEX. BOLT         | VIS 6 PANS          | TORNILLO HEXAGONAL  | M12X 18 DIN 933-M 8.8-A4C                                   |     |
| 14       | 237 9271 | 1          | ELEKTR.-LEITUNGEN  | WIRING            | LIGNES ELECTR.      | LINEAS ELECTRICAS   |   |     |
| 15       | 237 9270 | 1          | KLEMMBAND  | STRAP             | RUBAN DE SEPRAGE    | CINTA APRIETO       |   |     |
| 16       | 110 7095 | 2          | SCHIEBE  | DISC/PANE/PLATE   | RONDELLE/DISQUE     | DISCO/CRISTAL/PLAT  | A 6,4 DIN 125-ST-A4C  |     |
| 17       | 110 2797 | 2          | FEDERRING  | SPRING LOCKWASHER | RONDELLE GROUVER    | ARANDELA ELASTICA   | A 6 DIN 128 A4C   |     |
| 18       | 111 2251 | 2          | SECHSKANTSCHRAUBE  | HEX. BOLT         | VIS 6 PANS          | TORNILLO HEXAGONAL  | M 6 X 15 DIN 933- 8.8-A4C                                   |     |
| 19       | 237 9268 | 1          | HALTEBLECH   | RETAINING PLATE   | TOLE DE RETENUE     | CHAPA SUJECION      |   |     |
| 20       | 110 1179 | 1          | SCHELLE  | CLIP              | COLLIER             | ABRAZADERA          | 7 DIN 72572 VZKC  |     |
| 21       | 110 5501 | 1          | ZYLINDERSCHRAUBE   | CHEESE-HEAD SCREW | VIS TETF CYLINDR.   | TORN. CBZA. CILIND. | AM 4 X 6 DIN 84- 4.8-A4C                                    |     |
| 22       | 110 2795 | 1          | FEDERRING  | SPRING LOCKWASHER | RONDELLE GROUVER    | ARANDELA ELASTICA   | A 4 DIN 128 A4C   |     |
| 23       | 110 7283 | 1          | FEDERSCHEIBE   | SPRING WASHER     | RONDELLE ELASTIQUE  | ARANDELA ELASTICA   | B 8 DIN 137 VZKC  |     |
| 24       | 237 9267 | 1          | FLACHDICHTUNG  | GASKET            | GARNITURE PLATE     | JUNTA PLANA         |   |     |
| 25       | 112 3745 | 2          | SECHSKANTSCHRAUBE  | HEX. BOLT         | VIS 6 PANS          | TORNILLO HEXAGONAL  | M 4 X 20 DIN 933- 8.8-A4C                                   |     |
| 26       | 111 2796 | 2          | SECHSKANTMUTTER  | HEX. NUT          | ECROU 6 PANS        | TUERCA HEXAGONAL    | M 4 DIN 934-M 8 A4C   |     |
| 27       | 232 9756 | 1          | KUPPLUNG   | CLUTCH/COUPLING   | ACCOUPL/EMBRAYAGE   | EMBRAGUE/ACOPLE     |   |     |

Teil-Nummer

Teil-Beschreibung

Ersetzt

125550

238 1687

|           |                        |   |   |          |
|-----------|------------------------|---|---|----------|
| 2 935 060 | Hebel vollst.          | X | 1 | 238 1687 |
| 2 135 044 | Hebel                  |   | 1 |          |
| 0 938 093 | Nadelhülse             | X | 2 |          |
| 2 171 007 | DU-Buchse              | X | 1 |          |
| 2 128 022 | Schaltrolle            | X | 1 |          |
| 0 370 081 | Sicherungsring 8 x 0,8 | X | 1 |          |
| 2 136 021 | Transportklinke        | X | 1 |          |
| 2 171 008 | DU-Buchse              | X | 1 |          |
| 2 145 019 | Bolzen                 | X | 1 |          |
| 0 215 006 | Scheibe 0,5,3          | X | 1 |          |
| 0 491 009 | Splint 1,5 x 10        | X | 1 |          |
| 2 163 040 | Biegefeder             | X | 1 |          |
| 0 451 014 | Spannhülse 4x16        | X | 1 |          |
| 2 145 017 | Bolzen                 | X | 1 | 238 1697 |
| 2 158 034 | Scheibe                | X | 1 | 238 1698 |
| 2 158 035 | Sicherungsblech        | X | 1 | 238 1699 |
| 2 158 027 | Scheibe                | X | 1 | 238 2446 |
| 2 163 038 | Schenkelfeder          | X | 1 | 238 2447 |
| 2 128 021 | Napf                   | X | 1 | 238 2448 |
| 0 493 007 | Splint 3x20            | X | 1 | 110 6432 |

Rep. Satz 238 5124

A-Nr.      Änderung      Datum      Name      gepr.      Buchst.      Bemerkung

Bezeichnung: Reparatursatz Transporttheile  
für Wechsellkupplung  
2 025 010/017/022-01/025  
2 025 018

Lamellen- und Kupplungsbau  
GmbH  
Bühl/Gaden

Nr. 238 5124  
2 025 035













| Teil-Nr.     | Teil-Bezeichnung                              | Menge | Einheit | Norm      |
|--------------|---|-------|---------|-----------|
| 2 025 022 01 | Wechselkupplung vollst.                       | 1     |         | 232 9758  |
| 2 425 032 01 | a.Z. Wechselkupplungol Scheibe u. Schaltgeber | 1     |         |           |
| 2 571 020    | a.Z. Gehäuse Oberteil vollst.                 | 1     |         |           |
| 2 151 019    | Gehäuse Oberteil                              | 1     |         | 2 201 050 |
| 2 152 013    | Schalterschraube                              | 6     |         |           |
| 2 112 071    | Schaltung                                     | 1     |         |           |
| 0 026 001    | a.Z. Sechskantschraube M6x25                  | 3     |         | DIN 933   |
| 2 153 033    | Führungsscheibe                               | 3     |         |           |
| 0 256 016    | a.Z. Federring B6                             | 3     |         | DIN 117   |
| 0 216 001    | a.Z. Sechskantmutter M6                       | 3     |         | DIN 934   |
| 2 926 017    | Hebel vollst.                                 | 1     |         | 237 9117  |
| 2 136 017    | Hebel   | 1     |         | 2 236 018 |
| 2 171 007    | DU-Buchse                                     | 2     |         | MB 0810   |
| 2 145 016    | Bolzen mit Kopf                               | 1     |         |           |
| 0 343 002    | a.Z. Federscheibe B8                          | 1     |         | DIN 137   |
| 0 343 004    | a.Z. Scheibe Ø 84                             | 1     |         | DIN 433   |
| 0 493 001    | a.Z. Splint 3x15                              | 1     |         | DIN 94    |
| 2 161 003    | Zugfeder                                      | 1     |         |           |
| 2 936 018    | Hebel vollst.                                 | 5     |         | 237 9117  |
| 2 136 017    | Hebel   | 5     |         | 2 236 018 |
| 2 171 007    | DU-Buchse                                     | 10    |         | MB 0810   |
| 2 145 051    | Bolzen  | 5     |         | 237 9618  |
| 0 318 004    | a.Z. Scheibe Ø 84                             | 5     |         | DIN 433   |
| 0 493 001    | a.Z. Splint 3x15                              | 5     |         | DIN 94    |
| 0 318 004    | a.Z. Scheibe Ø 84                             | 5     |         | DIN 433   |
| 0 493 001    | a.Z. Splint 3x15                              | 5     |         | DIN 94    |
| 2 161 003    | Zugfeder                                      | 5     |         | 237 9619  |
| 2 529 001    | Magnethalter vollst.                          | 1     |         |           |
| 2 129 032    | Magnethalter                                  | 1     |         |           |
| 2 194 011    | Magnet  | 2     |         |           |
| 2 158 034    | Abdeckblech                                   | 1     |         |           |
| 0 003 001    | a.Z. Zylinderschraube M3x8                    | 1     |         | DIN 84    |
| 0 015 009    | a.Z. Sechskantschraube M5x35                  | 2     |         | DIN 931   |
| 0 316 005    | a.Z. Scheibe Ø 64                             | 2     |         | DIN 433   |

Reparat. für Motorschalle

| Nr. | A-Nr. | Änderung            | Datum   | Name   | gepr. | Buchst. | Bemerkung |
|-----|-------|---------------------|---------|--------|-------|---------|-----------|
| a   | 10972 | Serie neu           | 18.73   | Gr. J. |       |         |           |
| b   | 13695 | Serie wird gelöscht | 28.6.76 | Zli.   |       |         |           |

**Sario**

**VERTRÄGLICHKEIT**

SIEHE AUCH DIN 84-2.1

Ersetzt für: **232 9758**

Ersetzt durch:

**Wechselkupplung**

2 025 022 01

Funktionen- und Kupplungstau  
 8.11.14  
 2.11.15

|               |  |   |         |
|---------------|--|---|---------|
| 2 100 000 01  |  | 1 | 232 975 |
| 2 100 000 02  |  | 1 |         |
| 2 100 000 03  |  | 1 |         |
| 2 100 000 04  |  | 1 |         |
| 2 100 000 05  |  | 1 |         |
| 2 100 000 06  |  | 1 |         |
| 2 100 000 07  |  | 1 |         |
| 2 100 000 08  |  | 1 |         |
| 2 100 000 09  |  | 1 |         |
| 2 100 000 10  |  | 1 |         |
| 2 100 000 11  |  | 1 |         |
| 2 100 000 12  |  | 1 |         |
| 2 100 000 13  |  | 1 |         |
| 2 100 000 14  |  | 1 |         |
| 2 100 000 15  |  | 1 |         |
| 2 100 000 16  |  | 1 |         |
| 2 100 000 17  |  | 1 |         |
| 2 100 000 18  |  | 1 |         |
| 2 100 000 19  |  | 1 |         |
| 2 100 000 20  |  | 1 |         |
| 2 100 000 21  |  | 1 |         |
| 2 100 000 22  |  | 1 |         |
| 2 100 000 23  |  | 1 |         |
| 2 100 000 24  |  | 1 |         |
| 2 100 000 25  |  | 1 |         |
| 2 100 000 26  |  | 1 |         |
| 2 100 000 27  |  | 1 |         |
| 2 100 000 28  |  | 1 |         |
| 2 100 000 29  |  | 1 |         |
| 2 100 000 30  |  | 1 |         |
| 2 100 000 31  |  | 1 |         |
| 2 100 000 32  |  | 1 |         |
| 2 100 000 33  |  | 1 |         |
| 2 100 000 34  |  | 1 |         |
| 2 100 000 35  |  | 1 |         |
| 2 100 000 36  |  | 1 |         |
| 2 100 000 37  |  | 1 |         |
| 2 100 000 38  |  | 1 |         |
| 2 100 000 39  |  | 1 |         |
| 2 100 000 40  |  | 1 |         |
| 2 100 000 41  |  | 1 |         |
| 2 100 000 42  |  | 1 |         |
| 2 100 000 43  |  | 1 |         |
| 2 100 000 44  |  | 1 |         |
| 2 100 000 45  |  | 1 |         |
| 2 100 000 46  |  | 1 |         |
| 2 100 000 47  |  | 1 |         |
| 2 100 000 48  |  | 1 |         |
| 2 100 000 49  |  | 1 |         |
| 2 100 000 50  |  | 1 |         |
| 2 100 000 51  |  | 1 |         |
| 2 100 000 52  |  | 1 |         |
| 2 100 000 53  |  | 1 |         |
| 2 100 000 54  |  | 1 |         |
| 2 100 000 55  |  | 1 |         |
| 2 100 000 56  |  | 1 |         |
| 2 100 000 57  |  | 1 |         |
| 2 100 000 58  |  | 1 |         |
| 2 100 000 59  |  | 1 |         |
| 2 100 000 60  |  | 1 |         |
| 2 100 000 61  |  | 1 |         |
| 2 100 000 62  |  | 1 |         |
| 2 100 000 63  |  | 1 |         |
| 2 100 000 64  |  | 1 |         |
| 2 100 000 65  |  | 1 |         |
| 2 100 000 66  |  | 1 |         |
| 2 100 000 67  |  | 1 |         |
| 2 100 000 68  |  | 1 |         |
| 2 100 000 69  |  | 1 |         |
| 2 100 000 70  |  | 1 |         |
| 2 100 000 71  |  | 1 |         |
| 2 100 000 72  |  | 1 |         |
| 2 100 000 73  |  | 1 |         |
| 2 100 000 74  |  | 1 |         |
| 2 100 000 75  |  | 1 |         |
| 2 100 000 76  |  | 1 |         |
| 2 100 000 77  |  | 1 |         |
| 2 100 000 78  |  | 1 |         |
| 2 100 000 79  |  | 1 |         |
| 2 100 000 80  |  | 1 |         |
| 2 100 000 81  |  | 1 |         |
| 2 100 000 82  |  | 1 |         |
| 2 100 000 83  |  | 1 |         |
| 2 100 000 84  |  | 1 |         |
| 2 100 000 85  |  | 1 |         |
| 2 100 000 86  |  | 1 |         |
| 2 100 000 87  |  | 1 |         |
| 2 100 000 88  |  | 1 |         |
| 2 100 000 89  |  | 1 |         |
| 2 100 000 90  |  | 1 |         |
| 2 100 000 91  |  | 1 |         |
| 2 100 000 92  |  | 1 |         |
| 2 100 000 93  |  | 1 |         |
| 2 100 000 94  |  | 1 |         |
| 2 100 000 95  |  | 1 |         |
| 2 100 000 96  |  | 1 |         |
| 2 100 000 97  |  | 1 |         |
| 2 100 000 98  |  | 1 |         |
| 2 100 000 99  |  | 1 |         |
| 2 100 000 100 |  | 1 |         |

| Art.   | Abk.                       | Abk. ung | Best. Name | gr.  | Licht | Formberg |
|--|----------------------------|----------|------------|------|-------|----------|
| a  | 10972                      | 1873     | 1873       | 1873 |       |          |
| b  | Ausserung gelöscht in 1873 |          |            |      |       |          |
| <div style="border: 1px solid black; padding: 5px; display: inline-block;">             12.4.73<br/>             232 9758           </div> |                            |          |            |      |       |          |
| <div style="border: 1px solid black; padding: 5px; display: inline-block;">             Wechselkupplung           </div>                   |                            |          |            |      |       |          |

Teil-Nummer

Teil-Beschreibung

122616

|              |    |                                      |    |           |
|--------------|----|--------------------------------------|----|-----------|
| 2 025 022 01 |    | Wickelkupplung vollst.               | 1  | 232 97576 |
| 2 025 022 02 | oZ | Wickelkupplung obere Schaltegetriebe | 1  |           |
| 2 025 022 03 | oZ | Gehäuse Oberteil vollst.             | 1  |           |
| 2 025 022 04 |    | Gehäuse Oberteil                     | 1  | 2 201 059 |
| 2 025 022 05 |    | Schaltstange                         | 8  |           |
| 2 025 022 06 |    | Schaltstange                         | 7  |           |
| 0 226 022 07 | oZ | Sechskantschraube M6x25              | 3  | DIN 934   |
| 2 025 022 08 |    | Führungsscheibe                      | 3  |           |
| 0 226 022 09 | oZ | Federling Ø 16                       | 3  | DIN 123   |
| 0 226 022 10 | oZ | Sechskantmutter M6                   | 3  | DIN 934   |
| 2 936 017    |    | Hebel vollst.                        | 1  | 237 9619  |
| 2 136 017    |    | Hebel                                | 1  | 2 236 017 |
| 2 171 017    |    | DU-Buchse                            | 2  | MB 0810   |
| 2 145 016    |    | Bolzen mit Kopf                      | 1  |           |
| 0 318 004    | oZ | Federplatte Ø 84                     | 1  | DIN 123   |
| 0 493 001    | oZ | Splint Ø 84                          | 1  | DIN 94    |
| 0 493 001    | oZ | Splint 3x15                          | 1  | DIN 94    |
| 2 161 003    |    | Zugfeder                             | 1  |           |
| 2 936 018    |    | Hebel vollst.                        | 5  | 237 9619  |
| 2 136 018    |    | Hebel                                | 5  | 2 236 018 |
| 2 171 018    |    | DU-Buchse                            | 10 | MB 0810   |
| 2 145 051    |    | Bolzen                               | 5  | 237 9618  |
| 0 318 004    | oZ | Scheibe Ø 84                         | 5  | DIN 433   |
| 0 493 001    | oZ | Splint 3x15                          | 5  | DIN 94    |
| 0 318 004    | oZ | Scheibe Ø 84                         | 5  | DIN 433   |
| 0 493 001    | oZ | Splint 3x15                          | 5  | DIN 94    |
| 2 161 003    |    | Zugfeder                             | 5  | 237 9619  |
| 2 939 001    |    | Magnethalter vollst.                 | 1  |           |
| 2 129 032    |    | Magnethalter                         | 1  |           |
| 2 159 034    |    | Magnet                               | 2  |           |
| 2 159 034    |    | Abdeckblech                          | 1  |           |
| 0 083 071    | oZ | Zylinderschraube M3x8                | 1  | DIN 84    |
| 0 015 009    | oZ | Sechskantschraube M6x35              | 2  | DIN 934   |
| 0 318 004    | oZ | Scheibe Ø 64                         | 2  | DIN 433   |

Rep. ratig  
 für Magnetschalter

| A.-Nr.  | Änderung            | Datum   | Name   | gepr. | Suchst. | Bemerkung |
|---|---------------------|---------|--------|-------|---------|-----------|
| a 10972   | Serie neu           | 18.73   | St. J. |       |         |           |
| b 13695   | Serie wird gelöscht | 28.6.76 | St. J. |       |         |           |
| <b>VERTRAGSGEBER</b><br><b>VERTRAGSNUMMER</b><br><b>SIEMENS</b><br><b>SIEMENS AG</b><br><b>WIRTSCHAFTSABTEILUNG</b><br><b>POSTFACH 1015</b><br><b>8000 MÜNCHEN 90</b><br><b>TELEFON (089) 35-3331</b><br><b>TELEFAX (089) 35-3332</b><br><b>TELEGRAMM: SIE 2221</b><br><b>TELEX: 7101 SIEDE D</b><br><b>SEITE AUCH DIN 3401</b> |                     |         |        |       |         |           |
| Koll. Anbau<br>für Einbauelemente<br>auf Oberblech  |                     |         |        |       |         |           |
| 12.4.73<br>12.4.73<br>Ersetzt durch:  |                     |         |        |       |         |           |
| Zeichnung: 232 9758<br><b>Wechselkupplung</b>   |                     |         |        |       |         |           |
| 2 025 022 01  |                     |         |        |       |         |           |









|    |              |      |  |  |   |              |
|----|--------------|------|--|--|---|--------------|
| 4  | 121 011      |      |  |  | 1 | 238 2552     |
| 5  | 140 027      |      |  |  | 2 | 238 2552     |
| 6  | 2 103 154    |      |  |  | 1 | 2 203 146    |
| 7  | 2 053 014    |      |  |  | 3 | 238 2552     |
| 8  | 2 152 017    |      |  |  | 3 |              |
| 9  | 2 152 012    |      |  |  | 3 |              |
| 10 | 2 152 014    |      |  |  | 3 |              |
| 11 | 2 129 031    |      |  |  | 3 |              |
| 12 | 2 154 018    |      |  |  | 3 |              |
| 13 | 2 155 120    |      |  |  | 3 |              |
| 14 | 0 370 041    | o.Z. |  |  | 3 | DIN 6198     |
| 15 | 2 155 031    |      |  |  | 6 |              |
| 16 | 0 029 003    | o.Z. |  |  | 6 | DIN 933      |
| 17 | 2 158 032    |      |  |  | 3 |              |
| 18 | 2 155 022    |      |  |  | 3 |              |
| 19 | 0 228 001    | o.Z. |  |  | 3 | DIN 936      |
| 20 |              |      |  |  |   |              |
| 21 | 3 025 732 01 |      |  |  | 1 | 238 2563     |
| 22 |              |      |  |  |   |              |
| 23 | 2 901 016    | o.Z. |  |  | 1 | 238 2564     |
| 24 | 2 101 060    |      |  |  | 1 | 2 201 060    |
| 25 | 0458 012     | o.Z. |  |  | 6 | DIN 148      |
| 26 | 0455 013     | o.Z. |  |  | 6 | DIN 148      |
| 27 |              |      |  |  |   |              |
| 28 | 0 358 005    | o.Z. |  |  | 6 | DIN 127      |
| 29 | 0 058 001    | o.Z. |  |  | 6 | DIN 912      |
| 30 |              |      |  |  |   |              |
| 31 | 2 140 037    |      |  |  | 2 | 238 2552     |
| 32 | 2 112 020    |      |  |  | 1 |              |
| 33 | 0 909 023    | o.Z. |  |  | 6 | III DIN 5401 |
| 34 | 4 121 011    |      |  |  | 1 |              |
| 35 | 2 140 037    |      |  |  | 2 |              |
| 36 |              |      |  |  |   |              |
| 37 | 2 103 154    |      |  |  | 1 | 2 203 146    |
| 38 | 2 953 002    |      |  |  | 3 | 238 2552     |
| 39 |              |      |  |  |   |              |
| 40 |              |      |  |  |   |              |
| 41 |              |      |  |  |   |              |
| 42 |              |      |  |  |   |              |
| 43 |              |      |  |  |   |              |

| A-Nr.   | Änderung            | Datum   | Name | grpr. | Buchst. | Bemerkung |
|---------|---------------------|---------|------|-------|---------|-----------|
| a 10972 | Serie neu           | 18.7.73 |      |       |         |           |
| b 13695 | Serie wird gelöscht | 23.6.73 |      |       |         |           |

**VERAULN**

SIEHE AUCH DIN 34.21

|       |         |                |
|-------|---------|----------------|
| Name  | Datum   | Ersatz für:    |
| Stulz | 12.4.73 |                |
| grpr. |         | Ersetzt durch: |
|       |         |                |

Berichtigung:

Wechselkupplung

Lamellen- und Kupplungsbau  
GmbH  
Bühl/Eaden

Stückliste Nr. 2 025 022 01

| Teil-Nummer  | Teil-Bezeichnung                | Stückzahl | Norm            |
|--------------|---------------------------------|-----------|-----------------|
| 4 121 011    | Tellerfeder                     | 1         | 238 2552        |
| 2 140 037    | Bolzen                          | 2         | 238 2552        |
| 2 103 154    | Druckplatte                     | 1         | 2 203 146       |
| 2 953 001    | Ausrückgabel vollst.            | 3         | 238 2556        |
| 2 953 007    | Ausrückgabel geschw. Df         | 3         |                 |
| 2 153 002    | Ausrückgabel                    | 3         |                 |
| 2 152 014    | Gewindestift                    | 3         |                 |
| 2 129 031    | Lagerriegel                     | 3         |                 |
| 2 154 018    | Rolle $\phi$ 16x9               | 3         |                 |
| 2 145 020    | Bolzen                          | 3         |                 |
| 0 370 041    | a.Z. Sicherungsscheibe $\phi$ 4 | 3         | DIN 6799        |
| 2 158 031    | Sicherungsblech                 | 6         |                 |
| 0 028 003    | a.Z. Sechskantschraube M8x16    | 6         | DIN 933         |
| 2 158 032    | Scheibe                         | 3         |                 |
| 2 155 022    | Sondermutter M8x1               | 3         |                 |
| 0 228 001    | a.Z. Sechskantmutter M8x1       | 3         | DIN 936         |
| 3 025 732 01 | Kupplungsscheibe                | 1         | 238 2563        |
| 2 901 016    | a.Z. Gehäuse Unterteil vollst.  | 1         | 238 2564        |
| 2 101 060    | Gehäuse Unterteil               | 1         | 2 201 060       |
| 0 458 012    | a.Z. Spannhülse 8x36            | 6         | DIN 148         |
| 0 455 013    | a.Z. Spannhülse 5x36            | 6         | DIN 148         |
| 0 358 005    | a.Z. Federring B 8              | 6         | DIN 127         |
| 0 058 001    | a.Z. Zylinderschraube M8x25     | 6         | DIN 912         |
| 2 140 037    | Bolzen                          | 2         | 238 2552        |
| 2 112 020    | Abstützring                     | 1         |                 |
| 0 909 003    | a.Z. Kugel $\phi$ 12            | 6         | KI III DIN 5401 |
| 4 121 011    | Tellerfeder                     | 1         |                 |
| 2 140 037    | Bolzen                          | 2         |                 |
| 2 103 154    | Druckplatte                     | 1         | 2 203 146       |
| 2 953 002    | Ausrückgabel vollst.            | 3         | 238 2556        |

| Zelle | A-Nr. | Änderung            | Datum   | Name  | gepr. | Buchst. | Bemerkung |
|-------|-------|---------------------|---------|-------|-------|---------|-----------|
| a     | 10972 | Serie neu           | 1.8.73  | A. J. |       |         |           |
| b     | 13695 | Serie wird gelöscht | 28.6.73 | Klein |       |         |           |

**HYDRAULIK**

**DIESEN UNTERTEIL MIT DEN SCHRAUBEN**

**SIEHE AUCH DIN 34.2.1**

Informationspause

|                           |            |
|---------------------------|------------|
| Kein Änderungsantrag      | Name       |
| Für Fertigung und Montage | Zustimmung |

20. Dez. 1976

|                    |         |                |
|--------------------|---------|----------------|
| Name               | Datum   | Ersatz für:    |
| gef. <i>Schub</i>  | 12.4.73 |                |
| gepr. <i>Schub</i> |         | Ersetzt durch: |

Wechselkupplung

Stückliste Nr. 2 025 022 01

| Stück-Nr.    | Bezeichnung                     | Menge | Einheit | Norm           |
|--------------|---------------------------------|-------|---------|----------------|
| 4 121 011    | Federfeder                      | 1     |         | 238 2552       |
| 2 140 037    | Feder                           | 2     |         | 238 2552       |
| 2 122 154    | Druckplatte                     | 1     |         | 2 203 146      |
| 2 53 001     | Ausrückgabel vollst.            | 3     |         | 238 2556       |
| 2 953 002    | Ausrückgabel geschw.            | 3     |         |                |
| 2 53 002     | Ausrückgabel                    | 3     |         |                |
| 2 152 014    | Gewindestift                    | 3     |         |                |
| 2 129 031    | Lagerriegel                     | 3     |         |                |
| 2 154 018    | Rolle $\phi$ 16x9               | 3     |         |                |
| 2 145 020    | Einlen                          | 3     |         |                |
| 0 370 041    | a.Z. Sicherungsscheibe $\phi$ 4 | 3     |         | DIN 6795       |
| 2 158 031    | Sicherungsblech                 | 6     |         |                |
| 0 028 003    | a.Z. Sechskantschraube M8x16    | 6     |         | DIN 933        |
| 2 158 032    | Scheibe                         | 3     |         |                |
| 2 155 022    | Sondermutter M8x1               | 3     |         |                |
| 0 228 001    | a.Z. Sechskantsmutter M8x1      | 3     |         | DIN 936        |
| 3 025 732 01 | Kupplungsscheibe                | 1     |         | 238 2563       |
| 2 901 016    | a.Z. Gehäuse Unterteil vollst.  | 1     |         | 238 2564       |
| 2 101 060    | Gehäuse Unterteil               | 1     |         | 2 201 060      |
| 0458 012     | a.Z. Spannhülse 8x36            | 6     |         | DIN 148        |
| 0455 013     | a.Z. Spannhülse 5x36            | 6     |         | DIN 148        |
| 0 358 005    | a.Z. Federring B 8              | 6     |         | DIN 127        |
| 0 058 001    | a.Z. Zylinderschraube M8x25     | 6     |         | DIN 912        |
| 2 140 037    | Bolzen                          | 2     |         | 238 2552       |
| 2 112 020    | Abstützring                     | 1     |         |                |
| 0 909 003    | a.Z. Kugel $\phi$ 12            | 6     |         | KL II DIN 5401 |
| 4 121 011    | Federfeder                      | 1     |         |                |
| 2 140 037    | Bolzen                          | 2     |         |                |
| 2 103 154    | Druckplatte                     | 1     |         | 2 203 146      |
| 2 953 002    | Ausrückgabel vollst.            | 3     |         | 238 2556       |

| A-Nr.   | Änderung            | Datum   | Name | gepr. | Buchst. | Bemerkung |
|---------|---------------------|---------|------|-------|---------|-----------|
| a 10972 | Serie neu           | 18.7.73 | ...  |       |         |           |
| b 13695 | Serie wird gelöscht | 28.6.73 | ...  |       |         |           |

**STRAUSS**

**DRINGENDE WARTUNG**

**SIEHE AUCH DIN 34.2.1**

|                    |         |               |
|--------------------|---------|---------------|
| Name               | Datum   | Ersatz für:   |
| gsl. <i>Stulz</i>  | 12.4.73 |               |
| gepr. <i>Stulz</i> |         | Ersatz durch: |

Einerklärung:

## Wechselkupplung

Stückliste Nr. 2 025 022 01

Informationenhaus  
 Kein Änderungsantrag  
 Nach Bestätigung  
 für Fertigung zur  
 Zusammenbau

**20. Dez. 1973**

Lamellen- und Kupplungsbau  
 GmbH  
 Buhl / Eaden

10972

10972

|              |     |  |                           |   |          |                     |
|--------------|-----|--|---------------------------|---|----------|---------------------|
| 2 042 009    |     |  |                           |   |          |                     |
| 2 042 012    |     |  |                           |   |          |                     |
| 2 042 015    |     |  |                           |   |          |                     |
| 2 129 001    |     |  |                           |   |          |                     |
| 2 129 018    |     |  |                           |   |          |                     |
| 2 129 020    |     |  |                           |   |          |                     |
| 2 129 021    | 0,2 |  | Sicherungscheibe d. 4     |   |          |                     |
| 2 153 031    |     |  | Sicherungssech            | 6 |          |                     |
| 0 025 003    | 0,2 |  | Sechskantschraube M8x16   | 6 | DIN 933  |                     |
| 2 153 032    |     |  | Sechse                    | 3 | 238 2568 |                     |
| 2 153 032    |     |  | Sechsnutler M8x1          | 3 |          |                     |
| 0 228 001    | 0,2 |  | Sechsvorbohrer M6x1       | 3 | DIN 938  |                     |
| 3 042 733 01 |     |  | Kupplungscheibe           | 1 | 238 2568 |                     |
| 2 198 001    |     |  | Schaltgehäuse vollst.     | 1 |          |                     |
| 2 198 002    |     |  | Schaltgehäuse             | 1 |          |                     |
| 2 198 003    |     |  | selbstfließend. Etiketten | 2 | 238 2568 | besteht aus 2 Stück |
| (2 198 004)  |     |  | Schaltbild                |   |          |                     |

| Ä-Nr.   | Änderung            | Datum  | Name | Gr. r. | Buchst. | Bemerkung |
|---------|---------------------|--------|------|--------|---------|-----------|
| a 10972 | Serie neu           | 1.8.73 | ...  |        |         |           |
| b 12695 | Serie wird gelöscht | ...    | ...  |        |         |           |

INFORMATIONEN  
 DIESE ZEITUNG  
 ...

Informationen  
 ...  
 21. Dez 1973

Bestell-Nr.: 12 673  
 ...  
**Wechselkupplung**

Lamellen- und Kupplungsbau GmbH  
 ...  
 Stückliste Nr. 2 025 022 01

Teil-Nr.

Teilbezeichnung

|    |              |    |                               |  |                     |
|----|--------------|----|-------------------------------|--|---------------------|
| 1  |              |    |                               |  |                     |
| 2  | 2 158 001    |    |                               |  |                     |
| 3  | 2 158 001    |    |                               |  |                     |
| 4  | 2 158 001    |    |                               |  |                     |
| 5  | 0 025 001    | oZ | Serie abgeschaltet y 4        |  |                     |
| 6  | 2 158 001    |    | Schaltungsblech               |  |                     |
| 7  | 0 025 003    | oZ | Sechskantschraube M8x16       |  | DIN 933             |
| 8  | 2 158 001    |    | Scheibe                       |  | 238 2561            |
| 9  | 2 158 002    |    | Sechskantschraube M8x1        |  | DIN 933             |
| 10 | 0 025 001    | oZ | Sechskantschraube M8x1        |  | DIN 933             |
| 11 | 3 025 733 01 |    | Kupplungsgehäuse              |  | 238 2561            |
| 12 | 2 198 001    |    | Schaltgehäuse vollst.         |  |                     |
| 13 | 2 198 002    |    | Schaltgeh.                    |  |                     |
| 14 | 2 198 003    |    | selbsttätige Fühlst. 238 2568 |  | besteht aus 2 Stück |
| 15 | (2 198 004)  |    | Schaltblech                   |  |                     |
| 16 |              |    |                               |  |                     |
| 17 |              |    |                               |  |                     |
| 18 |              |    |                               |  |                     |
| 19 |              |    |                               |  |                     |
| 20 |              |    |                               |  |                     |
| 21 |              |    |                               |  |                     |
| 22 |              |    |                               |  |                     |
| 23 |              |    |                               |  |                     |
| 24 |              |    |                               |  |                     |
| 25 |              |    |                               |  |                     |
| 26 |              |    |                               |  |                     |
| 27 |              |    |                               |  |                     |
| 28 |              |    |                               |  |                     |
| 29 |              |    |                               |  |                     |
| 30 |              |    |                               |  |                     |
| 31 |              |    |                               |  |                     |
| 32 |              |    |                               |  |                     |
| 33 |              |    |                               |  |                     |
| 34 |              |    |                               |  |                     |
| 35 |              |    |                               |  |                     |
| 36 |              |    |                               |  |                     |
| 37 |              |    |                               |  |                     |
| 38 |              |    |                               |  |                     |
| 39 |              |    |                               |  |                     |
| 40 |              |    |                               |  |                     |
| 41 |              |    |                               |  |                     |
| 42 |              |    |                               |  |                     |
| 43 |              |    |                               |  |                     |

| Ä-Nr.   | Änderung          | Datum   | Änder. gepr. | Buchst. | Bemerkung |
|---------|-------------------|---------|--------------|---------|-----------|
| a 10972 | Serie neu         | 1.8.73  | 47           |         |           |
| b 13695 | Serie wird gelöst | 12.6.73 | 75           |         |           |

**WIKI-BAUWERKZEUGE**  
 DANKEN ÜBER...  
 12.6.73  
 21. Dez. 1973  
**Wechselkupplung**

TECHNISCHE ZEICHENLISTE

Teil-Nummer

Teil-Bezeichnung

1 2 3 4 5 6

|    |              |      |                          |   |                     |
|----|--------------|------|--------------------------|---|---------------------|
| 3  | 2 55 008     |      | Ausrückerst. geschw. St. | 3 |                     |
| 4  | 2 55 012     |      | Ausrückerst. geschw. St. | 3 |                     |
| 5  | 2 55 015     |      | Gewindestift             | 3 |                     |
| 7  | 2 129 031    |      | Lagerriegel              | 3 |                     |
| 8  | 2 155 018    |      | Rolle Ø 10x9             | 3 |                     |
| 9  | 2 145 020    |      | Wellen                   | 3 |                     |
| 11 | 0 370 001    | a.Z. | Sicherungscheibe Ø 4     | 3 | DIN 5705            |
| 12 | 2 158 031    |      | Sicherungsblech          | 6 |                     |
| 13 | 0 028 003    | a.Z. | Sechskantschraube M8x16  | 6 | DIN 933             |
| 15 | 2 158 032    |      | Scheibe                  | 3 | 238 2561            |
| 16 | 2 155 022    |      | Sechskantmutter M8x1     | 3 |                     |
| 17 | 0 228 001    | a.Z. | Sechskantmutter M8x1     | 3 | DIN 936             |
| 19 | 3 025 733 01 |      | Kupplungscheibe          | 1 | 238 2566            |
| 21 | 2 906 001    |      | Schaltgeber vollst.      | 1 |                     |
| 22 | 2 198 002    |      | Schaltgeber              | 1 |                     |
| 23 | 2 198 003    |      | selbstklebende Etiketten | 1 | 238 2568            |
| 24 | (2 198 004)  |      | Schalbild                | 1 | besteht aus 2 Stück |
| 25 |              |      |                          |   |                     |
| 26 |              |      |                          |   |                     |
| 27 |              |      |                          |   |                     |
| 28 |              |      |                          |   |                     |
| 29 |              |      |                          |   |                     |
| 30 |              |      |                          |   |                     |
| 31 |              |      |                          |   |                     |
| 32 |              |      |                          |   |                     |
| 33 |              |      |                          |   |                     |
| 34 |              |      |                          |   |                     |
| 35 |              |      |                          |   |                     |
| 36 |              |      |                          |   |                     |
| 37 |              |      |                          |   |                     |
| 39 |              |      |                          |   |                     |
| 41 |              |      |                          |   |                     |
| 42 |              |      |                          |   |                     |
| 43 |              |      |                          |   |                     |

| A-Nr.   | Änderung            | Datum   | Numm | gepr. | Sticht. | Bemerkung |
|---------|---------------------|---------|------|-------|---------|-----------|
| a 10972 | Serie neu           | 1.8.73  | 41   |       |         |           |
| b 13695 | Serie wird gelöscht | 28.6.76 | 74   |       |         |           |

Informationen

VERFAHREN  
DIREKTION

12.6.73

Klein- und Fertigungsdienst  
zurückerbefen  
21. Dez. 1976

Wechselkupplung

Lamellen- und Kupplungsbau  
GmbH  
Bühl/Paderborn

2 025 022 01

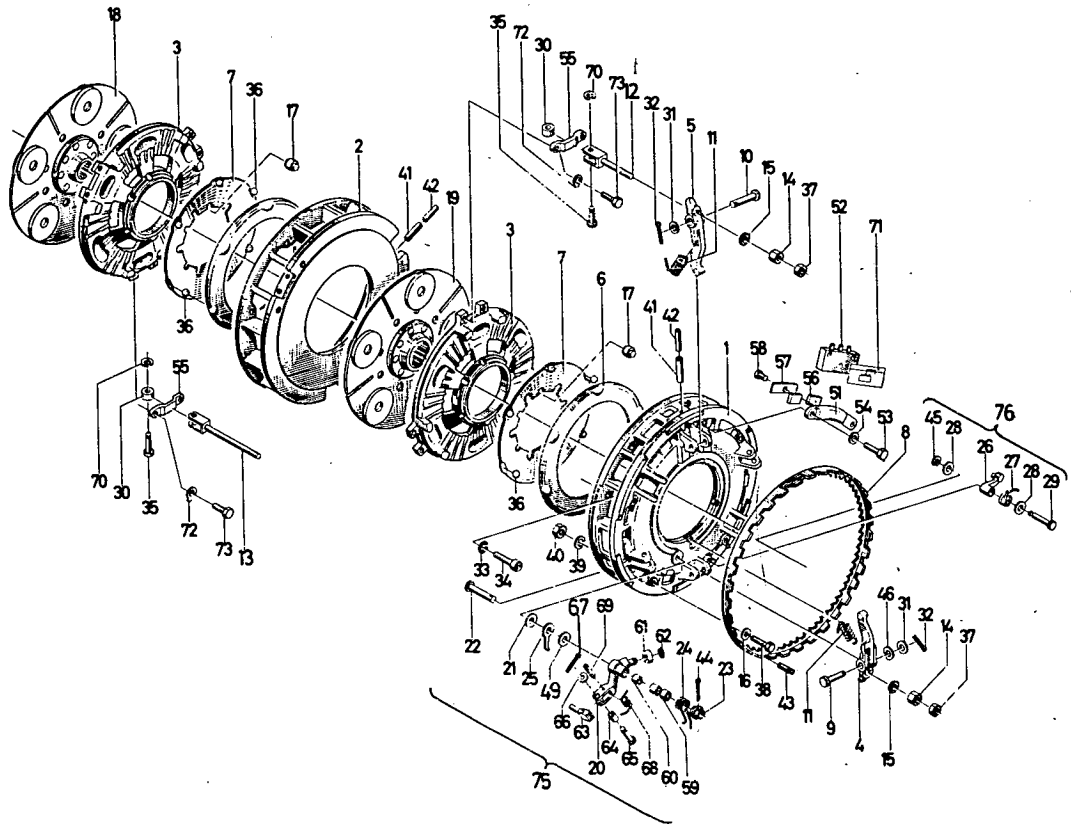

1003-02 501 7148

| Bild Nr. | Teile-Nr. | Stück-Zahl | Deutsch                | English         | Français           | Español            | Nummer/Bemerkung     | ETK |
|----------|-----------|------------|------------------------|-----------------|--------------------|--------------------|----------------------|-----|
| 1        | 237 9610  | 1          | GEHÄUSEOBERTEIL        | HOUSING TOP     | PART .SUP CARTER   | PTE .SUP ER .CAJA  |                      |     |
| 2        | 238 2564  | 1          | GEHÄUSEUNTERTEIL       | HOUSING BASE    | PART .INF CARTER   | PTE .IFER CAJA     |                      |     |
| 3        | 238 2555  | 2          | KUPPL.DRUCKPLATTE      | THRUST PLATE    | PLATEAU D'EMBRAY   | PLACA PRES.EMBRAG. |                      |     |
| 4        | 237 9615  | 1          | HEBEL                  | LEVER/ARM       | LEVIER             | PALANCA            |                      |     |
| 5        | 237 9617  | 5          | HEBEL                  | LEVER/ARM       | LEVIER             | PALANCA            |                      |     |
| 6        | 238 2553  | 2          | STÜTZRING              | SUPPORT RING    | BAQUE DE SUPPORT   | ANILLO APOYO       |                      |     |
| 7        | 238 2554  | 2          | TELLERFEDER            | CUP SPRING      | RESSORT BELLEVILLE | RESORTE DE PLATO   |                      |     |
| 8        | 237 9612  | 1          | SCHALTTRING            | SHIFT RING      | BAQUE COMMANDE     | ANILLO CAMBIO      |                      |     |
| 9        | 237 9614  | 1          | BOLZEN                 | PI N/BOLT/STUD  | BOULON/AXE         | BULON              |                      |     |
| 10       | 237 9618  | 5          | BOLZEN                 | PI N/BOLT/STUD  | BOULON/AXE         | BULON              |                      |     |
| 11       | 237 9619  | 6          | ZUGFEDER               | DRAW SPRING     | RESSORT TRACTION   | RESORTE TRACCION   |                      | 01  |
| 12       | 238 2556  | 2          | AUSRLECKGABEL          | RELEASE FORK    | FOURCHE DE DEBRAY  | FORQUILLA DESEMBR. |                      |     |
| 13       | 238 2565  | 2          | <del>DRUCKPLATTE</del> | THRUST PLATE    | PLAQUE DE BUTEE    | PLACA PRESION      |                      |     |
| 14       | 110 2863  | 6          | SECHSKANTMUTTER        | HEX. NUT        | ECROU 6 PANS       | TUERCA HEXAGONAL   | M8X1 DIN 936-M8G A4C |     |
| 15       | 238 2561  | 6          | SCHEIBE                | DISC/PANE/PLATE | RONCELLE/DISQUE    | CISCO/CRISTAL/PLAT |                      |     |
| 16       | 237 9613  | 4          | SCHEIBE                | DISC/PANE/PLATE | RONCELLE/DISQUE    | CISCO/CRISTAL/PLAT |                      |     |
| 17       | 238 2552  | 6          | BOLZEN                 | PI N/BOLT/STUD  | BOULON/AXE         | BULON              |                      |     |
| 18       | 238 2566  | 1          | KUPPLUNGSSCHEIBE       | DISC            | DISQUE D'EMBRAYAGE | PLATO EMBRAGUE     |                      | 01  |
| 19       | 238 2563  | 1          | KUPPLUNGSSCHEIBE       | DISC            | DISQUE D'EMBRAYAGE | PLATO EMBRAGUE     |                      | 01  |
| 20       | 238 1667  | 1          | HEBEL                  | LEVER/ARM       | LEVIER             | PALANCA            |                      |     |
| 21       | 238 2446  | 1          | SCHEIBE                | DISC/PANE/PLATE | RONCELLE/DISQUE    | CISCO/CRISTAL/PLAT |                      |     |
| 22       | 238 1697  | 1          | BOLZEN                 | PI N/BOLT/STUD  | BOULON/AXE         | BULON              |                      |     |
| 23       | 238 2448  | 1          | BUNDSCHLEIBE           | COLLAR WASHER   | DISQUE A COLLET    | ARANDELA COLLARIN  |                      |     |
| 24       | 238 2447  | 1          | SCHENKELFEDER          | YOKE SPRING     | RESSORT BRANCHES   | RESORTE PATILLA    |                      |     |
| 25       | 238 1699  | 1          | SICHERUNGSELECH        | LOCKING PLATE   | TOLE DE SECURITE   | CHAPA SEGURIDAD    |                      |     |
| 26       | 238 2449  | 1          | SPERRHEBEL             | LOCKING LEVER   | LEVIER DE BLOCAGE  | PALANCA BLOQUEE    |                      |     |



| Bld Nr. | Teile-Nr. | Stück-Zahl | Deutsch           | English           | Français            | Español             | Nummer/Bemerkung                              | ETK |
|---------|-----------|------------|-------------------|-------------------|---------------------|---------------------|---|-----|
| 27      | 238 2442  | 1          | SCHENKELFEJER     | YOKER SPRING      | RESSORT BRANCHES    | RESORTE PATILLA     |   |     |
| 28      | 238 2550  | 2          | SCHEIBE           | DISC/PANE/PLATE   | RONDELLE/CISQUE     | DISCO/CRISTAL/PLAT  |   |     |
| 29      | 238 2551  | 1          | BOLZEN            | PIN/BOLT/STUD     | BOULON/AXE          | BULON               |   |     |
| 30      | 238 2558  | 6          | ROLLE             | ROLLER            | ROULEAU/GALET       | RODILLO/POLEA       |   |     |
| 31      | 110 7548  | 11         | SCHEIBE           | DISC/PANE/PLATE   | RONDELLE/CISQUE     | DISCO/CRISTAL/PLAT  | 8,40 IN 433-ST-A4C                            |     |
| 32      | 110 6428  | 11         | SPLINT            | SPLIT PIN         | GOUVILLE FENDUE     | PASADOR ALETAS      | 3 X 15 DIN 94 VZKC                            |     |
| 33      | 110 2759  | 6          | FEDERRING         | SPRING LOCKWASHER | RONDELLE CROMER     | ARANDELA ELASTICA   | A 8 DIN 128 A4C                               |     |
| 34      | 111 0577  | 6          | ZYLINDER SCHRAUBE | CHEESE-HEAD SCREW | VIS TETE CYLINDR.   | TORN.CBZA.CILIND.   | M 8 X 25 DIN 912- 8.8 A4C                     |     |
| 35      | 238 2559  | 6          | BOLZEN            | PIN/BOLT/STUD     | BOULON/AXE          | BULON               |   |     |
| 36      | 111 6962  | 12         | KUGEL             | BALL              | BILLE/BOULE         | BOLA                | 12 MM III DIN 5401                            |     |
| 37      | 238 2562  | 6          | SECHSKANTMUTTER   | HEX. NUT          | ECROU 6 PANS        | TUERCA HEXAGONAL    |   |     |
| 38      | 112 3749  | 3          | SECHSKANTSCHRAUBE | HEX. BOLT         | VIS 6 PANS          | TORNILLO HEXAGONAL  | M6X25 DIN 933-8.8-A4C                         |     |
| 39      | 110 2797  | 5          | FEDERRING         | SPRING LOCKWASHER | RONDELLE CROMER     | ARANDELA ELASTICA   | A 6 DIN 128 A4C                               |     |
| 40      | 111 2813  | 5          | SECHSKANTMUTTER   | HEX. NUT          | ECROU 6 PANS        | TUERCA HEXAGONAL    | M 6 DIN 534-M8-A4C                            |     |
| 41      | 111 5471  | 12         | SPANNHUELSE       | DOWEL SLEEVE      | DOUILLE SERRAGE     | CASQUILLO FIADOR    | 8X28 DIN 1481                                 |     |
| 42      | 111 5442  | 12         | SPANNHUELSE       | DOWEL SLEEVE      | DOUILLE SERRAGE     | CASQUILLO FIADOR    | 5 X 36 DIN 1481                               |     |
| 43      | 237 9611  | 6          | SCHAFTSCHRAUBE    | HEADLESS SCREW    | VIS SANS TETE       | TORN.VASTAGO        |   |     |
| 44      | 110 6422  | 1          | SPLINT            | SPLIT PIN         | GOUVILLE FENDUE     | PASADOR ALETAS      | 3X20 DIN 94-A4C                               |     |
| 45      | 110 7711  | 1          | SICHERUNGSRING    | CIRCLIP           | CIRCLIP             | CIRCLIP             | 6X0,7 DIN 471                                 |     |
| 46      | 110 7283  | 1          | FEDERSCHEIBE      | SPRING WASHER     | RONDELLE ELASTIQUE  | ARANDELA ELASTICA   | 8 8 DIN 137 VZKC                              |     |
| 49      | 238 1658  | 1          | SCHEIBE           | DISC/PANE/PLATE   | RONDELLE/CISQUE     | DISCO/CRISTAL/PLAT  |   |     |
| 51      | 237 6467  | 1          | HALTER            | RETAINER          | SUPPORT/PORT EQUIIL | SOPORTE             |   |     |
| 52      | 238 2567  | 1          | RELAYS            | RELAY             | RELAIS              | RELAIS              |   |     |
| 53      | 112 2389  | 2          | SECHSKANTSCHRAUBE | HEX. BOLT         | VIS 6 PANS          | TORNILLO HEXAGONAL  | M 6 X 35 DIN 931-M 8.8 A4C                    |     |
| 54      | 112 4654  | 2          | SCHEIBE           | DISC/PANE/PLATE   | RONDELLE/CISQUE     | DISCO/CRISTAL/PLAT  | 6,4 DIN 433 A4C                               |     |
| 55      | 238 2557  | 6          | RIEGEL            | LATCH/CATCH       | VERROU              | CERROJO             |   |     |
| 56      | 237 6468  | 2          | MAGNET            | MAGNET/SOLENOID   | AIMANT/ELECTROAIM.  | MAGNETO/ELECTROIMA  |   |     |
| 57      | 237 6469  | 1          | ABDECKBLECH       | COVER PLATE       | TOLE RECOUVREMENT   | CHAPA RECUBRIMIENTO |   |     |
| 58      | 112 6430  | 1          | ZYLINDER SCHRAUBE | CHEESE-HEAD SCREW | VIS TETE CYLINDR.   | TORN.CBZA.CILIND.   | AM 3 X 80 IN 84- 4.8 VZKC                     |     |
| 59      | 117 2105  | 2          | NADELHUELSE       | NEEDLE SLEEVE     | DOUILLE AIGUILLES   | CASQ AGUJA          | HK 9X13X10 H4455                              |     |
| 60      | 238 1689  | 12         | BUCHSE            | BUSH              | DOUILLE             | CASQUILLO           |   |     |
| 61      | 238 1692  | 1          | ROLLE             | ROLLER            | ROULEAU/GALET       | RODILLO/POLEA       |   |     |
| 62      | 110 7713  | 1          | SICHERUNGSRING    | CIRCLIP           | CIRCLIP             | CIRCLIP             | 8X0,8 DIN 471                                 |     |
| 63      | 238 1693  | 1          | KLINKE            | RATCHET/PAWL      | LOQUET/PCIGNEE      | TRINQUETE/MANILLA   |   |     |
| 64      | 238 1694  | 1          | BUCHSE            | BUSH              | DOUILLE             | CASQUILLO           |   |     |
| 65      | 238 1695  | 1          | BOLZEN            | PIN/BOLT/STUD     | BOULON/AXE          | BULON               |   |     |
| 66      | 110 7089  | 1          | SCHEIBE           | DISC/PANE/PLATE   | RONDELLE/CISQUE     | DISCO/CRISTAL/PLAT  | A 5,30 IN 125-ST-A4C                          |     |
| 67      | 110 6389  | 1          | SPLINT            | SPLIT PIN         | GOUVILLE FENDUE     | PASADOR ALETAS      | 1,5X 10 DIN 94-A4C                            |     |
| 68      | 238 1696  | 1          | SCHENKELFEJER     | YOKER SPRING      | RESSORT BRANCHES    | RESORTE PATILLA     |   |     |
| 69      | 111 5417  | 1          | SPANNHUELSE       | DOWEL SLEEVE      | DOUILLE SERRAGE     | CASQUILLO FIADOR    | 4 X 16 DIN 1481                               |     |
| 70      | 111 7927  | 6          | SICHERUNGSSCHEIBE | LOCKING WASHER    | RONDELLE SECURITE   | ARANDELA SEGURIDAD  | 4 DIN 6799                                    |     |
| 71      | 238 2568  | 1          | SCHALTBILD        | SHIFTING GRAPHIC  | SCHEMA CONNEXIONS   | ESQUEMA CONEXIONES  |   |     |
| 72      | 238 2560  | 12         | SICHERUNGSBLECH   | LOCKING PLATE     | TOLE DE SECURITE    | CHAPA SEGURIDAD     |   |     |
| 73      | 111 2307  | 12         | SECHSKANTSCHRAUBE | HEX. BOLT         | VIS 6 PANS          | TORNILLO HEXAGONAL  | M8X16 DIN 533-8.8-A4C                         |     |
| 75      | 238 5124  | 1          | REPARATURSATZ     | REPAIR KIT        | LOT DE REPARATION   | LOTE REPARACIONES   | B 050,BESTEHEND AUS POS.<br>20-25,44,49,59-69 |     |
| 76      | 238 5125  | 1          | REPARATURSATZ     | REPAIR KIT        | LOT DE REPARATION   | LOTE REPARACIONES   | B 050,BESTEHEND AUS POS.<br>26-29,45          |     |

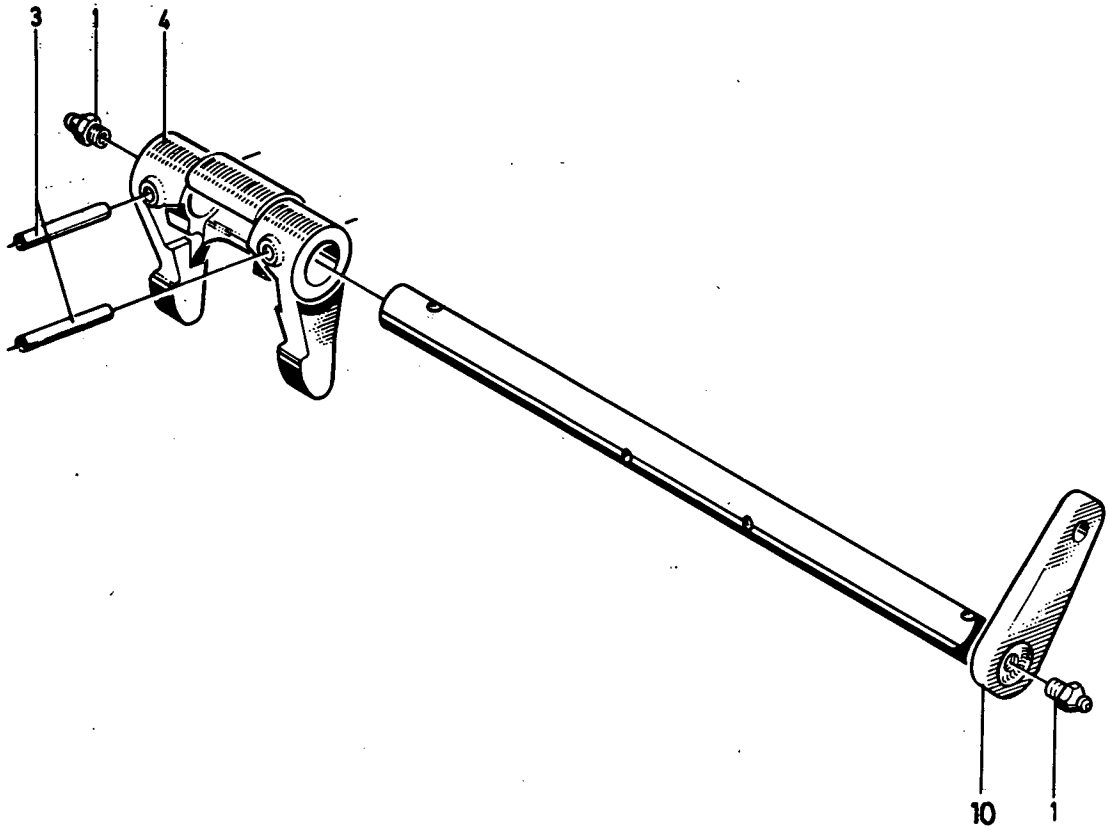

1003-03 501 7010

| Bild Nr. | Teile-Nr. | Stück-Zahl | Deutsch             | English      | Français          | Español           | Nummer/Bemerkung | ETK |
|----------|-----------|------------|---------------------|--------------|-------------------|-------------------|------------------|-----|
| 1        | 116 8224  | 2          | KEGEL SCHMIERNIPPEL | LUBE FITTING | GRAISSEUR CONIQUE | ENGRASADOR CONICO | SA 6H 3360       |     |
| 3        | 111 5461  | 2          | SPANNHUELSE         | DOWEL SLEEVE | DOUILLE SERRAGE   | CASQUILLO FIADOR  | 6X50 DIN 1481    |     |
| 4        | 232 9752  | 1          | GABELHEBEL          | FORKED LEVER | LEVIER A CHAPE    | PALANCA HORQUILLA |                  |     |
| 10       | 238 1948  | 1          | KUPPLUNGSWELLE      | SHAFT        | ARBRE D'EMBRAYAGE | EJE EMBRAGUE      |                  |     |

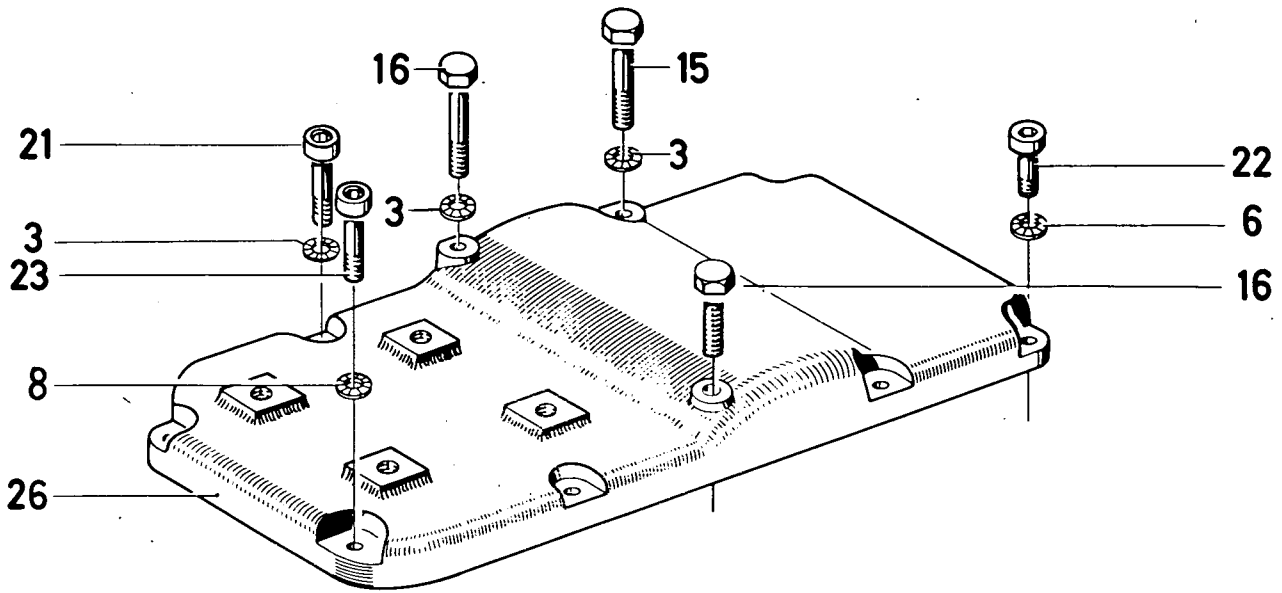

5015787

| Bild<br>Nr. | Teile-Nr. | Stück-<br>Zahl | Deutsch           | English           | Français          | Español            | 1445-08 501 5787           |     |
|-------------|-----------|----------------|-------------------|-------------------|-------------------|--------------------|----------------------------|-----|
|             |           |                |                   |                   |                   |                    | Nummer/Bemerkung           | ETK |
| 3           | 116 9694  | 6              | SICHERUNGSSCHEIBE | LOCKING WASHER    | RONDELLE SECURITE | ARANDELA SEGURIDAD | 10H 2203                   |     |
| 6           | 116 9696  | 2              | SICHERUNGSSCHEIBE | LOCKING WASHER    | RONDELLE SECURITE | ARANDELA SEGURIDAD | 14H 2203                   |     |
| 8           | 116 9695  | 2              | SICHERUNGSSCHEIBE | LOCKING WASHER    | RONDELLE SECURITE | ARANDELA SEGURIDAD | 12H 2203                   |     |
| 15          | 111 2451  | 2              | SECHSKANTSCHRAUBE | HEX. BOLT         | VIS 6 PANS        | TORNILLO HEXAGONAL | M10X45 DIN 933-8.8-A4C     |     |
| 16          | 111 2461  | 2              | SECHSKANTSCHRAUBE | HEX. BOLT         | VIS 6 PANS        | TORNILLO HEXAGONAL | M 10X55 DIN 933-8.8-A4C    |     |
| 21          | 112 2361  | 2              | ZYLINDERSCHRAUBE  | CHEESE-HEAD SCREW | VIS TETE CYLINDR. | TORN.CBZA.CILIND.  | M10X30 DIN 912-8.8 A4C     |     |
| 22          | 111 0805  | 2              | ZYLINDERSCHRAUBE  | CHEESE-HEAD SCREW | VIS TETE CYLINDR. | TORN.CBZA.CILIND.  | M 14X30 DIN 912-6.9 PHOSPH |     |
| 23          | 111 0756  | 2              | ZYLINDERSCHRAUBE  | CHEESE-HEAD SCREW | VIS TETE CYLINDR. | TORN.CBZA.CILIND.  | M12X35 DIN 912-6G          |     |
| 26          | 232 9617  | 1              | GEHAUSEDECKEL     | HOUSING COVER     | COUV DE CARTER    | TAPA CAJA          |                            |     |

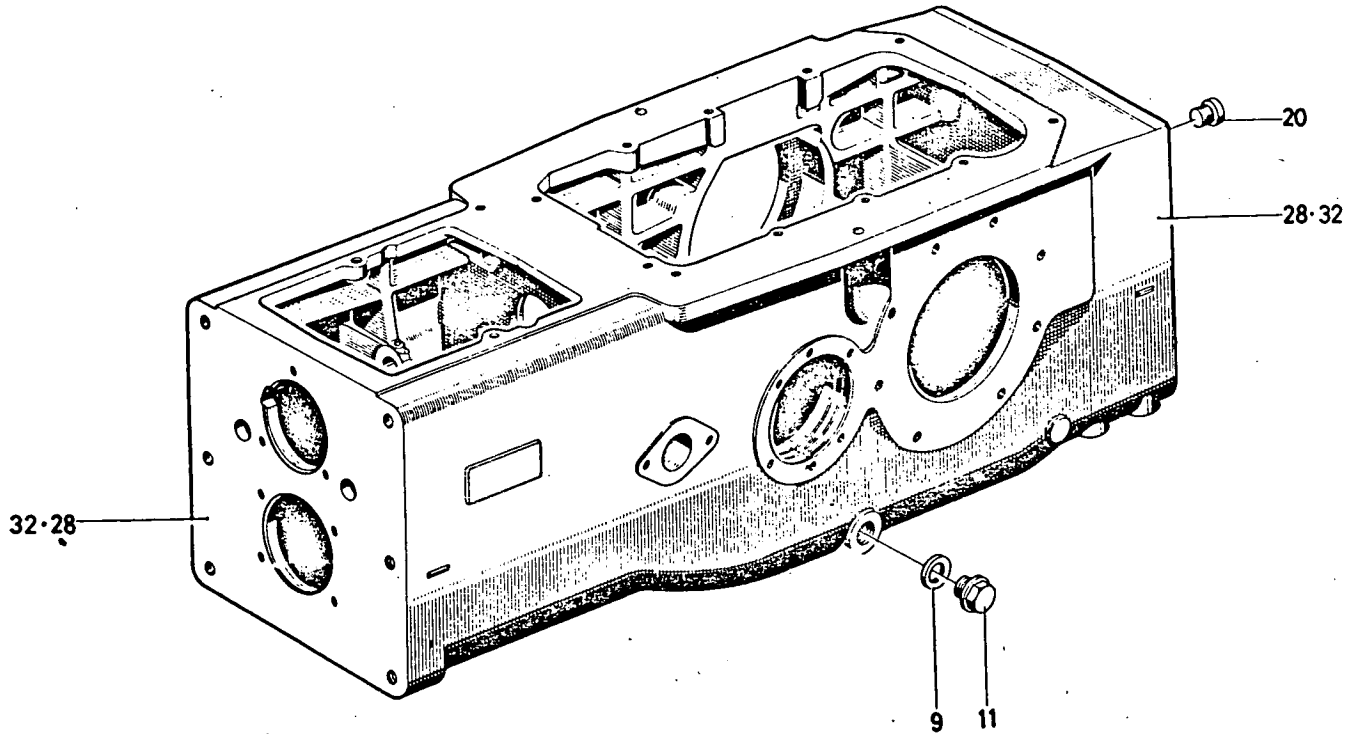

| Bild Nr. | Teile-Nr. | Stück-Zahl | Deutsch            | English           | Français           | Español         | Trummer/Bemer-ung  | ETK |
|----------|-----------|------------|--------------------|-------------------|--------------------|-----------------|--|-----|
| 9        | 111 8737  | 1          | DICHTRING          | WASHER            | BAGUE D'ÉTANCHEITE | ANILLO DE JUNTA | A 22 X 27 DIN 7603-CU                                    |     |
| 11       | 111 8979  | 1          | VERSCHLUSSSCHRAUBE | SCREW PLUG        | BOUCHON FILETE     | TAPON ROSCADO   | AM22X1,5 DIN 7604  | 01  |
| 20       | 116 7325  | 1          | VERSCHLUSSSTOPFEN  | NIPPLE            | BOUCHON            | TAPON OBTURADOR | A 21 H 2873  |     |
| 28       | 237 8910  | 1          | GETRIEBEGEHÄUSE    | TRANSMISSION CASE | CARTER DE BOITE V  | CAJA ENGRANAJE  | 8027,815 FAHRGESTELL-NO<br>8004 AB FAHRGESTELL-NO.POS.32 |     |
| 32       | 238 2680  | 1          | GETRIEBEGEHÄUSE    | TRANSMISSION CASE | CARTER DE BOITE V  | CAJA ENGRANAJE  |  |     |



Getriebegehäuse (Allrad) TW 50.3  
 Transmission Case - Four Wheel Drive TW 50.3  
 Carter de transmission - toutes roues motrices TW 50.3  
 Caja de la transmisión - tracción en las 4 ruedas TW 50.3

1210 - 08 501 5815

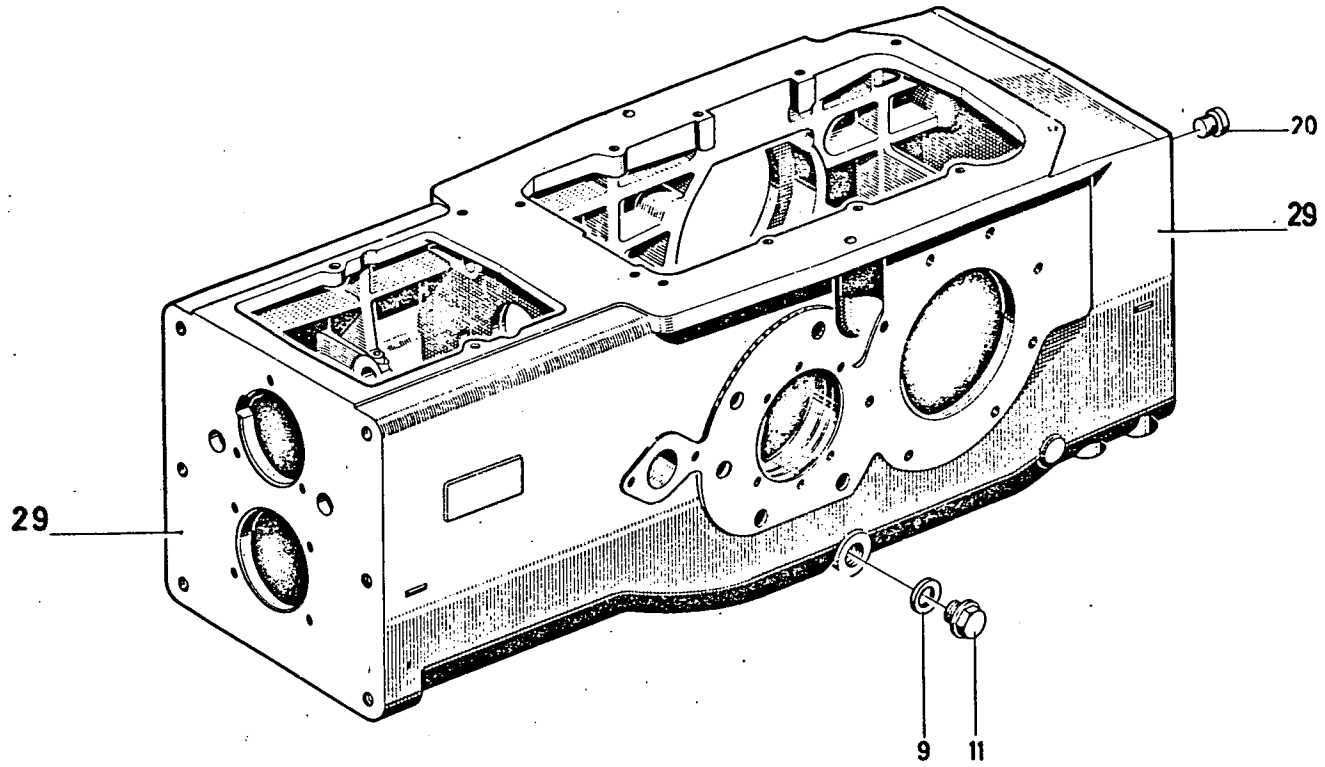

| Bild-Nr. | Teile-Nr. | Stück-Zahl | Deutsch            | English           | Français           | Español         | Nummer/Bemerkung      | ETK |
|----------|-----------|------------|--------------------|-------------------|--------------------|-----------------|-----------------------|-----|
| 9        | 111 8737  | 1          | DICHTRING          | WASHER            | BAGUE D'ETANCHEITE | ANILLO DE JUNTA | A 22 X 27 DIN 7603-CU |     |
| 11       | 111 8979  | 1          | VERSCHLUSSSCHRAUBE | SCREW PLUG        | BOUCHON FILETE     | TAPON ROSCADO   | AM22X1,5 DIN 7604     | 01  |
| 20       | 116 7325  | 1          | VERSCHLUSSSTOPFEN  | NIPPLE            | BOUCHON            | TAPON OBTURADOR | A 21 H 2873           |     |
| 29       | 237 8913  | 1          | GETRIEBEGEHAUSE    | TRANSMISSION CASE | CARTER DE BDITE V  | CAJA ENGRANAJE  |                       |     |

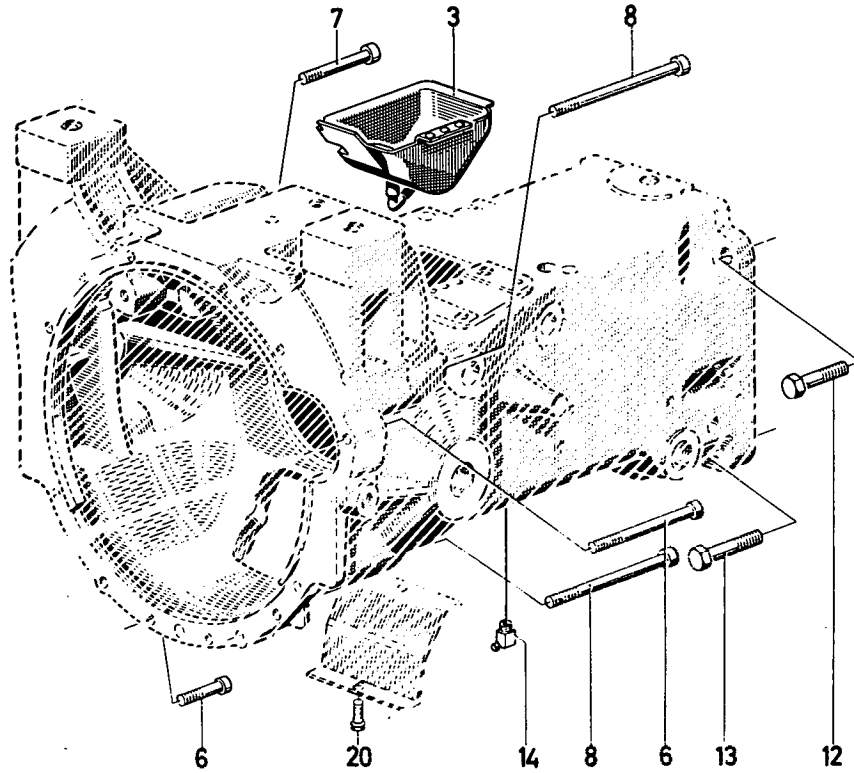

1001-09 501 5788

| Bild Nr. | Teile-Nr. | Stück-Zahl | Deutsch            | English           | Français          | Español            | Nummer/Bemerkung              | ETK |
|----------|-----------|------------|--------------------|-------------------|-------------------|--------------------|-------------------------------|-----|
| 3        | 230 8112  | 1          | HAUBE              | HOOD              | CAPOT/BONNET      | CAPERUZA/CAPOT     |                               |     |
| 6        | 112 2363  | 4          | ZYLINDERSCHRAUBE   | CHEESE-HEAD SCREW | VIS TETE CYLINDR. | TORN.CBZA.CILIND.  | M10X 70DIN 912- 8.8 A4C       |     |
| 7        | 111 0712  | 4          | ZYLINDERSCHRAUBE   | CHEESE-HEAD SCREW | VIS TETE CYLINDR. | TORN.CBZA.CILIND.  | M10X 90DIN 912- 8.8 A4C       |     |
| 8        | 111 0734  | 3          | ZYLINDERSCHRAUBE   | CHEESE-HEAD SCREW | VIS TETE CYLINDR. | TORN.CBZA.CILIND.  | M10X 160DIN 912- 8.8-A4C      |     |
| 12       | 110 1145  | 4          | SECHSKANTSCHRAUBE  | HEX.BOLT          | VIS 6 PANS        | TORNILLO HEXAGONAL | M18X2 X 50 DIN 960-M 8.8-A4C  |     |
| 13       | 112 3784  | 2          | SECHSKANTSCHRAUBE  | HEX.BOLT          | VIS 6 PANS        | TORNILLO HEXAGONAL | M18X2 X 60 DIN 960-M 8.8 VZKC |     |
| 14       | 116 8227  | 1 2        | KEGELSCHMIERNIPPEL | LUBE FITTING      | GRAISSEUR CONIQUE | ENGRASADOR CONICO  | SB 8H 3360                    |     |
| 20       | 111 2232  | 1 2        | SECHSKANTSCHRAUBE  | HEX.BOLT          | VIS 6 PANS        | TORNILLO HEXAGONAL | M 6X 10 DIN 933- 8.8-A4C      |     |

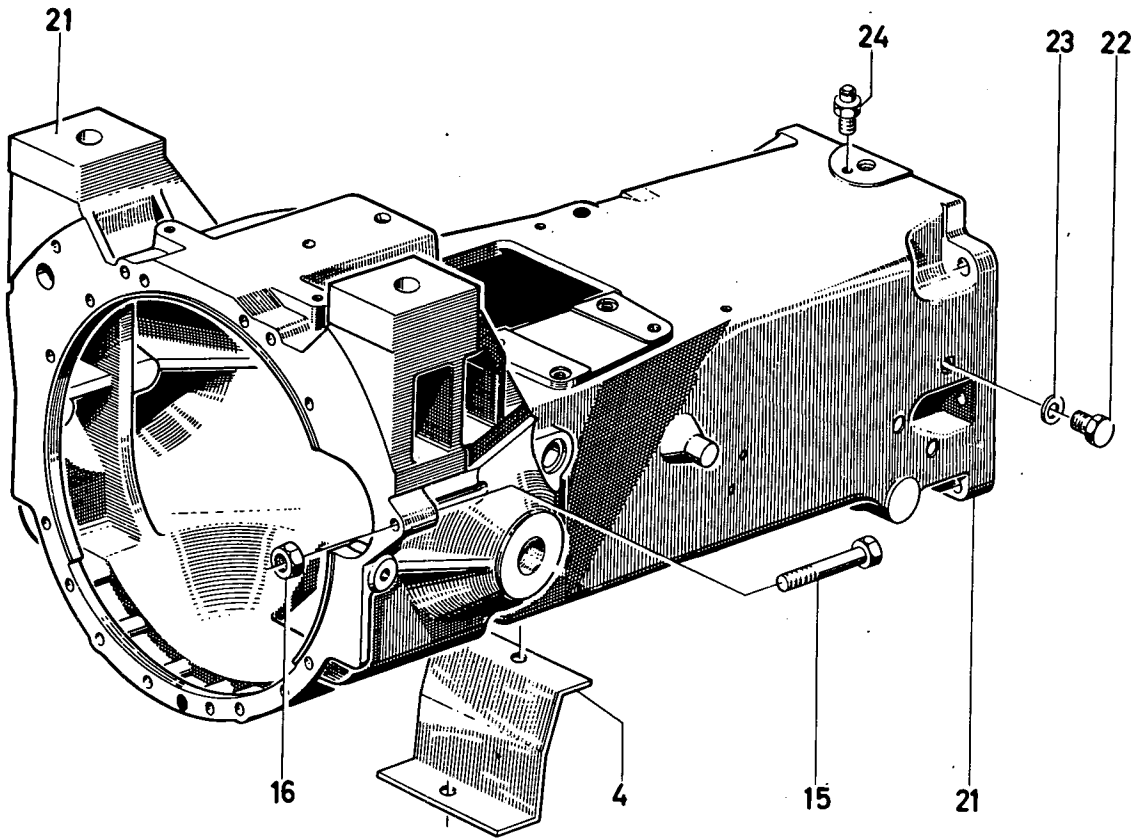

1001-09 501 5789

| Bild Nr. | Teile-Nr. | Stück-Zahl | Deutsch            | English         | Français              | Español            | Nummer/Bemerkung         | ETK |
|----------|-----------|------------|--------------------|-----------------|-----------------------|--------------------|--------------------------|-----|
| 4        | 338 9276  | 1          | HANDLOCHDECKEL     | HAND HOLE COVER | COUVERCLE VISITE      | TAPA ORIF.ACCESO   | 1145-09-01.02            |     |
| 15       | 111 2476  | 1          | SECHSKANTSCHRAUBE  | HEX.BOLT        | VIS 6 PANS            | TORNILLO HEXAGONAL | M10X 90 DIN 933- 8.8-A4C |     |
| 16       | 111 2841  | 1          | SECHSKANTMUTTER    | HEX.NUT         | ECROU 6 PANS          | TUERCA HEXAGONAL   | M10 DIN 934-M 8          |     |
| 21       | 233 3951  | 1          | KUPPLUNGSGEHAUSE   | CLUTCH HOUSING  | CARTER D'EMBRAYAGE    | CAJA EMBRAGUE      |                          |     |
| 22       | 111 8980  | 2          | VERSCHLUSSSCHRAUBE | SCREW PLUG      | BOUCHON FILETE        | TAPON ROSCADO      | M22X1,5 DIN 7604 VZKC    |     |
| 23       | 111 8737  | 2          | DICHTRING          | WASHER          | BAGUE D'ETANCHEITE    | ANILLO DE JUNTA    | A 22 X 27 DIN 7603-CU    |     |
| 24       | 230 3612  | 1          | ENTLUEFTUNGSVENTIL | BREATHER VALVE  | SOUP DEGAGEMENT D'AIR | VALV.PRGA.AIRE     |                          |     |



Zwischengetriebe  
Intermediate-Gear Box  
Bolte à Vitesses-intermédiaire  
Caja de cambios de velocid.-intermedia

1446-09 501 5800

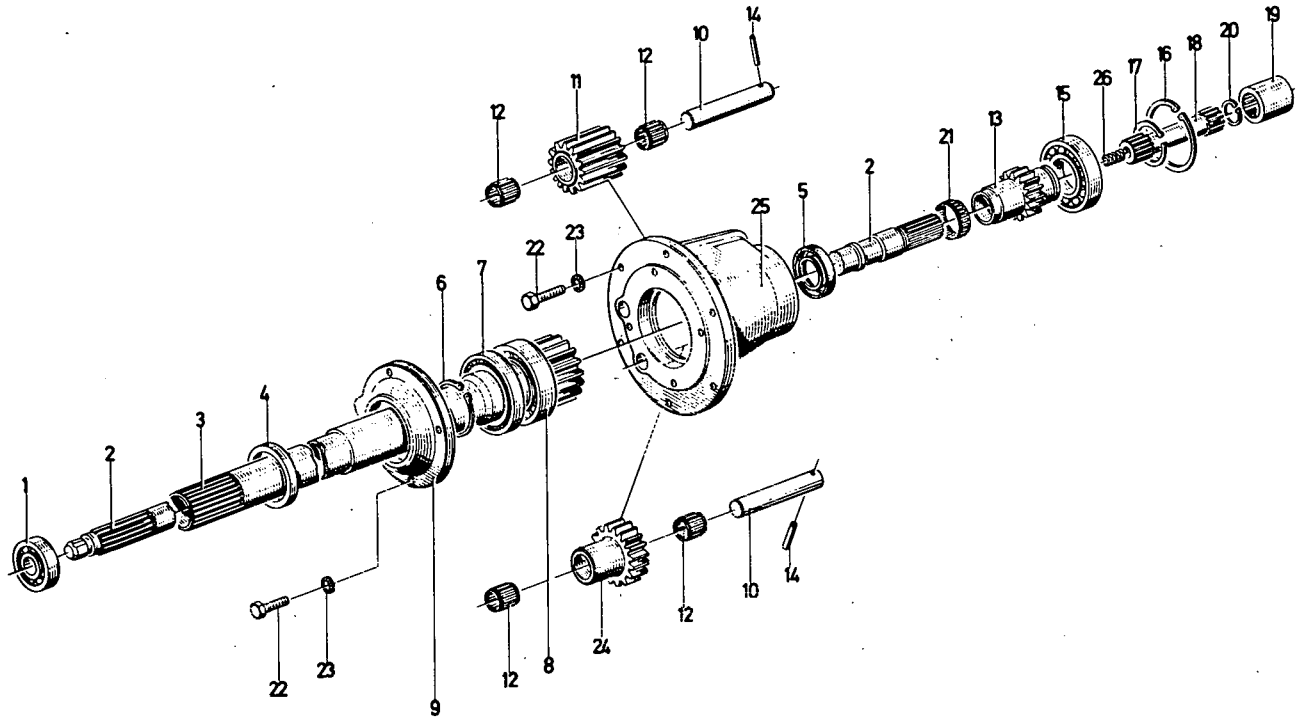

| Bld Nr. | Teile-Nr. | Stück-Zahl | Deutsch           | English            | Français           | Español            | 1446-09 501 5800<br>Nummer/Bemerkung | ETK |
|---------|-----------|------------|-------------------|--------------------|--------------------|--------------------|--------------------------------------|-----|
| 1       | 110 9118  | 1          | RILLENKUGELLAGER  | BALL BEARING       | ROUL RAINURE BILLE | COJ.BOLAS FIJO     | 6304-2RS DIN 625                     | 01  |
| 2       | 233 3430  | 1          | ANTRIEBSWELLE     | DRIVE SHAFT        | ARBRE DE COMMANDE  | EJE MOTRIZ         |                                      |     |
| 3       | 232 9739  | 1          | ANTRIEBSHOHLWELLE | DRIVE GULL         | ARBRE CREUX        | EJE MOTRIZ HUECO   |                                      |     |
| 4       | 116 0685  | 1          | WELLENDICHRING    | SHAFT SEAL         | JOINT D'ARBRE      | ANILLO HERMET.EJE  | A 55X 70 X 8 H 2940-NI               | 01  |
| 5       | 116 7496  | 1          | WELLENDICHRING    | SHAFT SEAL         | JOINT D'ARBRE      | ANILLO HERMET.EJE  | A 30X 40 X 7 H 2940-NI               | 01  |
| 6       | 110 7770  | 1          | SICHERUNGSRING    | CIRCLIP            | CIRCLIP            | CIRCLIP            | 55X2 DIN 471                         |     |
| 7       | 110 9184  | 1          | RILLENKUGELLAGER  | BALL BEARING       | ROUL RAINURE BILLE | COJ.BOLAS FIJO     | 16011 DIN 625                        | 01  |
| 8       | 110 4340  | 1          | ZYL.-ROLLENLAGER  | PAR.ROLL.BEARING   | ROULEM.ROUL.CYL.   | COJ.RODILL.CILINDR | NU1011 DIN 5412                      | 01  |
| 9       | 233 3941  | 1          | DECKEL            | COVER              | COUVERCLE          | TAPA               |                                      |     |
| 10      | 233 3943  | 2          | LAGERBOLZEN       | PIVOT PIN          | AXE SUPPORT        | BILON SOPORTE      |                                      |     |
| 11      | 232 9741  | 1          | ZAHNRAD           | GEAR               | ROUE DENTEE        | RUEGA DENTADA      | Z=15                                 |     |
| 12      | 116 4045  | 4          | NADELKAEFIG       | NEEDLE GAGE        | CAGE A AIGUILLES   | JAULA AGUJAS       | K20X26X25 H 4455                     | 01  |
| 13      | 232 9745  | 1          | ABTRIEBSRAD       | OUTPUT GEAR        | ENGRENAGE MENE     | RUEGA TOMA FUERZA  | Z=15                                 |     |
| 14      | 111 5457  | 2          | SPANNHUELSE       | DOWEL SLEEVE       | DOUILLE SERRAGE    | CASQUILLO FIADOR   | 6 X 36DIN 1481 VZAC                  |     |
| 15      | 110 9062  | 1          | RILLENKUGELLAGER  | BALL BEARING       | ROUL RAINURE BILLE | COJ.BOLAS FIJO     | 6208 DIN 625                         | 01  |
| 16      | 110 7855  | 1          | SICHERUNGSRING    | CIRCLIP            | CIRCLIP            | CIRCLIP            | 80X2,5 DIN 472                       |     |
| 17      | 110 7755  | 1          | SICHERUNGSRING    | CIRCLIP            | CIRCLIP            | CIRCLIP            | 40X1,75DIN 471                       |     |
| 18      | 233 3944  | 1          | ANTRIEBSWELLE     | DRIVE SHAFT        | ARBRE DE COMMANDE  | EJE MOTRIZ         |                                      |     |
| 19      | 233 3945  | 1          | VERBINDUNGSTUECK  | CONNECTING PIECE   | RACCORD            | PIEZA UNION        |                                      |     |
| 20      | 110 7814  | 1          | SICHERUNGSRING    | CIRCLIP            | CIRCLIP            | CIRCLIP            | 25X1,2 DIN 472                       |     |
| 21      | 116 4046  | 1          | NADELKAEFIG       | NEEDLE GAGE        | CAGE A AIGUILLES   | JAULA AGUJAS       | K37X42X13 H 4455                     | 01  |
| 22      | 111 2264  | 10         | SECHSKANTSCHRAUBE | HEX.BOLT           | VIS 6 PANS         | TORNILLO HEXAGONAL | M 6X20 DIN 933-8.8-A4C               |     |
| 23      | 116 7194  | 10         | SICHERUNGSSCHEIBE | LOCKING WASHER     | RONDELLE SECURITE  | ARANDELA SEGURIDAD | 6 H 2203                             |     |
| 24      | 232 9743  | 1          | ZWISCHENRAD       | IDLEP GEAR         | ROUE INTERMEDIAIRE | RUEGA INTERMEDIA   | Z=19                                 |     |
| 25      | 233 3946  | 1          | SCHALTGEHAUSE     | HOUSING            | CARTER COMMANDE    | CAJA CAMBIO/MANDO  |                                      |     |
| 26      | 338 6770  | 1          | DRUCKFEDER        | COMPRESSION SPRING | RESSORT DE COMPR   | RESORTE PRESION    | 1055-12-01.33                        | 01  |



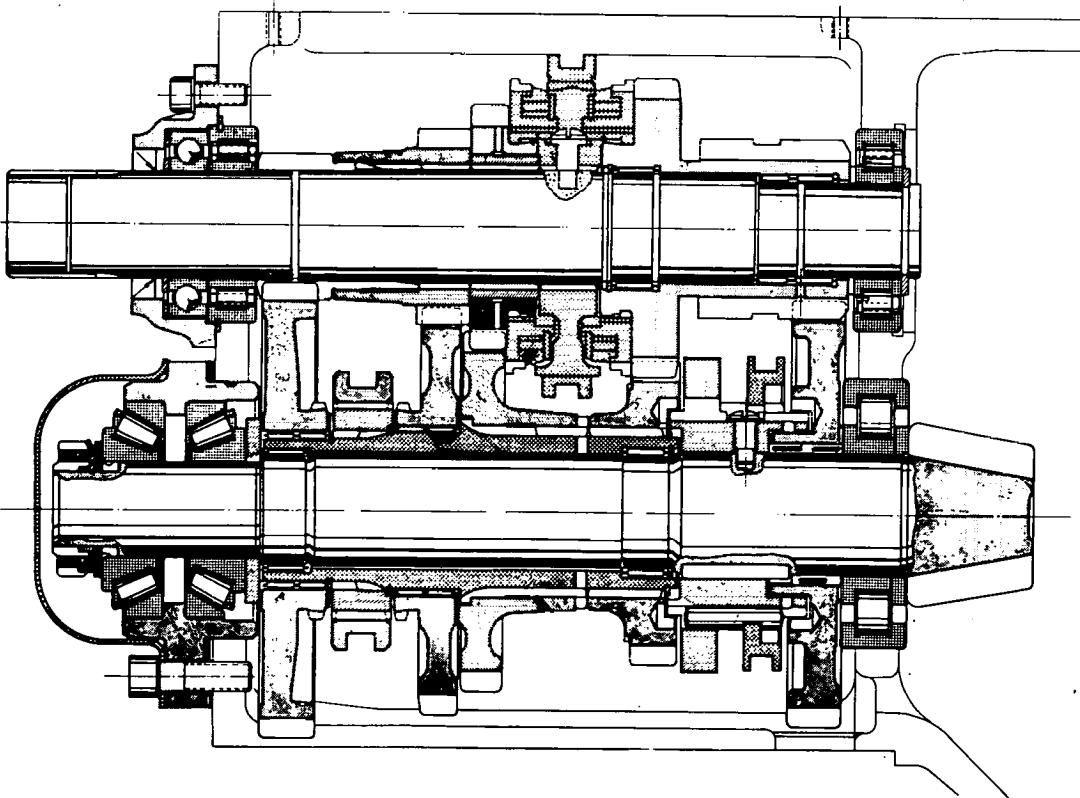
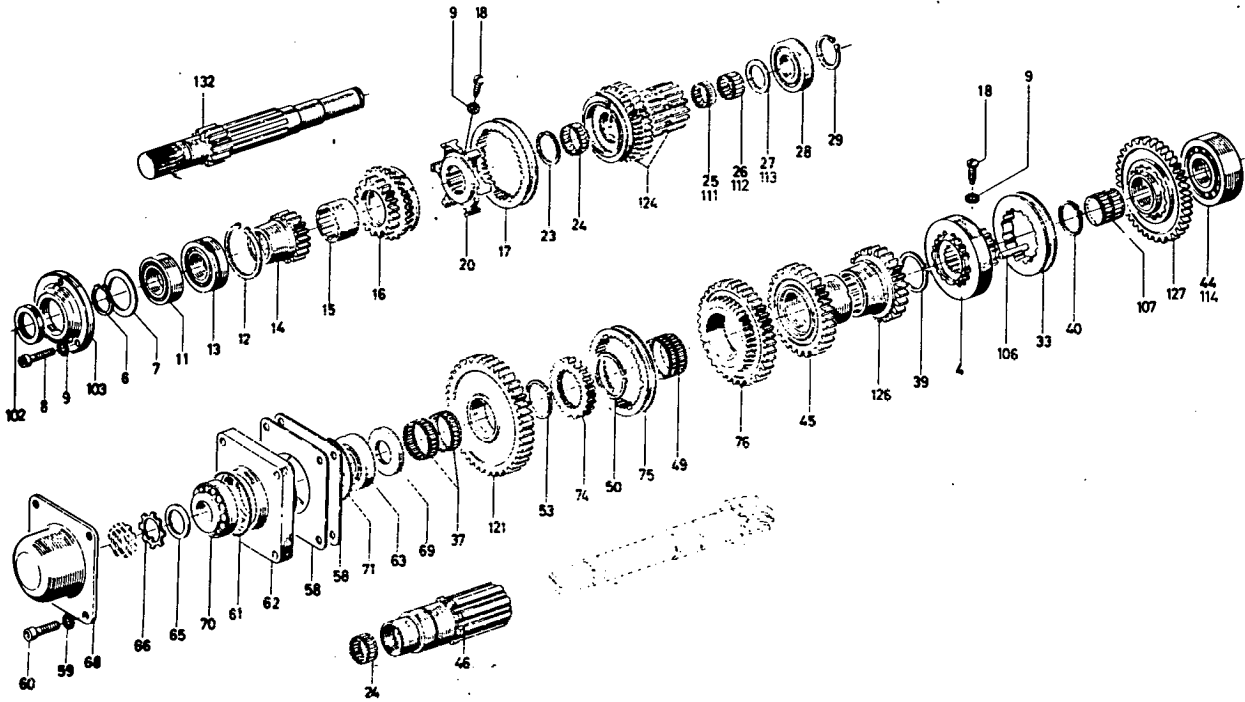

| Bld Nr. | Tele-Nr.            | Stück-Zahl | Deutsch           | Englisch           | Français           | Español            | Nummer/Bemerkung                                   | ETK |
|---------|---------------------|------------|-------------------|--------------------|--------------------|--------------------|--|-----|
| 4       | 233 4684            | 1          | SCHALTRING        | SHIFT RING         | BAGUE COMMANDE     | ANILLO CAMBIO      |  |     |
| 6       | 110 7755            | 1          | SICHERUNGSRING    | CIRCLIP            | CIRCLIP            | CIRCLIP            | 40X1,75DIN 471                                     |     |
| 7       | 230 2055            | SZ         | BEILAGE           | SHIM               | CALE               | SUPLEMENTO         | 8076,EINZELTEILE SIEHE POS. 950-957                |     |
| 8       | 111 0562            | 3          | ZYLINDERSCHRAUBE  | CHEESE-HEAD SCREW  | VIS TETE CYLINDR.  | TORN.CBZA.CILIND.  | M 8X 200IN 912- 6.9                                |     |
| 9       | 116 9689            | 5          | SCHEIBE           | DISC/PANE/PLATE    | RONDELLE/DISQUE    | DISCO/CRISTAL/PLAT | 8H 2203  |     |
| 11      | 110 1409            | 1          | KILLENKUGELLAGER  | BALL BEARING       | ROUL RAINURE BILLE | COJ.BOLAS FIJO     | 6008 C30IN 625                                     | 01  |
| 12      | 111 7455            | 1          | SPRENGRING        | SNAP RING          | AGRAFE CIRCULAIRE  | ANILLO RETENCION   | SP 72DIN 5417                                      |     |
| 13      | 230 1896            | 1          | ZYL.-ROLLENLAGER  | PAR.ROLL.BEARING   | ROULEM.ROUL.CYL.   | COJ.RODILL.CILINDR |  | 01  |
| 14      | 230 2386            | 1          | ZAHNRAD           | GEAR               | ROUE DENTEE        | RUEDA DENTADA      | Z=18   |     |
| 15      | 230 1895            | 1          | BUCHSE            | BUSH               | DOUILLE            | CASQUILLO          |  |     |
| 16      | 230 3570            | 1          | ZAHNRAD           | GEAR               | ROUE DENTEE        | RUEDA DENTADA      |  |     |
| 17      | 230 2353            | 1          | SCHALTMUFFE       | SHIFT SLEEVE       | MANCHON COMMANDE   | MANGUITO CAMBIO    |  |     |
| 18      | 230 3566            | 2          | LINSENSCHRAUBE    | FILL.-HEAD SCREW   | VIS GOUTTE DE SUIF | TORN.CAB.LENTICUL. |  | 01  |
| 20      | 230 2351            | 1          | MUFFE             | SLEEVE             | MANCHON            | MANGUITO           |  |     |
| 23      | 116 0345            | 2          | SPRENGRING        | SNAP RING          | AGRAFE CIRCULAIRE  | ANILLO RETENCION   | 45X1,5 H 2259                                      | 01  |
| 24      | 116 8741            | 3          | NADELKAEFIG       | NEEDLE GAGE        | CAGE A AIGUILLES   | JAULA AGUJAS       | HS 40X45X17 H 4455                                 | 01  |
| 25      | 116 0078            | 1          | NADELKAEFIG       | NEEDLE GAGE        | CAGE A AIGUILLES   | JAULA AGUJAS       | K 35 X 40X13 H 4455<br>8027,BIS FAHRGESTELL-NO.    | 01  |
| 26      | 116 0064            | 1          | NADELKAEFIG       | NEEDLE GAGE        | CAGE A AIGUILLES   | JAULA AGUJAS       | HS 35X40X17 H 4455<br>8027,BIS FAHRGESTELL-NO.     | 01  |
| 27      | 230 2045            | SZ         | BEILAGE           | SHIM               | CALE               | SUPLEMENTO         | 8027,BIS FAHRGESTELL-NO.<br>8285,SIEHE POS.958-967 |     |
| 28      | 230 1897            | 1          | ZYL.-ROLLENLAGER  | PAR.ROLL.BEARING   | ROULEM.ROUL.CYL.   | COJ.RODILL.CILINDR |  | 01  |
| 29      | 110 7749            | 1          | SICHERUNGSRING    | CIRCLIP            | CIRCLIP            | CIRCLIP            | 35X2,5 DIN 471                                     |     |
| 33      | 230 1891            | 1          | SCHALTRING        | SHIFT RING         | BAGUE COMMANDE     | ANILLO CAMBIO      |  |     |
| 37      | 116 0079            | 2          | NADELKAEFIG       | NEEDLE GAGE        | CAGE A AIGUILLES   | JAULA AGUJAS       | HS 52 X 57X12 H 4455                               | 01  |
| 39      | 116 0083            | 1          | SPRENGRING        | SNAP RING          | AGRAFE CIRCULAIRE  | ANILLO RETENCION   | 55X1,5H 2258                                       | 01  |
| 40      | 116 2930            | 1          | SPRENGRING        | SNAP RING          | AGRAFE CIRCULAIRE  | ANILLO RETENCION   | 45X1,5H 2258                                       | 01  |
| 44      | 233 5260            | U 1        | ZYL.-ROLLENLAGER  | PAR.ROLL.BEARING   | ROULEM.ROUL.CYL.   | COJ.RODILL.CILINDR | 8027,BIS FAHRGESTELL-NO.                           | 01  |
| 45      | 230 3440            | 1          | ZAHNRAD           | GEAR               | ROUE DENTEE        | RUEDA DENTADA      | Z=35   |     |
| 46      | <del>233 4971</del> | 1          | HOHLWELLE         | QUILL SHAFT        | ARBRE CREUX        | EJE HUECO          | <del>230 7777</del>                                |     |
| 49      | 116 1602            | 1          | DOPPELNADELKAEFIG | NEEDLE CAGE        | CAGE AIGUILLES     | JAULA AGUJ.2 HIL.  | 25 58 X 62X25 H 4455                               | 01  |
| 50      | 116 0082            | 1          | SPRENGRING        | SNAP RING          | AGRAFE CIRCULAIRE  | ANILLO RETENCION   | 58X1,5H 2258                                       | 01  |
| 53      | 116 0081            | 1          | SPRENGRING        | SNAP RING          | AGRAFE CIRCULAIRE  | ANILLO RETENCION   | 52X1,5H 2258                                       | 01  |
| 58      | 339 1880            | SZ         | BEILAGE           | SHIM               | CALE               | SUPLEMENTO         | 1424-11-02.10<br>8285,SIEHE POS.968-972            |     |
| 59      | 116 9694            | 4          | SICHERUNGSSCHEIBE | LOCKING WASHER     | RONDELLE SECURITE  | ARANDELA SEGURIDAD | 10H 2203   |     |
| 60      | 111 0678            | 4          | ZYLINDERSCHRAUBE  | CHEESE-HEAD SCREW  | VIS TETE CYLINDR.  | TORN.CBZA.CILIND.  | M10X 450IN 912-10.9                                |     |
| 61      | 116 6126            | 1          | RUNDGUMMRING      | O-SEAL             | ANNEAU TORIQUE     | ANILLO GOMA REDOND | 95 X 3 H 721                                       | 01  |
| 62      | 231 6155            | 1          | LAGERFLANSCH      | BEARING FLANGE     | BRIDE SUPPORT      | BRIDA SOPORTE      |  |     |
| 63      | <del>233 3422</del> | 1          | KEGELROLLENLAGER  | TAP.ROLLER BEARING | ROULEM A ROUL CON  | COJ.RODIL.CONICOS  | 230 6668   | 01  |
| 65      | 339 2442            | 1          | NASENSCHEIBE      | TAB WASHER         | RONDELLE A TALON   | ARANDELA RESALTO   | 1445-11-01.46                                      | 01  |
| 66      | 121 6057            | 1          | SICHERUNGSBLECH   | LOCKING PLATE      | TOLE DE SECURITE   | CHAPA SEGURIDAD    | 2 251 B 35   | 01  |
| 68      | 339 2443            | 1          | DECKEL            | COVER              | COUVERCLE          | TAPA               | 1445-11-01.49                                      |     |
| 69      | 230 7571            | 1          | ANLAUFSCHLEIBE    | STOP WASHER        | DISQUE BUTEE       | ARANDELA TOPE      |  | 01  |
| 70      | 110 9990            | 1          | KEGELROLLENLAGER  | TAP.ROLLER BEARING | ROULEM A ROUL CON  | COJ.RODIL.CONICOS  | 31307 DIN 720                                      | 01  |
| 71      | 116 6121            | 1          | RUNDGUMMRING      | O-SEAL             | ANNEAU TORIQUE     | ANILLO GOMA REDOND | 90 X 2 H 721                                       | 01  |
| 74      | 230 7795            | 1          | MUFFENTRAEGER     | SOCKET CARRIER     | PORTE-MANCHON      | PORTAMANGUITO      |  |     |
| 75      | 230 3561            | 1          | SCHALTMUFFE       | SHIFT SLEEVE       | MANCHON COMMANDE   | MANGUITO CAMBIO    |  |     |
| 76      | 230 7796            | 16         | ZAHNRAD           | GEAR               | ROUE DENTEE        | RUEDA DENTADA      | Z=40   |     |

x Verb: *axis für hohlschelle 233 3423*  
*231 6795*

| Bld<br>Nr. | Teil-Nr. | Stück-<br>Zahl | Deutsch          | English          | Français          | Español            | Nummer/Bemerkung                                  | ETK |
|------------|----------|----------------|------------------|------------------|-------------------|--------------------|---|-----|
| 102        | 116 4003 | 1              | WELLENDICHRING   | SHAFT SEAL       | JOINT D'ARBRE     | ANILLO HERMET.EJE  | B 40X 58X10H 2938-NI                              | 01  |
| 103        | 233 3422 | 1              | LAGERDECKEL      | BEARING CAP      | CHAPEAU DE PALIER | TAPA SOPORTE       |   |     |
| 106        | 233 5951 | 16             | BOLZEN           | PIN/BOLT/STUD    | BOUTON/AXE        | BULON              |   | 01  |
| 107        | 233 5932 | 1              | NADELKAEFIG      | NEEDLE GAGE      | CAGE A AIGUILLES  | JAULA AGUJAS       |   | 01  |
| 111        | 116 8764 | 1              | NADELKAEFIG      | NEEDLE GAGE      | CAGE A AIGUILLES  | JAULA AGUJAS       | K 35 X 42X16 F H 4455<br>8003,AB FAHRGESTELL-NO.  | 01  |
| 112        | 116 8713 | 1              | NADELKAEFIG      | NEEDLE GAGE      | CAGE A AIGUILLES  | JAULA AGUJAS       | G 35 X 42X18 H 4455<br>8003,AB FAHRGESTELL-NO.    | 01  |
| 113        | 238 1081 | 52             | BEILAGE          | SHIM             | CALE              | SUPLEMENTO         | 8003,AB FAHRGESTELL-NO.<br>B285,SIEHE POS.973-980 |     |
| 114        | 233 6405 | 1              | ZYL.-ROLLENLAGER | PAR.ROLL.BEARING | ROULEM.ROUL.CYL.  | COJ.RODILL.CILINDR | 8003,AB FAHRGESTELL-NO.                           | 01  |
| 121        | 231 6795 | 1              | ZAHNRAD          | GEAR             | ROUE DENTEE       | RUEDA DENTADA      | B141,GANG 1 Z=53                                  |     |
| 124        | 238 1091 | 1              | ZAHNRAD          | GEAR             | ROUE DENTEE       | RUEDA DENTADA      | Z=16/31   |     |
| 126        | 230 1172 | 1              | ZAHNRAD          | GEAR             | ROUE DENTEE       | RUEDA DENTADA      | Z=28  |     |
| 127        | 233 4004 | 1              | ZAHNRAD          | GEAR             | ROUE DENTEE       | RUEDA DENTADA      | Z=43  |     |
| 132        | 233 3423 | 1              | ANTRIEBSWELLE    | DRIVE SHAFT      | ARBRE DE COMMANDE | EJE MOTRIZ         |   |     |
| 950        | 230 2056 | NB             | BEILAGE          | SHIM             | CALE              | SUPLEMENTO         | A=1,0 MM  |     |
| 951        | 230 2057 | NB             | BEILAGE          | SHIM             | CALE              | SUPLEMENTO         | A=1,1 MM  |     |
| 952        | 230 2056 | NB             | BEILAGE          | SHIM             | CALE              | SUPLEMENTO         | A=1,2 MM  |     |
| 953        | 230 2059 | NB             | BEILAGE          | SHIM             | CALE              | SUPLEMENTO         | A=1,3 MM  |     |
| 954        | 230 2060 | NB             | BEILAGE          | SHIM             | CALE              | SUPLEMENTO         | A=1,4 MM  |     |
| 955        | 230 2061 | NB             | BEILAGE          | SHIM             | CALE              | SUPLEMENTO         | A=1,5 MM  |     |
| 956        | 230 2062 | NB             | BEILAGE          | SHIM             | CALE              | SUPLEMENTO         | A=1,6 MM  |     |
| 957        | 230 2063 | NB             | BEILAGE          | SHIM             | CALE              | SUPLEMENTO         | A=1,7 MM  |     |
| 958        | 230 2046 | NB             | BEILAGE          | SHIM             | CALE              | SUPLEMENTO         | A=2,0 MM  |     |
| 959        | 230 2047 | NB             | BEILAGE          | SHIM             | CALE              | SUPLEMENTO         | A=2,25 MM   |     |
| 960        | 230 2048 | NB             | BEILAGE          | SHIM             | CALE              | SUPLEMENTO         | A=2,5 MM  |     |
| 961        | 230 2049 | NB             | BEILAGE          | SHIM             | CALE              | SUPLEMENTO         | A=2,75 MM   |     |
| 962        | 230 2050 | NB             | BEILAGE          | SHIM             | CALE              | SUPLEMENTO         | A=3,0 MM  |     |
| 963        | 230 2051 | NB             | BEILAGE          | SHIM             | CALE              | SUPLEMENTO         | A=3,25 MM   |     |
| 964        | 230 2052 | NB             | BEILAGE          | SHIM             | CALE              | SUPLEMENTO         | A=3,5 MM  |     |
| 965        | 230 2053 | NB             | BEILAGE          | SHIM             | CALE              | SUPLEMENTO         | A=3,75 MM   |     |
| 966        | 230 2054 | NB             | BEILAGE          | SHIM             | CALE              | SUPLEMENTO         | A=4,0 MM  |     |
| 967        | 230 9252 | NB             | BEILAGE          | SHIM             | CALE              | SUPLEMENTO         | A=1,75 MM   |     |
| 968        | 339 1875 | 1              | BEILAGE          | SHIM             | CALE              | SUPLEMENTO         | 1424-11-02.01<br>A=0,05 MM                        |     |
| 969        | 339 1876 | 1              | BEILAGE          | SHIM             | CALE              | SUPLEMENTO         | 1424-11-02.02<br>A=0,63 MM                        |     |
| 970        | 339 1877 | 1              | BEILAGE          | SHIM             | CALE              | SUPLEMENTO         | 1424-11-02.03<br>A=0,75 MM                        |     |
| 971        | 339 1878 | 1              | BEILAGE          | SHIM             | CALE              | SUPLEMENTO         | 1424-11-02.04<br>A=0,88 MM                        |     |
| 972        | 339 1879 | 1              | BEILAGE          | SHIM             | CALE              | SUPLEMENTO         | 1424-11-02.05<br>A=1,0 MM                         |     |

| Bild Nr. | Teile-Nr. | Stück-Zahl | Deutsch | English | Français | Español    | Nummer/Bemerkung | ETK |
|----------|-----------|------------|---------|---------|----------|------------|------------------|-----|
| 973      | 238 1082  | NB         | BEILAGE | SHIM    | CALE     | SUPLEMENTO | A=1,75 MM        |     |
| 974      | 238 1083  | NB         | BEILAGE | SHIM    | CALE     | SUPLEMENTO | A=2,0 MM         |     |
| 975      | 238 1084  | NB         | BEILAGE | SHIM    | CALE     | SUPLEMENTO | A=2,25 MM        |     |
| 976      | 238 1085  | NB         | BEILAGE | SHIM    | CALE     | SUPLEMENTO | A=2,5 MM         |     |
| 977      | 238 1086  | NB         | BEILAGE | SHIM    | CALE     | SUPLEMENTO | A=2,75 MM        |     |
| 978      | 238 1087  | NB         | BEILAGE | SHIM    | CALE     | SUPLEMENTO | A=3,0 MM         |     |
| 980      | 238 1088  | NB         | BEILAGE | SHIM    | CALE     | SUPLEMENTO | A=3,25 MM        |     |

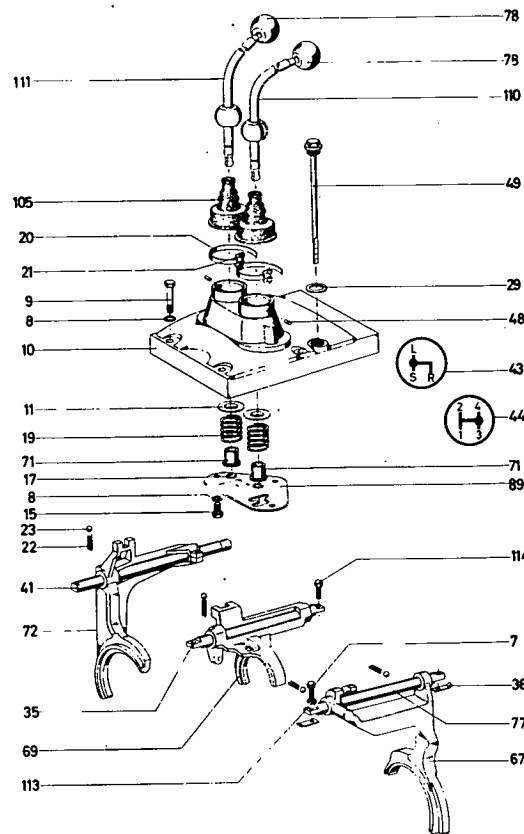

1446-12 501 5802

| Bld. Nr. | Teil-Nr. | Stück-Zahl | Deutsch           | English            | Français           | Español            | Nummer/Bemerkung                | ETK |
|----------|----------|------------|-------------------|--------------------|--------------------|--------------------|---------------------------------|-----|
| 7        | 111 2295 | 2          | SECHSKANTSCHRAUBE | HEX.BOLT           | VIS 6 PANS         | TORNILLO HEXAGONAL | M 6X 18 DIN 933- 8.8            |     |
| 8        | 110 2799 | 9          | FEDERRING         | SPRING LOCKWASHER  | RONDELLE GROWER    | ARANDELA ELASTICA  | A 8 DIN 128 A4C                 |     |
| 9        | 111 1145 | 6          | SECHSKANTSCHRAUBE | HEX.BOLT           | VIS 6 PANS         | TORNILLO HEXAGONAL | M 8X40 DIN 931-M8.8-A4C         |     |
| 10       | 230 1501 | 1          | SCHALTDECKEL      | COVER              | COUVERCLE COMMANDE | TAPA CAMBIO        |                                 |     |
| 11       | 339 1943 | 2          | SCHEIBE           | DISC/PANE/PLATE    | RONDELLE/DISQUE    | DISCO/CRISTAL/PLAT | 1424-12-05.12                   |     |
| 15       | 111 2305 | 3          | SECHSKANTSCHRAUBE | HEX.BOLT           | VIS 6 PANS         | TORNILLO HEXAGONAL | M8X15 DIN 933-M8.8-A4C          |     |
| 17       | 111 9824 | 2          | SPRENGRING        | SNAP RING          | AGRAFE CIRCULAIRE  | ANILLO RETENCION   | 14DIN 9045                      |     |
| 19       | 339 1944 | 2          | DRUCKFEDER        | COMPRESSION SPRING | RESSORT DE COMPR   | RESORTE PRESION    | 1424-12-05.33                   | 01  |
| 20       | 116 2511 | 2          | SCHLAUCHBAND      | HOSE STRAP         | RUBAN SERRAGE      | CINTA ATAMANGUERA  | D 5,5X385 H 735                 |     |
| 21       | 116 6346 | 2          | SCHLAUCHBINDER    | HOSE FASTENER      | ATTACHE RUBAN      | ATAMANGUERA        | C H 735                         |     |
| 22       | 338 6770 | 3          | DRUCKFEDER        | COMPRESSION SPRING | RESSORT DE COMPR   | RESORTE PRESION    | 1055-12-01.33                   | 01  |
| 23       | 111 6956 | 3          | KUGEL             | BALL               | BILLE/BOULE        | BOLA               | 8MM III DIN 5401                |     |
| 29       | 111 8737 | 1          | WASHER            | WASHER             | BAGUE D'ETANCHEITE | ANILLO DE JUNTA    | A 22X27 DIN 7603-CU             |     |
| 35       | 230 2272 | 1          | SCHALTSTANGE      | SHIFT ROD          | BARRE EMBRAYAGE    | BARRA CAMBIO       |                                 |     |
| 36       | 230 2213 | 2          | JUSTIERBLECH      | ADJUSTING PLATE    | TOLE DE REGLAGE    | CHAPA AJUSTE       |                                 |     |
| 41       | 230 3565 | 1          | SCHALTSTANGE      | SHIFT ROD          | BARRE EMBRAYAGE    | BARRA CAMBIO       |                                 |     |
| 43       | 230 3582 | 1          | SCHALTBILD        | SHIFTING GRAPHIC   | SCHEMA CONNEXIONS  | ESQUEMA CONEXIONES | B144,GRUPPE                     |     |
| 44       | 230 3581 | 1          | SCHALTBILD        | SHIFTING GRAPHIC   | SCHEMA CONNEXIONS  | ESQUEMA CONEXIONES | B141,GANG                       |     |
| 48       | 230 7600 | 2          | ZYLINDERSTIFT     | PARALLEL PIN       | GOUPILLE CYLINDR.  | PERNO CILINDRICO   |                                 |     |
| 49       | 231 1284 | 1          | MESSTAB           | GAUGE STICK        | JAUGE              | VARILLA MEDICION   |                                 |     |
| 67       | 231 3564 | 1          | SCHALTGABEL       | SHIFT FORK         | FOURCHETTE CDE     | HORQUILLA CAMBIO   | L-S                             |     |
| 69       | 231 3568 | 1          | SCHALTGABEL       | SHIFT FORK         | FOURCHETTE CDE     | HORQUILLA CAMBIO   | B141,GANG 3-4<br>B 297,SYNCHRON |     |
| 71       | 231 3631 | 2          | FEDERTELLER       | SPRING CAP         | CUVETTE DE RESSORT | PLATO RESORTE      | 1424-12-01.34                   |     |

| Bid Nr. | Teile-Nr. | Stück-Zahl | Deutsch           | English       | Français           | Español            | Nummer/Bemerkung            | ETK |
|---------|-----------|------------|-------------------|---------------|--------------------|--------------------|-----------------------------|-----|
| 72      | 231 6797  | 1          | SCHALTGABEL       | SHIFT FORK    | FOURCHETTE CDE     | HORQUILLA CAMBIO   | B141,GANG 1-2               |     |
| 77      | 231 6972  | 1          | SCHALTGABEL       | SHIFT FORK    | FOURCHETTE CDE     | HORQUILLA CAMBIO   | L-S-R                       |     |
| 78      | 116 3642  | 2          | KUGELKNOPF        | BALL KNOB     | BOUTON SPHERIQUE   | BOTON ESFERICO     | B40X14H 3517 PRESSTOFF MATT |     |
| 89      | 233 3416  | 1          | SCHALTKULISSE     | SHIFT GATE    | COULISSE           | PLACA GUIA CAMBIO  |                             |     |
| 105     | 339 1929  | 2          | FALTENBALG        | BELLOWS       | SOUFFLET           | FUELLE             | 1424-12-01.16               | 01  |
| 110     | 232 9589  | 1          | SCHALTKNUEPPEL    | SHIFT STICK   | LEVIER CDE VIT     | PALANCA DE CAMBIO  |                             |     |
| 113     | 110 7279  | 4          | FEDERSCHEIBE      | SPRING WASHER | KONDELLE ELASTIQUE | ARANDELA ELASTICA  | B 6 DIN 137-A4C             |     |
| 114     | 111 2264  | 2          | SECHSKANTSCHRAUBE | HEX.BOLT      | VIS 6 PANS         | TORNILLO HEXAGONAL | M 6X20 DIN 933-8.8-A4C      |     |

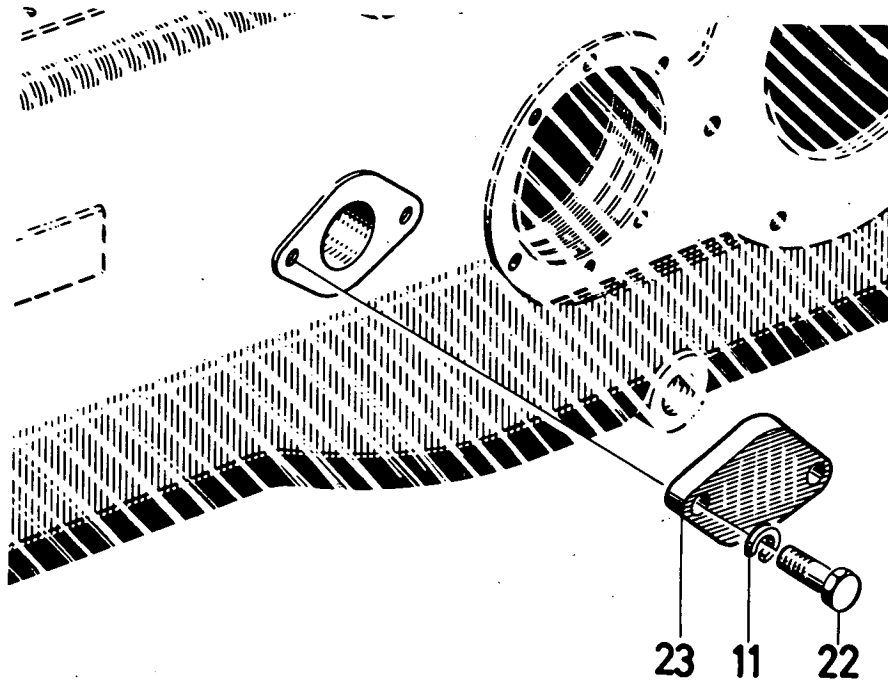

| 1446-14 500 5111 |           |            |                   |                   |                 |                    |                          |     |
|------------------|-----------|------------|-------------------|-------------------|-----------------|--------------------|--------------------------|-----|
| Bild Nr.         | Teile-Nr. | Stück-Zahl | Deutsch           | English           | Français        | Español            | Nummer/Bemerkung         | ETK |
| 11               | 110 2799  | 2          | FEDERRING         | SPRING LOCKWASHER | RONDELLE GROWER | ARANDELA ELASTICA  | A 8 DIN 128 A4C          |     |
| 22               | 111 2305  | 2          | SECHSKANTSCHRAUBE | HEX.BOLT          | VIS 6 PANS      | TORNILLO HEXAGONAL | M 8X 15 DIN.933- 8.8-A4C |     |
| 23               | 230 7702  | 1          | DECKEL            | COVER             | COUVERCLE       | TAPA               |                          |     |

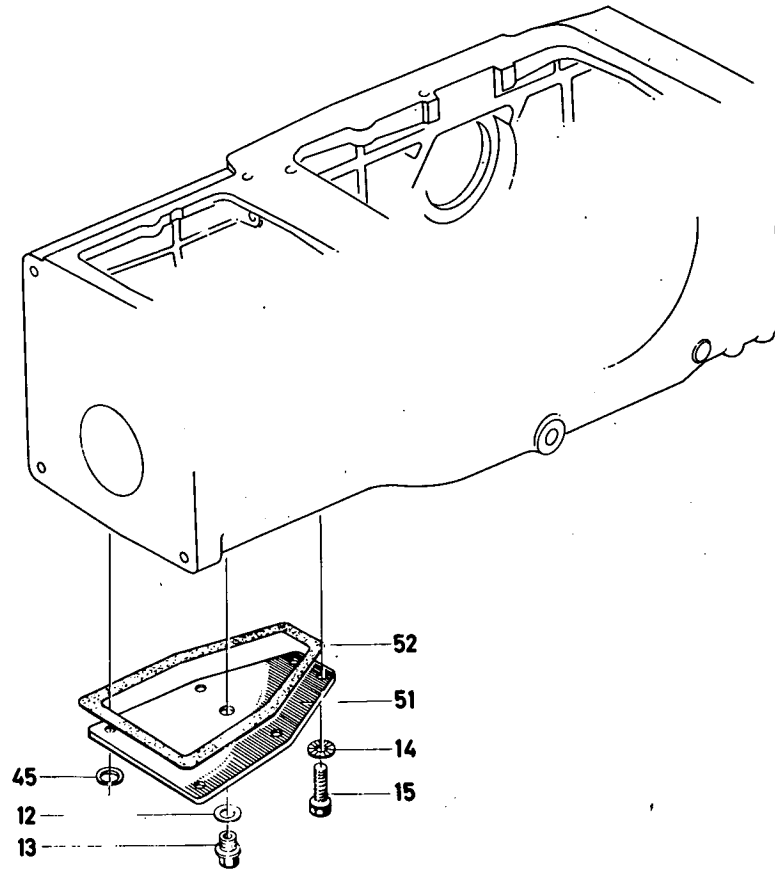

1424-17 500 5112

| Bild Nr. | Teile-Nr. | Stück-Zahl | Deutsch            | English        | Français           | Español            | Nummer/Bemerkung          | ETK |
|----------|-----------|------------|--------------------|----------------|--------------------|--------------------|---------------------------|-----|
| 12       | 111 8737  | 1          | DICHRING           | WASHER         | BAGUE D'ETANCHEITE | ANILLO DE JUNTA    | A 22 X 27 DIN 7603-CU     |     |
| 13       | 111 8979  | 1          | VERSCHLUSSSCHRAUBE | SCREW PLUG     | BOUCHON FILETE     | TAPON ROSCADO      | AM22X1,5 DIN 7604         |     |
| 14       | 116 9695  | 4          | SICHERUNGSSCHEIBE  | LOCKING WASHER | RONDELLE SECURITE  | ARANDELA SEGURIDAD | 12 H 2203                 |     |
| 15       | 111 2502  | 6          | SECHSKANTSCHRAUBE  | HEX. BOLT      | VIS 6 PANS         | TORNILLO HEXAGONAL | M12X 20 DIN 933-M 8.8-A4C |     |
| 45       | 111 8681  | 2          | DICHRING           | WASHER         | BAGUE D'ETANCHEITE | ANILLO DE JUNTA    | A 12 X 18 DIN 7603-CU     |     |
| 51       | 232 5797  | 1          | DECKEL             | COVER          | COUVERCLE          | TAPA               |                           |     |
| 52       | 232 5798  | 1          | DICHTUNG           | GASKET         | GARNITURE/JOINT    | JUNTA              |                           |     |



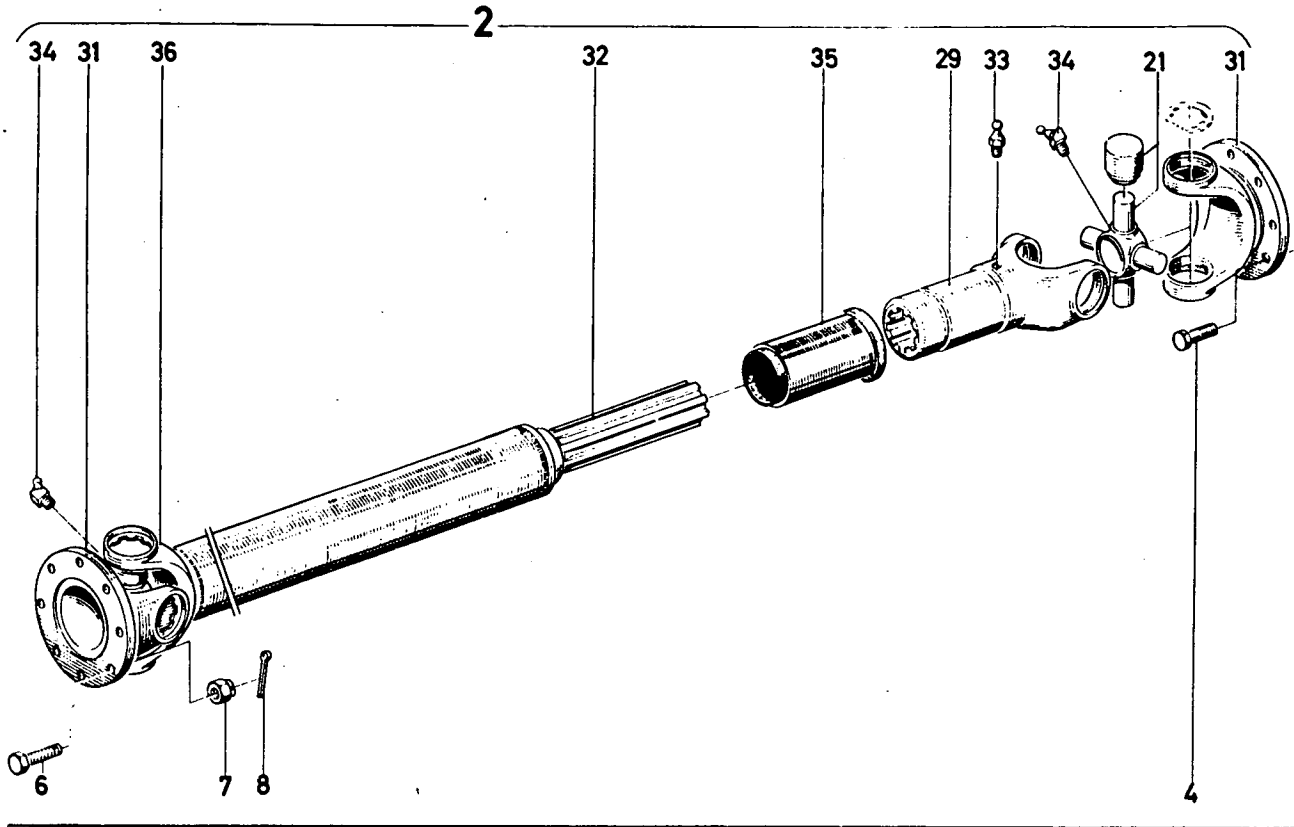

1005-21 500 4309

| Bild Nr. | Teile-Nr. | Stück-Zahl | Deutsch             | English         | Français           | Español            | Nummer / Bemerkung    | ETK |
|----------|-----------|------------|---------------------|-----------------|--------------------|--------------------|-----------------------|-----|
| 2        | 230 9759  | 1          | GELENKWELLE         | JOINT SHAFT     | ARBRE A CARDAN     | EJE ARTICULADO     |                       |     |
| 4        | 111 2314  | 6          | SECHSKANTSCHRAUBE   | HEX. BOLT       | VIS 6 PANS         | TORNILLO HEXAGONAL | M8X18 SK DIN 933-M8.8 |     |
| 6        | 230 6661  | 6          | SECHSKANTSCHRAUBE   | HEX. BOLT       | VIS 6 PANS         | TORNILLO HEXAGONAL |                       |     |
| 7        | 110 1514  | 6          | KRONENMUTTER        | CASTLE NUT      | ECROU CRENELE      | TUERCA CORDNA      | M8X1 DIN 935-10-A4C   |     |
| 8        | 110 6408  | 6          | SPLINT              | SPLIT PIN       | GOUPILLE FENDUE    | PASADOR ALETAS     | 2X18 DIN 94           |     |
| 21       | 238 6548  | 2          | GELENKREUZ          | UNIVERSAL JOINT | CROISILLON DE JT   | CRUCETA ARTICUL.   | B 337, VOLLSTAE NDIG  |     |
| 29       | 230 6850  | 1          | GELENK              | JOINT/HINGE     | JOINT/ARTICULATION | ARTICULAC.         |                       |     |
| 31       | 230 6852  | 2          | GELENKFLANSCH       | JOINT FLANGE    | FLASQUE D'ARTICUL  | BRIDA ARTICULAC.   |                       |     |
| 32       | 230 6853  | 1          | KEILNABENWELLE      | SPLINED SHAFT   | ARBRE MOYEU CANNEL | EJE CUBO CHAVETAD  |                       |     |
| 33       | 112 0694  | 1          | KEGEL SCHMIERNIPPEL | LUBE FITTING    | GRAISS EJR CONIQUE | ENGRASADOR CONICO  | AM10X1 DIN71412       |     |
| 34       | 112 0700  | 2          | KEGEL SCHMIERNIPPEL | LUBE FITTING    | GRAISS EJR CONIQUE | ENGRASADOR CONICO  | CM 8X1 DIN71412       |     |
| 35       | 230 6856  | 1          | PROFILSCHUTZ        | SECTION GUARD   | PATIN DE GARDE     | PROTECC PERFIL     |                       |     |
| 36       | 230 9766  | 1          | SCHN.ZAPFENGELENK   | PIVOT JOINT     | ARTICUL. ORIENT.   | MUNON SOLDAD. GIRO |                       |     |

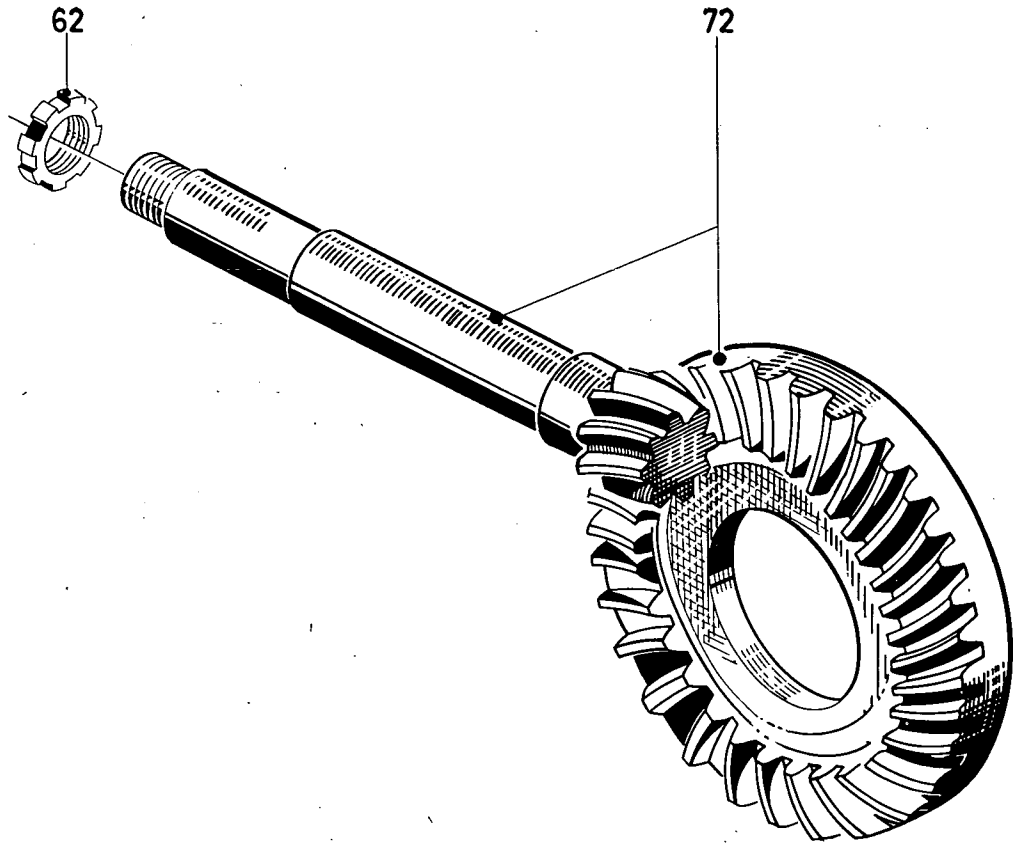

1446-23 500 5161

| Bild Nr. | Teile-Nr. | Stück-Zahl | Deutsch    | English     | Français       | Español         | Nummer / Bemerkung | ETK |
|----------|-----------|------------|------------|-------------|----------------|-----------------|--------------------|-----|
| 62       | 121 6035  | 1          | NUTHUTTER  | GROOVED NUT | ECROU RAINURE  | TUERCA RANURADA | 2 174 B 35         |     |
| 72       | 232 9624  | 1          | KEGELTRIEB | BEVEL DRIVE | COUPLE CONIQUE | GRUPO CONICO    |                    |     |

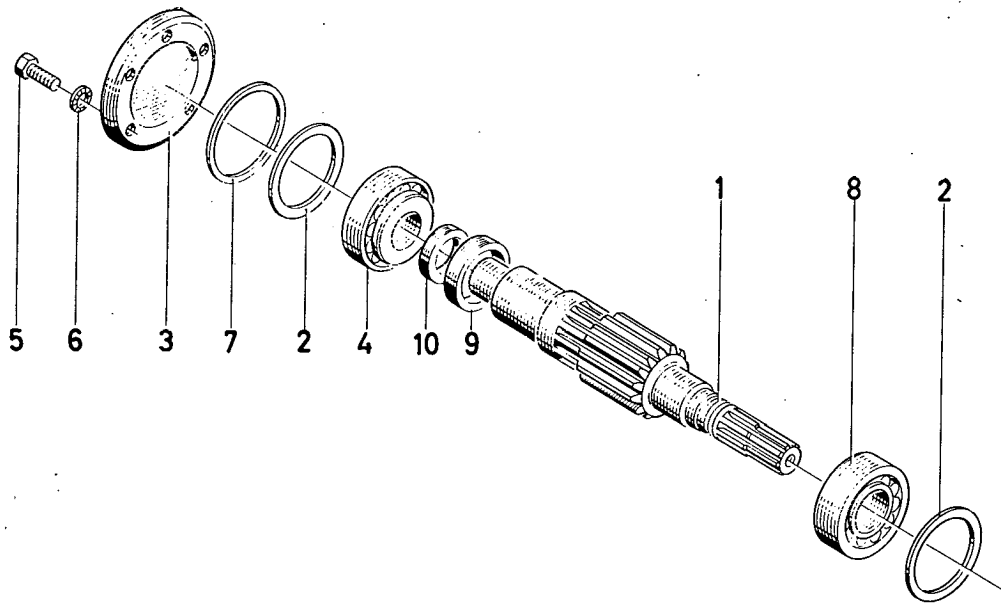

| Bild Nr. | Teile-Nr. | Stück-Zahl | Deutsch           | English             | Français          | Español             | 1446-23 500 5162<br>Nummer/Bemerkung      | ETK |
|----------|-----------|------------|-------------------|---------------------|-------------------|---------------------|---|-----|
| 1        | 232 5104  | 1          | ZWISCHENWELLE     | INTERMEDIATE SHAFT  | ARBRE INTERN.     | EJE INTERMEDIO      | Z=14                                      |     |
| 2        | 231 4341  | 1P         | BEILAGE           | SHIM                | CALE              | SUPLEMENTO          | 1445-23-21.10<br>B285, SIEHE POS. 950-956 |     |
| 3        | 231 6100  | 1          | DECKEL            | COVER               | COUVERCLE         | TAPA                |   |     |
| 4        | 339 3040  | 1          | KEGELPOLLENLAGER  | TAP. ROLLER BEARING | ROULEM A ROUL CON | COJ. RODIL. CONICOS | 1455-11-01.02                             | 01  |
| 5        | 111 2326  | 6          | SECHSKANTSCHRAUBE | HEX. BOLT           | VIS 6 PANS        | TORNILLO HEXAGONAL  | M 8X 22 DIN 933- 8.8-A4C                  |     |
| 6        | 116 9689  | 6          | SICHERUNGSSCHEIBE | LOCKING WASHER      | RONDELLE SECURITE | ARANDELA SEGURIDAD  | 8 H 2203                                  |     |
| 7        | 339 2522  | 1          | BEILAGE           | SHIM                | CALE              | SUPLEMENTO          | 1445-25-21.39                             |     |
| 8        | 110 1385  | 1          | KEGELROLLENLAGER  | TAP. ROLLER BEARING | ROULEM A ROUL CON | COJ. RODIL. CONICOS | 30310 A DIN 720                           | 01  |
| 9        | 231 3566  | 1          | ZWISCHENRING      | INTERMEDIATE RING   | BAGUE INTERMED.   | ANILLO INTERMEDIO   |   |     |
| 10       | 232 5105  | 1          | RING              | RING                | BAGUE/ANNEAU      | ANILLO              | 1445-23-21.34                             |     |
| 950      | 339 2503  | 1          | BEILAGE           | SHIM                | CALE              | SUPLEMENTO          | 1445-23-21.01<br>A=2,0 MM.                |     |
| 951      | 339 2504  | 1          | BEILAGE           | SHIM                | CALE              | SUPLEMENTO          | 1445-23-21.02<br>A=2,1 MM.                |     |
| 952      | 339 2505  | 1          | BEILAGE           | SHIM                | CALE              | SUPLEMENTO          | 1445-23-21.03<br>A=2,2 MM.                |     |
| 953      | 339 2508  | 1          | BEILAGE           | SHIM                | CALE              | SUPLEMENTO          | 1445-23-21.06<br>A=2,5 MM                 |     |
| 954      | 339 2511  | 1          | BEILAGE           | SHIM                | CALE              | SUPLEMENTO          | 1445-23-21.09<br>A=2,8                    |     |
| 955      | 339 2513  | 1          | BEILAGE           | SHIM                | CALE              | SUPLEMENTO          | 1445-23-21.12<br>A=3,0 MM                 |     |
| 956      | 339 2522  | 1          | BEILAGE           | SHIM                | CALE              | SUPLEMENTO          | 1445-23-21.39<br>A=5,5 MM.                |     |

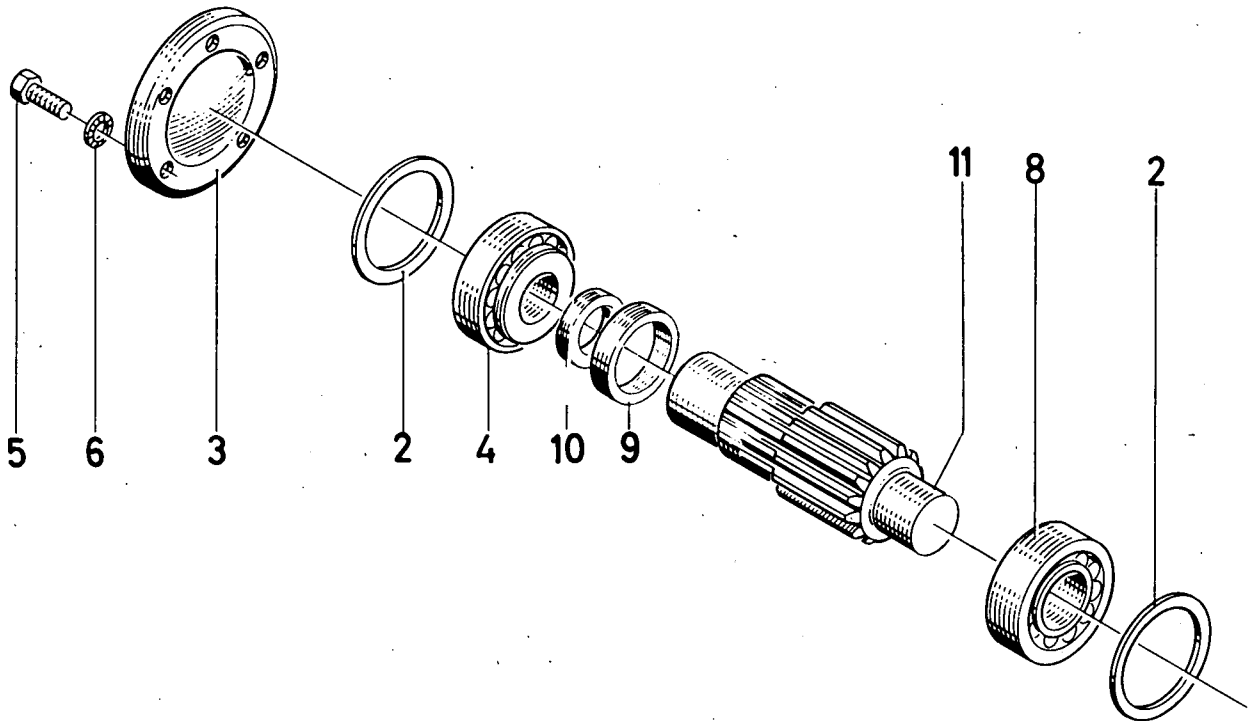

| Bild Nr. | Teile-Nr. | Stück-Zahl | Deutsch           | English             | Français          | Español             | 1446-23 501 5803<br>Nummer/Bemerkung      | ETK |
|----------|-----------|------------|-------------------|---------------------|-------------------|---------------------|---|-----|
| 2        | 231 4341  | 1P         | BEILAGE           | SHIM                | CALE              | SUPLEMENTO          | 1445-23-21.10<br>B285, SIEHE POS. 950-956 |     |
| 3        | 231 6100  | 2          | DECKEL            | COVER               | COUVERCLE         | TAPA                |   |     |
| 4        | 339 3040  | 1          | KEGELROLLENLAGER  | TAP. ROLLER BEARING | ROULEM A ROUL CON | COJ. RODIL. CONICOS | 1455-11-01.02                             | 01  |
| 5        | 111 2326  | 12         | SECHSKANTSCHRAUBE | HEX. BOLT           | VIS 6 PANS        | TORNILLO HEXAGONAL  | M8X22 DIN 933-8.8-A4C                     |     |
| 6        | 116 9689  | 12         | SICHERUNGSSCHEIBE | LOCKING WASHER      | RONDELLE SECURITE | ARANDELA SEGURIDAD  | 8H 2203                                   |     |
| 8        | 110 1386  | 1          | KEGELROLLENLAGER  | TAP. ROLLER BEARING | ROULEM A ROUL CON | COJ. RODIL. CONICOS | 30310A DIN 720                            | 01  |
| 9        | 231 3566  | 1          | ZWISCHENRING      | INTERMEDIATE RING   | BAGUE INTERMED.   | ANILLO INTERMEDIO   |   |     |
| 10       | 232 5105  | 1          | RING              | RING                | BAGUE/ANNEAU      | ANILLO              |   |     |
| 11       | 232 5136  | 1          | ZWISCHENWELLE     | INTERMEDIATE SHAFT  | ARBRE INTERM.     | EJE INTERMEDIO      |   |     |
| 950      | 339 2503  | 1          | BEILAGE           | SHIM                | CALE              | SUPLEMENTO          | 1445-23-21.01<br>A=2,0 MM                 |     |
| 951      | 339 2504  | 1          | BEILAGE           | SHIM                | CALE              | SUPLEMENTO          | 1445-23-21.02<br>A=2,1 MM                 |     |
| 952      | 339 2505  | 1          | BEILAGE           | SHIM                | CALE              | SUPLEMENTO          | 1445-23-21.03<br>A=2,2 MM                 |     |
| 953      | 339 2508  | 1          | BEILAGE           | SHIM                | CALE              | SUPLEMENTO          | 1445-23-21.06<br>A=2,5 MM                 |     |
| 954      | 339 2511  | 1          | BEILAGE           | SHIM                | CALE              | SUPLEMENTO          | 1445-23-21.09<br>A=2,8 MM                 |     |
| 955      | 339 2513  | 1          | BEILAGE           | SHIM                | CALE              | SUPLEMENTO          | 1445-23-21.12<br>A=3,0 MM                 |     |
| 956      | 339 2522  | 1          | BEILAGE           | SHIM                | CALE              | SUPLEMENTO          | 1445-23-21.39<br>A=5,5 MM                 |     |

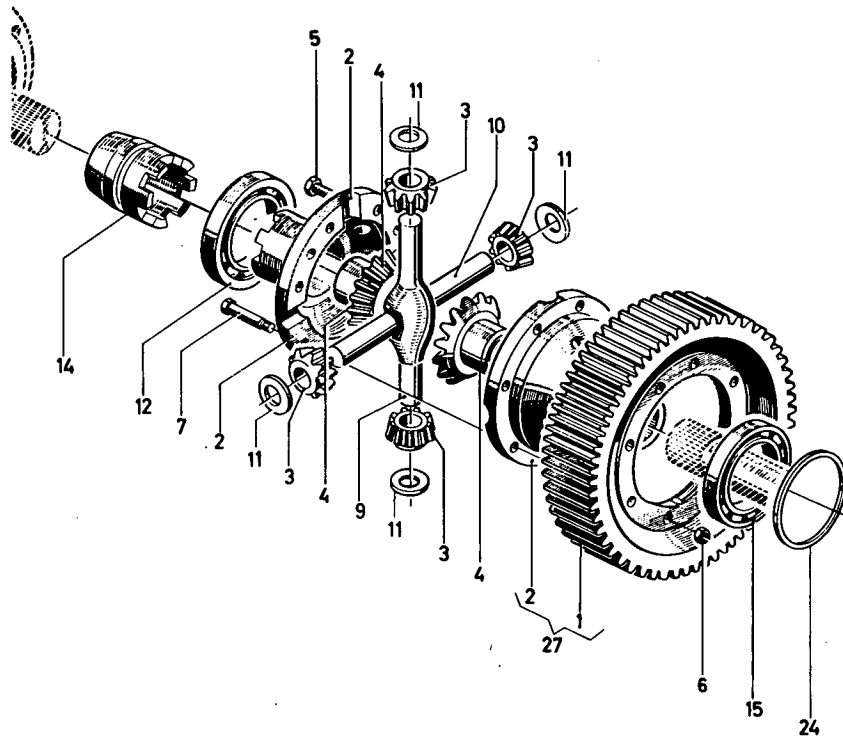

1446-24 501 5132

| Bad Nr. | Teile-Nr. | Stück-Zahl | Deutsch           | English            | Français          | Español            | Nummer/Bemerkung                    | ETK |
|---------|-----------|------------|-------------------|--------------------|-------------------|--------------------|-------------------------------------|-----|
| 1       | 237 0886  | 1          | ZAHNRAD           | GEAR               | ROJE DENTEE       | RUEDA DENTADA      | Z=67                                |     |
| 2       | 231 1802  | 1          | DIFFER.GEHAUSE    | DIFF.CASE          | CARTER DU DIFFER  | CAJA DIFERENCIAL   |                                     |     |
| 3       | 231 7066  | 4          | KEGELRAD          | BEVEL GEAR         | ENGREN CONIQUE    | RUEDA CONICA       | 1445-24-02.18                       |     |
| 4       | 230 0737  | 2          | KEGELRAD          | BEVEL GEAR         | ENGREN CONIQUE    | RUEDA CONICA       |                                     |     |
| 5       | 111 1499  | 4          | SECHSKANTSCHRAUBE | HEX.BOLT           | VIS 6 PANS        | TORNILLO HEXAGONAL | M 12X60 DIN 931-M10.9               |     |
| 6       | 111 2861  | 12         | SECHSKANTMUTTER   | HEX.NUT            | ECROU 6 PANS      | TUERCA HEXAGONAL   | M12 DIN 934-M10                     |     |
| 7       | 121 5909  | 8          | SKT.PASSSCHRAUBE  | FITTED BOLT        | VIS AJUST 6 PANS  | TORN.HEX.CALIBR.   | 2 010 A 7                           |     |
| 9       | 339 2531  | 1          | KREUZAPFEN        | SPIDER             | TENON EN CROIX    | MUNDON CRUCETA     | 1445-24-01.09                       |     |
| 10      | 339 2533  | 1          | KREUZAPFEN        | SPIDER             | TENON EN CROIX    | MUNDON CRUCETA     | 1445-24-01.11                       |     |
| 11      | 231 7068  | 4          | ANLAUFSCHIEBE     | STOP WASHER        | DISQUE BUTEE      | ARANDELA TOPE      | 1445-24-02.19                       |     |
| 12      | 110 2043  | 1          | KEGELROLLENLAGER  | TAP.ROLLER BEARING | ROULEM A ROUL CON | COJ.RODIL.CONICOS  | 32019X DIN 720                      | 01  |
| 14      | 231 1811  | 1          | KUPPLUNGSMUFFE    | CLUTCH SLEEVE      | MANCHON COUPLEUR  | MANGUITO ACOPLAM.  |                                     |     |
| 15      | 110 2042  | 1          | KEGELROLLENLAGER  | TAP.ROLLER BEARING | ROULEM A ROUL CON | COJ.RODIL.CONICOS  | 32015X DIN 720                      | 01  |
| 24      | 233 5935  | SZ         | BEILAGE           | SHIM               | CALE              | SUPLEMENTO         | B076,EINZELTEILE SIEHE POS. 950-966 |     |
| 27      | 237 3214  | IP         | DIFFER.GEHAUSE    | DIFF.CASE          | CARTER DU DIFFER  | CAJA DIFERENCIAL   |                                     |     |
| 950     | 233 5937  | 1          | BEILAGE           | SHIM               | CALE              | SUPLEMENTO         | A=1,4 MM                            |     |
| 951     | 233 5976  | 1          | BEILAGE           | SHIM               | CALE              | SUPLEMENTO         | A=1,5 MM                            |     |
| 952     | 233 5938  | 1          | BEILAGE           | SHIM               | CALE              | SUPLEMENTO         | A=1,6 MM                            |     |
| 953     | 233 5971  | 1          | BEILAGE           | SHIM               | CALE              | SUPLEMENTO         | A=1,7 MM                            |     |
| 954     | 233 5939  | 1          | BEILAGE           | SHIM               | CALE              | SUPLEMENTO         | A=1,8 MM                            |     |
| 955     | 233 5972  | 1          | BEILAGE           | SHIM               | CALE              | SUPLEMENTO         | A=1,9 MM                            |     |

| Bild<br>Nr. | Tele-Nr. | Stück-<br>Zahl | Deutsch | English | Français | Español    | Nummer/Bemerkung | ETK |
|-------------|----------|----------------|---------|---------|----------|------------|------------------|-----|
| 956         | 233 5940 | 1              | BEILAGE | SHIM    | CALE     | SUPLEMENTO | A=2,0 MM         |     |
| 957         | 233 5973 | 1              | BEILAGE | SHIM    | CALE     | SUPLEMENTO | A=2,1 MM         |     |
| 958         | 233 5941 | 1              | BEILAGE | SHIM    | CALE     | SUPLEMENTO | A=2,2 MM         |     |
| 959         | 233 5974 | 1              | BEILAGE | SHIM    | CALE     | SUPLEMENTO | A=2,3 MM         |     |
| 960         | 233 5942 | 1              | BEILAGE | SHIM    | CALE     | SUPLEMENTO | A=2,4 MM         |     |
| 961         | 233 5975 | 1              | BEILAGE | SHIM    | CALE     | SUPLEMENTO | A=2,5 MM         |     |
| 962         | 233 5943 | 1              | BEILAGE | SHIM    | CALE     | SUPLEMENTO | A=2,6 MM         |     |
| 963         | 233 5976 | 1              | BEILAGE | SHIM    | CALE     | SUPLEMENTO | A=2,7 MM         |     |
| 964         | 233 5944 | 1              | BEILAGE | SHIM    | CALE     | SUPLEMENTO | A=2,8 MM         |     |
| 965         | 233 5977 | 1              | BEILAGE | SHIM    | CALE     | SUPLEMENTO | A=2,9 MM         |     |
| 966         | 233 5946 | 1              | BEILAGE | SHIM    | CALE     | SUPLEMENTO | A=3,0 MM         |     |

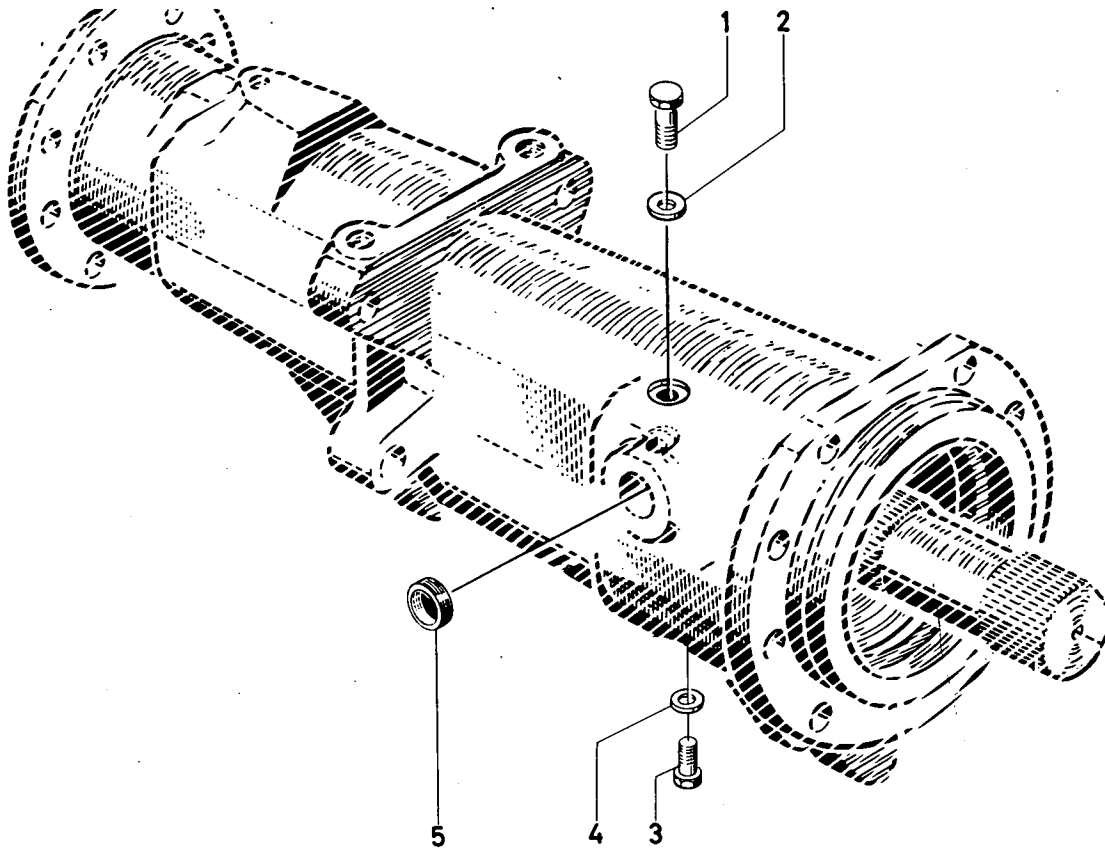

|          |           | 1446-25 500 5164 |                    |                |                    |                    |                           |     |
|----------|-----------|------------------|--------------------|----------------|--------------------|--------------------|---------------------------|-----|
| Bild Nr. | Teile-Nr. | Stück-Zahl       | Deutsch            | English        | Français           | Español            | Nummer/Bemerkung          | ETK |
| 1        | 111 2295  | 1                | SECHSKANTSCHRAUBE  | HEX. BOLT      | VIS 6 PANS         | TORNILLO HEXAGONAL | M 8 X 10 DIN 933- 8.8-A4C |     |
| 2        | 111 8654  | 1                | DICHTRING          | WASHER         | BAGUE D'ETANCHEITE | ANILLO DE JUNTA    | A 8 X 14 DIN 7603-CU      |     |
| 3        | 111 8979  | 1                | VERSCHLUSSSCHRAUBE | SCREW PLUG     | BOUCHON FILETE     | TAPON ROSCADO      | AM22X1,5 DIN 7604         |     |
| 4        | 111 8737  | 1                | DICHTRING          | WASHER         | BAGUE D'ETANCHEITE | ANILLO DE JUNTA    | A 22 X 27 DIN 7603-CU     |     |
| 5        | 116 5830  | 1                | KERNLOCHVERSCHLUSS | CORE HOLE PLUG | BOUCHON TROU DESS  | CIERRE MACHO       | 825 H 711                 |     |

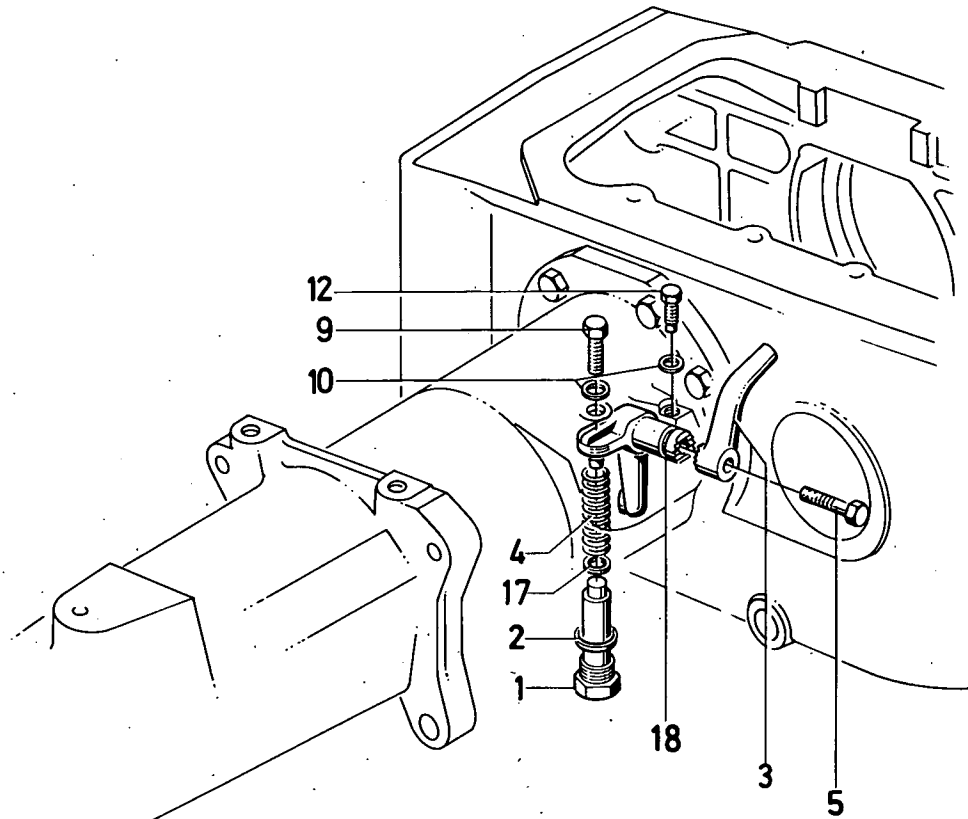

1425-25 500 5241

| Bild Nr. | Teile-Nr. | Stück-Zahl | Deutsch            | English         | Français           | Español            | Nummer/Bemerkung          | EIK |
|----------|-----------|------------|--------------------|-----------------|--------------------|--------------------|---------------------------|-----|
| 1        | 339 2540  | 1          | SECHS-KANTSCHRAUBE | HEX. BOLT       | VIS 6 PANS         | TORNILLO HEXAGONAL | 1445-25-01.02             |     |
| 2        | 111 8737  | 1          | DICHTRING          | WASHER          | BAGUE D'ÉTANCHEITE | ANILLO DE JUNTA    | A 22 X 27 DIN 7603-CU     |     |
| 3        | 347 1122  | 1          | UMLFNHEBEL         | REVERSING LEVER | LEVIER DE RENVOI   | PALANCA INVERSION  | 1445-25-02.03             |     |
| 4        | 339 7604  | 1          | SCHRAUBENFEDER     | HELICAL SPRING  | RESSORT A BOUDIN   | RESORTE HELICOIDAL | 1124-25-01.05             | 01  |
| 5        | 111 2429  | 1          | SECHS-KANTSCHRAUBE | HEX. BOLT       | VIS 6 PANS         | TORNILLO HEXAGONAL | M10X 30 DIN 933- 8.8-A4C  |     |
| 9        | 111 2322  | 1          | SECHS-KANTSCHRAUBE | HEX. BOLT       | VIS 6 PANS         | TORNILLO HEXAGONAL | M 8 X 20 DIN 933- 8.8-A4C |     |
| 10       | 111 8654  | 2          | DICHTRING          | WASHER          | BAGUE D'ÉTANCHEITE | ANILLO DE JUNTA    | A 8 X 14 DIN 7603-CU      |     |
| 12       | 110 8139  | 1          | SECHS-KANTSCHRAUBE | HEX. BOLT       | VIS 6 PANS         | TORNILLO HEXAGONAL | M 8 X 20 DIN 561- 8.8 A4C |     |
| 17       | 110 7547  | 1          | SCHEIBE            | DISC/PANE/PLATE | RONDELLE/DISQUE    | DISCO/CRISTAL/PLAT | 10,5DIN 433-ST            |     |
| 18       | 232 5021  | 1          | HEBEL              | LEVER/ARM       | LEVIER             | PALANCA            |                           |     |



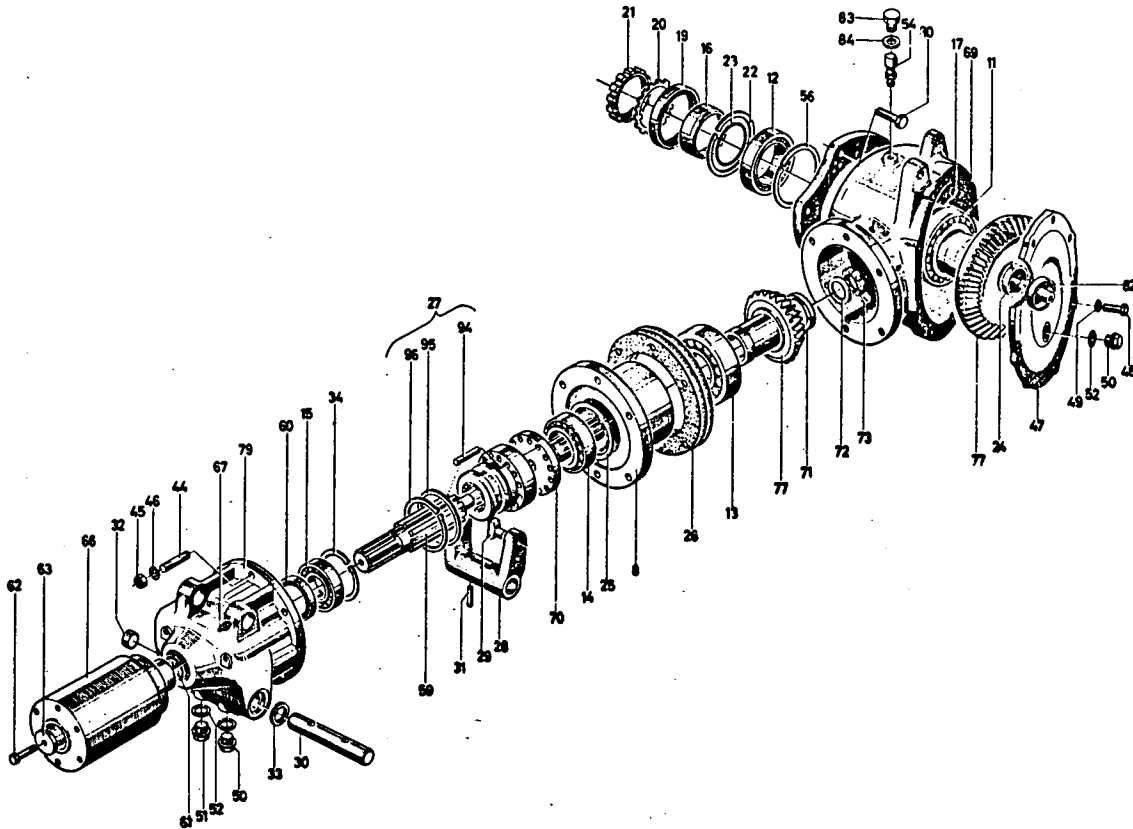

| Bkl<br>Nr | Teile-Nr. | Stück-<br>Zahl | Deutsch            | English            | Français           | Español             | Nummer/Bemerkung                        | ETK |
|-----------|-----------|----------------|--------------------|--------------------|--------------------|---------------------|---|-----|
| 8         | 230 6229  | 1              | FLANSCHBUCHSE      | FLANGED BUSH       | DOUILLE A BRIDE    | CASQUILLO BRIDA     |   |     |
| 11        | 110 9965  | 1              | KEGELROLLENLAGER   | TAP.ROLLER BEARING | ROULEM A ROUL CON  | COJ.FODIL.CONICOS   | 30214J2DIN 720                          | 01  |
| 12        | 110 1596  | 1              | KEGELROLLENLAGER   | TAP.ROLLER BEARING | ROULEM A ROUL CON  | COJ.FODIL.CONICOS   | 32013X DIN 720                          | 01  |
| 13        | 112 5780  | 1              | KEGELROLLENLAGER   | TAP.ROLLER BEARING | ROULEM A ROUL CON  | COJ.FODIL.CONICOS   | 30311J2DIN 720                          | 01  |
| 14        | 110 1597  | 1              | KEGELROLLENLAGER   | TAP.ROLLER BEARING | ROULEM A ROUL CON  | COJ.FODIL.CONICOS   | 32011X DIN 720                          | 01  |
| 15        | 110 9062  | 1              | RILLENKUGELLAGER   | BALL BEARING       | ROUL RAINURE BILLE | COJ.BOLAS FIJO      | 6208 DIN 625                            | 01  |
| 16        | 230 6297  | 1              | ABSTANDRING        | SPACER RING        | BAGUE ECARTEMENT   | ARO DISTANCIARIO    |   |     |
| 17        | 230 6739  | 1              | AUSGLEICHKOEPPER   | COMPENSATING BODY  | CORPS DE COMPENS   | CUERPO COMPENSAC.   | A=3,0 MM.<br>B355,WAHLWEISE POS.950-966 |     |
| 19        | 116 0701  | 1              | WELLENDICHTRING    | SHAFT SEAL         | JOINT D'ARBRE      | ANILLO HERMET.EJE   | A 80X100 X10 H 2940-NI                  | 01  |
| 20        | 230 6235  | 1              | SICHERUNGSBLECH    | LOCKING PLATE      | TOLE DE SECURITE   | CHAPA SEGURIDAD     |   | 01  |
| 21        | 112 0618  | 1              | NUTMUTTER          | GROOVED NUT        | ECROU RAINURE      | TUERCA RANURADA     | M 65X1,5 DIN70852                       |     |
| 22        | 110 7862  | 1              | SICHERUNGSRING     | CIRCLIP            | CIRCLIP            | CIRCLIP             | 100X3 DIN 472                           |     |
| 23        | 116 9589  | 1              | RUNDGUMMRING       | O-RING             | ANNEAU TORIQUE     | ANILLO GOMA REDONDO | 65 X 2 H 721                            | 01  |
| 24        | 116 5839  | 1              | KERNLOCHVERSCHLUSS | CORE HOLE PLUG     | BOUCHON TROU DESS  | CIERRE MACHO        | 850 H 711<br>B003,BIS FAHRGESTELL-NO    |     |
| 25        | 110 7859  | 1              | SICHERUNGSRING     | CIRCLIP            | CIRCLIP            | CIRCLIP             | 90X4 DIN 472                            |     |
| 26        | 230 6730  | NB             | BEILAGE            | SHIM               | CALE               | SUPLEMENTO          | A=0,5 MM.<br>B355,WAHLWEISE POS.967-971 |     |
| 27        | 230 6239  | 1              | TRAEGER            | SUPPORT/CARRIER    | SUPPORT/POUTRE     | VIGA/SOPORTE        |   |     |
| 28        | 230 6227  | 1              | SCHALTGABEL        | SHIFT FORK         | FOURCHETTE CDE     | HORQUILLA CAMBIO    |   |     |
| 29        | 230 6242  | 2              | SCHALTGABEL        | SHIFT FORK         | FOURCHETTE CDE     | HORQUILLA CAMBIO    |   |     |
| 30        | 230 6244  | 1              | SCHALTWELLE        | SHIFTING SHAFT     | ARBRE COMMANDE     | EJE MANDO/CAMBIO    |   |     |
| 31        | 111 5459  | 2              | SPANNHUELSE        | DOWEL SLEEVE       | DOUILLE SERRAGE    | CASQUILLO FIADOR    | 6 X 40DIN 1481                          |     |
| 32        | 116 5830  | 1              | KERNLOCHVERSCHLUSS | CORE HOLE PLUG     | BOUCHON TROU DESS  | CIERRE MACHO        | 825 H 711                               |     |
| 33        | 116 0738  | 1              | WELLENDICHTRING    | SHAFT SEAL         | JOINT D'ARBRE      | ANILLO HERMET.EJE   | A 25X 35 X 7 H 2940-NI                  | 01  |

| Bid Nr. | Teile-Nr. | Stück-Zahl | Deutsch            | English           | Français              | Español            | Nummer/Bemerkung                                 | ETK |
|---------|-----------|------------|--------------------|-------------------|-----------------------|--------------------|--|-----|
| 34      | 110 7955  | 1          | SICHERUNGSRING     | CIRCLIP           | CIRCLIP               | CIRCLIP            | 80X2,5 DIN 472                                   |     |
| 44      | 111 3499  | 6          | STIFTSCHRAUBE      | STUD              | GOUJON                | ESPARRAGO          | M10 X 40 DIN 939- 8.8-A4C                        |     |
| 45      | 110 2659  | 6          | SECHSKANTMUTTER    | HEX.NUT           | ECROU 6 PANS          | TUEPCA HEXAGONAL   | M10 DIN 934-M 8 A4C                              |     |
| 46      | 110 2900  | 6          | FEDERING           | SPRING LOCKWASHER | RONDELLE GROWER       | ARANDELA ELASTICA  | A 10 DIN 128 A4C                                 |     |
| 47      | 230 6233  | 1          | DECKEL             | COVER             | COUVERCLE             | TAPA               |  |     |
| 48      | 111 2322  | 9          | SECHSKANTSCHRAUBE  | HEX.BOLT          | VIS 6 PANS            | TORNILLO HEXAGONAL | M 8 X 20 DIN 933- 8.8-A4C                        |     |
| 49      | 110 2799  | 8          | FEDERING           | SPRING LOCKWASHER | RONDELLE GROWER       | ARANDELA ELASTICA  | A 8 DIN 128 A4C                                  |     |
| 50      | 111 8980  | 2          | VERSCHLUSSSCHRAUBE | SCREW PLUG        | BOUCHON FILETE        | TAPON ROSCADO      | M22X1,5 DIN 7604 VZKC                            |     |
| 51      | 121 8437  | 1          | VERSCHLUSSSCHRAUBE | SCREW PLUG        | BOUCHON FILETE        | TAPON ROSCADO      | 2 814 M 2  | 01  |
| 52      | 111 8737  | 3          | DICHTRING          | WASHER            | BAGUE D'ETANCHEITE    | ANILLO DE JUNTA    | A 22 X 27 DIN 7603-CU                            |     |
| 54      | 230 3512  | 1          | ENTLUEFTUNGSVENTIL | BREATHER VALVE    | SOUP DEGAGEMENT D'AIR | VALV.PRG.AIRE      | 8003,BIS FAHRGESTELL-NO                          |     |
| 56      | 110 1512  | 1          | SICHERUNGSRING     | CIRCLIP           | CIRCLIP               | CIRCLIP            | 100X4 DIN 472                                    |     |
| 59      | 230 7445  | 1          | ANTRIEBSWELLE      | DRIVE SHAFT       | ARBRE DE COMMANDE     | EJE MOTRIZ         |  |     |
| 60      | 110 1562  | 1          | WELLENDICHTRING    | SHAFT SEAL        | JOINT D'ARBRE         | ANILLO HERMET.EJE  | B 50X 70 X10 H 2940-NI                           | 01  |
| 61      | 110 1561  | 1          | O-RING             | O-SEAL            | BAGUE TORIQUE         | ANILLO O           | 38 X 2 H 2927                                    | 01  |
| 62      | 110 6335  | 1          | SKT.DEHNSCHRAUBE   | WASTED BOLT       | VIS EXTENS 6 PANS     | TORN.HEX.EXPANSION | M10X1 X 40 H 803-10.9                            | 01  |
| 63      | 231 0951  | 1          | SCHEIBF            | DISC/PANE/PLATE   | RONDELLE/DISQUE       | DISCO/CRISTAL/PLAT |  |     |
| 66      | 231 5407  | 1          | ANLAUFKUPPLUNG     | OVERLOAD CLUTCH   | LIMITEUR COUPLE       | ACOPLAM.ARRANQUE   |  |     |
| 67      | 110 8225  | 2          | KEGELSCHMIERNIPPEL | LUBE FITTING      | GRATISSEUR CONIQUE    | ENGRASADOR CONICO  | SA 8H 3360                                       | 01  |
| 69      | 231 6231  | 1          | GEHAEUSE           | HOUSING/CASE      | CARTER/BOITIER        | CAJA/BLOQUE/CUERPO |  |     |
| 70      | 231 5780  | 1          | FLANSCHWELLE       | FLANGED SHAFT     | ARBRE A BRIDE         | EJE BRIDA          |  |     |
| 71      | 231 5981  | 1          | INSENSCHEIBE       | TAB WASHER        | RONDELLE A TALON      | ARANDELA RESALTO   |  |     |
| 72      | 121 1699  | 1          | SICHERUNGSBLECH    | LOCKING PLATE     | TOLE DE SECURITE      | CHAPA SEGURIDAD    | 2 250 A 9  |     |
| 73      | 121 1693  | 1          | NUTMUTTER          | GROOVED NUT       | ECROU RAINURE         | TUERCA RANURADA    | 2 174 B 30                                       |     |
| 77      | 231 9524  | 1          | KEGELTRIEB         | BEVEL DRIVE       | COUPLE CONIQUE        | GRUPO CONICO       | 2-18/29  |     |
| 79      | 231 5661  | 1          | SCHALTGEHAEUSE     | HOUSING           | CARTER COMMANDE       | CAJA CAMBIO/MANDO  |  |     |
| 80      | 110 3005  | 9          | SECHSKANTSCHRAUBE  | HEX.BOLT          | VIS 6 PANS            | TORNILLO HEXAGONAL | M12 X 45 DIN 609-M 8.8 VZKC                      |     |
| 82      | 238 4219  | 1          | ENTLUEFTUNGSRÖHR   | BREATHER PIPE     | TUBE DE DESAERAGE     | TUBO PRG.AIRE      | 8027,AB FAHRGESTELL-NO                           |     |
| 83      | 111 8993  | 1          | VERSCHLUSSSCHRAUBE | SCREW PLUG        | BOUCHON FILETE        | TAPON ROSCADO      | M10X1 DIN 7604 VZKC<br>8027,AB FAHRGESTELL-NO    |     |
| 84      | 111 8659  | 1          | DICHTRING          | WASHER            | BAGUE D'ETANCHEITE    | ANILLO DE JUNTA    | A 10 X 13,5DIN 7603-CU<br>8027,AB FAHRGESTELL-NO |     |
| 94      | 230 6247  | 16         | BOLZEN             | PIN/BOLT/STUD     | BOULON/AXE            | BULON              |  | 01  |
| 95      | 230 6241  | 1          | RING               | RING              | BAGUE/ANNEAU          | ANILLO             |  |     |
| 96      | 110 7780  | 1          | SICHERUNGSRING     | CIRCLIP           | CIRCLIP               | CIRCLIP            | 75X2,5 DIN 471                                   | 01  |
| 950     | 230 6740  | NB         | BEILAGE            | SHIM              | CALE                  | SUPLEMENTO         | A=3,1  |     |
| 951     | 230 6741  | NB         | BEILAGE            | SHIM              | CALE                  | SUPLEMENTO         | A=3,2  |     |
| 952     | 230 6742  | NB         | BEILAGE            | SHIM              | CALE                  | SUPLEMENTO         | A=3,3  |     |
| 953     | 230 6743  | NB         | BEILAGE            | SHIM              | CALE                  | SUPLEMENTO         | A=3,4  |     |
| 954     | 230 6744  | NB         | BEILAGE            | SHIM              | CALE                  | SUPLEMENTO         | A=3,5  |     |
| 955     | 230 6745  | NB         | BEILAGE            | SHIM              | CALE                  | SUPLEMENTO         | A=3,6  |     |
| 956     | 230 6746  | NB         | BEILAGE            | SHIM              | CALE                  | SUPLEMENTO         | A=3,7  |     |
| 957     | 230 6745  | NB         | BEILAGE            | SHIM              | CALE                  | SUPLEMENTO         | A=3,8  |     |
| 958     | 230 6747  | NB         | BEILAGE            | SHIM              | CALE                  | SUPLEMENTO         | A=3,9  |     |
| 959     | 230 6747  | NB         | BEILAGE            | SHIM              | CALE                  | SUPLEMENTO         | A=4,0  |     |
| 960     | 230 6750  | NB         | BEILAGE            | SHIM              | CALE                  | SUPLEMENTO         | A=4,1  |     |

| Bild<br>Nr. | Teil-Nr. | Stück-<br>Zahl | Deutsch | English | Français | Español    | Nummer/Bemerkung | ETK |
|-------------|----------|----------------|---------|---------|----------|------------|------------------|-----|
| 961         | 230 6751 | NB             | BEILAGE | SHIM    | CALE     | SUPLEMENTO | A=4,2            |     |
| 962         | 230 6752 | NB             | BEILAGE | SHIM    | CALE     | SUPLEMENTO | A=4,3            |     |
| 963         | 230 6753 | NB             | BEILAGE | SHIM    | CALE     | SUPLEMENTO | A=4,4            |     |
| 964         | 230 6754 | NB             | BEILAGE | SHIM    | CALE     | SUPLEMENTO | A=4,5            |     |
| 965         | 230 6755 | NB             | BEILAGE | SHIM    | CALE     | SUPLEMENTO | A=4,6            |     |
| 966         | 230 6756 | NB             | BEILAGE | SHIM    | CALE     | SUPLEMENTO | A=4,7            |     |
| 967         | 230 6731 | NB             | BEILAGE | SHIM    | CALE     | SUPLEMENTO | A=0,6            |     |
| 968         | 230 6732 | NB             | BEILAGE | SHIM    | CALE     | SUPLEMENTO | A=0,7            |     |
| 969         | 230 6733 | NB             | BEILAGE | SHIM    | CALE     | SUPLEMENTO | A=0,8            |     |
| 970         | 230 6734 | NB             | BEILAGE | SHIM    | CALE     | SUPLEMENTO | A=0,9            |     |
| 971         | 230 6735 | NB             | BEILAGE | SHIM    | CALE     | SUPLEMENTO | A=1,0            |     |

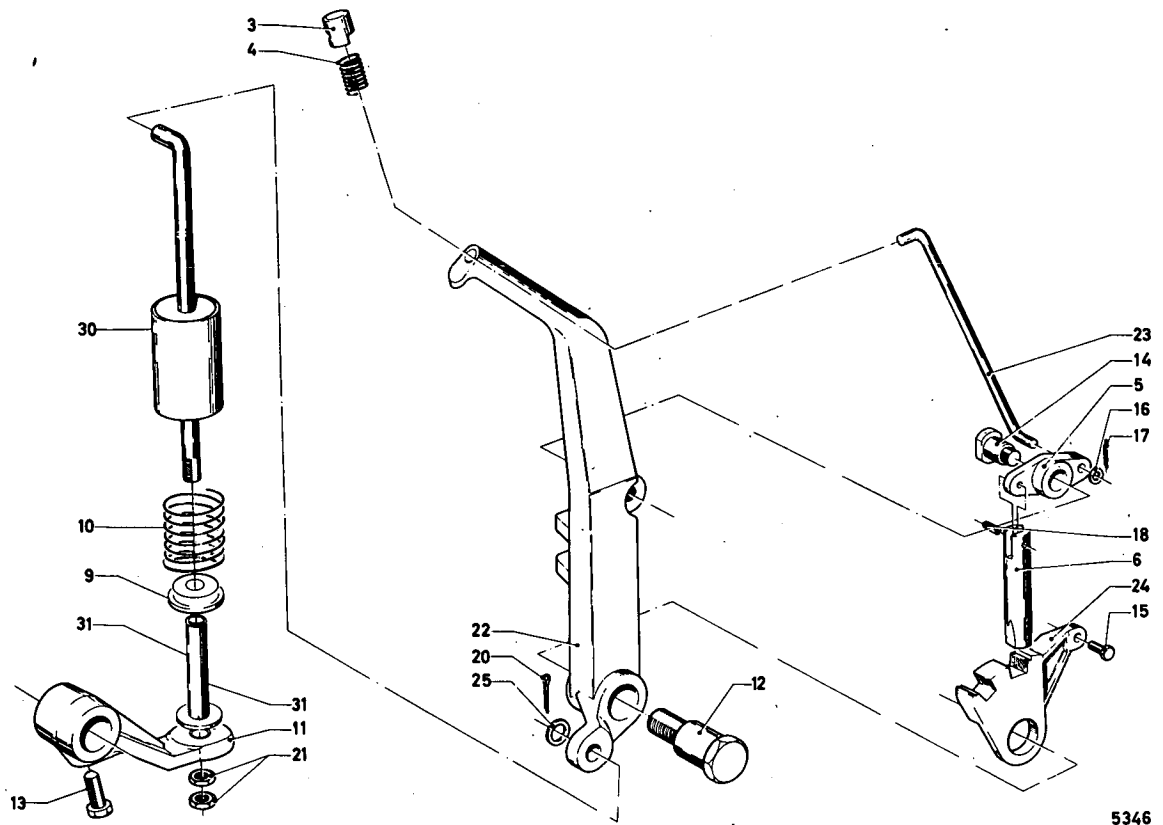

1446-26 500 5346

| Bld Nr. | Teile-Nr. | Stück-Zahl | Deutsch           | English            | Français           | Español            | Nummer/Bemerkung         | ETK |
|---------|-----------|------------|-------------------|--------------------|--------------------|--------------------|--------------------------|-----|
| 3       | 338 8929  | 1          | DRUCKKNOPF        | PUSHBUTTON         | BOUTON-POUSSOIR    | PULSADOR           | 1136-29-03.07            |     |
| 4       | 338 8928  | 1          | SCHRAUBENFEDER    | HELICAL SPRING     | RESSORT A BOUDIN   | RESORTE HELICOIDAL | 1136-29-03.06            | 01  |
| 5       | 230 6258  | 1          | UMLENKHEBEL       | REVERSING LEVER    | LEVIER DE RENVOI   | PALANCA INVERSION  |                          |     |
| 6       | 230 6257  | 1          | STIFT             | PIN                | CHEVILLE/GOUPILLE  | PERNO/PASADOR      |                          |     |
| 9       | 230 6246  | 1          | FEDERTELLER       | SPRING CAP         | CUVETTE DE RESSORT | PLATO RESORTE      |                          |     |
| 10      | 230 6247  | 1          | DRUCKFEDER        | COMPRESSION SPRING | RESSORT DE COMPR   | RESORTE PRESION    |                          |     |
| 11      | 230 6245  | 1          | SCHALTHEBEL       | SHIFT LEVER        | LEVIER COMMANDE    | PALANCA CAMBIO     |                          |     |
| 12      | 230 6256  | 1          | BOLZEN            | PIN/BOLT/STUD      | BOULON/AXE         | BULON              |                          |     |
| 13      | 230 1561  | 1          | STELLSCHRAUBE     | SET SCREW          | VIS DE REGLAGE     | TORNILLO GRADUAC.  |                          |     |
| 14      | 111 5001  | 1          | BOLZEN            | PIN/BOLT/STUD      | BOULON/AXE         | BULON              | 12H11M10X 13 X 28DIN     |     |
| 15      | 111 2418  | 1          | SECHSKANTSCHRAUBE | HEX.BOLT           | VIS 6 PANS         | TORNILLO HEXAGONAL | M10X 25 DIN 933- 8.8-A4C |     |
| 16      | 110 7095  | 1          | SCHEIBE           | DISC/PANE/PLATE    | RONDELLE/DISQUE    | DISCO/CRISTAL/PLAT | A 6,40DIN 125-ST-A4C     |     |
| 17      | 110 6404  | 1          | SPLINT            | SPLIT PIN          | GOUPILLE FENDUE    | PASADOR ALETAS     | 2 X 12DIN 94-A4C         |     |
| 18      | 111 5407  | 1          | SPANNHUELSE       | DOWEL SLEEVE       | DOUVILLE SERRAGE   | CASQUILLO FIADOR   | 3 X 16DIN 1481           |     |
| 20      | 110 6447  | 1          | SPLINT            | SPLIT PIN          | GOUPILLE FENDUE    | PASADOR ALETAS     | 4 X 20DIN 94-A4C         |     |
| 21      | 111 3152  | 2          | SECHSKANTMUTTER   | HEX.NUT            | ECROU 6 PANS       | TUERCA HEXAGONAL   | M12 DIN 936-M55 VZKC     |     |
| 22      | 231 5423  | 1          | HANDHEBEL         | HAND LEVER         | LEVIER A MAIN      | PALANCA MANUAL     |                          |     |
| 23      | 231 5424  | 1          | DRUCKSTANGE       | THRUST ROD         | BRAS DE LEVIER     | VARILLA PRESION    |                          |     |
| 24      | 231 5425  | 1          | SEGMENT           | QUADRANT/SEGMENT   | SEGMENT/SECTEUR    | SEGMENTO           |                          |     |
| 25      | 110 7554  | 1          | SCHEIBE           | DISC/PANE/PLATE    | RONDELLE/DISQUE    | DISCO/CRISTAL/PLAT | 13,50DIN 433-ST-A4C      |     |
| 30      | 237 1399  | 1          | SCHALTSTANGE      | SHIFT ROD          | BARRE EMBRAYAGE    | BARRA CAMBIO       |                          |     |
| 31      | 237 1395  | 1          | ABSTANDROHR       | SPACER TUBE        | TUBE ECARTEMENT    | TUBO DISTANCIARIO  |                          |     |

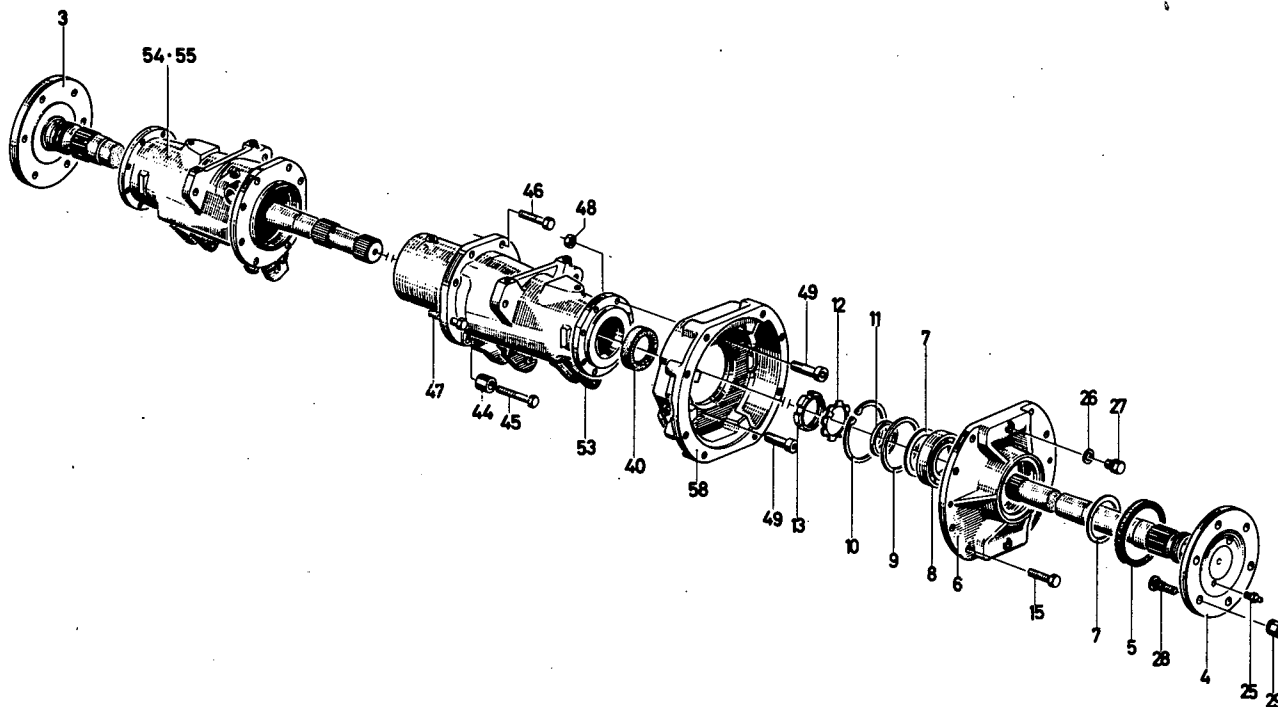

| Bild Nr. | Teile-Nr. | Stück-Zahl | Deutsch            | English           | Français            | Español             | 1446-27 501 5804<br>Nummer/Bemerkung | ETK |
|----------|-----------|------------|--------------------|-------------------|---------------------|---------------------|--------------------------------------|-----|
| 3        | 231 5917  | 1          | STECKWELLE         | PLUG-IN SHAFT     | DEMI-ARBRE FLOTT    | EJE ENCHUFE         | B257, RECHTS                         |     |
| 4        | 231 5915  | 1          | STECKWELLE         | PLUG-IN SHAFT     | DEMI-ARBRE FLOTT    | EJE ENCHUFE         | B195, LINKS                          |     |
| 5        | 231 5962  | 2          | RING               | RING              | BAGUE/ANNEAU        | ANILLO              |                                      | 01  |
| 6        | 232 6077  | 2          | DECKEL             | COVER             | COUVERCLE           | TAPA                |                                      |     |
| 7        | 116 0133  | 4          | AX.WAELZLG.DICHTRG | BEARING SEAL      | BAGUE-JOINT FOUL.   | ARO HERMET.AXIAL    | 125X79,5 H 2945                      |     |
| 8        | 230 9517  | 2          | FILLENKUGELLAGER   | BALL BEARING      | ROUL RAINURE BILLE  | COJ.BOLAS FIJO      |                                      | 01  |
| 9        | 230 2258  | 2          | SCHEIBE            | DISC/PANE/PLATE   | RONDELLE/DISQUE     | DISCO/CRISTAL/PLAT  |                                      |     |
| 10       | 110 7866  | 2          | SICHERUNGSRING     | CIRCLIP           | CIRCLIP             | CIRCLIP             | 125X4 DIN 472                        |     |
| 11       | 230 2259  | 2          | ABSTANDRING        | SPACER RING       | BAGUE ECARTEMENT    | ARO DISTANCIARIO    |                                      |     |
| 12       | 112 0677  | 2          | SICHERUNGSBLECH    | LOCKING PLATE     | TOLE DE SECURITE    | CHAPA SEGURIDAD     | A 70DIN70952                         |     |
| 13       | 116 7169  | 2          | NUTMUTTER          | GROOVED NUT       | ECROU RAINURE       | TUERCA RANURADA     | M 70X1,5H 2174                       |     |
| 15       | 111 2538  | 16         | SECHSKANTSCHRAUBE  | HEX.BOLT          | VIS 6 PANS          | TORNILLO HEXAGONAL  | M12X 35 DIN 933-M 8.8 A4C            |     |
| 25       | 116 8225  | 2          | KEGELSCHMIERNIPPEL | LUBE FITTING      | GRAISSEUR CONIQUE   | ENGRASADOR CONICO   | SA 8H 3360                           | 01  |
| 26       | 111 8693  | 2          | DICHTRING          | WASHER            | BAGUE D'ETANCHEITE  | ANILLO DE JUNTA     | A 14 X 20 DIN 7603-CU                |     |
| 27       | 112 2351  | 2          | VERSCHLUSSSCHRAUBE | SCREW PLUG        | BOUCHON FILETE      | TAPON ROSCADO       | M14X1,5 DIN 910-M 8.8                |     |
| 28       | 339 2268  | 12         | SCHRAUBE           | SCREW/BOLT        | VIS/BOULON          | TORNILLO            | 1455-27-02.18                        |     |
| 29       | 112 3546  | 12         | KUGELBANDMUTTER    | SHOULDER NUT      | ECROU COLLET SPHER. | TUERCA COLLAR.ESFER | A18 DIN74361-6S VZKC                 |     |
| 40       | 237 2170  | 2          | RADIAL DICHTRING   | RADIAL SEAL       | BAGUE-JOINT RADIAL  | ANIL.JUNTA RADIAL   |                                      | 01  |
| 44       | 237 8908  | 4          | ABSTANDSCHEIBE     | SPACER WASHER     | RONDELLE ECARTEM    | ARANDELA DISTANC.   |                                      |     |
| 45       | 111 1888  | 4          | SECHSKANTSCHRAUBE  | HEX.BOLT          | VIS 6 PANS          | TORNILLO HEXAGONAL  | M16X70 DIN 931-M8.8-A4C              |     |
| 46       | 111 2687  | 8          | SECHSKANTSCHRAUBE  | HEX.BOLT          | VIS 6 PANS          | TORNILLO HEXAGONAL  | M16X 40 DIN 933-M 8.8 A4C            |     |
| 47       | 111 2701  | 4          | SECHSKANTSCHRAUBE  | HEX.BOLT          | VIS 6 PANS          | TORNILLO HEXAGONAL  | M16X55 DIN 933-M8.8-A4C              |     |
| 48       | 111 2658  | 16         | SECHSKANTMUTTER    | HEX.NUT           | ECROU 6 PANS        | TUERCA HEXAGONAL    | M12 DIN 934-M8-A4C                   |     |
| 49       | 237 8681  | 16         | ZYLINDERSCHRAUBE   | CHEESE-HEAD SCREW | VIS TETE CYLINDR.   | TORN.CBZA.CILIND.   |                                      |     |
| 53       | 237 8919  | 1          | TRAGROHR           | SUPPORT TUBE      | TROMPETTE           | TROMPETA EJE        | B195, LINKS                          |     |

| Bild Nr. | Teile-Nr. | Stück-Zahl | Deutsch  | English      | Français       | Español            | Nummer/Bemerkung                        | ETK |
|----------|-----------|------------|----------|--------------|----------------|--------------------|---|-----|
| 54       | 237 5938  | 1          | TRAGROHR | SUPPORT TUBE | TROMPETTE      | TROMPETA EJE       | B267, RECHTS                            |     |
| 55       | 237 8923  | 1          | TRAGROHR | SUPPORT TUBE | TROMPETTE      | TROMPETA EJE       | B267, RECHTS<br>BOG9, ALLRADAUSFUEHRUNG |     |
| 58       | 237 8924  | 2          | GEHAUSE  | HOUSING/CASE | CARTER/BOITIER | CAJA/BLOQUE/CUERPO |   |     |

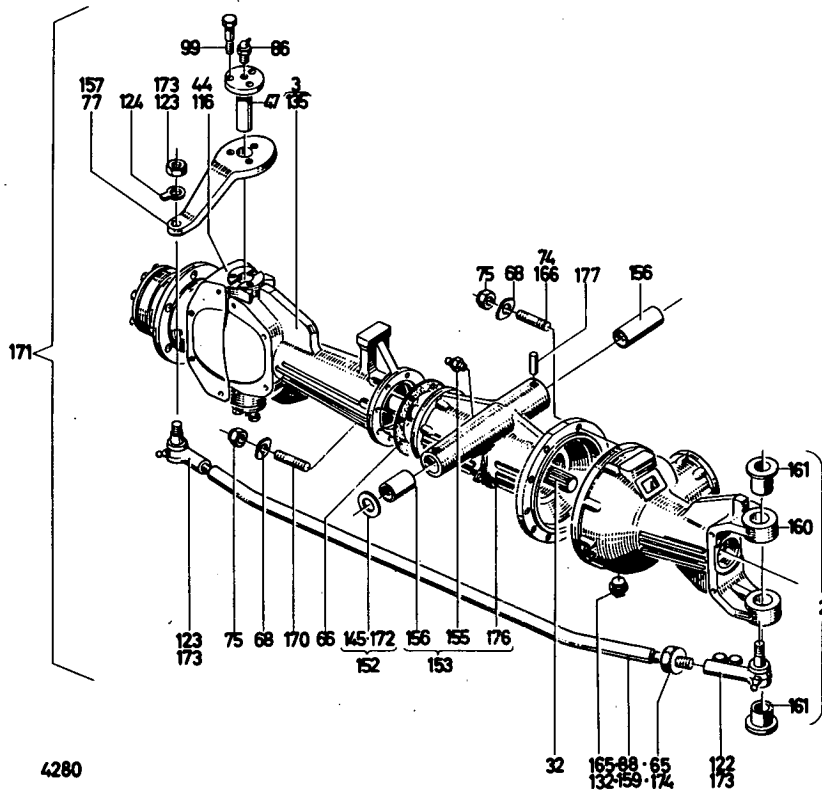

4280

53/74

171

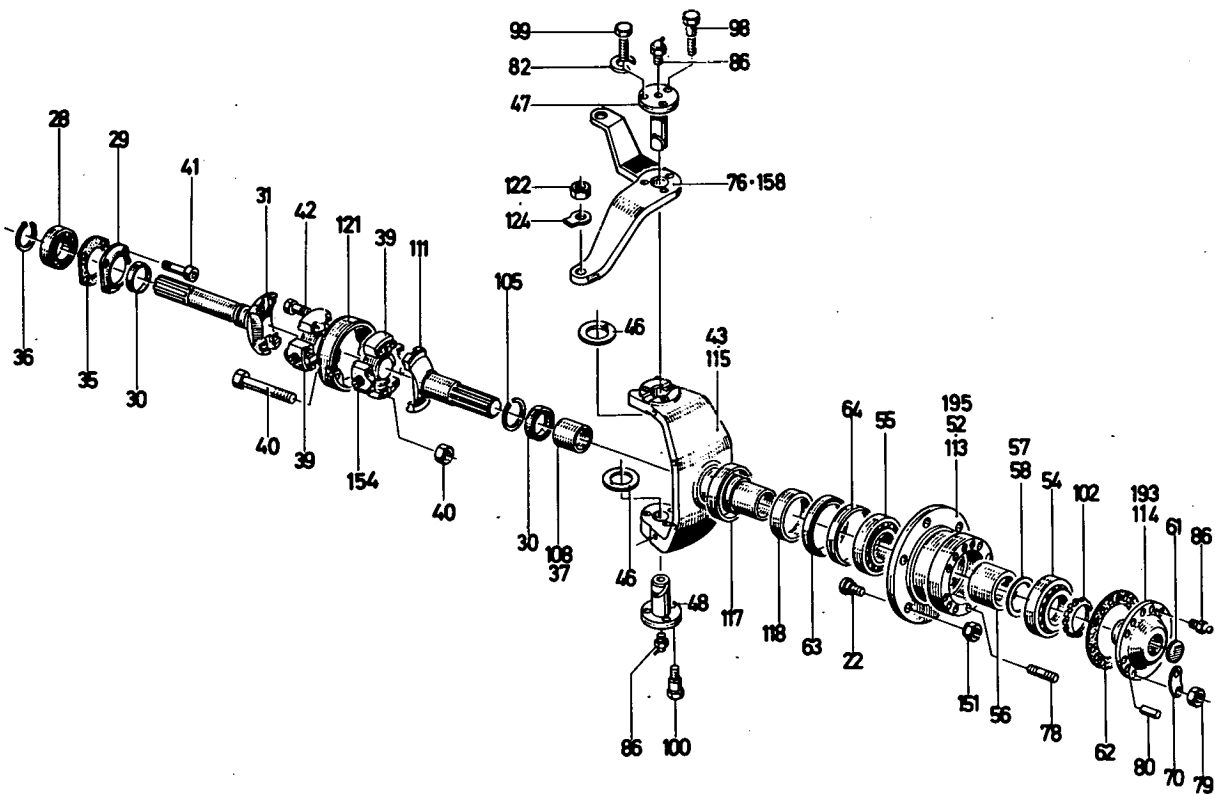

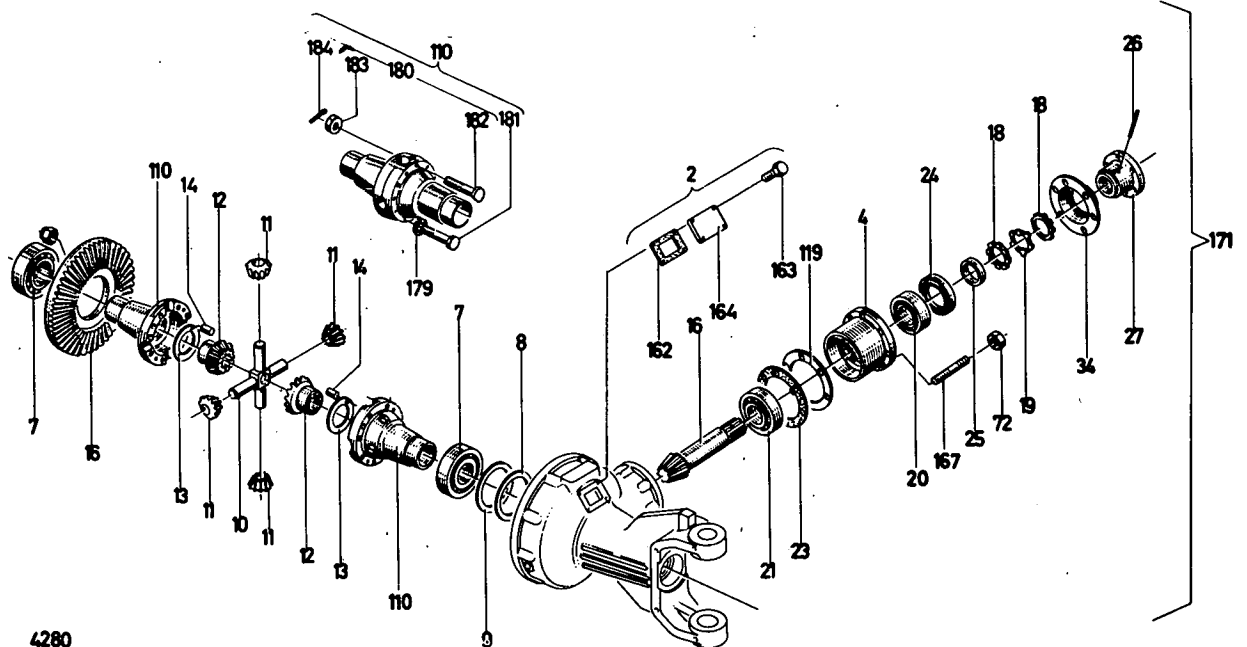

4280

1005-28 500 4280

| Bild Nr. | Teile-Nr. | Stück-Zahl | Deutsch            | Englsh             | Français           | Español            | Nummer/Bemerkung      | ETK |
|----------|-----------|------------|--------------------|--------------------|--------------------|--------------------|-----------------------|-----|
| 2        | 231 5984  | 1          | ACHSBRUECKE        | AXLE BRACKET       | PONT ESSIEU        | PUENTE EJE         | B348, VORN-LINKS      |     |
| 3        | 231 5982  | 1          | ACHSBRUECKE        | AXLE BRACKET       | PONT ESSIEU        | PUENTE EJE         | B349, VORN-RECHTS     |     |
| 4        | 231 1124  | 1          | LAGERGEHÄUSE       | BEARING HOUSING    | BOITIER DE PALIER  | CAJA SOPORTE       |                       |     |
| 7        | 111 0005  | 2          | KEGELROLLENLAGER   | TAP.ROLLER BEARING | ROULEM A ROUL CÓN  | COJ.RODIL.CONICOS  | 32212 DIN 720         | 01  |
| 8        | 231 1154  | 1          | BEILAGE            | SHIM               | CALE               | SUPLEMENTO         |                       |     |
| 9        | 231 1151  | 2          | BEILAGE            | SHIM               | CALE               | SUPLEMENTO         |                       |     |
| 10       | 231 1196  | 1          | KREUZZAPFEN        | SPIDER             | TENON EN CROIX     | MUNON CRUCETA      |                       |     |
| 11       | 231 1148  | 4          | KEGELRAD           | BEVEL GEAR         | ENGREN CONIQUE     | RUEDA CONICA       | Z=10                  |     |
| 12       | 231 1141  | 2          | KEGELRAD           | BEVEL GEAR         | ENGREN CONIQUE     | RUEDA CONICA       | Z=16                  |     |
| 13       | 237 8939  | 2          | ANLAUFSCHEIBE      | STOP WASHER        | DISQUE BUTEE       | ARANDELA TOPE      |                       |     |
| 14       | 231 1180  | 2          | ZYLINDERSTIFT      | PARALLEL PIN       | GOUPILLE CYLINDR.  | PERNO CILINDRICO   |                       |     |
| 16       | 231 2293  | 1          | KEGELRAD           | BEVEL GEAR         | ENGREN CONIQUE     | RUEDA CONICA       |                       |     |
| 18       | 112 0610  | 2          | NUTMUTTER          | GROOVED NUT        | ECROU RAINURE      | TUERCA RANURADA    | M 42X1,5 DIN70852-M8G | 01  |
| 19       | 231 1166  | 1          | SICHERUNGSBLECH    | LOCKING PLATE      | TOLE DE SECURITE   | CHAPA SEGURIDAD    |                       | 01  |
| 20       | 110 1909  | 1          | KEGELROLLENLAGER   | TAP.ROLLER BEARING | ROULEM A ROUL CON  | COJ.RODIL.CONICOS  | 32209 DIN 720         | 01  |
| 21       | 110 9981  | 1          | KEGELROLLENLAGER   | TAP.ROLLER BEARING | ROULEM A ROUL CON  | COJ.RODIL.CONICOS  | 30309 DIN 720         | 01  |
| 22       | 231 1164  | 12         | RADBEFESTIG.BOLZEN | WHEEL PIN          | BOULON FIX DE ROUE | BULON FIJAC.RUEDA  |                       |     |
| 23       | 231 1195  | 1          | BEILAGE            | SHIM               | CALE               | SUPLEMENTO         |                       |     |
| 24       | 231 1118  | 1          | DICHTRING          | WASHER             | BAGUE D'ETANCHEITE | ANILLO DE JUNTA    |                       | 01  |
| 25       | 231 1171  | 1          | ABSTANDRING        | SPACER RING        | BAGUE ECARTEMENT   | ARO DISTANCIARIO   |                       |     |
| 26       | 231 1173  | 1          | BOLZEN             | PIN/BOLT/STUD      | BOULON/AXE         | BULON              |                       |     |
| 27       | 231 1149  | 1          | ANTRIEBSFLANSCH    | DRIVE FLANGE       | BRIDE DE COMMANDE  | BRIDA ACCIONAMIENT |                       |     |
| 28       | 110 8981  | 2          | RILLENKUGELLAGER   | BALL BEARING       | ROUL RAINURE BILLE | COJ.BOLAS FIJO     | 6009 DIN 625          |     |



| Bld Nr. | Teile-Nr. | Stück-Zahl | Deutsch           | English            | Français           | Español            | Nummer/Bemerkung  | ETK |
|---------|-----------|------------|-------------------|--------------------|--------------------|--------------------|---|-----|
| 29      | 231 1194  | 2          | FLANSCH           | FLANGE             | BRIDE/COLLET       | BRIDA              |   |     |
| 30      | 231 1160  | 4          | DICHTRING         | WASHER             | BAGUE D'ETANCHEITE | ANILLO DE JUNTA    |   | 01  |
| 31      | 231 1140  | 1          | GELENKWELLE       | JOINT SHAFT        | ARBRE A CARDAN     | EJE ARTICULADO     | B195, LINKS   |     |
| 32      | 231 1139  | 1          | GELENKWELLE       | JOINT SHAFT        | ARBRE A CARDAN     | EJE ARTICULADO     | B267, RECHTS  |     |
| 34      | 231 1147  | 1          | SCHUTZKAPPE       | CAP                | CAPUCHON PROTECT   | SCMBRERETE PROTEC. |   |     |
| 35      | 231 1155  | 2          | DICHTUNG          | GASKET             | GARNITURE/JOINT    | JUNTA              |   | 01  |
| 36      | 110 7760  | 2          | SICHERUNGSRING    | CIRCLIP            | CIRCLIP            | CIRCLIP            | 45X1,75 DIN 471   |     |
| 37      | 231 1157  | 2          | BUCHSE            | BUSH               | DOUILLE            | CASQUILLO          | BC25, BIS ACHSEN-NO.1252<br>B002, AB ACHSEN-NO.1253 POS108                          |     |
| 39      | 231 1144  | 4          | KREUZGELENK       | UNIVERSAL JOINT    | JOINT A CROISILLON | ARTICULAC.CRUCETA  |   |     |
| 40      | 231 1190  | 8          | SECHSKANTSCHRAUBE | HEX.BOLT           | VIS 6 PANS         | TORNILLO HEXAGONAL |   |     |
| 41      | 231 1163  | 8          | ZYLINDER-SCHRAUBE | CHEESE-HEAD SCREW  | VIS TETE CYLINDR.  | TORN.CBZA.CILIND.  |   |     |
| 42      | 231 1184  | 16         | SECHSKANTSCHRAUBE | HEX.BOLT           | VIS 6 PANS         | TORNILLO HEXAGONAL |   |     |
| 43      | 231 1127  | 1          | NABENTRAEGER      | HUB CARRIER        | SUPPORT DE MOYEU   | PORTA-CUBO         | B195, LINKS<br>B025, BIS ACHSEN-NO.1252<br>B002, AB ACHSEN-NO.1253-1710<br>POS.950  |     |
| 44      | 231 1128  | 1          | NABENTRAEGER      | HUB CARRIER        | SUPPORT DE MOYEU   | PORTA-CUBO         | B267, RECHTS<br>B025, BIS ACHSEN-NO.1252<br>B002, AB ACHSEN-NO.1253-1710<br>POS.951 |     |
| 46      | 231 1156  | 4          | SCHLEIFE          | DISC/PANE/PLATE    | RONDELLE/DISQUE    | DISCO/CRISTAL/PLAT |   |     |
| 47      | 231 1197  | 2          | LAGERBOLZEN       | PIVOT PIN          | AXE SUPPORT        | BULON SOPORTE      | B242, OBEN  |     |
| 48      | 231 1199  | 2          | LAGERBOLZEN       | PIVOT PIN          | AXE SUPPORT        | BULON SOPORTE      | B324, UNTEN   |     |
| 52      | 231 1131  | 2          | NABE              | HUB                | MOYEU              | CUBO               | B025, BIS ACHSEN-NO.1710<br>B002, AB ACHSEN-NO.1711 POS113                          |     |
| 54      | 110 9963  | 2          | KEGELPOLLENLAGER  | TAP.ROLLER BEARING | ROULEM A ROUL CON  | COJ.RODIL.CONICOS  | 30213 DIN 720   | 01  |
| 55      | 110 9964  | 2          | KEGELROLLENLAGER  | TAP.ROLLER BEARING | ROULEM A ROUL CON  | COJ.RODIL.CONICOS  | 30214 DIN 720   | 01  |
| 56      | 231 1203  | 2          | ABSTANDROHR       | SPACER TUBE        | TUBE ECARTEMENT    | TUBO DISTANCIARIO  |   |     |
| 57      | 231 1168  | 2          | BEILAGE           | SHIM               | CALE               | SUPLEMENTO         | A=0,5MM   |     |
| 58      | 231 1167  | 4          | BEILAGE           | SHIM               | CALE               | SUPLEMENTO         | A=0,2MM   |     |
| 61      | 231 1159  | 2          | DECKEL            | COVER              | COUVERCLE          | TAPA               |   |     |
| 62      | 231 1193  | 2          | DICHTUNG          | GASKET             | GARNITURE/JOINT    | JUNTA              |   | 01  |
| 63      | 231 1162  | 2          | DICHTRING         | WASHER             | BAGUE D'ETANCHEITE | ANILLO DE JUNTA    |   | 01  |
| 64      | 231 1161  | 2          | ABSTANDRING       | SPACER RING        | BAGUE ECARTEMENT   | ARO DISTANCIARIO   |   |     |
| 65      | 231 1178  | 2          | SECHSKANTMUTTER   | HEX.NUT            | ECROU 6 PANS       | TUERCA HEXAGJNAL   | B075, ERSETZT DURCH POS.174   |     |
| 66      | 231 1153  | 2          | DICHTUNG          | GASKET             | GARNITURE/JOINT    | JUNTA              |   | 01  |
| 68      | 110 6354  | 18         | SICHERUNGSBLECH   | LOCKING PLATE      | TOLE DE SECURITE   | CHAPA SEGURIDAD    | 13 DIN 93-ST VZKC   | 01  |
| 70      | 231 1170  | 6          | SICHERUNGSBLECH   | LOCKING PLATE      | TOLE DE SECURITE   | CHAPA SEGURIDAD    |   |     |
| 72      | 110 2659  | 6          | SECHSKANTMUTTER   | HEX.NUT            | ECROU 6 PANS       | TUERCA HEXAGJNAL   | M10 DIN 934-M 8 A4C   |     |
| 74      | 231 1179  | 1          | BOLZENSCHRAUBE    | STUD               | BOULON             | TOPN.VASTAGO       |   |     |
| 75      | 111 2870  | 18         | SECHSKANTMUTTER   | HEX.NUT            | ECROU 6 PANS       | TUERCA HEXAGONAL   | M12 X1,5 DIN 934-M10  | 03  |
| 76      | 231 1129  | 1          | LENKSPURHEBEL     | STEERING ARM       | LEV ATTAQUE FUSEE  | PALANCA BIELA ACOP | B041, BEI ERSTMALIGEN ERSATZ<br>POS.157-159,173+174MITLIEFERN                       |     |
| 77      | 231 1134  | 1          | LENKHEBEL         | STEERING ARM       | LEVIER DE DIRECTIO | PALANCA DIRECCION  | B041, BEI ERSTMALIGEN ERSATZ<br>POS.157-159,173+174MITLIEFERN                       |     |
| 78      | 231 1183  | 16         | STIFTSCHRAUBE     | STUD               | GOUJON             | ESPARRAGO          |   |     |
| 79      | 231 1174  | 16         | SECHSKANTMUTTER   | HEX.NUT            | ECROU 6 PANS       | TUERCA HEXAGJNAL   |   |     |
| 80      | 231 1177  | 10         | ZYLINDERSTIFT     | PARALLEL PIN       | GOUPILLE CYLINDR.  | PERNO CILINDRICO   |   |     |
| 82      | 110 2799  | 32         | FEDERRING         | SPRING LOCKWASHER  | RONDELLE GROUVER   | ARANDELA ELASTICA  | A 8 DIN 128 A4C   |     |

| Blz<br>Nr. | Teile-Nr. | Stück-<br>Zahl | Deutsch            | English         | Français              | Español             | Nummer/Bemerkung   | ETK |
|------------|-----------|----------------|--------------------|-----------------|-----------------------|---------------------|--|-----|
| 86         | 116 8226  | 6              | SCHMIERNIPPEL      | LUBE FITTING    | RACCORD GRAISSEUR     | NIPLE LUBRICACION   | SA10H 3360   | 01  |
| 88         | 231 1201  | 1              | SPURSTANGE         | TRACK ROD       | BARRE ACCOUPLEMENT    | BIELA ANCHO RODAD.  | BC41,BEI ERSTMALIGEN ERSATZ<br>POS.157-159,173+174MITLIEFERN |     |
| 98         | 111 1325  | 2              | SECHSKANTSCHRAUBE  | HEX.BOLT        | VIS 6 PANS            | TORNILLO HEXAGONAL  | M10X 65 DIN 931- 8.8-A4C                                     |     |
| 99         | 111 1315  | 4              | SECHSKANTSCHRAUBE  | HEX.BOLT        | VIS 6 PANS            | TORNILLO HEXAGONAL  | M10X 55 DIN 931- 8.8-A4C                                     |     |
| 100        | 111 1124  | 6              | SECHSKANTSCHRAUBE  | HEX.BOLT        | VIS 6 PANS            | TORNILLO HEXAGONAL  | M 8X 25 DIN 931-M 8.8 VZKC                                   |     |
| 102        | 231 6043  | 2              | NUTMUTTER          | GROOVED NUT     | ECROU RAINURE         | TUERCA RANURADA     |  | 01  |
| 105        | 110 7846  | 2              | SICHERUNGSRING     | CIRCLIP         | CIRCLIP               | CIRCLIP             | 6RX2,5 DIN 472   |     |
| 108        | 232 1981  | 2              | BUCHSE             | BUSH            | DOUILLE               | CASQUILLO           | BC01,AB ACHSEN-NO 1253<br>POS.37                             |     |
| 110        | 232 5551  | 1              | DIFFER.GEHAUESE    | DIFF.CASE       | CARTER DU DIFFER      | CAJA DIFERENCIAL    |  |     |
| 111        | 232 5790  | 2              | GELENKWELLE        | JOINT SHAFT     | ARBRE A CARDAN        | EJE ARTICULADO      |  |     |
| 113        | 232 5791  | 2              | NABE               | HUB             | MOYEU                 | CUBO                | 8001,AB ACHSEN-NO.1711-6808<br>8001,AB ACHSEN-NO.6809 POS195 |     |
| 114        | 232 5792  | 2              | FLANSCH            | FLANGE          | BRIDE/COLLET          | BRIDA               | 8025,BIS ACHSEN-NO 6808<br>8001,AB ACHSEN-NO 6809 POS193     |     |
| 115        | 232 5793  | 1              | NABENTRAEGER       | HUB CARRIER     | SUPPORT DE MOYEU      | PORTA-CUBO          | B195,LINKS   |     |
| 116        | 232 5794  | 1              | NABENTRAEGER       | HUB CARRIER     | SUPPORT DE MOYEU      | PORTA-CUBO          | B262,RECHTS  |     |
| 117        | 232 5795  | 2              | RING               | RING            | BAGUE/ANNEAU          | ANILLO              | B161,INNEN   | 01  |
| 118        | 232 5796  | 2              | RING               | RING            | BAGUE/ANNEAU          | ANILLO              | B013,AUSSEN  | 01  |
| 119        | 233 9257  | 1              | SCHEIBE            | DISC/PANE/PLATE | RONDELLE/DISQUE       | DISCO/CRISTAL/PLAT  |  |     |
| 121        | 237 2174  | 2              | TRAEGER            | SUPPORT/CARRIER | SUPPORT/POUTRE        | VIGA/SOPORTE        | B001,AB ACHSEN-NO 4074                                       |     |
| 122        | 237 2175  | 1              | KUGELGELENK        | BALL JOINT      | JOINT A ROTULE        | ARTICULAC.ESFERIC   | 8041,BEI ERSTMALIGEN ERSATZ<br>POS.173,157-159+174MITLIEFERN |     |
| 123        | 237 3524  | 1              | KUGELGELENK        | BALL JOINT      | JOINT A ROTULE        | ARTICULAC.ESFERIC   | 8041,BEI ERSTMALIGEN ERSATZ<br>POS.173,157-159+174MITLIEFERN |     |
| 124        | 110 6354  | 2              | SICHERUNGSBLECH    | LOCKING PLATE   | TOLE DE SECURITE      | CHAPA SEGURIDAD     | 13 DIN 93-ST VZKC<br>8027,BIS FAHRGESTELL-NO                 |     |
| 132        | 110 4151  | 2              | VERSCHLUSSSCHRAUBE | SCREW PLUG      | BOUCHON FILETE        | TAPON ROSCADO       | M20X1,5 DIN 906- 5.8   |     |
| 135        | 231 1121  | IP             | ACHSBRUECKE        | AXLE BRACKET    | PONT ESSIEU           | PUENTE EJE          | B367,ZU POS.3  |     |
| 145        | 233 0371  | 1              | SCHEIBE            | DISC/PANE/PLATE | RONDELLE/DISQUE       | DISCO/CRISTAL/PLAT  | D=14MM   |     |
| 151        | 110 1323  | 12             | KUGELBUNDMUTTER    | SHOULDER NUT    | ECROU COLLET SPHER    | TUERC.COLLAR.ESFER  | A18 DIN74361- 8G VZKC  |     |
| 152        | 233 0369  | SZ             | SCHEIBE            | DISC/PANE/PLATE | RONDELLE/DISQUE       | DISCO/CRISTAL/PLAT  |  |     |
| 153        | 231 6787  | 1              | LAGERGEHAUESE      | BEARING HOUSING | BOITIER DE PALIER     | CAJA SOPORTE        |  |     |
| 154        | 233 9345  | 8              | SCHMIERNIPPEL      | LUBE FITTING    | RACCORD GRAISSEUR     | NIPLE LUBRICACION   |  | 01  |
| 155        | 116 8226  | 1              | SCHMIERNIPPEL      | LUBE FITTING    | RACCORD GRAISSEUR     | NIPLE LUBRICACION   | SA10H 3360   | 01  |
| 156        | 231 5688  | 2              | BUCHSE             | BUSH            | DOUILLE               | CASQUILLO           |  |     |
| 157        | 237 8933  | 1              | LENKHEBEL          | STEERING ARM    | LEVIER DE DIRECTIO    | PALANCA DIRECCION   |  |     |
| 158        | 237 8935  | 1              | LENKSPURHEBEL      | STEERING ARM    | LEV ATTAQUE FUSEE     | PALANCA BIELA ACOPI |  |     |
| 159        | 237 8936  | 1              | SPURSTANGE         | TRACK ROD       | BARRE ACCOUPLEMENT    | BIELA ANCHO RODAD.  |  |     |
| 160        | 231 1120  | IP             | ACHSBRUECKE        | AXLE BRACKET    | PONT ESSIEU           | PUENTE EJE          | B367,ZU POS.2  |     |
| 161        | 232 5737  | 4              | LAGERBUCHSE        | BEARING BUSH    | BAGUE DE PALIER       | CASQU.COJINETE      |  |     |
| 162        | 231 1172  | 1              | DICHTUNG           | GASKET          | GARNITURE/JOINT       | JUNTA               |  |     |
| 163        | 111 2295  | 4              | SECHSKANTSCHRAUBE  | HEX.BOLT        | VIS 6 PANS            | TORNILLO HEXAGONAL  | M 8X 10 DIN 933- 8.8-A4C                                     |     |
| 164        | 231 1202  | 1              | ENTLUEFTUNGSVENTIL | BREATHER VALVE  | SOUP DEGAGEMENT D'AIR | VALV.PRGA.AIRE      |  |     |
| 165        | 231 1165  | 2              | VERSCHLUSSSCHRAUBE | SCREW PLUG      | BOUCHON FILETE        | TAPON ROSCADO       | 8025,BIS ACHSEN-NO.5529<br>8002,AB ACHSEN-NO.5530 POS132     |     |
| 166        | 231 1182  | 10             | STIFTSCHRAUBE      | STUD            | GOUJON                | ESPARRAGO           |  |     |
| 167        | 111 3477  |                | STIFTSCHRAUBE      | STUD            | GOUJON                | ESPARRAGO           | AM10 X 35 DIN 939- 8.8-PHOSPH                                |     |

| Bld<br>Nr. | Teile-Nr. | Stück-<br>Zahl | Deutsch           | English         | Français          | Español            | Nummer/Bemerkung               | ETK |
|------------|-----------|----------------|-------------------|-----------------|-------------------|--------------------|--------------------------------|-----|
| 170        | 231 1182  | 8              | STIFTSCHRAUBE     | STUD            | GOUJON            | ESPARRAGO          |                                |     |
| 171        | 237 8943  | 1              | TRIEBACHSE        | DRIVING AXLE    | ESSIEU MOTEUR     | EJE MOTRIZ         |                                |     |
| 172        | 233 0372  | 1              | SCHEIBE           | DISC/PANE/PLATE | RONDELLE/DISQUE   | DISCO/CRISTAL/PLAT | D=2 MM.                        |     |
| 173        | 237 8948  | 2              | KUGELGELENK       | BALL JOINT      | JOINT A ROTULE    | ARTICULAC.ESFERIC  |                                |     |
| 174        | 237 8938  | 2              | SECHSKANTMUTTER   | HEX.NUT         | ECROU 6 PANS      | TUERCA HEXAGONAL   |                                |     |
| 176        | 237 6770  | 1              | LAGERGEHAEUSE     | BEARING HOUSING | BOITIER DE PALIER | CAJA SOPORTE       |                                |     |
| 177        | 238 1587  | 2              | BOLZEN            | PIN/BOLT/STUD   | BOULON/AXE        | BULON              |                                |     |
| 180        | 231 1186  | 10             | SCHRAUBE          | SCREW/BOLT      | VIS/BOULON        | TORNILLO           |                                |     |
| 181        | 111 1060  | 2              | SECHSKANTSCHRAUBE | HEX.BOLT        | VIS 6 PANS        | TORNILLO HEXAGONAL | M 6 X 28 DIN 931- 8.8          |     |
| 182        | 231 1187  | 1P             | SCHRAUBE          | SCREW/BOLT      | VIS/BOULON        | TORNILLO           |                                |     |
| 183        | 231 1188  | 1P             | KRONENMUTTER      | CASTLE NUT      | ECROU CRENELE     | TUERCA CORONA      |                                |     |
| 184        | 110 6434  | 10             | SPLINT            | SPLIT PIN       | GOUILLE FENDUE    | PASADOR ALETAS     | 3 X 25DIN 94                   |     |
| 193        | 238 2022  | 2              | FLANSCH           | FLANGE          | BRIDE/COLLET      | BRIDA              | B247,OHNE POS.86               |     |
| 195        | 238 2025  | 2              | NABE              | HUB             | MOYEU             | CUBO               | B247,OHNE POS.86               |     |
| 950        | 232 2600  | 1              | TRAEGER           | SUPPORT/CARRIER | SUPPORT/POUTRE    | VIGA/SOPORTE       | B002,AB ACHSEN NO.1711 POS.115 |     |
| 951        | 232 2599  | 1              | TRAEGER           | SUPPDRT/CARRIER | SUPPORT/POUTRE    | VIGA/SOPORTE       | B002,AB ACHSEN NO.1711 POS.116 |     |

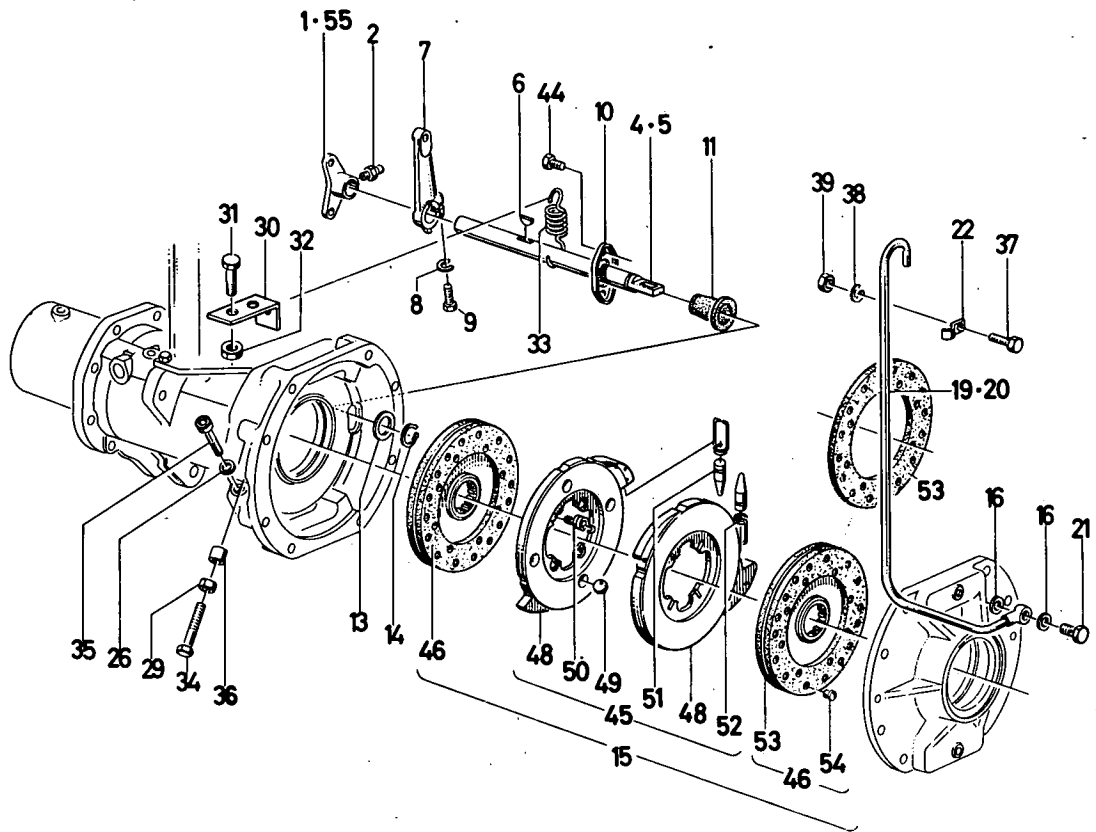

| Bild Nr. | Teile-Nr. | Stück-Zahl | Deutsch            | English           | Français            | Español            | 1446-30<br>Nummer/Bemerkung | 500 6488<br>ETK |
|----------|-----------|------------|--------------------|-------------------|---------------------|--------------------|-----------------------------|-----------------|
| 1        | 232 9511  | 2          | LAGERBOCK          | BRACKET           | CHEVALET SUPPORT    | CABALLETE SOPORTE  | 8027,815 FAHRGESTELL-NO.    |                 |
| 2        | 116 8225  | 2          | KEGELSCHMIERNIPPEL | LUBE FITTING      | GRAISSEUR CONIQUE   | ENGRASADOR CONICO  | SA 8H 3360                  | 01              |
| 4        | 232 6087  | 1          | WELLE              | SHAFT             | ARBRE               | EJE/ARBOL          | B267,RECHTS                 |                 |
| 5        | 232 6088  | 1          | WELLE              | SHAFT             | ARBRE               | EJE/ARBOL          | B195,LINKS                  |                 |
| 6        | ▲10 1503  | 2          | SCHEIBENFEDER      | WOODRUFF KEY      | CLAVETTE WOODRUFF   | CHAVETA MEDIA LUNA | 10 X13 DIN 6888             |                 |
| 7        | 232 2665  | 2          | HEBEL              | LEVER/ARM         | LEVIER              | PALANCA            |                             |                 |
| 8        | 110 2800  | 2          | FEDERRING          | SPRING LOCKWASHER | RONDELLE GROWER     | ARANDELA ELASTICA  | A10 DIN 128-A4C             |                 |
| 9        | 111 2439  | 2          | SECHSKANTSCHRAUBE  | HEX.BOLT          | VIS 6 PANS          | TORNILLO HEXAGONAL | M10X 35 DIN 933-M 8.8 A4C   |                 |
| 10       | 233 2674  | 2          | FLANSCH            | FLANGE            | BRIDE/COLLET        | BRIDA              |                             |                 |
| 11       | 232 6089  | 2          | MANSCHETTE         | SEAL/SLEEVE       | EMBOUTI/GARNITURE   | MANGUITO           |                             | 01              |
| 13       | 233 2675  | 2          | SCHEIBE            | DISC/PANE/PLATE   | RONDELLE/DISQUE     | DISCO/CRISTAL/PLAT |                             |                 |
| 14       | 110 7751  | 2          | SICHERUNGSRING     | CIRCLIP           | CIRCLIP             | CIRCLIP            | 36X1,75DIN 471              |                 |
| 15       | 233 2680  | 2          | SCHEIBENBREMSE     | DISC BRAKE        | FREIN A DISQUE      | FRENO DE DISCO     |                             |                 |
| 16       | 111 8693  | 4          | DICHTRING          | WASHER            | BAGUE D'ETANCHEITE  | ANILLO DE JUNTA    | A 14 X 20 DIN 7603-CU       |                 |
| 19       | 233 2678  | 1          | ENTLUEFTUNGSROHR   | BREATHER PIPE     | TUBE DE DESAERAGE   | TUBO PRG.AIRE      | B267,RECHTS                 |                 |
| 20       | 233 2679  | 1          | ROHR               | PIPE/TUBE         | TUBE/TUYAU          | TUBO               | B195,LINKS                  |                 |
| 21       | 111 9246  | 2          | HOHLSCHRAUBE       | BANJO BOLT        | VIS BANJO           | TORNILLO RACOR     | A 8 DIN 7623                |                 |
| 22       | 112 1255  | 2          | ROHRSCHELLE        | PIPE CLIP         | COLLIER PR TUBES    | ABRAZADERA DE TUBO | 1X10 DIN 72571 VZKC         |                 |
| 26       | 111 8707  | 4          | DICHTRING          | WASHER            | BAGUE D'ETANCHEITE  | ANILLO DE JUNTA    | A 16 X 22 DIN 7603-CU       |                 |
| 29       | 111 2886  | 2          | SECHSKANTMUTTER    | HEX.NUT           | ECROU 6 PANS        | TUERCA HEXAGONAL   | M16 DIN 934-M8-A4C          |                 |
| 30       | 233 9837  | 2          | HALTER             | RETAINER          | SUPPORT/PORTEQUITIL | SOPORTE            |                             |                 |
| 31       | 111 2326  | 4          | SECHSKANTSCHRAUBE  | HEX.BOLT          | VIS 6 PANS          | TORNILLO HEXAGONAL | M8X22 DIN 933-8.8-A4C       |                 |
| 32       | 111 2824  | 4          | SECHSKANTMUTTER    | HEX.NUT           | ECROU 6 PANS        | TUERCA HEXAGONAL   | M8 DIN 934-M8-A4C           |                 |

| Bild<br>Nr. | Teile-Nr.           | Stück-<br>Zahl | Deutsch           | English           | Français          | Español            | 1446-30 500 6488          |     |
|-------------|---------------------|----------------|-------------------|-------------------|-------------------|--------------------|---------------------------|-----|
|             |                     |                |                   |                   |                   |                    | Nummer/Bemerkung          | ETK |
| 33          | 233 9818            | 2              | ZUGFEDER          | DRAW SPRING       | RESSORT TRACTION  | RESORTE TRACCION   |                           | 01  |
| 34          | 110 4687            | 2              | SECHSKANTSCHRAUBE | HEX.BOLT          | VIS 6 PANS        | TORNILLO HEXAGONAL | BM 16X140 DIN 561-5.8 A4C |     |
| 35          | 111 0855            | 2              | ZYLINDERSCHRAUBE  | CHEESE-HEAD SCREW | VIS TETE CYLINDR. | TORN.CBZA.CILIND.  | M 16X70 DIN 912-10.9 A4C  |     |
| 36          | 237 0830            | 2              | ABSTANDRING       | SPACER RING       | BAGUE ECARTEMENT  | ARO DISTANCIARIO   |                           |     |
| 37          | 111 2179            | 2              | SECHSKANTSCHRAUBE | HEX.BOLT          | VIS 6 PANS        | TORNILLO HEXAGONAL | M 4X 10 DIN 933- 8.8-A4C  |     |
| 38          | 110 2795            | 2              | FEDERRING         | SPRING LOCKWASHER | RONDELLE GROWER   | ARANDELA ELASTICA  | A 4 DIN 128-A4C           |     |
| 39          | 111 2796            | 2              | SECHSKANTMUTTER   | HEX.NUT           | ECROU 6 PANS      | TUERCA HEXAGONAL   | M 4 DIN 934-M 8 A4C       |     |
| 44          | 110 3316            | 4              | SECHSKANTSCHRAUBE | HEX.BOLT          | VIS 6 PANS        | TORNILLO HEXAGONAL | M 6X 16 DIN 933- 8.8-A4C  |     |
| 45          | 233 2270            | 1              | SCHEIBE           | DISC/PANE/PLATE   | RONDELLE/DISQUE   | DISCO/CRISTAL/PLAT |                           |     |
| 46          | <del>233 2771</del> | 2              | BELAGSCHEIBE      | LINING            | DISQUE-GARNITURE  | PLATO DE FORRO     | 4337094                   | 01  |
| 48          | 237 3746            | 2              | SCHEIBE           | DISC/PANE/PLATE   | RONDELLE/DISQUE   | DISCO/CRISTAL/PLAT |                           |     |
| 49          | 230 5008            | 6              | KUGEL             | BALL              | BILLE/BOULE       | BOLA               |                           | 01  |
| 50          | 230 5009            | 4              | ZUGFEDER          | DRAW SPRING       | RESSORT TRACTION  | RESORTE TRACCION   |                           | 01  |
| 51          | 230 5011            | 2              | STOESSEL          | TAPPET/PLUNGER    | POUSSOIR          | TAQUE/EMPUJADOR    |                           | 01  |
| 52          | 230 5010            | 2              | FEDER             | SPRING            | RESSORT           | RESORTE/BALLESTA   |                           | 01  |
| 53          | 233 3817            | 2              | BELAG             | FACING/LINING     | GARNITURE         | FORRO              |                           | 01  |
| 54          | 233 3818            | 24             | NIET              | RIVET             | RIVET             | REMACHE            |                           | 01  |
| 55          | 238 4799            | 2              | LAGERBOCK         | BRACKET           | CHEVALET SUPPORT  | CABALLETE SOPORTE  | 8003,AB FAHRGESTELL-NO.   |     |

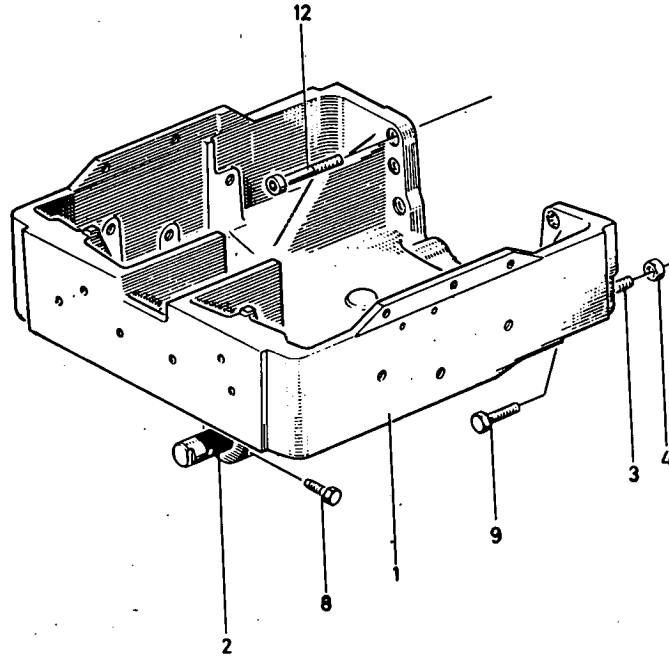

| Bld. Nr. | Teile-Nr. | Stück-Zahl | Deutsch           | English           | Français          | Español            | 1003-32<br>Nummer/Bemerkung | 500 6029<br>ETK |
|----------|-----------|------------|-------------------|-------------------|-------------------|--------------------|-----------------------------|-----------------|
| 1        | 233 4037  | 1          | ACHSLAGERBOCK     | AXLE BRACKET      | BERCEAU ESSIEU    | CABALLETE P.EJE    |                             |                 |
| 2        | 230 1515  | 1          | BOLZEN            | PIN/BOLT/STUD     | BOULON/AXE        | BULON              |                             |                 |
| 3        | 110 1007  | 2          | SKT.PASSSCHRAUBE  | FITTED BOLT       | VIS AJUST 6 PANS  | TORN.HEX.CALIBR.   | M18X2X85 DIN 609-M8.8-A4C   |                 |
| 4        | 111 2908  | 2          | SECHSKANTMUTTER   | HEX.NUT           | ECROU 6 PANS      | TUERCA HEXAGONAL   | M18X2 DIN 934-M8-VZKC       |                 |
| 8        | 230 9386  | 1          | KLEMMSCHRAUBE     | CLAMPING SCREW    | VIS DE SERRAGE    | TORNILLO APRIETD   |                             |                 |
| 9        | 110 1923  | 2          | SECHSKANTSCHRAUBE | HEX.BOLT          | VIS 6 PANS        | TORNILLO HEXAGONAL | M16X95 DIN 931-M10.9 A4C    |                 |
| 12       | 110 2298  | 4          | ZYLINDERSCHRAUBE  | CHEESE-HEAD SCREW | VIS TETE CYLINDR. | TORN.CBZA.CILIND.  | M 14X110 DIN 912-10.9-A4C   |                 |

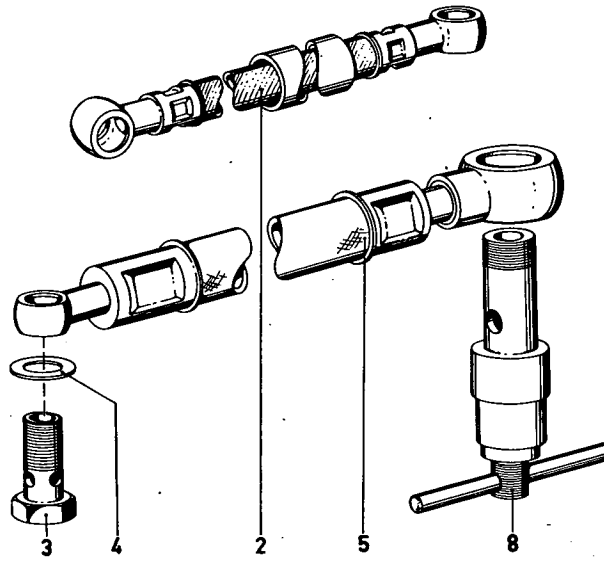

| Bild Nr. | Teile-Nr. | Stück-Zahl | Deutsch           | English    | Français           | Español            | 1001-42<br>Nummer/Bemerkung | 500 5218<br>ETK |
|----------|-----------|------------|-------------------|------------|--------------------|--------------------|-----------------------------|-----------------|
| 2        | 338 8595  | 1          | KRAFTSTOFFLEITUNG | FUEL LINE  | CONDUITE COMBUST   | TUBERIA COMBUSTIBL | 1135-42-08.10               | 01              |
| 3        | 111 9246  | 2          | HOHL SCHRAUBE     | BANJO BOLT | VIS BANJO          | TORNILLO RACOR     | A 8 DIN 7623                |                 |
| 4        | 111 8688  | 4          | DICHTRING         | WASHER     | BAGUE D'ETANCHEITE | ANILLO DE JUNTA    | A 14 X 18 DIN 7603-CU       |                 |
| 5        | 231 1696  | 1          | SCHLAUCHLEITUNG   | HOSE       | CONDUITE FLEXIBLE  | MANGUERA           |                             | 01              |
| 8        | 231 1411  | 1          | HOHL SCHRAUBE     | BANJO BOLT | VIS BANJO          | TORNILLO RACOR     |                             |                 |

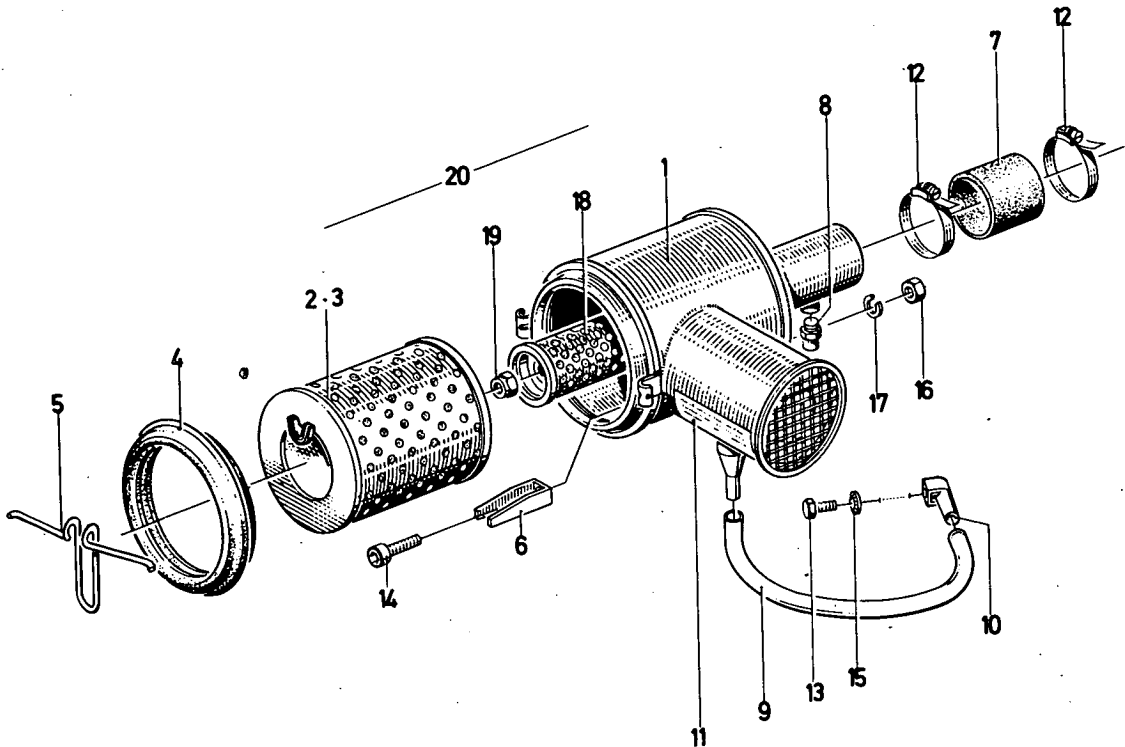

1002-43 500 6416

| Bild Nr. | Teil-Nr.            | Stück-Zahl | Deutsch           | English           | Français           | Español            | Nummer/Bemerkung         | ETK |
|----------|---------------------|------------|-------------------|-------------------|--------------------|--------------------|--------------------------|-----|
| 1        | 237 4936            | 1          | FILTERGEHÄUSE     | BODY              | CORPS DE FILTRE    | CAJA FILTRO        |                          |     |
| 2        | <del>233-9812</del> | 1          | FILTERPATRONE     | CARTRIDGE         | CARTOUCHE FILTRANT | CARTUCHO FILTRO    | 8355, WAHLWEISE POS.3    | 01  |
| 3        | 233 9813            | 1          | FILTERPATRONE     | CARTRIDGE         | CARTOUCHE FILTRANT | CARTUCHO FILTRO    | 8355, WAHLWEISE POS.2    | 01  |
| 4        | 237 2778            | 1          | DICHTUNG          | GASKET            | GARNITURE/JOINT    | JUNTA              |                          | 01  |
| 5        | 237 4896            | 1          | FEDERKNEBEL       | CLIP              | POIGNEE A RESSORT  | MULETILLA RESORTE  |                          |     |
| 6        | 232 2921            | 3          | FUEHRUNGSBUEGEL   | GUIDE             | ETRIER DE GUIDAGE  | ESTRIBO GUIA       |                          |     |
| 7        | 116 5397            | 1          | GUHMUFFE          | RUBBER SLEEVE     | MANCHON CADUTCHOUC | MANGUITO CAUCHO    | A 70X 80X 65H 650        | 01  |
| 8        | 113 0548            | 1          | VERSCHLUSSMUTTER  | CAP NUT           | ECROU BORGNE       | TUERCA DE CIERRE   | M10X1 DIN 7605 A4C       |     |
| 9        | 231 5967            | 1          | SCHLAUCH          | HOSE              | FLEXIBLE           | MANGUERA           |                          |     |
| 10       | 231 5968            | 1          | MUNDSTUECK        | MOUTHPIECE        | BEC/EMBOUCHURE     | BOQUILLA           |                          |     |
| 11       | 121 1590            | 1          | BEDIENUNGSSCHILD  | INSTRUCTION PLATE | PLAQUE INSTRUCTNS  | ROTULO SERVICIO    | 4 308 A 656              |     |
| 12       | 116 6417            | 2          | SCHLAUCHSCHELLE   | HOSE CLIP         | COLLIER SERRAGE    | ABRAZADERA MANGUER | S 80 X15 H 735           |     |
| 13       | 112 3746            | 1          | SECHSKANTSCHRAUBE | HEX.BOLT          | VIS 6 PANS         | TORNILLO HEXAGONAL | M 5X 10 DIN 933- 8.8-A4C |     |
| 14       | 110 2193            | 3          | ZYLINDERSCHRAUBE  | CHEESE-HEAD SCREW | VIS TETE CYLINDR.  | TORN.CBZA.CILIND.  | M 8X 16DIN 912- 8.8-A4C  |     |
| 15       | 116 7193            | 1          | SICHERUNGSSCHEIBE | LOCKING WASHER    | RONDÉLLE SECURITE  | ARANDELA SEGURIDAD | S H 2203                 |     |
| 16       | 111 2824            | 3          | SECHSKANTMUTTER   | HEX.NUT           | ECROU 6 PANS       | TUERCA HEXAGONAL   | M 8 DIN 934-M 8 A4C      |     |
| 17       | 110 2799            | 3          | FEDERRING         | SPRING LOCKWASHER | RONDÉLLE GROVER    | ARANDELA ELASTICA  | A 8 DIN 128 A4C          |     |
| 18       | 237 9161            | 1          | PATRONE           | CARTRIDGE         | CARTOUCHE          | CARTUCHO           |                          |     |
| 19       | 116 7193            | 1          | SECHSKANTMUTTER   | HEX.NUT           | ECROU 6 PANS       | TUERCA HEXAGONAL   | M8H 2125                 |     |
| 20       | 237 5053            | 1          | LUFILTER          | AIR CLEANER       | FILTRE A AIR       | FILTRO AIRE        |                          |     |





Auspufftopf  
Exhaust Silencer  
Pot d' Echappement  
Silencioso Escape

1001-44 501 7011

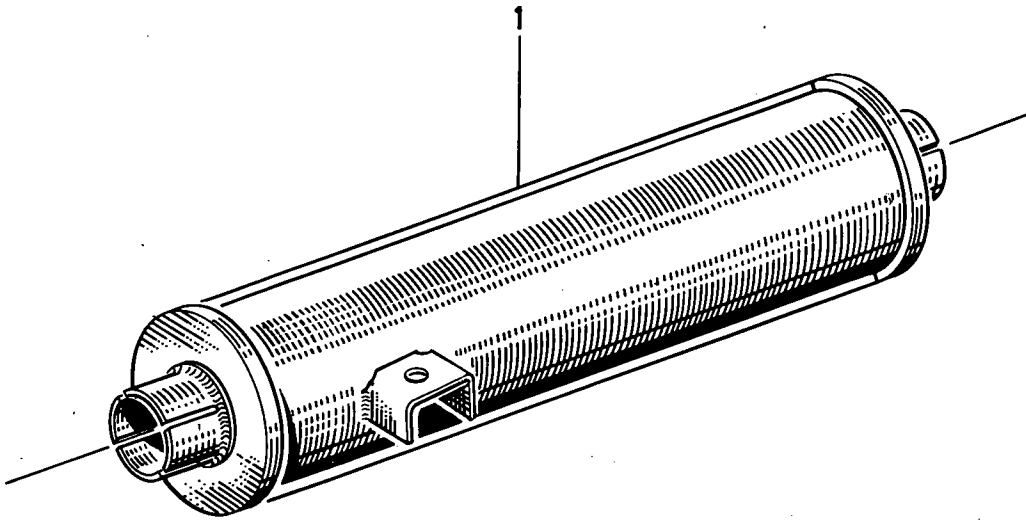

| Bild Nr. | Teile-Nr.                      | Stück-Zahl | Deutsch     | English          | Français          | Español           | 1001-44 501 7011<br>Nummer/Bemerkung | ETK |
|----------|--------------------------------|------------|-------------|------------------|-------------------|-------------------|--------------------------------------|-----|
| 1        | <del>237 5154</del><br>2320894 | 1          | AUSPUFFTOPF | EXHAUST SILENCER | POT D'ECHAPPEMENT | SILENCIOSO ESCAPE |                                      |     |

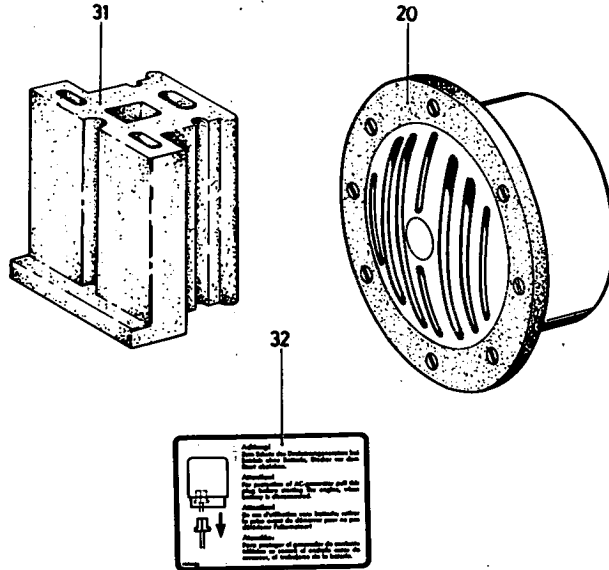

| Bild<br>Nr. | Teile-Nr. | Stück-<br>Zahl |                 |               |                    |                    | 1001-49          | 500 5233 | ETK |
|-------------|-----------|----------------|-----------------|---------------|--------------------|--------------------|------------------|----------|-----|
|             |           |                | Deutsch         | English       | Français           | Español            | Nummer/Bemerkung |          |     |
| 20          | 116 9304  | 1              | HORN            | HORN          | KLAXON             | BOCINA             | 100 X12 H 7650   |          |     |
| 31          | 116 1165  | 2              | FLACHSTECKDOSE  | FLAT SOCKET   | BOITE FICHE PLATE  | CAJA ENCHUFE PLANO | G1 H 7642        |          |     |
| 32          | 121 2263  | 1              | AUSCHRIFTSCHILD | MARKING PLATE | PLAQUE D'INSCRIPT. | ROTULO             |                  |          |     |

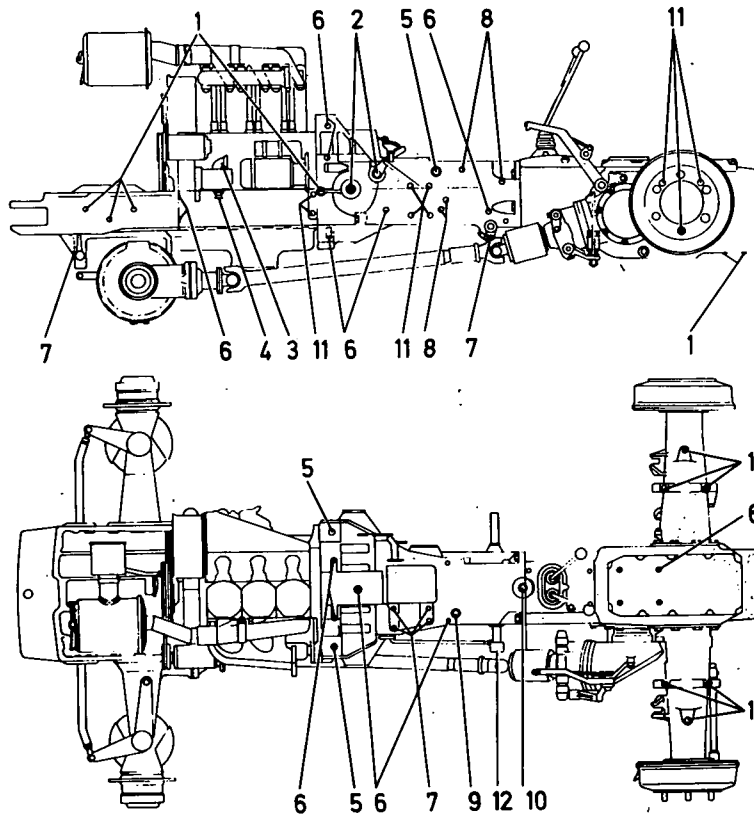

| Bld. Nr. | Teile-Nr. | Stück-Zahl | Deutsch           | English | Français | Español         | 1003-57 500 5376<br>Nummer/Bemerkung | ETK |
|----------|-----------|------------|-------------------|---------|----------|-----------------|--------------------------------------|-----|
| 1        | 116 7316  | 22         | VERSCHLUSSSTOPFEN | NIPPLE  | BOUCHON  | TAPON OBTURADOR | A14 H 2873                           |     |
| 2        | 116 7333  | 3          | VERSCHLUSSSTOPFEN | NIPPLE  | BOUCHON  | TAPON OBTURADOR | A41 H 2873                           |     |
| 3        | 116 7331  | 1          | VERSCHLUSSSTOPFEN | NIPPLE  | BOUCHON  | TAPON OBTURADOR | A32 H2873                            |     |
| 4        | 116 7328  | 1          | VERSCHLUSSSTOPFEN | NIPPLE  | BOUCHON  | TAPON OBTURADOR | A24,5X25H2873                        |     |
| 5        | 116 1302  | 4          | VERSCHLUSSSTOPFEN | NIPPLE  | BOUCHON  | TAPON OBTURADOR | A25,5 H 2873                         |     |
| 6        | 116 7308  | 25         | VERSCHLUSSSTOPFEN | NIPPLE  | BOUCHON  | TAPON OBTURADOR | A7 H 2873                            |     |
| 7        | 116 7315  | 7          | VERSCHLUSSSTOPFEN | NIPPLE  | BOUCHON  | TAPON OBTURADOR | A12,5 H 2873                         |     |
| 8        | 116 7311  | 4          | VERSCHLUSSSTOPFEN | NIPPLE  | BOUCHON  | TAPON OBTURADOR | A 9 H 2873                           |     |
| 9        | 116 7326  | 1          | VERSCHLUSSSTOPFEN | NIPPLE  | BOUCHON  | TAPON OBTURADOR | A22,5 H 2873                         |     |
| 10       | 116 7319  | 1          | VERSCHLUSSSTOPFEN | NIPPLE  | BOUCHON  | TAPON OBTURADOR | A16,5 H 2873                         |     |
| 11       | 116 7313  | 18         | VERSCHLUSSSTOPFEN | NIPPLE  | BOUCHON  | TAPON OBTURADOR | A11 H 2873                           |     |
| 12       | 116 7330  | 1          | VERSCHLUSSSTOPFEN | NIPPLE  | BOUCHON  | TAPON OBTURADOR | A 28,5 H 2873                        |     |

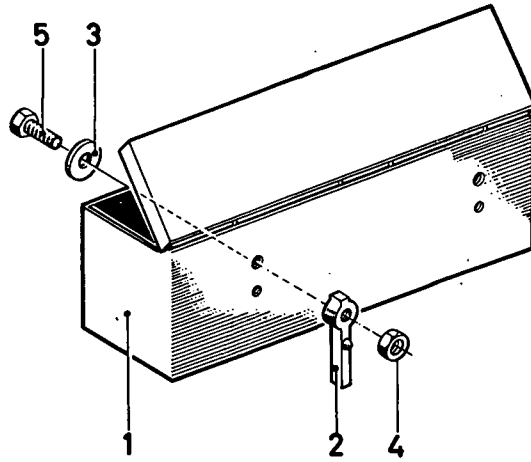

1001-60 500 3024

| Bild Nr. | Teile-Nr. | Stück-Zahl | Deutsch           | English         | Français           | Español            | Nummer/Bemerkung         | ETK |
|----------|-----------|------------|-------------------|-----------------|--------------------|--------------------|--------------------------|-----|
| 1        | 230 6803  | 1          | WERKZEUGKASTEN    | TOLLBOX         | BOITE A OUTILS     | CAJA HERRAMIENTAS  |                          |     |
| 2        | 230 6797  | 2          | ZWISCHENSTUECK    | ADAPTER         | PIECE INTERCALAIRE | PIEZA INTERMEDIA   |                          |     |
| 3        | 230 8040  | 2          | SCHEIBE           | DISC/PANE/PLATE | RONDELLE/DISQUE    | DISCO/CRISTAL/PLAT |                          |     |
| 4        | 110 2659  | 2          | SECHSKANTMUTTER   | HEX.NUT         | ECROU 6 PANS       | TUERCA HEXAGONAL   | M10 DIN 934-M 8 A4C      |     |
| 5        | 111 2423  | 2          | SECHSKANTSCHRAUBE | HEX.BOLT        | VIS 6 PANS         | TORNILLO HEXAGONAL | M10X 28 DIN 933- 8.8-A4C |     |

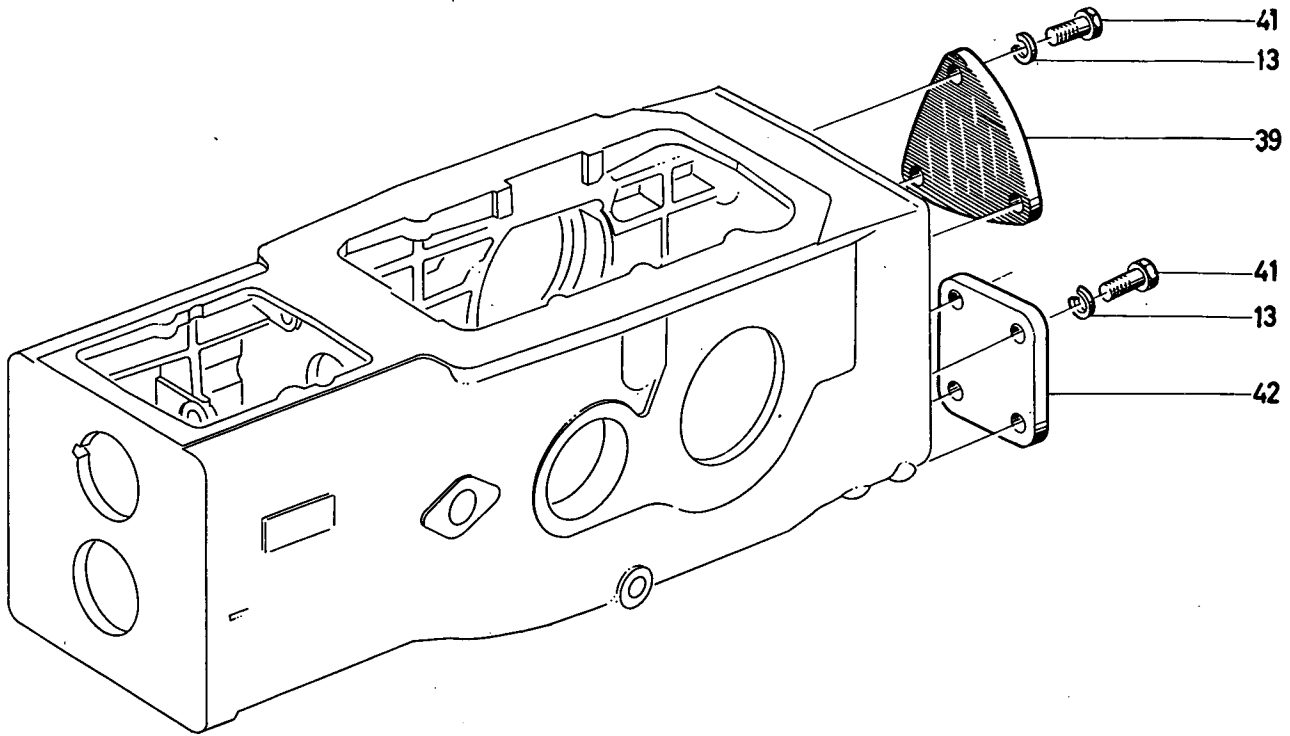

1445-77 500 4287

| Bild Nr. | Teile-Nr. | Stück-Zahl | Deutsch           | English           | Français        | Español            | Nummer/Bemerkung          | ETK |
|----------|-----------|------------|-------------------|-------------------|-----------------|--------------------|---------------------------|-----|
| 13       | 110 2799  | 3          | FEDERRING         | SPRING LOCKWASHER | RONDELLE GROVER | ARANDELA ELASTICA  | A 8 DIN 128 A4C           |     |
| 39       | 230 7582  | 1          | DECKEL            | COVER             | COUVERCLE       | TAPA               |                           |     |
| 41       | 111 2305  | 7          | SECHSKANTSCHRAUBE | HEX.BOLT          | VIS 6 PANS      | TORNILLO HEXAGONAL | M 8 X 15 DIN 933- 8.8-A4C |     |
| 42       | 232 1504  | 1          | DECKEL            | COVER             | COUVERCLE       | TAPA               |                           |     |

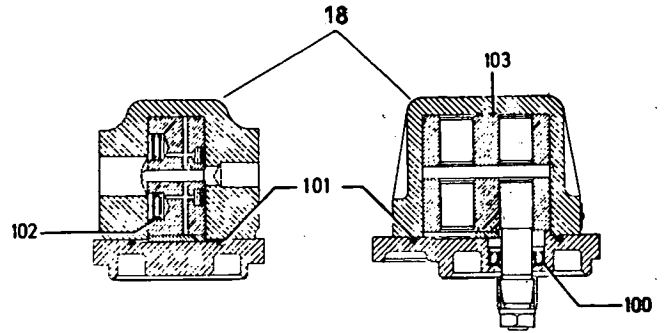
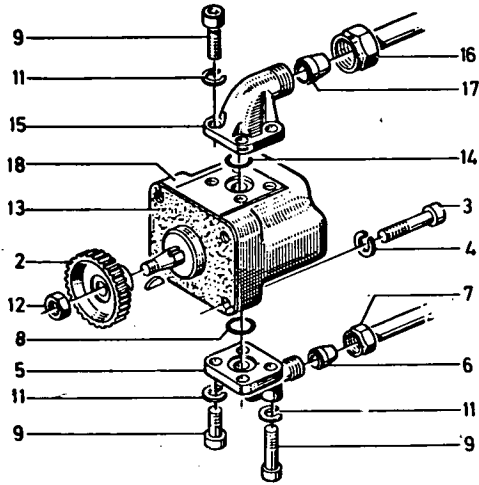

| Bld. Nr. | Teil-Nr. | Stück-Zahl | Deutsch          | English           | Français           | Español            | 1926-01 500 5251<br>Number/Bemerkung | ETK |
|----------|----------|------------|------------------|-------------------|--------------------|--------------------|--------------------------------------|-----|
| 2        | 224 0728 | 1          | ZAHNRAD          | GEAR              | ROUE DENTEE        | PUEGA DENTADA      | 1940-01-24.02 R                      |     |
| 3        | 111 0682 | 2          | ZYLINDERSCHRAUBE | CHEESE-HEAD SCREW | VIS TETE CYLINDR.  | TORN.CBZA.CILIND.  | M10X 45DIN 912- 8.8 A4C              |     |
| 4        | 111 9613 | 2          | FEDERRING        | SPRING LOCKWASHER | RONDELLE GROWER    | ARANDELA ELASTICA  | 10DIN 7980 VZKC                      |     |
| 5        | 340 0563 | 1          | FLANSCHSTUTZEN   | FLANGED SOCKET    | TUBUL A REBORD     | TUBULAD.BRIDA      | 1940-01-24.05                        |     |
| 6        | 111 6626 | 1          | SCHNEIDRING      | CUTTING RING      | BAGUE TRANCHANTE   | ANILLO CORTANTE    | L 15 DIN 3861-ST                     |     |
| 7        | 111 6653 | 1          | UEBERWURFMUTTER  | UNION NUT         | ECROU-RACCORD      | TUERCA EMPALME     | AL 15 DIN 3870-A4C                   |     |
| 8        | 116 6015 | 1          | RUNDGUMMIRING    | O-SEAL            | ANNEAU TORIQUE     | ANILLO GOMA REDOND | 18 X 2,5 H 721                       | 01  |
| 9        | 111 0517 | 8          | ZYLINDERSCHRAUBE | CHEESE-HEAD SCREW | VIS TETE CYLINDR.  | TORN.CBZA.CILIND.  | M6X22 DIN 912-10.9-A4C               |     |
| 11       | 111 9609 | 8          | FEDERRING        | SPRING LOCKWASHER | RONDELLE GROWER    | ARANDELA ELASTICA  | 6DIN 7980 VZKC                       |     |
| 12       | 112 2569 | 1          | SECHSKANTMUTTER  | HEX.NUT           | ECROU 6 PANS       | TUERCA HEXAGONAL   | M12X1,5 DIN 985-8-VZKC               |     |
| 13       | 336 4291 | 1          | DICHTUNG         | GASKET            | GARNITURE/JOINT    | JUNTA              | 0150-83-09.77                        |     |
| 14       | 116 6033 | 1          | RUNDGUMMIRING    | O-SEAL            | ANNEAU TORIQUE     | ANILLO GOMA REDOND | 25 X 2,5H 721                        | 01  |
| 15       | 340 0736 | 1          | FLANSCHSTUTZEN   | FLANGED SOCKET    | TUBUL A REBORD     | TUBULAD.BRIDA      | 1941-01-01.29                        |     |
| 16       | 111 6656 | 1          | UEBERWURFMUTTER  | UNION NUT         | ECROU-RACCORD      | TUERCA EMPALME     | AL 22DIN 3870 VZKC                   |     |
| 17       | 111 6629 | 1          | SCHNEIDRING      | CUTTING RING      | BAGUE TRANCHANTE   | ANILLO CORTANTE    | L 22 DIN 3861-ST                     |     |
| 18       | 230 8663 | 1          | HYDRAULIKPUMPE   | HYDRAULIC PUMP    | PO-MPE HYDRAULIQUE | BOMBA HIDRAULICA   | 16 CCM                               |     |
| 100      | 130 0154 | 1          | DICHTUNG         | GASKET            | GARNITURE/JOINT    | JUNTA              |                                      |     |
| 101      | 129 8473 | 1          | DICHTRING        | WASHER            | BAGUE D'ETANCHEITE | ANILLO DE JUNTA    |                                      |     |
| 102      | 129 8722 | 2          | DICHTRING        | WASHER            | BAGUE D'ETANCHEITE | ANILLO DE JUNTA    |                                      |     |
| 103      | 130 0174 | 2          | DICHTRING        | WASHER            | BAGUE D'ETANCHEITE | ANILLO DE JUNTA    |                                      |     |

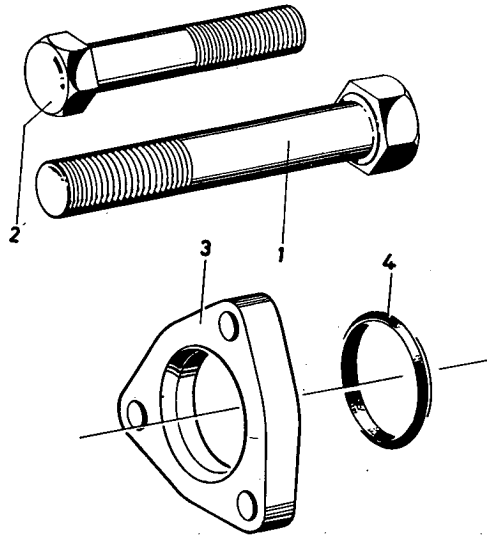

| Bild Nr. | Teile-Nr.                       | Stück-Zahl | Deutsch           | English           | Français           | Español            | 1941-21 500 5234<br>Nummer/Bemerkung | ETK |
|----------|---------------------------------|------------|-------------------|-------------------|--------------------|--------------------|--------------------------------------|-----|
| 1        | 110 1680                        | 2          | SECHSKANTSCHRAUBE | HEX.BOLT          | VIS 6 PANS         | TORNILLO HEXAGONAL | M24X2X140 DIN 960-M8.8               |     |
| 2        | 110 1679                        | 2          | SECHSKANTSCHRAUBE | HEX.BOLT          | VIS 6 PANS         | TORNILLO HEXAGONAL | M20X2X100 DIN 960-M8.8               |     |
| 3        | 336 6951                        | 1          | DREILOCHFLANSCH   | THREE-HOLE FLANGE | BRIDE A TROIS TROU | BRIDA 3 TALADROS   |                                      |     |
| 4        | <del>330 6112</del><br>334 8038 | 3          | DICHTRING         | WASHER            | BAGUE D'ETANCHEITE | ANILLO DE JUNTA    | 330 61122                            | 01  |

| TEILE-NR | SEITE | BILD | TEILE-NR | SEITE | BILD | TEILE-NR | SEITE | BILD |
|----------|-------|------|----------|-------|------|----------|-------|------|
| 110 1007 | 127   | 3    | 110 2800 | 50    | 12   | 110 7760 | 122   | 36   |
| 110 1145 | 95    | 12   | 110 2800 | 82    | 1    | 110 7770 | 97    | 6    |
| 110 1179 | 88    | 20   | 110 2800 | 115   | 46   | 110 7782 | 115   | 96   |
| 110 1323 | 123   | 151  | 110 2800 | 125   | 8    | 110 7814 | 97    | 20   |
| 110 1386 | 108   | 8    | 110 2801 | 58    | 5    | 110 7821 | 44    | 3    |
| 110 1386 | 109   | 8    | 110 2801 | 75    | 5    | 110 7834 | 67    | 5    |
| 110 1409 | 99    | 11   | 110 2863 | 89    | 14   | 110 7846 | 123   | 105  |
| 110 1490 | 38    | 1    | 110 3006 | 115   | 80   | 110 7855 | 97    | 16   |
| 110 1503 | 125   | 6    | 110 3076 | 28    | 1    | 110 7855 | 115   | 34   |
| 110 1512 | 115   | 56   | 110 3316 | 126   | 44   | 110 7859 | 114   | 25   |
| 110 1514 | 106   | 7    | 110 4151 | 123   | 132  | 110 7862 | 114   | 22   |
| 110 1596 | 114   | 12   | 110 4338 | 88    | 3    | 110 7866 | 118   | 10   |
| 110 1597 | 114   | 14   | 110 4339 | 88    | 6    | 110 8138 | 113   | 12   |
| 110 1679 | 136   | 2    | 110 4340 | 97    | 8    | 110 8981 | 121   | 28   |
| 110 1680 | 136   | 1    | 110 4687 | 126   | 34   | 110 9041 | 67    | 3    |
| 110 1909 | 121   | 20   | 110 4845 | 42    | 2    | 110 9062 | 97    | 15   |
| 110 1923 | 127   | 9    | 110 5166 | 40    | 3    | 110 9062 | 114   | 15   |
| 110 2042 | 110   | 15   | 110 5501 | 88    | 21   | 110 9118 | 97    | 1    |
| 110 2043 | 110   | 12   | 110 6354 | 122   | 68   | 110 9184 | 97    | 7    |
| 110 2046 | 46    | 2    | 110 6354 | 123   | 124  | 110 9963 | 122   | 54   |
| 110 2193 | 129   | 14   | 110 6389 | 90    | 67   | 110 9964 | 122   | 55   |
| 110 2295 | 32    | 3    | 110 6404 | 117   | 17   | 110 9965 | 114   | 11   |
| 110 2298 | 127   | 12   | 110 6408 | 106   | 8    | 110 9981 | 121   | 21   |
| 110 2301 | 56    | 1    | 110 6428 | 90    | 32   | 110 9990 | 99    | 70   |
| 110 2301 | 82    | 2    | 110 6432 | 90    | 44   | 111 0005 | 121   | 7    |
| 110 2659 | 46    | 15   | 110 6434 | 124   | 184  | 111 0190 | 65    | 2    |
| 110 2659 | 50    | 9    | 110 6447 | 117   | 20   | 111 0190 | 74    | 2    |
| 110 2659 | 56    | 4    | 110 7089 | 90    | 66   | 111 0254 | 46    | 3    |
| 110 2659 | 78    | 5    | 110 7095 | 69    | 7    | 111 0422 | 66    | 2    |
| 110 2659 | 82    | 3    | 110 7095 | 73    | 8    | 111 0517 | 135   | 9    |
| 110 2659 | 115   | 45   | 110 7095 | 88    | 16   | 111 0562 | 99    | 8    |
| 110 2659 | 122   | 72   | 110 7095 | 117   | 16   | 111 0577 | 90    | 34   |
| 110 2659 | 133   | 4    | 110 7101 | 30    | 2    | 111 0678 | 99    | 60   |
| 110 2795 | 88    | 22   | 110 7101 | 32    | 4    | 111 0682 | 135   | 3    |
| 110 2795 | 126   | 38   | 110 7101 | 48    | 3    | 111 0712 | 95    | 7    |
| 110 2797 | 56    | 7    | 110 7101 | 65    | 4    | 111 0734 | 95    | 8    |
| 110 2797 | 61    | 9    | 110 7101 | 66    | 5    | 111 0756 | 92    | 23   |
| 110 2797 | 68    | 2    | 110 7101 | 67    | 13   | 111 0805 | 92    | 22   |
| 110 2797 | 69    | 2    | 110 7101 | 69    | 12   | 111 0855 | 126   | 35   |
| 110 2797 | 69    | 8    | 110 7101 | 70    | 2    | 111 1060 | 124   | 181  |
| 110 2797 | 72    | 3    | 110 7101 | 72    | 6    | 111 1124 | 123   | 100  |
| 110 2797 | 73    | 2    | 110 7101 | 73    | 6    | 111 1132 | 48    | 1    |
| 110 2797 | 73    | 12   | 110 7101 | 78    | 13   | 111 1145 | 102   | 9    |
| 110 2797 | 80    | 5    | 110 7105 | 52    | 3    | 111 1151 | 38    | 7    |
| 110 2797 | 88    | 17   | 110 7105 | 56    | 3    | 111 1166 | 30    | 1    |
| 110 2797 | 90    | 39   | 110 7105 | 78    | 6    | 111 1168 | 51    | 2    |
| 110 2799 | 27    | 24   | 110 7279 | 103   | 113  | 111 1179 | 30    | 3    |
| 110 2799 | 29    | 6    | 110 7281 | 58    | 7    | 111 1179 | 66    | 4    |
| 110 2799 | 30    | 7    | 110 7283 | 69    | 5    | 111 1193 | 78    | 7    |
| 110 2799 | 54    | 5    | 110 7283 | 73    | 5    | 111 1195 | 30    | 6    |
| 110 2799 | 70    | 3    | 110 7283 | 88    | 23   | 111 1210 | 67    | 10   |
| 110 2799 | 72    | 7    | 110 7283 | 90    | 46   | 111 1212 | 38    | 8    |
| 110 2799 | 78    | 3    | 110 7289 | 88    | 12   | 111 1315 | 123   | 99   |
| 110 2799 | 88    | 10   | 110 7548 | 90    | 31   | 111 1325 | 123   | 98   |
| 110 2799 | 90    | 33   | 110 7549 | 113   | 17   | 111 1334 | 30    | 4    |
| 110 2799 | 102   | 8    | 110 7554 | 117   | 25   | 111 1339 | 78    | 4    |
| 110 2799 | 104   | 11   | 110 7711 | 90    | 45   | 111 1385 | 52    | 2    |
| 110 2799 | 115   | 49   | 110 7713 | 90    | 62   | 111 1475 | 75    | 3    |
| 110 2799 | 122   | 82   | 110 7749 | 99    | 29   | 111 1499 | 110   | 5    |
| 110 2799 | 129   | 17   | 110 7751 | 125   | 14   | 111 1589 | 67    | 6    |
| 110 2799 | 134   | 13   | 110 7755 | 97    | 17   | 111 1888 | 118   | 45   |
| 110 2800 | 30    | 5    | 110 7755 | 99    | 6    | 111 2179 | 126   | 37   |



| TEILE-NR | SEITE | BILD | TEILE-NR | SEITE | BILD | TEILE-NR | SEITE | BILD |
|----------|-------|------|----------|-------|------|----------|-------|------|
| 111 2232 | 72    | 2    | 111 2824 | 67    | 12   | 111 8760 | 46    | 19   |
| 111 2232 | 95    | 20   | 111 2824 | 125   | 32   | 111 8783 | 38    | 4    |
| 111 2240 | 61    | 7    | 111 2824 | 129   | 16   | 111 8970 | 31    | 7    |
| 111 2240 | 69    | 1    | 111 2841 | 96    | 16   | 111 8979 | 93    | 11   |
| 111 2240 | 69    | 6    | 111 2858 | 67    | 9    | 111 8979 | 94    | 11   |
| 111 2240 | 73    | 1    | 111 2858 | 75    | 4    | 111 8979 | 105   | 13   |
| 111 2240 | 73    | 11   | 111 2858 | 118   | 48   | 111 8979 | 112   | 3    |
| 111 2240 | 80    | 3    | 111 2861 | 58    | 6    | 111 8980 | 96    | 22   |
| 111 2248 | 54    | 6    | 111 2861 | 110   | 6    | 111 8980 | 115   | 50   |
| 111 2251 | 68    | 3    | 111 2870 | 122   | 75   | 111 8989 | 38    | 5    |
| 111 2251 | 88    | 18   | 111 2886 | 125   | 29   | 111 8998 | 115   | 83   |
| 111 2255 | 102   | 7    | 111 2908 | 127   | 4    | 111 9231 | 64    | 3    |
| 111 2264 | 97    | 22   | 111 3146 | 50    | 16   | 111 9246 | 62    | 1    |
| 111 2264 | 103   | 114  | 111 3152 | 117   | 21   | 111 9246 | 125   | 21   |
| 111 2295 | 29    | 5    | 111 3476 | 50    | 8    | 111 9246 | 128   | 3    |
| 111 2295 | 112   | 1    | 111 3477 | 123   | 167  | 111 9302 | 80    | 2    |
| 111 2295 | 123   | 163  | 111 3480 | 115   | 44   | 111 9609 | 135   | 11   |
| 111 2299 | 54    | 4    | 111 5001 | 117   | 14   | 111 9611 | 37    | 2    |
| 111 2299 | 69    | 4    | 111 5333 | 26    | 11   | 111 9613 | 135   | 4    |
| 111 2299 | 70    | 4    | 111 5407 | 117   | 18   | 111 9824 | 102   | 17   |
| 111 2299 | 73    | 4    | 111 5417 | 90    | 69   | 112 0610 | 121   | 18   |
| 111 2305 | 72    | 5    | 111 5442 | 90    | 42   | 112 0618 | 114   | 21   |
| 111 2305 | 102   | 15   | 111 5457 | 97    | 14   | 112 0677 | 118   | 12   |
| 111 2305 | 104   | 22   | 111 5458 | 114   | 31   | 112 0694 | 106   | 33   |
| 111 2305 | 134   | 41   | 111 5459 | 29    | 2    | 112 0700 | 106   | 34   |
| 111 2307 | 90    | 73   | 111 5461 | 91    | 3    | 112 1255 | 125   | 22   |
| 111 2314 | 106   | 4    | 111 5464 | 40    | 6    | 112 2350 | 26    | 6    |
| 111 2322 | 27    | 23   | 111 5471 | 90    | 41   | 112 2351 | 118   | 27   |
| 111 2322 | 113   | 9    | 111 6626 | 135   | 6    | 112 2361 | 92    | 21   |
| 111 2322 | 115   | 48   | 111 6629 | 135   | 17   | 112 2363 | 95    | 6    |
| 111 2326 | 108   | 5    | 111 6653 | 135   | 7    | 112 2389 | 90    | 53   |
| 111 2326 | 109   | 5    | 111 6656 | 135   | 16   | 112 2399 | 78    | 12   |
| 111 2326 | 125   | 31   | 111 6956 | 102   | 23   | 112 2477 | 78    | 2    |
| 111 2333 | 78    | 11   | 111 6962 | 90    | 36   | 112 2569 | 135   | 12   |
| 111 2333 | 88    | 8    | 111 7455 | 99    | 12   | 112 3546 | 118   | 29   |
| 111 2338 | 88    | 9    | 111 7861 | 54    | 7    | 112 3718 | 78    | 1    |
| 111 2339 | 38    | 2    | 111 7927 | 90    | 70   | 112 3745 | 88    | 25   |
| 111 2418 | 117   | 15   | 111 8647 | 64    | 2    | 112 3746 | 129   | 13   |
| 111 2423 | 133   | 5    | 111 8654 | 112   | 2    | 112 3749 | 90    | 38   |
| 111 2429 | 113   | 5    | 111 8654 | 113   | 10   | 112 3784 | 95    | 13   |
| 111 2439 | 125   | 9    | 111 8659 | 87    | 3    | 112 4654 | 90    | 54   |
| 111 2451 | 92    | 15   | 111 8659 | 115   | 84   | 112 4778 | 40    | 4    |
| 111 2461 | 92    | 16   | 111 8673 | 26    | 7    | 112 5780 | 114   | 13   |
| 111 2476 | 96    | 15   | 111 8673 | 66    | 3    | 112 6430 | 90    | 58   |
| 111 2494 | 88    | 13   | 111 8681 | 105   | 45   | 112 6979 | 67    | 11   |
| 111 2502 | 105   | 15   | 111 8688 | 57    | 2    | 112 8196 | 58    | 2    |
| 111 2538 | 118   | 15   | 111 8688 | 62    | 2    | 113 0548 | 129   | 8    |
| 111 2687 | 118   | 46   | 111 8688 | 128   | 4    | 116 0024 | 52    | 6    |
| 111 2693 | 118   | 47   | 111 8693 | 118   | 26   | 116 0064 | 99    | 26   |
| 111 2796 | 88    | 26   | 111 8693 | 125   | 16   | 116 0078 | 99    | 25   |
| 111 2796 | 126   | 39   | 111 8707 | 26    | 4    | 116 0079 | 99    | 37   |
| 111 2813 | 50    | 18   | 111 8707 | 125   | 26   | 116 0081 | 99    | 53   |
| 111 2813 | 54    | 8    | 111 8713 | 31    | 6    | 116 0082 | 99    | 50   |
| 111 2813 | 56    | 8    | 111 8737 | 93    | 9    | 116 0083 | 99    | 39   |
| 111 2813 | 61    | 8    | 111 8737 | 94    | 9    | 116 0097 | 26    | 20   |
| 111 2813 | 69    | 9    | 111 8737 | 96    | 23   | 116 0133 | 118   | 7    |
| 111 2813 | 73    | 7    | 111 8737 | 102   | 29   | 116 0243 | 60    | 1    |
| 111 2813 | 80    | 4    | 111 8737 | 105   | 12   | 116 0345 | 99    | 23   |
| 111 2813 | 90    | 40   | 111 8737 | 112   | 4    | 116 0592 | 68    | 4    |
| 111 2824 | 32    | 5    | 111 8737 | 113   | 2    | 116 0685 | 97    | 4    |
| 111 2824 | 46    | 13   | 111 8737 | 115   | 52   | 116 0701 | 114   | 19   |
| 111 2824 | 65    | 3    | 111 8750 | 31    | 2    | 116 0738 | 114   | 33   |

| TEILE-NR | SEITE | BILD | TEILE-NR | SEITE | BILD | TEILE-NR | SEITE | BILD |
|----------|-------|------|----------|-------|------|----------|-------|------|
| 116 1084 | 44    | 6    | 116 7331 | 132   | 3    | 121 6500 | 54    | 2    |
| 116 1089 | 44    | 7    | 116 7333 | 132   | 2    | 121 6511 | 55    | 3    |
| 116 1165 | 131   | 31   | 116 7425 | 69    | 10   | 121 6512 | 54    | 3    |
| 116 1302 | 132   | 5    | 116 7425 | 73    | 10   | 121 6884 | 49    | 3    |
| 116 1412 | 65    | 7    | 116 7496 | 97    | 5    | 121 8437 | 115   | 51   |
| 116 1469 | 61    | 5    | 116 8224 | 91    | 1    | 123 6290 | 35    | 2    |
| 116 1561 | 115   | 61   | 116 8225 | 115   | 67   | 123 6291 | 35    | 1    |
| 116 1562 | 115   | 60   | 116 8225 | 118   | 25   | 124 3184 | 62    | 3    |
| 116 1602 | 99    | 49   | 116 8225 | 125   | 2    | 126 0049 | 56    | 12   |
| 116 2103 | 44    | 954  | 116 8226 | 123   | 86   | 126 6159 | 62    | 4    |
| 116 2104 | 44    | 953  | 116 8226 | 123   | 155  | 129 8473 | 135   | 101  |
| 116 2303 | 44    | 5    | 116 8227 | 95    | 14   | 129 8722 | 135   | 102  |
| 116 2469 | 44    | 952  | 116 8713 | 100   | 112  | 130 0154 | 135   | 100  |
| 116 2511 | 102   | 20   | 116 8741 | 99    | 24   | 130 0174 | 135   | 103  |
| 116 2625 | 56    | 11   | 116 8764 | 100   | 111  | 210 1006 | 28    | 2    |
| 116 2930 | 99    | 40   | 116 8817 | 46    | 5    | 210 1007 | 28    | 3    |
| 116 3008 | 81    | 1    | 116 9304 | 131   | 20   | 210 1175 | 39    | 950  |
| 116 3642 | 103   | 78   | 116 9360 | 84    | 2    | 210 1221 | 59    | 4    |
| 116 3773 | 86    | 1    | 116 9588 | 114   | 23   | 210 1222 | 49    | 1    |
| 116 3942 | 34    | 4    | 116 9634 | 26    | 16   | 210 1238 | 52    | 4    |
| 116 3984 | 77    | 1    | 116 9689 | 51    | 3    | 210 1292 | 34    | 1    |
| 116 3985 | 76    | 1    | 116 9689 | 99    | 9    | 210 1390 | 38    | 6    |
| 116 4003 | 100   | 102  | 116 9689 | 108   | 6    | 210 1681 | 46    | 21   |
| 116 4045 | 97    | 12   | 116 9689 | 109   | 6    | 210 1698 | 73    | 9    |
| 116 4046 | 97    | 21   | 116 9694 | 92    | 3    | 210 1700 | 70    | 5    |
| 116 4994 | 82    | 4    | 116 9694 | 99    | 59   | 210 1702 | 71    | 1    |
| 116 5397 | 129   | 7    | 116 9695 | 92    | 8    | 210 1802 | 70    | 1    |
| 116 5788 | 66    | 1    | 116 9695 | 105   | 14   | 210 1805 | 69    | 11   |
| 116 5789 | 65    | 5    | 116 9696 | 92    | 6    | 210 1937 | 34    | 2    |
| 116 5830 | 112   | 5    | 117 0440 | 84    | 1    | 210 2046 | 34    | 3    |
| 116 5830 | 114   | 32   | 117 0580 | 40    | 7    | 210 2217 | 72    | 1    |
| 116 5839 | 87    | 1    | 117 0642 | 61    | 6    | 210 2340 | 74    | 4    |
| 116 5839 | 114   | 24   | 117 0652 | 79    | 1    | 210 2660 | 56    | 10   |
| 116 5975 | 36    | 2    | 117 2105 | 90    | 59   | 213 0225 | 56    | 13   |
| 116 6002 | 53    | 2    | 117 2311 | 45    | 958  | 213 0375 | 51    | 4    |
| 116 6015 | 135   | 8    | 117 2312 | 45    | 957  | 213 0440 | 51    | 1    |
| 116 6033 | 135   | 14   | 117 2313 | 45    | 959  | 213 0507 | 37    | 1    |
| 116 6110 | 29    | 4    | 121 1206 | 58    | 1    | 213 1081 | 42    | 3    |
| 116 6110 | 32    | 2    | 121 1206 | 78    | 10   | 213 3633 | 67    | 4    |
| 116 6121 | 99    | 71   | 121 1590 | 129   | 11   | 213 3636 | 67    | 8    |
| 116 6126 | 99    | 61   | 121 1692 | 115   | 72   | 213 3781 | 29    | 3    |
| 116 6346 | 102   | 21   | 121 1693 | 115   | 73   | 213 3809 | 44    | 4    |
| 116 6417 | 129   | 12   | 121 2263 | 131   | 32   | 213 3871 | 43    | 5    |
| 116 6836 | 115   | 62   | 121 4988 | 26    | 3    | 213 3985 | 50    | 2    |
| 116 6951 | 41    | 2    | 121 5235 | 26    | 5    | 213 4336 | 41    | 1    |
| 116 7010 | 40    | 8    | 121 5500 | 46    | 9    | 213 4511 | 56    | 9    |
| 116 7153 | 129   | 19   | 121 5567 | 87    | 2    | 213 5002 | 57    | 1    |
| 116 7169 | 118   | 13   | 121 5748 | 78    | 8    | 213 5335 | 52    | 5    |
| 116 7193 | 129   | 15   | 121 5749 | 78    | 9    | 213 5532 | 65    | 6    |
| 116 7194 | 97    | 23   | 121 5850 | 69    | 3    | 213 5902 | 67    | 7    |
| 116 7266 | 26    | 9    | 121 5850 | 72    | 4    | 213 5910 | 48    | 5    |
| 116 7308 | 132   | 6    | 121 5850 | 73    | 3    | 213 6027 | 29    | 1    |
| 116 7311 | 132   | 8    | 121 5909 | 110   | 7    | 213 6101 | 43    | 2    |
| 116 7313 | 132   | 11   | 121 6035 | 107   | 62   | 213 6359 | 53    | 1    |
| 116 7315 | 132   | 7    | 121 6057 | 99    | 66   | 213 6526 | 43    | 1    |
| 116 7316 | 132   | 1    | 121 6080 | 50    | 7    | 213 6596 | 46    | 18   |
| 116 7319 | 132   | 10   | 121 6107 | 26    | 17   | 213 6596 | 46    | 20   |
| 116 7325 | 93    | 20   | 121 6119 | 40    | 5    | 213 6717 | 56    | 2    |
| 116 7325 | 94    | 20   | 121 6128 | 41    | 3    | 213 6928 | 40    | 1    |
| 116 7326 | 132   | 9    | 121 6240 | 26    | 8    | 213 6952 | 44    | 1    |
| 116 7328 | 132   | 4    | 121 6307 | 48    | 2    | 213 6958 | 44    | 950  |
| 116 7330 | 132   | 12   | 121 6492 | 64    | 4    | 213 7096 | 46    | 17   |

| TEILE-NR | SEITE | BILD | TEILE-NR | SEITE | BILD | TEILE-NR | SEITE | BILD |
|----------|-------|------|----------|-------|------|----------|-------|------|
| 213 7256 | 39    | 2    | 223 0852 | 50    | 14   | 230 6244 | 114   | 30   |
| 213 7300 | 46    | 7    | 223 1082 | 26    | 10   | 230 6245 | 117   | 11   |
| 213 7301 | 46    | 8    | 223 1154 | 46    | 1    | 230 6246 | 117   | 9    |
| 213 7302 | 46    | 12   | 223 1469 | 44    | 955  | 230 6247 | 117   | 10   |
| 213 7303 | 47    | 955  | 223 1470 | 44    | 956  | 230 6256 | 117   | 12   |
| 213 7304 | 47    | 956  | 224 0728 | 135   | 2    | 230 6257 | 117   | 6    |
| 213 7305 | 47    | 957  | 230 0737 | 110   | 4    | 230 6258 | 117   | 5    |
| 213 7306 | 46    | 11   | 230 1172 | 100   | 126  | 230 6297 | 114   | 16   |
| 213 7307 | 46    | 952  | 230 1501 | 102   | 10   | 230 6730 | 114   | 26   |
| 213 7308 | 47    | 953  | 230 1515 | 127   | 2    | 230 6731 | 116   | 967  |
| 213 7309 | 47    | 954  | 230 1561 | 117   | 13   | 230 6732 | 116   | 968  |
| 213 7358 | 68    | 1    | 230 1891 | 99    | 33   | 230 6733 | 116   | 969  |
| 213 7519 | 63    | 1    | 230 1895 | 99    | 15   | 230 6734 | 116   | 970  |
| 213 7568 | 59    | 2    | 230 1896 | 99    | 13   | 230 6735 | 116   | 971  |
| 213 7580 | 46    | 16   | 230 1897 | 99    | 28   | 230 6739 | 114   | 17   |
| 213 7591 | 46    | 14   | 230 2045 | 99    | 27   | 230 6740 | 115   | 950  |
| 213 7750 | 43    | 4    | 230 2046 | 100   | 958  | 230 6741 | 115   | 951  |
| 213 7754 | 43    | 950  | 230 2047 | 100   | 959  | 230 6742 | 115   | 952  |
| 213 7758 | 43    | 951  | 230 2048 | 100   | 960  | 230 6743 | 115   | 953  |
| 213 7762 | 43    | 952  | 230 2049 | 100   | 961  | 230 6744 | 115   | 954  |
| 213 7766 | 43    | 953  | 230 2050 | 100   | 962  | 230 6745 | 115   | 955  |
| 213 7770 | 43    | 954  | 230 2051 | 100   | 963  | 230 6746 | 115   | 956  |
| 213 7774 | 43    | 955  | 230 2052 | 100   | 964  | 230 6746 | 115   | 957  |
| 213 7828 | 39    | 1    | 230 2053 | 100   | 965  | 230 6748 | 115   | 958  |
| 213 7842 | 26    | 21   | 230 2054 | 100   | 966  | 230 6749 | 115   | 959  |
| 213 7912 | 59    | 3    | 230 2055 | 99    | 7    | 230 6750 | 115   | 960  |
| 213 7916 | 61    | 1    | 230 2056 | 100   | 950  | 230 6751 | 116   | 961  |
| 213 7917 | 61    | 2    | 230 2057 | 100   | 951  | 230 6752 | 116   | 962  |
| 213 7918 | 61    | 3    | 230 2058 | 100   | 952  | 230 6753 | 116   | 963  |
| 213 7996 | 64    | 1    | 230 2059 | 100   | 953  | 230 6754 | 116   | 964  |
| 213 8152 | 56    | 6    | 230 2060 | 100   | 954  | 230 6755 | 116   | 965  |
| 213 8184 | 26    | 18   | 230 2061 | 100   | 955  | 230 6756 | 116   | 966  |
| 213 8185 | 26    | 19   | 230 2062 | 100   | 956  | 230 6797 | 133   | 2    |
| 213 9284 | 58    | 3    | 230 2063 | 100   | 957  | 230 6803 | 133   | 1    |
| 213 9287 | 58    | 4    | 230 2212 | 102   | 35   | 230 6850 | 106   | 29   |
| 213 9600 | 50    | 19   | 230 2213 | 102   | 36   | 230 6852 | 106   | 31   |
| 213 9737 | 26    | 14   | 230 2258 | 118   | 9    | 230 6853 | 106   | 32   |
| 213 9851 | 67    | 14   | 230 2259 | 118   | 11   | 230 6856 | 106   | 35   |
| 213 9852 | 67    | 1    | 230 2351 | 99    | 20   | 230 6861 | 106   | 6    |
| 216 5716 | 54    | 1    | 230 2353 | 99    | 17   | 230 7445 | 115   | 59   |
| 216 6129 | 78    | 14   | 230 2386 | 99    | 14   | 230 7571 | 99    | 69   |
| 216 6516 | 78    | 15   | 230 3440 | 99    | 45   | 230 7582 | 134   | 39   |
| 216 6522 | 80    | 1    | 230 3561 | 99    | 75   | 230 7600 | 102   | 48   |
| 216 8371 | 42    | 1    | 230 3565 | 102   | 41   | 230 7702 | 104   | 23   |
| 216 9842 | 77    | 2    | 230 3566 | 99    | 18   | 230 7795 | 99    | 74   |
| 217 9493 | 83    | 1    | 230 3570 | 99    | 16   | 230 7796 | 99    | 76   |
| 223 0134 | 40    | 9    | 230 3581 | 102   | 44   | 230 8040 | 133   | 3    |
| 223 0170 | 26    | 13   | 230 3582 | 102   | 43   | 230 8112 | 95    | 3    |
| 223 0172 | 27    | 960  | 230 3612 | 96    | 24   | 230 8663 | 135   | 18   |
| 223 0173 | 27    | 961  | 230 3612 | 115   | 54   | 230 9252 | 100   | 967  |
| 223 0174 | 27    | 962  | 230 5008 | 126   | 49   | 230 9386 | 127   | 8    |
| 223 0175 | 27    | 963  | 230 5009 | 126   | 50   | 230 9517 | 118   | 8    |
| 223 0181 | 26    | 12   | 230 5010 | 126   | 52   | 230 9759 | 106   | 2    |
| 223 0182 | 27    | 956  | 230 5011 | 126   | 51   | 230 9766 | 106   | 36   |
| 223 0183 | 27    | 957  | 230 6225 | 114   | 8    | 231 0951 | 115   | 63   |
| 223 0184 | 27    | 958  | 230 6227 | 114   | 28   | 231 1118 | 121   | 24   |
| 223 0185 | 27    | 959  | 230 6233 | 115   | 47   | 231 1120 | 123   | 160  |
| 223 0292 | 44    | 951  | 230 6235 | 114   | 20   | 231 1121 | 123   | 135  |
| 223 0526 | 26    | 1    | 230 6238 | 114   | 27   | 231 1124 | 121   | 4    |
| 223 0849 | 50    | 13   | 230 6240 | 115   | 94   | 231 1127 | 122   | 43   |
| 223 0850 | 50    | 17   | 230 6241 | 115   | 95   | 231 1128 | 122   | 44   |
| 223 0851 | 50    | 20   | 230 6242 | 114   | 29   | 231 1129 | 122   | 76   |

| TEILE-NR | SEITE | BILD | TEILE-NR | SEITE | BILD | TEILE-NR | SEITE | BILD |
|----------|-------|------|----------|-------|------|----------|-------|------|
| 231 1131 | 122   | 52   | 231 4341 | 109   | 2    | 232 9752 | 91    | 4    |
| 231 1134 | 122   | 77   | 231 5409 | 115   | 66   | 232 9756 | 88    | 27   |
| 231 1139 | 122   | 32   | 231 5423 | 117   | 22   | 232 9758 | 88    | 1    |
| 231 1140 | 122   | 31   | 231 5424 | 117   | 23   | 232 9760 | 88    | 2    |
| 231 1141 | 121   | 12   | 231 5425 | 117   | 24   | 232 9761 | 88    | 4    |
| 231 1144 | 122   | 39   | 231 5688 | 123   | 156  | 232 9763 | 88    | 5    |
| 231 1147 | 122   | 34   | 231 5915 | 118   | 4    | 233 0369 | 123   | 152  |
| 231 1148 | 121   | 11   | 231 5917 | 118   | 3    | 233 0371 | 123   | 145  |
| 231 1149 | 121   | 27   | 231 5962 | 118   | 5    | 233 0372 | 124   | 172  |
| 231 1151 | 121   | 9    | 231 5967 | 129   | 9    | 233 2270 | 126   | 45   |
| 231 1153 | 122   | 66   | 231 5968 | 129   | 10   | 233 2674 | 125   | 10   |
| 231 1154 | 121   | 8    | 231 5980 | 115   | 70   | 233 2675 | 125   | 13   |
| 231 1155 | 122   | 35   | 231 5981 | 115   | 71   | 233 2678 | 125   | 19   |
| 231 1156 | 122   | 46   | 231 5982 | 121   | 3    | 233 2679 | 125   | 20   |
| 231 1157 | 122   | 37   | 231 5984 | 121   | 2    | 233 2680 | 125   | 15   |
| 231 1159 | 122   | 61   | 231 6043 | 123   | 102  | 233 2771 | 126   | 46   |
| 231 1160 | 122   | 30   | 231 6100 | 108   | 3    | 233 3416 | 103   | 89   |
| 231 1161 | 122   | 64   | 231 6100 | 109   | 3    | 233 3422 | 99    | 63   |
| 231 1162 | 122   | 63   | 231 6155 | 99    | 62   | 233 3422 | 100   | 103  |
| 231 1163 | 122   | 41   | 231 6231 | 115   | 69   | 233 3423 | 100   | 132  |
| 231 1164 | 121   | 22   | 231 6787 | 123   | 153  | 233 3430 | 97    | 2    |
| 231 1165 | 123   | 165  | 231 6795 | 100   | 121  | 233 3817 | 126   | 53   |
| 231 1166 | 121   | 19   | 231 6797 | 103   | 72   | 233 3818 | 126   | 54   |
| 231 1167 | 122   | 58   | 231 6972 | 103   | 77   | 233 3941 | 97    | 9    |
| 231 1168 | 122   | 57   | 231 7066 | 110   | 3    | 233 3943 | 97    | 10   |
| 231 1170 | 122   | 70   | 231 7068 | 110   | 11   | 233 3944 | 97    | 18   |
| 231 1171 | 121   | 25   | 231 9524 | 115   | 77   | 233 3945 | 97    | 19   |
| 231 1172 | 123   | 162  | 232 1504 | 134   | 42   | 233 3946 | 97    | 25   |
| 231 1173 | 121   | 26   | 232 1981 | 123   | 108  | 233 3951 | 96    | 21   |
| 231 1174 | 122   | 79   | 232 2599 | 124   | 951  | 233 4004 | 100   | 127  |
| 231 1177 | 122   | 80   | 232 2600 | 124   | 950  | 233 4037 | 127   | 1    |
| 231 1178 | 122   | 65   | 232 2665 | 125   | 7    | 233 4684 | 99    | 4    |
| 231 1179 | 122   | 74   | 232 2921 | 129   | 6    | 233 5260 | 99    | 44   |
| 231 1180 | 121   | 14   | 232 5021 | 113   | 18   | 233 5932 | 100   | 107  |
| 231 1182 | 123   | 166  | 232 5104 | 108   | 1    | 233 5935 | 110   | 24   |
| 231 1182 | 124   | 170  | 232 5105 | 108   | 10   | 233 5937 | 110   | 950  |
| 231 1183 | 122   | 78   | 232 5105 | 109   | 10   | 233 5938 | 110   | 952  |
| 231 1184 | 122   | 42   | 232 5136 | 109   | 11   | 233 5939 | 110   | 954  |
| 231 1186 | 124   | 180  | 232 5551 | 123   | 110  | 233 5940 | 111   | 956  |
| 231 1187 | 124   | 182  | 232 5661 | 115   | 79   | 233 5941 | 111   | 958  |
| 231 1188 | 124   | 183  | 232 5737 | 123   | 161  | 233 5942 | 111   | 960  |
| 231 1190 | 122   | 40   | 232 5790 | 123   | 111  | 233 5943 | 111   | 962  |
| 231 1193 | 122   | 62   | 232 5791 | 123   | 113  | 233 5944 | 111   | 964  |
| 231 1194 | 122   | 29   | 232 5792 | 123   | 114  | 233 5946 | 111   | 966  |
| 231 1195 | 121   | 23   | 232 5793 | 123   | 115  | 233 5951 | 100   | 106  |
| 231 1196 | 121   | 10   | 232 5794 | 123   | 116  | 233 5970 | 110   | 951  |
| 231 1197 | 122   | 47   | 232 5795 | 123   | 117  | 233 5971 | 110   | 953  |
| 231 1198 | 122   | 48   | 232 5796 | 123   | 118  | 233 5972 | 110   | 955  |
| 231 1201 | 123   | 88   | 232 5797 | 105   | 51   | 233 5973 | 111   | 957  |
| 231 1202 | 123   | 164  | 232 5798 | 105   | 52   | 233 5974 | 111   | 959  |
| 231 1203 | 122   | 56   | 232 6077 | 118   | 6    | 233 5975 | 111   | 961  |
| 231 1284 | 102   | 49   | 232 6087 | 125   | 4    | 233 5976 | 111   | 963  |
| 231 1411 | 128   | 8    | 232 6088 | 125   | 5    | 233 5977 | 111   | 965  |
| 231 1696 | 128   | 5    | 232 6089 | 125   | 11   | 233 6405 | 100   | 114  |
| 231 1811 | 110   | 14   | 232 9511 | 125   | 1    | 233 9257 | 123   | 119  |
| 231 2293 | 121   | 16   | 232 9589 | 103   | 110  | 233 9345 | 123   | 154  |
| 231 3564 | 102   | 67   | 232 9617 | 92    | 26   | 233 9812 | 129   | 2    |
| 231 3566 | 108   | 9    | 232 9624 | 107   | 72   | 233 9813 | 129   | 3    |
| 231 3566 | 109   | 9    | 232 9739 | 97    | 3    | 233 9818 | 126   | 33   |
| 231 3568 | 102   | 69   | 232 9741 | 97    | 11   | 233 9837 | 125   | 30   |
| 231 3631 | 102   | 71   | 232 9743 | 97    | 24   | 237 0830 | 126   | 36   |
| 231 4341 | 108   | 2    | 232 9745 | 97    | 13   | 237 0886 | 110   | 1    |

| TEILE-NR | SEITE | BILD | TEILE-NR | SEITE | BILD | TEILE-NR | SEITE | BILD |
|----------|-------|------|----------|-------|------|----------|-------|------|
| 237 1395 | 117   | 31   | 238 1693 | 90    | 63   | 336 2538 | 28    | 4    |
| 237 1399 | 117   | 30   | 238 1694 | 90    | 64   | 336 2541 | 28    | 5    |
| 237 2170 | 118   | 40   | 238 1695 | 90    | 65   | 336 2573 | 38    | 3    |
| 237 2174 | 123   | 121  | 238 1696 | 90    | 68   | 336 2737 | 40    | 2    |
| 237 2175 | 123   | 122  | 238 1697 | 89    | 22   | 336 2983 | 52    | 1    |
| 237 2778 | 129   | 4    | 238 1698 | 90    | 49   | 336 3064 | 54    | 9    |
| 237 3214 | 110   | 27   | 238 1699 | 89    | 25   | 336 3069 | 55    | 2    |
| 237 3524 | 123   | 123  | 238 1948 | 91    | 10   | 336 3070 | 55    | 1    |
| 237 3746 | 126   | 48   | 238 2022 | 124   | 193  | 336 3161 | 56    | 5    |
| 237 4896 | 129   | 5    | 238 2025 | 124   | 195  | 336 3658 | 67    | 2    |
| 237 4936 | 129   | 1    | 238 2442 | 90    | 27   | 336 4291 | 135   | 13   |
| 237 4971 | 99    | 46   | 238 2446 | 89    | 21   | 336 5861 | 50    | 15   |
| 237 5053 | 129   | 20   | 238 2447 | 89    | 24   | 336 6951 | 75    | 1    |
| 237 5154 | 130   | 1    | 238 2448 | 89    | 23   | 336 6951 | 136   | 3    |
| 237 5938 | 119   | 54   | 238 2449 | 89    | 26   | 336 7789 | 49    | 2    |
| 237 6467 | 90    | 51   | 238 2550 | 90    | 28   | 336 9305 | 46    | 6    |
| 237 6468 | 90    | 56   | 238 2551 | 90    | 29   | 337 1612 | 43    | 3    |
| 237 6469 | 90    | 57   | 238 2552 | 89    | 17   | 337 1660 | 44    | 2    |
| 237 6770 | 124   | 176  | 238 2553 | 89    | 6    | 337 1666 | 46    | 22   |
| 237 8881 | 118   | 49   | 238 2554 | 89    | 7    | 337 1689 | 65    | 1    |
| 237 8908 | 118   | 44   | 238 2555 | 89    | 3    | 337 1689 | 74    | 1    |
| 237 8910 | 93    | 28   | 238 2556 | 89    | 12   | 337 1692 | 48    | 4    |
| 237 8913 | 94    | 29   | 238 2557 | 90    | 55   | 337 1748 | 46    | 4    |
| 237 8919 | 118   | 53   | 238 2558 | 90    | 30   | 337 1761 | 46    | 10   |
| 237 8923 | 119   | 55   | 238 2559 | 90    | 35   | 337 1866 | 50    | 10   |
| 237 8924 | 119   | 58   | 238 2560 | 90    | 72   | 337 1867 | 50    | 11   |
| 237 8933 | 123   | 157  | 238 2561 | 89    | 15   | 337 1876 | 50    | 5    |
| 237 8935 | 123   | 158  | 238 2562 | 90    | 37   | 337 1881 | 50    | 3    |
| 237 8936 | 123   | 159  | 238 2563 | 89    | 19   | 337 1885 | 50    | 1    |
| 237 8938 | 124   | 174  | 238 2564 | 89    | 2    | 337 1887 | 50    | 4    |
| 237 8939 | 121   | 13   | 238 2565 | 89    | 13   | 337 1888 | 50    | 6    |
| 237 8943 | 124   | 171  | 238 2566 | 89    | 18   | 337 2164 | 59    | 1    |
| 237 8948 | 124   | 173  | 238 2567 | 90    | 52   | 337 2269 | 61    | 4    |
| 237 9161 | 129   | 18   | 238 2568 | 90    | 71   | 338 6770 | 97    | 26   |
| 237 9265 | 88    | 11   | 238 2680 | 93    | 32   | 338 6770 | 102   | 22   |
| 237 9267 | 88    | 24   | 238 4210 | 115   | 82   | 338 7604 | 113   | 4    |
| 237 9268 | 88    | 19   | 238 4799 | 126   | 55   | 338 8595 | 128   | 2    |
| 237 9270 | 88    | 15   | 238 5124 | 90    | 75   | 338 8928 | 117   | 4    |
| 237 9271 | 88    | 14   | 238 5125 | 90    | 76   | 338 8929 | 117   | 3    |
| 237 9610 | 89    | 1    | 238 6548 | 106   | 21   | 338 9261 | 88    | 7    |
| 237 9611 | 90    | 43   | 240 5960 | 85    | 1    | 338 9276 | 96    | 4    |
| 237 9612 | 89    | 8    | 330 6112 | 136   | 4    | 339 1875 | 100   | 968  |
| 237 9613 | 89    | 16   | 331 6466 | 74    | 3    | 339 1876 | 100   | 969  |
| 237 9614 | 89    | 9    | 334 8038 | 75    | 2    | 339 1877 | 100   | 970  |
| 237 9615 | 89    | 4    | 336 1809 | 68    | 5    | 339 1878 | 100   | 971  |
| 237 9617 | 89    | 5    | 336 2279 | 26    | 15   | 339 1879 | 100   | 972  |
| 237 9618 | 89    | 10   | 336 2293 | 31    | 3    | 339 1880 | 99    | 58   |
| 237 9619 | 89    | 11   | 336 2294 | 31    | 4    | 339 1929 | 103   | 105  |
| 238 1081 | 100   | 113  | 336 2295 | 31    | 5    | 339 1943 | 102   | 11   |
| 238 1082 | 101   | 973  | 336 2337 | 27    | 22   | 339 1944 | 102   | 19   |
| 238 1083 | 101   | 974  | 336 2379 | 26    | 2    | 339 2442 | 99    | 65   |
| 238 1084 | 101   | 975  | 336 2380 | 27    | 950  | 339 2443 | 99    | 68   |
| 238 1085 | 101   | 976  | 336 2381 | 27    | 951  | 339 2503 | 108   | 950  |
| 238 1086 | 101   | 977  | 336 2382 | 27    | 952  | 339 2503 | 109   | 950  |
| 238 1087 | 101   | 978  | 336 2383 | 27    | 953  | 339 2504 | 108   | 951  |
| 238 1088 | 101   | 980  | 336 2384 | 27    | 954  | 339 2504 | 109   | 951  |
| 238 1091 | 100   | 124  | 336 2385 | 27    | 955  | 339 2505 | 108   | 952  |
| 238 1272 | 110   | 2    | 336 2498 | 36    | 1    | 339 2505 | 109   | 952  |
| 238 1587 | 124   | 177  | 336 2504 | 32    | 1    | 339 2508 | 108   | 953  |
| 238 1687 | 89    | 20   | 336 2504 | 33    | 1    | 339 2508 | 109   | 953  |
| 238 1689 | 90    | 60   | 336 2505 | 29    | 7    | 339 2511 | 108   | 954  |
| 238 1692 | 90    | 61   | 336 2510 | 31    | 1    | 339 2511 | 109   | 954  |

| TEILE-NR | SEITE | BILD |
|----------|-------|------|
| 339 2513 | 108   | 955  |
| 339 2513 | 109   | 955  |
| 339 2522 | 108   | 7    |
| 339 2522 | 108   | 956  |
| 339 2522 | 109   | 956  |
| 339 2531 | 110   | 9    |
| 339 2533 | 110   | 10   |
| 339 2540 | 113   | 1    |
| 339 3040 | 108   | 4    |
| 339 3040 | 109   | 4    |
| 339 3268 | 118   | 28   |
| 340 0563 | 135   | 5    |
| 340 0736 | 135   | 15   |
| 346 9596 | 53    | 3    |
| 347 1122 | 113   | 3    |

| TEILE-NR | SEITE | BILD |
|----------|-------|------|
|----------|-------|------|

| TEILE-NR | SEITE | BILD |
|----------|-------|------|
|----------|-------|------|

R e m a r k s  
=====

B 001 = From axle No.  
B 002 = From axle No. .... item  
B 003 = From chassis No.  
B 004 = From chassis No. .... item  
B 005 = From gearbox No.  
B 006 = From gearbox No. .... item  
B 007 = From engine ser.No.  
B 008 = From engine ser.No. .... see chart  
B 009 = Four-wheel drive  
B 010 = Amperes  
B 011 = Design  
B 012 = Exhaust upwards  
B 013 = External  
B 014 = Outer dia.  
B 015 = Old item No.  
B 025 = Up to axle No.  
B 026 = Up to axle No. .... item  
B 027 = Up to chassis No.  
B 028 = Up to chassis No. .... item  
B 029 = Up to gearbox No.  
B 030 = Up to gearbox No. .... item  
B 031 = Up to engine ser.No.  
B 032 = Up to engine ser.No. .... see chart  
B 033 = For design with blinker light  
B 034 = For design with two-speed PTO shaft  
B 035 = For design with short guide rail  
B 036 = For design with stand. dual clutch  
B 037 = For design with IPTO dual clutch  
B 038 = For design with tank level indicator  
B 039 = For design with ground speed PTO shaft  
B 040 = With retractable steering wheel, w/o three-point linkage, w/o pivoted drawbar  
B 041 = For initial replacement item ... to be supplied  
B 042 = For initial replacement supply item ... up to chassis No. ....  
B 043 = For hydr. steering  
B 044 = For hydrostatic steering

- B 045 = With headlamps, top
- B 046 = With headlamps, outer
- B 047 = For version with item .....
- B 048 = For version without item .....
- B 049 = On Type ....., only for version with differential
- B 050 = Consisting of item .....
- B 060 = Canada design
- B 061 = Illustration
- B 062 = German
- B 063 = Diameter
- B 064 = Double
- B 070 = Single
- B 071 = English
- B 072 = Spare part No.
- B 073 = Use up stock first
- B 074 = Replacement for item .....
- B 075 = Replaced by item .....
- B 076 = For single parts see item .....
- B 080 = French
- B 081 = For air intake from above
- B 082 = For standard exhaust system and head lights
- B 083 = For exhaust upwards and standard head lights
- B 084 = For design with 1 KHD interm. control unit and 1 Westinghouse flange-type unit
- B 085 = For design w. 2 interm. units and 1 KHD terminal unit
- B 086 = For design w. 1 KHD interm. unit, 1 adapter plate, 1 Westinghouse interm. unit and 1 Westinghouse flange-type unit
- B 087 = For design w. 2 KHD interm. units 1 adapter plate and 1 Westinghouse flange-type unit
- B 088 = For design w. 2 KHD interm. units and 1 term.plate or 1 KHD interm. unit and 1 term.plate
- B 089 = For design w. 1 KHD terminal unit or 1 KHD interm. unit and 1 term. plate
- B 090 = For design w. 1 adapter plate and 1 Westinghouse flange-type unit
- B 091 = For design w. 1 adapter plate, 1 Westinghouse interm. unit and 1 Westinghouse flange-type unit
- B 092 = For design with hydr. lift
- B 093 = For design w/o hydr. lift
- B 094 = For tyres



B 095 = For twin filament bulb  
B 096 = For brake pedal  
B 097 = For twin filter  
B 098 = For dual clutch  
B 099 = For alternator  
B 100 = For three-point linkage  
B 101 = For differeential lock  
B 102 = For single filter  
B 103 = For gas pedal  
B 104 = For housing cover  
B 105 = For dynamo  
B 106 = Hydr. steering  
B 107 = For cabin  
B 108 = For clutch  
B 109 = For creep gear design  
B 110 = For engine hood w/o head fights  
B 111 = For windscreen wiper  
B 112 = For head light  
B 113 = For synchronized transmission  
B 114 = For PTO shaft  
B 115 = For pivoted drawbar  
B 116 = For charging control  
B 117 = For oil pressure control  
B 118 = For filter control  
B 119 = For main beam control  
B 120 = Temperature indicator  
B 121 = For air blower  
B 122 = For trailer blinker  
B 123 = For tractor blinker  
B 124 = For head lamp, outer  
B 125 = For longhole  
B 126 = For version with 1 KHD intermediate controlunit and 1 adapter plate  
B 127 = Chassis No. like item .....  
B 128 = For final drive  
B 129 = For telescopic axle  
B 130 = For standard axle

B 131 = For standard exhaust and head lamps, intake at front  
B 132 = For exhaust and intake stack, standard head lamp  
B 133 = For ordinary TPO-shaft  
B 134 = For ground-speed PTO-shaft  
B 135 = For trailer socket  
B 136 = For work lamp  
B 137 = For number plate  
B 138 = For mechanical and hydro-steering system  
B 139 = For Dry-type Air Cleaner  
B 140 = For Oil Bath Air Cleaner  
B 141 = Gear  
B 142 = On transmission end  
B 143 = Large  
B 144 = Assembly  
B 145 = Yellow  
B 150 = Rear  
B 151 = Rear, LH  
B 152 = Rear, RH  
B 153 = Dutch  
B 154 = Hydro-actuation  
B 161 = Inside  
B 162 = Inner dia.  
B 163 = Italian  
B 171 = Category  
B 172 = Kilogram  
B 173 = Mudguard, rear  
B 174 = Mudguard, rear LH  
B 175 = Mudguard, rear RH  
B 176 = Mudguard, front  
B 177 = Mudguard, front LH  
B 178 = Mudguard, front RH  
B 179 = Creep gear  
B 180 = Cubic centimeter  
B 181 = Cubic decimeter  
B 182 = short  
B 190 = Long  
B 191 = Slow  
B 192 = Light  
B 193 = Specification  
B 194 = Left half  
B 195 = LH

- B 196 = LH thread
- B 197 = LH cpl.
- B 198 = Left and right
- B 199 = Litre
- B 204 = Available by the meter
- B 205 = With adapter plate
- B 206 = With flange-type unit
- B 207 = With trailer socket
- B 208 = With starting lock
- B 209 = With external head light
- B 210 = With crank
- B 211 = With item .....
- B 212 = With two-speed PTO shaft
- B 213 = With PTO shaft
- B 214 = Millimeter
- B 215 = Middle
- B 216 = On engine end
- B 217 = Middle, left
- B 218 = Middle, right
- B 219 = With blinker lamp, without fuel level gauge
- B 220 = With angle plate
- B 221 = With spigot
- B 222 = With groove
- B 223 = With blinker lamp
- B 224 = As required
- B 225 = Cancel after using up
- B 226 = Standard
- B 227 = Standard wheel
- B 228 = Only for semi-mounted plough
- B 229 = Only for perm. dimmer light
- B 230 = Only for head light flasher
- B 231 = Only for plantation tractor
- B 232 = Only available with item .....
- B 233 = Use only with item .....
- B 234 = Only for standard clutch
- B 235 = Only for dual clutch
- B 236 = Only in case of short guide rail

B 242 = At top  
B 243 = At top, LH  
B 244 = At top, RH  
B 245 = Upper part  
B 246 = Or item .....  
B 247 = w/o item .....  
B 248 = w/o cabin  
B 249 = w/o mowing attachment  
B 250 = Without blinker lamp, without tank level gauge  
B 251 = Without blinker lamp  
B 252 = Top part - for cab  
B 253 = Without headlamp, exhaust normal  
B 254 = Without headlamp, exhaust upwards  
B 255 = Without headlamp, exhaust normal, intake above  
B 256 = Without headlamp, exhaust and intake above  
B 257 = Plantation tractor  
B 258 = Item .....  
B 265 = Wheelbase  
B 266 = Right hall  
B 267 = RH  
B 268 = RH, cpl.  
B 269 = Repair set  
B 270 = Reverse  
B 271 = Reverse gear  
B 272 = Round  
B 273 = Round, diameter  
B 281 = Collective package  
B 282 = Set  
B 283 = Self-locking  
B 284 = See illustration  
B 285 = See item  
B 286 = See chart No.  
B 287 = See description  
B 288 = Tractor  
B 289 = Narrow gauge  
B 290 = High-speed  
B 291 = High-speed gear  
B 292 = Heavy  
B 293 = Tail/stop/blinker/number plate lights

- B 294 = Tail/stop/blinker lights
- B 295 = Tail/stop/number plate lights
- B 296 = Tail/stop lights
- B 297 = Synchronous
- B 298 = Spanish
- B 299 = Adjustable-gauge wheel
- B 300 = Headlamp, right.
- B 301 = Headlamp, left
- B 302 = Headlamp, top
- B 303 = Tubeless
- B 310 = Chart No.
- B 311 = Part
- B 312 = Part No.
- B 313 = Part number list sheet
- B 314 = Telescopic, unsprung
- B 321 = Oversize see item .....
- B 322 = Rev. per min.
- B 323 = Independent
- B 324 = At bottom
- B 325 = At bottom, LH
- B 326 = At bottom, RH
- B 327 = Undersize see item .....
- B 328 = Unsprung
- B 335 = Version
- B 336 = Use with item .....
- B 337 = Complete
- B 338 = Complete, LH
- B 339 = Complete, RH
- B 340 = Complete, at top
- B 341 = Complete, at bottom
- B 342 = Complete, rear
- B 343 = Complete, front
- B 344 = Fully synchronized
- B 345 = Fully synchronized with two-speed PTO shaft
- B 346 = Front
- B 347 = Complete with item .....
- B 348 = Front, left
- B 349 = Front, right

- B 355 = Item ..... at option
- B 356 = Westinghouse
- B 365 = No. of teeth
- B 366 = Together with item .....
- B 367 = To item .....
- B 380 = With front drive
- B 381 = With tube
- B 382 = Mesh-width
- B 383 = Without front drive

## O b s e r v a t i o n s

=====

- B 001 = A partir de l'essieu n°
- B 002 = A partir de l'essieu n° ..... poste
- B 003 = A partir du chassis n°
- B 004 = A partir du chassis n° ..... poste
- B 005 = A partir de la boite de vitesses n°
- B 006 = A partir de la boite de vitesses n° poste
- B 007 = A partir du moteur n°
- B 008 = A partir du moteur n° voir planche
- B 009 = Exécution toutes roues motrices
- B 010 = Ampères
- B 011 = Exécution
- B 012 = Echappement vers le haut
- B 013 = Extérieur (e) (s) (es)
- B 014 = Diamètre extérieur
- B 015 = Ancien poste n°
- B 025 = Jusqu'à l'essieu n°
- B 026 = Jusqu'à l'essieu n° poste
- B 027 = Jusqu'au chassis n°
- B 028 = Jusqu'au chassis n° poste
- B 029 = Jusqu'à la boite de vitesses n°
- B 030 = Jusqu'à la boite de vitesses n° poste
- B 031 = Jusqu'au moteur n°
- B 032 = Jusqu'au moteur n°
- B 033 = En cas d'exécution avec clignotant
- B 034 = En cas d'exécution avec prise de force à 2 régimes
- B 035 = En cas d'exécution avec barre d'attelage courte
- B 036 = En cas d'exécution avec embrayage pour prise de force indépendante
- B 037 = En cas d'exécution avec embrayage pour prise de force autonome
- B 038 = En cas d'exécution avec indication du niveau du réservoir
- B 039 = En cas d'exécution avec de force proportionnelle
- B 040 = Sur bras inf. rétractible sans trois points, sans barre oscillante
- B 041 = Lors du premier remplacement fournir également poste .....
- B 042 = Lors du premier remplacement fournir également poste ..... jusqu'au chassis n° .....

- B 043 = Pour direction hydro-assistée
- B 044 = Pour direction hydrostatique
- B 045 = Pour phare en haut
- B 046 = Pour phare à l'extérieur
- B 047 = Pour exécution avec rep. ....
- B 048 = Pour exécution sans rep. ....
- B 049 = Pour type ....., seulement pour exécution avec différentiel
- B 050 = Comprenant rep. ....
- B 060 = Version Canada
- B 061 = Représentation
- B 062 = Allemand
- B 063 = Diamètre
- B 064 = Double
- B 070 = Simple
- B 071 = Anglais
- B 072 = Pièce de rechange n°
- B 073 = Utiliser d'abord le stock
- B 074 = Remplacement pour rep. ....
- B 075 = Remplacé par rep. ....
- B 076 = Pièces détachées voir rep. ....
- B 080 = Français
- B 081 = Pour aspiration par le haut
- B 082 = Pour échappement et phares standard
- B 083 = Pour échappement vers le haut et phares standard
- B 084 = Pour exécution avec 1 distributeur intermédiaire KHD et un distributeur bridé Westinghouse
- B 085 = Pour exécution avec 2 distributeurs intermédiaires et 1 distributeur terminal KHD
- B 086 = Pour exécution avec 1 distributeur intermédiaire KHD, 1 plaque d'adaptation, 1 distributeur intermédiaire Westinghouse et 1 distributeur bridé Westinghouse
- B 087 = Pour exécution avec 2 distributeurs intermédiaires KHD, 1 plaque d'adaptation et 1 distributeur bridé Westinghouse
- B 088 = Pour exécution avec 2 distributeurs intermédiaires KHD et une plaque d'extrémité ou 1 distributeur intermédiaire KHD et 1 plaque d'extrémité
- B 089 = Pour exécution avec 1 distributeur terminal KHD ou 1 distributeur intermédiaire KHD et 1 plaque d'extrémité
- B 090 = Pour exécution avec 1 plaque d'adaptation et 1 distributeur bridé Westinghouse



- B 091 = Pour exécution avec 1 plaque d'adaptation, 1 distributeur intermédiaire Westinghouse et 1 distributeur bride Westinghouse
- B 092 = Pour exécution avec bloc de relevage
- B 093 = Pour exécution sans bloc de relevage
- B 094 = Pour pneumatiques
- B 095 = Pour ampoule phare-code
- B 096 = Pour pédale de frein
- B 097 = Pour filtre double
- B 098 = Pour double accouplement
- B 099 = Pour alternateur
- B 100 = Pour accouplement trois points
- B 101 = Pour blocage de différentiel
- B 102 = Pour filtre simple
- B 103 = Pour pédale d'accélération
- B 104 = Pour couvercle de carter
- B 105 = Pour dynamo
- B 106 = Direction hydro-assistée
- B 107 = Pour cabine
- B 108 = Pour accouplement
- B 109 = Pour exécution avec vitesse ultra-lente
- B 110 = Pour capot moteur sans phares
- B 111 = Pour essuie-glace
- B 112 = Pour phares
- B 113 = Pour exécution synchrone
- B 114 = Pour prise de force
- B 115 = Pour barre oscillante
- B 116 = Pour controle de charge
- B 117 = Pour controle de pression d'huile
- B 118 = Pour controle de filtre
- B 119 = Pour controle lumière route
- B 120 = Indication de température
- B 121 = Pour soufflante
- B 122 = Pour clignoteur de remorque
- B 123 = Pour clignoteur de tracteur
- B 124 = Pour phare extérieur
- B 125 = Pour trou oblong
- B 126 = Pour exécution avec 1 distributeur intermédiaire KHD et 1 plaque d'adaptation

- B 127 = No. de chassis comme pour rep. ....
- B 128 = Pour renvoi
- B 129 = Pour essieu télescopique
- B 130 = Pour essieu normal
- B 131 = Pour échappement et phares normaux, aspiration à l'avant
- B 132 = Pour échappement et aspiration en haut, phares normaux
- B 133 = Pour prise de force normale
- B 134 = Pour prise de force proportionnelle
- B 135 = Pour prise de courant de remorque
- B 136 = Pour phare de travail
- B 137 = Pour plaque d'immatriculation
- B 138 = Pour direction mécanique et hydro-assistée
- B 139 = Pour Epurateur d'air du type sec
- B 140 = Pour Epurateur d'air à bain d'huile
- B 141 = Vitesse
- B 142 = Coté boîte de vitesses
- B 143 = Grand (e)
- B 144 = Groupe
- B 145 = Jaune
- B 150 = Arrière
- B 151 = Arrière gauche
- B 152 = Arrière droit (e)
- B 153 = Hollandaes
- B 154 = Actionnement hydraulique
- B 161 = à l'intérieur / intérieur
- B 162 = Diamètre intérieur
- B 163 = Italien
- B 171 = Catégorie
- B 172 = Kilogrammes
- B 173 = Aile arrière
- B 174 = Aile arrière gauche
- B 175 = Aile arrière droite
- B 176 = Aile avant
- B 177 = Aile avant gauche
- B 178 = Aile avant droite
- B 179 = Vitesse ultra-lente
- B 180 = Centimètres cube  $\text{cm}^3$
- B 181 = Décimètres cube  $\text{dm}^3$
- B 182 = Court(e) (s)
- B 190 = Long(ue) (s)
- B 191 = Lent(e)
- B 192 = Léger (légère) (s)

- B 193 = Etendue de fourniture
- B 194 = Moitié gauche
- B 195 = Gauche
- B 196 = Filet gauche
- B 197 = Gauche, compl.
- B 198 = A gauche et à droite
- B 199 = Litre
- B 204 = au mètre
- B 205 = Avec plaque d'adaptation
- B 206 = Avec distributeur bridé
- B 207 = Avec prise de courant remorque
- B 208 = Avec blocage de démarrage
- B 209 = Avec phares extérieurs
- B 210 = Avec manivelle
- B 211 = Avec poste .....
- B 212 = Avec prise de force à deux régimes
- B 213 = Avec prise de force
- B 214 = Millimètres
- B 215 = Milieu / centre
- B 216 = Coté moteur
- B 217 = Centre gauche
- B 218 = Centre droit
- B 219 = Avec clignoteur, sans indicateur de niveau de réservoir
- B 220 = Avec équerre
- B 221 = Avec tenon
- B 222 = Avec rainure
- B 223 = Avec clignoteur
- B 224 = Selon besoins
- B 225 = Supprimer après épuisement des stocks
- B 226 = Standard / normal
- B 227 = Roue standard
- B 228 = Seulement pour charrue semi-portée
- B 229 = Seulement pour code permanent
- B 230 = Seulement pour avertisseur lumineux
- B 231 = Seulement pour tracteur à voie étroite
- B 232 = Seulement livrable avec poste .....
- B 233 = A utiliser seulement avec poste .....

- B 234 = Seulement pour accouplement à simple effet
- B 235 = Seulement pour accouplement à double effet
- B 236 = Seulement pour barre de guidage courte
- B 242 = En haut / supérieur
- B 243 = En haut et à gauche / supérieur gauche
- B 244 = En haut et à droite / supérieur droit(e)
- B 245 = Partie supérieure
- B 246 = ou poste .....
- B 247 = sans poste .....
- B 248 = sans cabine
- B 249 = sans barre faucheuse
- B 250 = Sans clignoteur, sans indicateur de niveau du réservoir
- B 251 = Sans clignoteur
- B 252 = Partie supérieure - pour cabine
- B 253 = Sans phare, échappement normal
- B 254 = Sans phare, échappement vers le haut
- B 255 = Sans phare, échappement normal, aspiration en haut
- B 256 = Sans phare, échappement et aspiration en haut
- B 257 = Tracteur à voie étroite
- B 258 = Poste .....
- B 265 = Empattement
- B 266 = Moitié droite
- B 267 = Droite(e) / à droite
- B 268 = Droite(e) compl.
- B 269 = Lot réparation
- B 270 = Arrière
- B 271 = Vitesse arrière
- B 272 = Rond
- B 273 = Rond, diamètre  $\emptyset$
- B 281 = Emballage collectif
- B 282 = Jeu
- B 283 = Auto-freinant
- B 284 = Voir figure
- B 285 = Voir poste
- B 286 = Voir planche n<sup>o</sup>
- B 287 = Voir explications
- B 288 = Tracteur
- B 289 = Voie étroite

- B 290 = Rapide
- B 291 = Vitesse rapide
- B 292 = Lourd(e)
- B 293 = Feu combiné AR-stop-clignotant-de plaque d'immatriculation
- B 294 = Feu combiné AR-stop-clignotant
- B 295 = Feu combiné AR-stop-de plaque d'immatriculation
- B 296 = Feu combiné AR-stop
- B 297 = Synchrone
- B 298 = Espagnol
- B 299 = Roue à réglage de voie
- B 300 = Phare - droit.
- B 301 = Phare - gauche
- B 302 = Phare - en haut
- B 303 = Sans chambre à air
- B 310 = Planche n°
- B 311 = Pièce
- B 312 = Pièce n°
- B 313 = Feuille de liste de numéros de pièce
- B 314 = Télescopique - sans suspension
- B 321 = Cote surdimensionnée voir poste .....
- B 322 = Tours/minute
- B 323 = Indépendant
- B 324 = en bas / inférieur
- B 325 = Inférieur gauche
- B 326 = Inférieur droit(e)
- B 327 = Cote sousdimensionnée voir poste .....
- B 328 = Sans suspension
- B 335 = Variante
- B 336 = Utiliser avec poste .....
- B 337 = Compl.
- B 338 = Compl., gauche
- B 339 = Compl., droit(e)
- B 340 = Compl., supérieur(e)
- B 341 = Compl., inférieur(e)
- B 342 = Compl., arrière
- B 343 = Compl., avant
- B 344 = Entièrement synchronisé
- B 345 = Entièrement synchronisé avec prise de force à 2 régimes

- B 346 = Avant
- B 347 = Compl. avec rep. ....
- B 348 = Avant - à gauche
- B 349 = Avant - à droite
- B 355 = Au choix poste .....
- B 356 = Westinghouse
- B 365 = Nombre de dents
- B 366 = Ensemble avec poste .....
- B 367 = Pour poste .....
- B 380 = A traction avant
- B 381 = Avec tuyau
- B 382 = Ouverture de maille
- B 383 = Sans essieu avant moteur

O b s e r v a c i o n e s

=====

- B 001 = A partir eje No.
- B 002 = A partir eje No. Pos.
- B 003 = A partir chasis No.
- B 004 = A partir chasis No. Pos.
- B 005 = A partir transmisión No.
- B 006 = A partir transmisión No. Pos.
- B 007 = A partir motor No.
- B 008 = A partir motor No. véase grabado
- B 009 = Versión de tracción universal
- B 010 = Amperios
- B 011 = Ejecución
- B 012 = Escape hacia arriba
- B 013 = Exterior
- B 014 = Diámetro exterior
- B 015 = Antiguo No. de Pos.
- B 025 = Hasta eje No.
- B 026 = Hasta eje No. Pos.
- B 027 = Hasta chasis No.
- B 028 = Hasta chasis No. Pos.
- B 029 = Hasta transmisión No.
- B 030 = Hasta transmisión No. Pos.
- B 031 = Hasta motor No.
- B 032 = Hasta motor No. véase grabado
- B 033 = En la versión con intermitentes
- B 034 = En la versión con toma de fuerza "Duo"
- B 035 = En la versión con carril de guía corto
- B 036 = En la versión con embrague doble dependiente del motor
- B 037 = En la versión con embrague doble independiente
- B 038 = En la versión con indicador de nivel del tanque
- B 039 = En la versión con toma de fuerza dependiente del avance
- B 040 = Existiendo guías telescópicas, sin acoplamiento en tres puntos, sino péndulo de tracción
- B 041 = En el primer suministro de repuestos acompañar Pos. ....
- B 042 = En el primer suministro de repuestos hasta chasis No. ....  
acompañar Pos. ....
- B 043 = Existiendo servo-dirección hidráulica
- B 044 = Existiendo dirección hidrostática

- B 045 = Existiendo faros superiores
- B 046 = Existiendo faros exteriores
- B 047 = En la ejecución con Pos. ....
- B 048 = En la ejecución sin Pos. ....
- B 049 = En tipo ..... sólo para ejecución con diferencial
- B 050 = Consistiendo en Pos. ....
- B 060 = Versión "Canada"
- B 061 = Representación
- B 062 = Alemán
- B 063 = Diámetro
- B 064 = Doble
- B 070 = Simple
- B 071 = Inglés
- B 072 = Lista de repuestos No.
- B 073 = Agotar primero existencias en almacén
- B 074 = Sustituye a Pos. ....
- B 075 = Sustitución por Pos. ....
- B 076 = Partes individuales véase Pos. ....
- B 080 = Francés
- B 081 = Para aspiración desde arriba
- B 082 = Para escape y faros versión normal
- B 083 = Para escape hacia arriba y faros versión normal
- B 084 = Para versión con un aparato de mando intermedio KHD y un aparato de mando abridado Westinghouse
- B 085 = Para versión con dos aparatos de mando intermedio y un aparato de mando final KHD
- B 086 = Para versión con un aparato de mando intermedio KHD, una placa de adaptación, un aparato de mando intermedio Westinghouse y un aparato de mando abridado Westinghouse
- B 087 = Para versión con dos aparatos de mando intermedios KHD, una placa de adaptación y un aparato de mando abridado Westinghouse
- B 088 = Para versión con dos aparatos de mando intermedios KHD y una placa final, o un aparato de mando intermedio KHD y una placa final
- B 089 = Para versión con un aparato de mando final KHD o un aparato de mando intermedio KHD y una placa final
- B 090 = Para versión con una placa de adaptación y un aparato de mando abridado Westinghouse
- B 091 = Para versión con una placa de adaptación, un aparato de mando intermedio Westinghouse y un aparato de mando abridado Westinghouse



- B 092 = Para versión con elevador hidráulico
- B 093 = Para versión sin elevador hidráulico
- B 094 = Para neumáticos
- B 095 = Para lámpara Bilux
- B 096 = Para pedal de freno
- B 097 = Para filtro doble
- B 098 = Para embrague doble
- B 099 = Para generatriz de corriente trifásica
- B 100 = Para acoplamiento en tres puntos
- B 101 = Para bloqueo de diferencial
- B 102 = Para filtro simple
- B 103 = Para pedal acelerador
- B 104 = Para tapa de caja
- B 105 = Para generatriz de corriente continua
- B 106 = Servo-dirección hidráulica
- B 107 = Para cabina
- B 108 = Para embrague
- B 109 = Para versión con marchas ultralentas
- B 110 = Para capot de motor sin faros incorporados
- B 111 = Para limpia-parabrisas
- B 112 = Para faros
- B 113 = Para versión sincronizada
- B 114 = Para árbol toma de fuerza
- B 115 = Para péndulo de tracción
- B 116 = Para control de carga
- B 117 = Para control de presión de aceite
- B 118 = Para control de filtro
- B 119 = Para control para luz de carretera
- B 120 = Indicador de temperatura
- B 121 = Para ventilador
- B 122 = Para luces intermitentes para remolques
- B 123 = Para luces intermitentes para tractor
- B 124 = Para faros exteriores
- B 125 = Para orificio alargado
- B 126 = Para ejecución con 1 aparato de mando intermedio KHD y  
1 placa intermedia
- B 127 = Chasis No. como Pos. ....
- B 128 = Para transmisión
- B 129 = Para eje telescópico

- B 130 = Para eje normal
- B 131 = Para escape y faros normales, admisión delante
- B 132 = Para escape y admisión arriba, faros normales
- B 133 = Para árbol toma de fuerza dependiente del embrague
- B 134 = Para árbol toma de fuerza dependiente de la rodadura
- B 135 = Para caja de enchufe para remolque
- B 136 = Para faros de trabajo
- B 137 = Para matrícula
- B 138 = Para dirección mecánica y servodirección hidráulica
- B 139 = Para Filtro de aire en seco
- B 140 = Para Filtro de aire en baño de aceite
- B 141 = Marcha
- B 142 = Lado del cambio
- B 143 = Grande
- B 144 = Grupo
- B 145 = Amarillo
- B 150 = Atrás
- B 151 = Atrás-izquierda
- B 152 = Atrás-derecha
- B 153 = Holandés
- B 154 = Accionamiento hidráulico
- B 161 = Interior
- B 162 = Diámetro interior
- B 163 = Italiano
- B 171 = Categoría
- B 172 = Kilogramos
- B 173 = Guardabarros-atrás
- B 174 = Guardabarros-atrás-izquierda
- B 175 = Guardabarros-atrás-derecha
- B 176 = Guardabarros-delante
- B 177 = Guardabarros-delante-izquierda
- B 178 = Guardabarros-delante-derecha
- B 179 = Marcha ultralenta
- B 180 = Centímetros cúbicos (cm<sup>3</sup>)
- B 181 = Decímetros cúbicos (dm<sup>3</sup>)
- B 182 = Corto
- B 190 = Largo
- B 191 = Lento
- B 192 = Liviano
- B 193 = Volumen de suministro

- B 194 = Mitad izquierda
- B 195 = Izquierda
- B 196 = Rosca paso a izquierda
- B 197 = Izquierda, compl.
- B 198 = Izquierda y derecha
- B 199 = Litros
- B 204 = Por metros
- B 205 = Con placa de adaptación
- B 206 = Con aparato de mando abridado
- B 207 = Con caja de enchufe para remolque
- B 208 = Con bloqueo contra arranque
- B 209 = Con faros exteriores
- B 210 = Con manivela
- B 211 = Con Pos. ....
- B 212 = Con toma de fuerza "Duo"
- B 213 = Con árbol toma de fuerza
- B 214 = Milímetros
- B 215 = Centrol
- B 216 = Lado motor
- B 217 = Centro - izquierda
- B 218 = Centro - derecha
- B 219 = Con interm entes, sin indicador para contenido del tanq'
- B 220 = Con ángul.
- B 221 = Con munón
- B 222 = Con ranura
- B 223 = Con intermitentes
- B 224 = Según necesidad
- B 225 = Tachar después de consumirse
- B 226 = Normal
- B 227 = Rueda normal
- B 228 = Sólo para arado con tercer punto móvil
- B 229 = Sólo para constante luz de cruce
- B 230 = Sólo para bocina luminosa
- B 231 = Sólo para tractor de cultivo
- B 232 = Sólo suministrable con Pos. ....
- B 233 = Sólo utilizable con Pos. ....
- B 234 = Sólo existiendo embrague simple

- B 235 = Sólo existiendo embrague doble
- B 236 = Sólo al existir corta barra de guía
- B 242 = Arriba
- B 243 = Arriba-izquierda
- B 244 = Arriba-derecha
- B 245 = Parte superior
- B 246 = O Pos. ....
- B 247 = Sin Pos. ....
- B 248 = Sin cabina
- B 249 = Sin segadora
- B 250 = Sin intermitentes, sin indicador para contenido del tanque
- B 251 = Sin intermitentes
- B 252 = Parte superior - cabina
- B 253 = Sin faros, escape normal
- B 254 = Sin faros, escape hacia arriba
- B 255 = Sin faros, escape normal admisión desde arriba
- B 256 = Sin faros, escape y admisión arriba
- B 257 = Tractor de cultivo
- B 258 = Pos. ....
- B 265 = Distancia entre ejes
- B 266 = Mitad derecha
- B 267 = Derecha
- B 268 = Derecha, compl.
- B 269 = Lote de reparación
- B 270 = Atrás
- B 271 = Marcha atrás
- B 272 = Redondo
- B 273 = Redondo, diámetro ( $\emptyset$ )
- B 281 = Paquete colectivo
- B 282 = Lote
- B 283 = Autoafianzador
- B 284 = Véase Fig.
- B 285 = Véase Pos.
- B 286 = Véase grabado No.
- B 287 = Véase aclaración
- B 288 = Tractor

- B 289 = Via estrecha
- B 290 = Rápido
- B 291 = Marcha rápida
- B 292 = Pesado
- B 293 = Luz piloto con luz de frenado, intermitente y alumbrado de matricula
- B 294 = Luz piloto con luz de alumbrado e intermitente
- B 295 = Luz piloto con luz de frenado y alumbrado de matricula
- B 296 = Luz piloto con luz de frenado
- B 297 = Sincronizado
- B 298 = Espanol
- B 299 = Rueda de modificación de ancho de rodada
- B 300 = Faro - derecha
- B 301 = Faro - izquierda
- B 302 = Faros - superiores
- B 303 = Sin cámara
- B 310 = Grabado No.
- B 311 = Pieza
- B 312 = Pieza No.
- B 313 = Hoja de lista de Nos. de piezas
- B 314 = Telescópico - sin suspensión elástica
- B 321 = Medida de desgaste véase Pos. ....
- B 322 = Revoluciones por minuto
- B 323 = Independiente
- B 324 = Abajo
- B 325 = Abajo-izquierda
- B 326 = Abajo-derecha
- B 327 = Medida de desgaste véase Pos. ....
- B 328 = Sin suspensión elástica
- B 335 = Variante
- B 336 = Utilizar con Pos. ....
- B 337 = Completo
- B 338 = Completo, izquierda
- B 339 = Completo, derecha
- B 340 = Completo, arriba
- B 341 = Completo, abajo
- B 342 = Completo, atrás
- B 343 = Completo, delante

- B 344 = Con sincronización total
- B 345 = Con sincronización total, con toma de fuerza "Duo"
- B 346 = Delante
- B 347 = Compl. con Pos.
- B 348 = Delante - izquierda
- B 349 = Delante - derecha
- B 355 = Opcionalmente Pos. ....
- B 356 = Westinghouse
- B 365 = No. de dientes
- B 366 = Junto con Pos. ....
- B 367 = Para Pos. ....
- B 380 = Con propulsión delantera
- B 381 = Con tubo
- B 382 = Luz de malla
- B 383 = Sin propulsión delantera

Klöckner-Humboldt-Deutz AG

